

Product Specification

Specifications ■

Description In-Line Vacuum Breaker, Type "W"
 Material Brass
 Finish Chrome plated
 Certified CSA B125
 Shipping Weight 1.0 lb. (0.50 kg.)



Dimensions ■

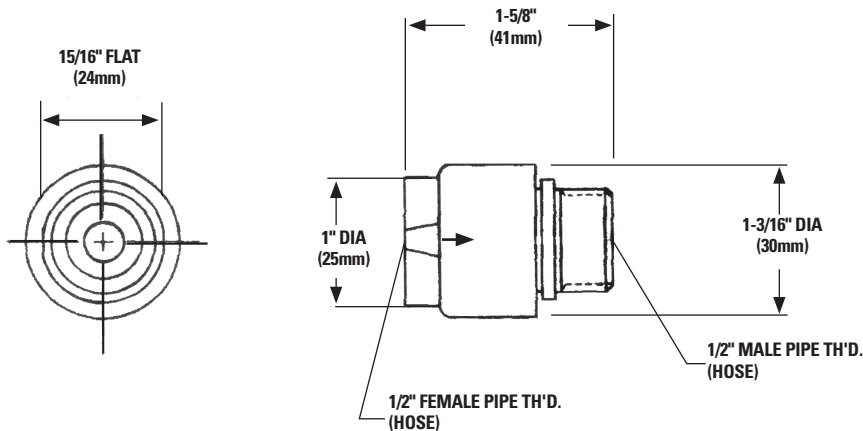

ENGINEERING APPROVAL	
Project:	_____
Contractor:	_____
Architect/Engineer:	_____

