

13 SEER, 7.7 HSPF, PACKAGE HEAT PUMP, 2 to 5 TONS

Single Phase, 208/230 V, 60 Hz

REFRIGERATION CIRCUIT

- Environmentally sound R-410A refrigerant
- Copper tube/aluminum fin condenser and evaporator coils
- Scroll compressor standard on all models
- Short-cycling protection for the compressor is built into the defrost control board
- Dehumidification mode (airflow reduction) on all models

EASY TO INSTALL AND SERVICE

- Installs easily on a rooftop or at ground level
- Easy three-panel accessibility for maintenance and installation
- Easily converts to down discharge applications
- Combination electric heating and cooling

BUILT TO LAST

- High efficiency ECM indoor blower motor on all models
- Pre-painted steel cabinet
- Vertical condenser fan discharge
- Hail guard (3/8" spacing) wire grilles standard on PHD3**000KTP models (2" spacing wire grilles on non-tin models)
- Full perimeter steel base rails
- High and low pressure switches provide added reliability for the compressor
- All models available with optional factory installed tin-coated copper evaporator coil (These models are identified with letters TP in the 11th and 12th positions in the model number)

WARRANTY*

- 1 year No Hassle Replacement limited warranty for models with tin coated copper evaporator coils
- 5 year parts limited warranty (including compressor and coils)
 - With timely registration, an additional 5 year parts limited warranty (including compressor and coils)

*Applies to original purchaser/homeowner, some limitations may apply. See warranty certificate for complete details.



Use of the AHRI Certified TM Mark indicates a manufacturer's participation in the program. For verification of certification for individual products, go to www.ahridirectory.org.

UNIT PERFORMANCE DATA							
Model Number	COOLING			HEATING		Unit Dimensions Height x Width x Depth in (mm)	Operating Weight lbs (kg)
	Capacity BTU/h	SEER	EER	Capacity BTU/h	HSPF		
PHD324000K000C	23,800	13.5	11.5	23,400	7.7	42x48 ³ / ₁₆ x32 ⁵ / ₈ (1065x1224x829)	320 (145)
PHD324000KTP0C	23,800	13.5	11.5	23,400	7.7	42x48 ³ / ₁₆ x32 ⁵ / ₈ (1065x1224x829)	320 (145)
PHD330000K000C	29,000	13.5	11.5	29,000	7.7	42x48 ³ / ₁₆ x32 ⁵ / ₈ (1065x1224x829)	332 (150)
PHD330000KTP0C	29,000	13.5	11.5	29,000	7.7	42x48 ³ / ₁₆ x32 ⁵ / ₈ (1065x1224x829)	332 (150)
PHD336000K000C	35,000	13.5	11.5	35,000	7.7	42x48 ³ / ₁₆ x32 ⁵ / ₈ (1116x1224x829)	336 (152)
PHD336000KTP0C	35,000	13.5	11.5	35,000	7.7	42x48 ³ / ₁₆ x32 ⁵ / ₈ (1116x1224x829)	336 (152)
PHD342000K000C	40,000	13.2	11.5	40,000	7.7	45 ⁷ / ₈ x48 ³ / ₁₆ x44 ¹ / ₈ (1165x1224x1123)	441 (186)
PHD342000KTP0C	40,000	13.2	11.5	40,000	7.7	45 ⁷ / ₈ x48 ³ / ₁₆ x44 ¹ / ₈ (1165x1224x1123)	441 (186)
PHD348000K000C	47,000	13.5	11.5	46,500	7.7	45 ⁷ / ₈ x48 ³ / ₁₆ x44 ¹ / ₈ (1165x1224x1123)	429 (194)
PHD348000KTP0C	47,000	13.5	11.5	46,500	7.7	45 ⁷ / ₈ x48 ³ / ₁₆ x44 ¹ / ₈ (1165x1224x1123)	429 (194)
PHD360000K000C	57,000	13.5	11.5	57,000	7.7	49 ⁷ / ₈ x48 ³ / ₁₆ x44 ¹ / ₈ (1265x1224x1123)	454 (206)
PHD360000KTP0C	57,000	13.5	11.5	57,000	7.7	49 ⁷ / ₈ x48 ³ / ₁₆ x44 ¹ / ₈ (1265x1224x1123)	454 (206)

MODEL NOMENCLATURE											
MODEL SERIES	1	2	3	4	5,6	7,8,9	10	11,12	13	14	15
	P	H	D	3	36	000	K	00	0	C	1
P = Package		TYPE		TIER		SEER					
H = Heat Pump											
D = Standard											
3 = 13											
4 = 14											
5 = 15											
24 = 24,000 BTUH = 2 Tons											
30 = 30,000 BTUH = 2.5 Tons											
36 = 36,000 BTUH = 3 Tons											
42 = 42,000 BTUH = 3.5 Tons											
48 = 48,000 BTUH = 4 Tons											
60 = 60,000 BTUH = 5 Tons											
								NOMINAL COOLING CAPACITY			
000 = no factory heat								NOMINAL HEATING BTUH (input)			
K = 208/230-1-60								VOLTAGE			
00 = No options								FACTORY INSTALLED OPTIONS			
TP = Tin Plated Evaporator Main Tubes											
0 = Standard								FEATURE CODE			
Sales Model Digit											
Engineering Digit											

AHRI* CAPACITIES

COOLING CAPACITIES AND EFFICIENCIES					
UNIT PHD3	NOMINAL TONS	STANDARD CFM	COOLING CAPACITIES (Btuh)	EER**	SEER†
24	2	800	23,800	11.5	13.5
30	2-1/2	1000	29,000	11.5	13.5
36	3	1200	35,000	11.5	13.5
42	3-1/2	1400	40,000	11.5	13.2
48	4	1600	47,000	11.5	13.5
60	5	1850	57,000	11.5	13.5

HEAT PUMP HEATING CAPACITIES AND EFFICIENCIES					
UNIT PHD3	HEATING CAPACITY (Btuh) @ 47°F (8.3°C)	COP @ 47°F (8.3°C)	HEATING CAPACITY (Btuh) @ 17°F (-8.3°C)	COP @ 17°F (-8.3°C)	HSPF†
24	23,400	3.5	10,800	2.2	7.7
30	29,000	3.5	15,900	2.2	7.7
36	35,000	3.4	20,400	2.3	7.7
42	40,000	3.4	22,000	2.2	7.7
48	46,500	3.6	26,200	2.3	7.7
60	57,000	3.5	31,000	2.3	7.7

LEGEND

dB – Sound Levels (decibels)

db – Dry Bulb

SEER – Seasonal Energy Efficiency Ratio

wb – Wet Bulb

COP – Coefficient of Performance

HSPF – Heating Season Performance Factor

* Air Conditioning, Heating, & Refrigeration Institute.

**At "A" conditions–80°F (26.7°C) indoor db/67°F (19.4°C) indoor wb & 95°F (35°C)

outdoor db.

†Rated in accordance with U.S. Government DOE (Department of Energy) test

procedures and/or AHRI Standards 210/240.

Notes:

1. Ratings are net values, reflecting the effects of circulating fan heat.

Ratings are based on:

Cooling Standard: 80°F (26.7°C) db, 67°F (19.4°C) wb indoor entering–air temperature and 95°F (35°C) db outdoor entering–air temperature.

2. Before purchasing this appliance, read important energy cost and efficiency information available from your retailer.

ELECTRICAL DATA – PHD3

UNIT	NOMINAL V-PH-HZ	VOLTAGE RANGE		COMPRESSOR			OFM	IFM	ELECTRIC HEAT		POWER SUPPLY	
		MIN	MAX	RLA	LRA	MCC	FLA	FLA	NOMIN kW 208v/230v	FLA 208v/230v	MCA 208v/230v	MOCP 208v/230v
PHD324	208/230-1-60	197	253	13.5	58.3	20.0	1.2	4.1	-/-	-/-	22.2	30
									3.8/5	18.1/20.8	44.8/48.2	45/50
									5.4/7.2	25.9/30	54.6/59.7	60/60
									7.5/10	36.1/41.7	67.3/74.3	70/80
PHD330	208/230-1-60	197	253	16	73	22.0	1.2	4.1	-/-	-/-	25.3	40
									3.8/5	18.1/20.8	47.9/51.3	50/60
									5.4/7.2	25.9/30	57.7/62.8	60/70
									7.5/10	36.1/41.7	70.4/77.4	80/80
PHD336	208/230-1-60	197	253	19.3	79	26.0	1.2	6.0	-/-	-/-	31.3	45
									3.8/5	18.1/20.8	54/57.3	60/60
									5.4/7.2	25.9/30	63.7/68.8	70/70
									7.5/10	36.1/41.7	76.5/83.5	80/90
PHD342	208/230-1-60	197	253	20.9	112	28.0	1.2	6.0	-/-	-/-	33.3	50
									3.8/5	18.1/20.8	56/59.3	60/60
									5.4/7.2	25.9/30	65.7/70.8	70/80
									7.5/10	36.1/41.7	78.5/85.5	80/90
PHD348	208/230-1-60	197	253	23.5	117	34.0	1.2	7.6	-/-	-/-	38.2	50
									3.8/5	18.1/20.8	60.8/64.2	70/70
									5.4/7.2	25.9/30	70.6/75.7	80/80
									7.5/10	36.1/41.7	83.3/90.3	90/100
PHD360	208/230-1-60	197	253	27.4	134	41.2	1.2	7.6	-/-	-/-	43.1	60
									3.8/5	18.1/20.8	65.7/69.1	70/70
									5.4/7.2	25.9/30	75.4/80.6	80/90
									7.5/10	36.1/41.7	88.2/95.2	90/100
									11.3/15	54.2/62.5	110.8/121.2	125/125
									15/20	72.2/83.3	133.3/147.2	150/150

LEGEND

- FLA = Full Load Amps
- LRA = Locked Rotor Amps
- MCA = Minimum Circuit Ampacity
- MOCP = Maximum Overcurrent Protection
- RLA = Rated Load Amps



1. In compliance with NEC (National Electrical Code) requirements for multimotor and combination load equipment (refer to NEC Articles 430 and 440), the overcurrent protective device for the unit shall be Power Supply fuse. The CGA (Canadian Gas Association) units may be fuse or circuit breaker.
2. Minimum wire size is based on 60 C copper wire. If other than 60 C wire is used, or if length exceeds wire length in table, determine size from NEC.

PHYSICAL DATA – UNIT PHD3							
UNIT SIZE		24	30	36	42	48	60
NOMINAL CAPACITY (ton)		2	2.5	3	3.5	4	5
SHIPPING WEIGHT (lb)		327	340	343	419	437	462
(kg)		148	154	156	190	198	210
COMPRESSOR QUANTITY		1					
TYPE		SCROLL COMPRESSOR					
REFRIGERANT		R-410A					
Quantity (lb)		9.6	10.2	7.9	10.0	9.6	12.3
Quantity (kg)		4.4	4.6	3.6	4.5	4.4	5.6
METERING DEVICE ID		TXV					
ORIFICE OD	(in.) (mm)	0.032 (2)	0.035 (2)	0.037 (2)	0.038 (Left OD Coil)	0.046 (2)	0.052 (2)
		.81	.89	.94	0.040 (Right OD Coil)	1.2	1.3
OUTDOOR COIL	Rows... Fins/in.	2...21	2...21	2...21	2...21	2...21	2...21
	face area (sq. ft.)	11.9	11.9	11.9	13.6	13.6	17.5
OUTDOOR FAN	Nominal Airflow (CFM)	2700	2700	2700	3100	3100	3100
	Fan Diameter (in.)	24	24	24	26	26	26
	Fan Diameter (mm)	610	610	610	660	660	660
	Diameter Motor HP (RPM)	1/5 (810)	1/5 (810)	1/5 (810)	1/5 (810)	1/5 (810)	1/5 (810)
INDOOR COIL	Rows... Fins/in.	3...17	3...17	3...17	3...17	3...17	3...17
	face area (sq. ft.)	3.7	3.7	3.7	4.7	4.7	5.7
INDOOR BLOWER	Nominal Cooling Airflow (CFM)	800	1000	1200	1400	1600	1850
	Size (in.)	10x10	10x10	11x10	11x10	11x10	11x10
	(mm)	254x254	254x254	279x254	279x254	279x254	279x254
	Motor (HP)	1/2	1/2	3/4	3/4	1.0	1.0
HIGH-PRESSURE SWITCH (psig)	Cutout	650±15					
	Reset (Auto)	420±25					
LOSS-OF-CHARGE/ LOW-PRESSURE SWITCH	(Liquid Line) (psig)	20±5					
	Cutout	45±10					
RETURN-AIR FILTERS*†	throwaway (in.)	20x20x1	20x24x1	24x30x1		24x36x1	
	(mm)	508x508x25	508x610x25	610x762x25		610x914x25	

*Required filter sizes shown are based on the larger of the AHRI (Air conditioning, Heating and Refrigeration Institute) rated cooling airflow or the heating airflow velocity of 300 ft/minute for throwaway type or 450 ft/minute for high-capacity type. Air filter pressure drop for non-standard filters must not exceed 0.08 in wc.

† If using accessory filter rack refer to the filter rack installation instructions for correct filter size and quantity.

DRY COIL AIR DELIVERY* – HORIZONTAL AND DOWNFLOW DISCHARGE – UNIT PHD324–60												
UNIT	MOTOR SPEED	WIRE COLOR		EXTERNAL STATIC PRESSURE (in wc)								
				0.1	0.2	0.3	0.4	0.5	0.6	0.7	0.8	0.9
PHD324	Low	Blue	CFM	754	650	538	429	---	---	---	---	---
	Med-Low	Pink	CFM	851	777	675	591	475	---	---	---	---
	Medium ¹	Red	CFM	941	851	774	684	576	479	---	---	---
	Med-High	Orange	CFM	1009	917	840	759	667	577	447	---	---
	High	Black	CFM	1241	1167	1111	1036	969	881	818	731	640
PHD330	Low	Blue	CFM	741	638	547	415	---	---	---	---	---
	Med-Low	Pink	CFM	973	887	823	733	665	538	451	---	---
	Medium	Red	CFM	1088	1023	954	881	800	723	658	563	461
	Med-High ¹	Orange	CFM	1140	1064	996	915	840	758	687	564	480
	High	Black	CFM	1202	1140	1082	1015	961	881	810	732	631
PHD336	Low	Blue	CFM	1234	1168	1093	1021	961	894	825	759	687
	Med-Low	Pink	CFM	1290	1223	1154	1090	1027	977	894	828	762
	Medium ¹	Red	CFM	1354	1290	1226	1158	1102	1046	981	918	843
	Med-High	Orange	CFM	1606	1546	1489	1430	1371	1316	1258	1208	1140
	High	Black	CFM	1630	1580	1517	1463	1407	1339	1277	1210	1131
PHD342	Low	Blue	CFM	1295	1234	1182	1126	1075	1016	955	898	857
	Med-Low	Pink	CFM	1345	1282	1235	1194	1140	1095	1027	974	921
	Medium	Red	CFM	1505	1452	1413	1358	1323	1282	1234	1169	1130
	Med-High ¹	Orange	CFM	1545	1492	1449	1411	1362	1313	1278	1231	1188
	High	Black	CFM	1705	1643	1607	1568	1518	1483	1448	1404	1360
PHD348	Low	Blue	CFM	1402	1351	1311	1263	1224	1172	1136	1080	1041
	Med-Low	Pink	CFM	1457	1404	1367	1318	1284	1233	1197	1144	1104
	Medium ¹	Red	CFM	1736	1695	1642	1601	1553	1512	1465	1427	1381
	Med-High	Orange	CFM	2149	2111	2062	2026	1980	1945	1905	1864	1793
	High	Black	CFM	2344	2306	2259	2203	2141	2070	1991	1902	1803
PHD360	Low	Blue	CFM	1445	1389	1341	1281	1236	1189	1139	1072	1027
	Med-Low	Pink	CFM	1678	1635	1602	1558	1513	1474	1438	1404	1349
	Medium ¹	Red	CFM	1927	1893	1858	1824	1791	1759	1720	1689	1640
	Med-High	Orange	CFM	2131	2088	2065	2013	1982	1941	1888	1860	1785
	High	Black	CFM	2461	2409	2339	2286	2192	2140	2062	1968	1874

* Air delivery values are without air filter and are for dry coil (See PHD3– Horizontal Wet Coil Pressure Drop Table).

¹ Factory-shipped cooling speed

NOTE: For horizontal applications deduct field-supplied air filter pressure drop and wet coil pressure drop to obtain external static pressure available for ducting. For downflow applications see Wet Coil Air Delivery Table for available static including wet coil, 1-in. (25 mm) filter and economizer.

Shaded areas indicate speed/static combinations that are not permitted for dehumidification speed.

HORIZONTAL WET COIL PRESSURE DROP (in wc)

UNIT SIZE	STANDARD CFM (S.C.F.M.)															
	500	600	700	800	900	1000	1100	1200	1300	1400	1500	1600	1700	1800	1900	2000
24		0.06	0.07	0.08	0.09	0.1										
30				0.12	0.15	0.19	0.23	0.27								
36						0.07	0.11	0.18	0.26	0.35						
42									0.04	0.07	0.1	0.15	0.21			
48											0.11	0.14	0.17	0.22	0.28	
60												0.1	0.17	0.23	0.31	0.36

DOWNFLOW WET COIL AIR DELIVERY (CFM) – HIGH SPEED WITH 1-IN. (25 MM) FILTER AND ECONOMIZER

UNIT SIZE	EXTERNAL STATIC PRESSURE (in wc)										
	0.1	0.2	0.3	0.4	0.5	0.6	0.7	0.8	0.9	1.0	
36	1333	1289	1256	1214	1152	1118	1076	1035	997	950	
42	1612	1569	1527	1481	1451	1393	1351	1317	1278	1242	
48	2166	2085	2002	1919	1798	1709	1582	1467	1270	988	
60	2298	2239	2180	2110	2044	1951	1862	1777	1697	1591	

HORIZONTAL FILTER PRESSURE DROP TABLE (in wc)

FILTER SIZE in. (mm)	CFM																		
	500	600	700	800	900	1000	1100	1200	1300	1400	1500	1600	1700	1800	1900	2000	2100	2200	2300
20X20X1 (508X508X25)	0.05	0.07	0.08	0.1	0.12	0.13	0.14	0.15	—	—	—	—	—	—	—	—	—	—	—
20X24X1 (508X610x25)	—	—	—	.09	.10	.11	.13	.14	.15	.16	—	—	—	—	—	—	—	—	—
24X30X1 (610X762x25)	—	—	—	0.04	0.05	0.06	0.07	0.07	0.08	0.09	0.1	—	—	—	—	—	—	—	—
24X36X1 (610X914X25)	—	—	—	—	—	—	—	0.06	0.07	0.07	0.08	0.09	0.09	0.10	0.11	0.12	0.13	0.14	0.14

ECONOMIZER 1-IN. FILTER PRESSURE DROP (in wc)

UNIT PHD3	PRESSURE DROP
24-36	0.20
42-60	0.25

MULTIPLICATION FACTORS

HEATER kW RATING	VOLTAGE DISTRIBUTION	MULTIPLICATION FACTOR
240	200	0.69
	208	0.75
	230	0.92
	240	1.00

ELECTRIC HEAT PRESSURE DROP TABLE (in wc) SMALL CABINET: PHD324-36 CFM

	500	600	700	800	900	1000	1100	1200	1300	1400	1500	1600
5kw	0.00	0.00	0.00	0.00	0.00	0.00	0.00	0.00	0.02	0.04	0.06	0.07
7.5 kw	0.00	0.00	0.00	0.00	0.00	0.00	0.00	0.02	0.03	0.05	0.07	0.09
10 kw	0.00	0.00	0.00	0.00	0.00	0.00	0.02	0.04	0.06	0.07	0.09	0.11
15 kw	0.00	0.00	0.00	0.02	0.04	0.06	0.08	0.10	0.12	0.14	0.16	0.18

ELECTRIC HEAT PRESSURE DROP TABLE (in wc) LARGE CABINET PHD342-060 CFM

	1100	1200	1300	1400	1500	1600	1700	1800	1900	2000	2100	2200	2300	2400	2500
5kw	0.00	0.00	0.00	0.01	0.02	0.03	0.04	0.05	0.06	0.07	0.08	0.09	0.10	0.11	0.12
7.5 kw	0.00	0.00	0.01	0.02	0.03	0.04	0.05	0.06	0.07	0.08	0.09	0.10	0.11	0.12	0.13
10 kw	0.00	0.00	0.01	0.02	0.03	0.04	0.05	0.06	0.07	0.08	0.09	0.10	0.11	0.12	0.13
15 kw	0.00	0.02	0.03	0.04	0.05	0.06	0.07	0.08	0.09	0.10	0.11	0.12	0.13	0.14	0.15
20 kw	0.02	0.03	0.04	0.05	0.06	0.07	0.08	0.09	0.10	0.11	0.12	0.13	0.14	0.15	0.16

MINIMUM AIRFLOW FOR RELIABLE ELECTRIC HEATER OPERATION (CFM)

SIZE	PHD324	PHD330	PHD336	PHD342	PHD348	PHD360
AIRFLOW (CFM)	800	1025	1250	1400	1710	1800

A-WEIGHTED SOUND POWER LEVEL (dBA)

MODEL PHD3	STANDARD RATING (dBA)	TYPICAL OCTAVE BAND SPECTRUM (dBA) (without tone adjustment)						
		125	250	500	1000	2000	4000	8000
24	76	57.0	65.5	72.0	71.0	67.0	62.0	53.0
30	76	60.5	67.5	72.0	70.0	67.0	61.0	51.5
36	77	63.0	68.0	73.0	71.0	67.0	62.0	55.0
42	78	65.0	68.5	74.5	72.5	69.5	64.5	56.5
48	78	62.0	68.5	74.0	72.5	70.0	64.0	56.0
60	76	63.0	66.5	69.5	71.0	66.0	65.0	59.0

NOTE: Tested in accordance with AHRI Standard 270 (not listed in AHRI).

PHD324 COOLING EXTENDED PERFORMANCE TABLE																			
EVAPORATOR AIR		CONDENSER ENTERING AIR TEMPERATURES °F (°C)																	
		75 (23.9)			85 (29.4)			95 (35)			105 (40.5)			115 (46.1)			125 (51.7)		
		Capacity MBtuh		Total Sys KW	Capacity MBtuh		Total Sys KW	Capacity MBtuh		Total Sys KW	Capacity MBtuh		Total Sys KW	Capacity MBtuh		Total Sys KW	Capacity MBtuh		Total Sys KW
CFM / BF	EWB °F (°C)	Total	Sens	Total	Sens	Total	Sens	Total	Sens	Total	Sens	Total	Sens	Total	Sens	Total	Sens	Total	Sens
700 / 0.11	57 (13.9)	22.38	22.38	1.57	21.54	21.54	1.78	20.63	20.63	2.01	19.64	19.64	2.27	18.54	18.54	2.56	17.33	17.33	2.88
	62 (16.7)	23.32	21.00	1.58	22.26	20.45	1.79	21.13	19.85	2.02	19.92	19.18	2.27	18.63	18.50	2.56	17.36	17.36	2.88
	63* (17.2)	23.73	17.21	1.58	22.64	16.69	1.79	21.47	16.14	2.02	20.21	15.55	2.27	18.82	14.89	2.56	17.32	14.19	2.88
	67 (19.4)	25.65	17.94	1.60	24.48	17.42	1.81	23.23	16.87	2.04	21.88	16.28	2.30	20.41	15.64	2.58	18.80	14.93	2.89
	72 (13.9)	28.26	14.67	1.65	26.98	14.19	1.86	25.61	13.68	2.08	24.14	13.14	2.34	22.52	12.55	2.62	20.77	11.88	2.93
800 / 0.15	57 (13.9)	23.50	23.50	1.60	22.59	22.59	1.81	21.61	21.61	2.04	20.54	20.54	2.30	19.37	19.37	2.58	18.07	18.07	2.90
	62 (16.7)	24.02	22.63	1.60	22.92	22.02	1.81	21.77	21.32	2.04	20.58	20.58	2.30	19.40	19.40	2.58	18.10	18.10	2.90
	63* (17.2)	24.39	18.39	1.61	23.24	17.85	1.81	22.02	17.28	2.04	20.69	16.67	2.30	19.25	15.98	2.58	17.68	15.23	2.90
	67 (19.4)	26.34	19.21	1.63	25.11	18.67	1.84	23.80	18.10	2.07	22.38	17.48	2.32	20.84	16.81	2.60	19.17	16.06	2.92
	72 (13.9)	29.00	15.54	1.68	27.64	15.04	1.89	26.19	14.53	2.12	24.66	13.93	2.37	22.98	13.29	2.65	21.15	12.59	2.95
900 / 0.20	57 (13.9)	24.45	24.45	1.63	23.48	23.48	1.84	22.45	22.45	2.07	21.31	21.31	2.32	20.06	20.06	2.61	18.69	18.69	2.93
	62 (16.7)	24.64	24.10	1.63	23.54	23.54	1.84	22.49	22.49	2.07	21.34	21.34	2.32	20.10	20.10	2.61	18.71	18.71	2.93
	63* (17.2)	24.92	19.53	1.63	23.72	18.97	1.84	22.45	18.37	2.07	21.07	17.72	2.32	19.58	17.01	2.60	17.97	16.22	2.92
	67 (19.4)	26.89	20.43	1.66	25.60	19.87	1.87	24.25	19.27	2.10	22.78	18.63	2.35	21.18	17.93	2.63	19.46	17.14	2.94
	72 (13.9)	29.56	16.36	1.71	28.16	15.83	1.92	26.67	15.26	2.15	25.07	14.65	2.40	23.33	13.99	2.67	21.45	13.27	2.98

*At 75°F (23.9 °C) entering dry bulb—Tennessee Valley Authority [TVA] rating conditions; all others at 80°F (26.7 °C) entering dry bulb. See Legend and Notes.

PHD324 HEATING EXTENDED PERFORMANCE TABLE																																		
INDOOR AIR			OUTDOOR COIL ENTERING AIR TEMPERATURES °F (°C)																															
			-10 (-23.3)				0 (-17.8)				10 (-12.2)				20 (-6.7)				30 (-1.1)				40 (4.4)				50 (10)				60 (15.6)			
			Capacity MBtuh		Total Sys KW	Capacity MBtuh		Total Sys KW	Capacity MBtuh		Total Sys KW	Capacity MBtuh		Total Sys KW	Capacity MBtuh		Total Sys KW	Capacity MBtuh		Total Sys KW	Capacity MBtuh		Total Sys KW	Capacity MBtuh		Total Sys KW								
EDB °F (°C)	CFM	Total	Integ	Total	Integ	Total	Integ	Total	Integ	Total	Integ	Total	Integ	Total	Integ	Total	Integ	Total	Integ	Total	Integ	Total	Integ											
65	700	7.81	7.18	1.51	10.21	9.39	1.62	13.03	11.96	1.71	15.49	14.05	1.76	18.20	15.95	1.81	21.29	21.29	1.87	24.98	24.98	1.97	29.37	29.37	2.13									
	800	7.93	7.29	1.51	10.35	9.52	1.62	13.17	12.09	1.70	15.63	14.18	1.74	18.38	16.11	1.78	21.53	21.53	1.83	25.30	25.30	1.92	29.63	29.63	2.05									
	900	8.02	7.38	1.52	10.45	9.62	1.62	13.28	12.19	1.69	15.76	14.29	1.73	18.54	16.24	1.76	21.73	21.73	1.80	25.52	25.52	1.89	29.60	29.60	2.02									
70	700	7.49	6.89	1.59	9.88	9.10	1.70	12.47	11.44	1.79	15.29	13.87	1.86	17.96	15.74	1.91	20.99	20.99	1.97	24.59	24.59	2.07	28.92	28.92	2.23									
	800	7.61	7.00	1.59	10.04	9.24	1.70	12.72	11.68	1.78	15.43	14.00	1.83	18.14	15.89	1.87	21.22	21.22	1.93	24.90	24.90	2.02	29.27	29.27	2.16									
	900	7.71	7.09	1.59	10.16	9.35	1.70	12.88	11.82	1.77	15.55	14.10	1.82	18.28	16.02	1.85	21.42	21.42	1.90	25.15	25.15	1.99	29.31	29.31	2.12									
75	700	7.14	6.57	1.67	9.56	8.80	1.79	12.14	11.14	1.88	15.07	13.67	1.96	17.72	15.52	2.01	20.69	20.69	2.08	24.22	24.22	2.18	28.47	28.47	2.34									
	800	7.25	6.67	1.67	9.71	8.93	1.78	12.31	11.30	1.86	15.22	13.81	1.93	17.89	15.68	1.98	20.92	20.92	2.03	24.53	24.53	2.12	28.86	28.86	2.28									
	900	7.37	6.78	1.67	9.83	9.04	1.78	12.46	11.43	1.86	15.35	13.92	1.92	18.04	15.81	1.95	21.11	21.11	2.00	24.76	24.76	2.09	28.98	28.98	2.22									

See Legend and Notes following tables.

PHD330 COOLING EXTENDED PERFORMANCE TABLE

EVAPORATOR AIR		CONDENSER ENTERING AIR TEMPERATURES °F (°C)																	
		75 (23.9)			85 (29.4)			95 (35)			105 (40.5)			115 (46.1)			125 (51.7)		
		Capacity MBtuh		Total Sys KW	Capacity MBtuh		Total Sys KW	Capacity MBtuh		Total Sys KW	Capacity MBtuh		Total Sys KW	Capacity MBtuh		Total Sys KW	Capacity MBtuh		Total Sys KW
CFM / BF	EWB °F (°C)	Total	Sens		Total	Sens		Total	Sens		Total	Sens		Total	Sens		Total	Sens	
875 / 0.13	57 (13.9)	27.44	27.44	2.00	26.40	26.40	2.22	25.31	25.31	2.47	24.13	24.13	2.75	22.83	22.83	3.07	21.42	21.42	3.44
	62 (16.7)	28.39	25.49	2.00	27.09	24.83	2.22	25.75	24.11	2.47	24.34	23.30	2.75	22.88	22.88	3.07	21.45	21.45	3.44
	63* (17.2)	28.86	20.79	2.00	27.53	20.17	2.22	26.13	19.52	2.47	24.63	18.84	2.75	23.00	18.09	3.07	21.25	17.29	3.44
	67 (19.4)	31.27	21.73	2.02	29.83	21.10	2.24	28.33	20.46	2.49	26.73	19.77	2.76	25.00	19.04	3.08	23.14	18.24	3.45
	72 (13.9)	34.57	17.68	2.04	32.97	17.10	2.26	31.32	16.50	2.51	29.56	15.87	2.79	27.68	15.20	3.10	25.66	14.44	3.46
1000 / 0.17	57 (13.9)	28.78	28.78	2.04	27.67	27.67	2.26	26.49	26.49	2.50	25.23	25.23	2.78	23.84	23.84	3.11	22.33	22.33	3.47
	62 (16.7)	29.25	27.45	2.04	27.91	26.71	2.26	26.55	26.55	2.50	25.27	25.27	2.79	23.88	23.88	3.11	22.37	22.37	3.47
	63* (17.2)	29.64	22.24	2.04	28.24	21.59	2.26	26.76	20.92	2.51	25.20	20.20	2.78	23.51	19.42	3.10	21.69	18.56	3.47
	67 (19.4)	32.09	23.29	2.05	30.58	22.64	2.28	29.00	21.96	2.52	27.32	21.25	2.80	25.54	20.48	3.12	23.60	19.64	3.48
	72 (13.9)	35.47	18.74	2.08	33.78	18.14	2.30	32.02	17.52	2.55	30.20	16.83	2.82	28.25	16.11	3.14	26.14	15.32	3.49
1125 / 0.21	57 (13.9)	29.95	29.95	2.07	28.75	28.75	2.29	27.50	27.50	2.54	26.15	26.15	2.82	24.69	24.69	3.14	23.10	23.10	3.51
	62 (16.7)	30.03	30.03	2.07	28.81	28.81	2.30	27.55	27.55	2.54	26.20	26.20	2.82	24.73	24.73	3.14	23.14	23.14	3.51
	63* (17.2)	30.27	23.63	2.07	28.80	22.96	2.29	27.27	22.26	2.54	25.65	21.50	2.82	23.91	20.68	3.14	22.05	19.77	3.50
	67 (19.4)	32.74	24.80	2.09	31.17	24.11	2.31	29.54	23.41	2.56	27.80	22.67	2.83	25.95	21.86	3.15	23.97	20.96	3.51
	72 (13.9)	36.13	19.76	2.11	34.40	19.10	2.34	32.60	18.43	2.58	30.70	17.73	2.86	28.69	16.98	3.17	26.51	16.17	3.53

*At 75°F (23.9 °C) entering dry bulb—Tennessee Valley Authority [TVA] rating conditions; all others at 80°F (26.7 °C) entering dry bulb. See Legend and Notes.

PHD330 HEATING EXTENDED PERFORMANCE TABLE

INDOOR AIR		OUTDOOR COIL ENTERING AIR TEMPERATURES °F (°C)																															
		-10 (-23.3)				0 (-17.8)				10 (-12.2)				20 (-6.7)				30 (-1.1)				40 (4.4)				50 (10)				60 (15.6)			
		EDB °F (°C)	CFM	Capacity MBtuh		Total Sys KW	Capacity MBtuh		Total Sys KW	Capacity MBtuh		Total Sys KW	Capacity MBtuh		Total Sys KW	Capacity MBtuh		Total Sys KW	Capacity MBtuh		Total Sys KW	Capacity MBtuh		Total Sys em KW	Capacity MBtuh		Total Sys em KW						
Total	Integ			Total	Integ		Total	Integ		Total	Integ		Total	Integ		Total	Integ		Total	Integ		Total	Integ		Total	Integ							
65	875	8.58	7.89	1.91	11.60	10.67	1.98	14.83	13.61	2.04	18.37	16.66	2.12	22.35	19.58	2.21	26.08	26.08	2.29	30.29	30.29	2.39	35.28	35.28	2.52								
	1000	8.75	8.05	1.92	11.81	10.87	1.99	15.07	13.83	2.05	18.71	16.97	2.11	22.60	19.80	2.19	26.39	26.39	2.26	30.70	30.70	2.35	35.83	35.83	2.47								
	1125	8.92	8.20	1.95	11.99	11.04	2.00	15.28	14.02	2.06	19.32	17.52	2.12	22.81	19.98	2.18	26.65	26.65	2.24	31.04	31.04	2.32	36.29	36.29	2.43								
70	875	8.06	7.42	1.98	11.12	10.23	2.06	14.37	13.19	2.13	17.90	16.23	2.21	22.07	19.33	2.31	25.74	25.74	2.40	29.87	29.87	2.50	34.73	34.73	2.64								
	1000	8.24	7.58	2.00	11.33	10.42	2.07	14.62	13.42	2.14	18.19	16.49	2.20	22.30	19.54	2.29	26.03	26.03	2.36	30.27	30.27	2.46	35.27	35.27	2.58								
	1125	8.40	7.73	2.02	11.51	10.59	2.09	14.83	13.61	2.15	18.43	16.71	2.21	22.51	19.72	2.28	26.29	26.29	2.35	30.57	30.57	2.43	35.70	35.70	2.54								
75	875	7.50	6.90	2.06	10.60	9.76	2.15	13.88	12.74	2.22	17.41	15.79	2.31	21.72	19.03	2.42	25.38	25.38	2.51	29.46	29.46	2.62	34.18	34.18	2.75								
	1000	7.68	7.06	2.08	10.81	9.95	2.16	14.13	12.97	2.23	17.69	16.05	2.30	21.99	19.27	2.40	25.68	25.68	2.48	29.83	29.83	2.57	34.70	34.70	2.69								
	1125	7.84	7.21	2.11	11.00	10.12	2.18	14.34	13.16	2.24	17.94	16.27	2.30	22.21	19.46	2.39	25.93	25.93	2.46	30.13	30.13	2.54	35.14	35.14	2.66								

See Legend and Notes following tables.

PHD336 COOLING EXTENDED PERFORMANCE TABLE

EVAPORATOR AIR		CONDENSER ENTERING AIR TEMPERATURES °F (°C)																	
		75 (23.9)			85 (29.4)			95 (35)			105 (40.5)			115 (46.1)			125 (51.7)		
		Capacity MBtuh		Total Sys KW	Capacity MBtuh		Total Sys KW	Capacity MBtuh		Total Sys KW	Capacity MBtuh		Total Sys KW	Capacity MBtuh		Total Sys KW	Capacity MBtuh		Total Sys KW
CFM / BF	EWB °F (°C)	Total	Sens	Total	Sens	Total	Sens	Total	Sens	Total	Sens	Total	Sens	Total	Sens	Total	Sens	Total	Sens
1050 / 0.12	57 (13.9)	33.59	33.59	2.41	32.25	32.25	2.67	30.82	30.82	2.96	29.24	29.24	3.28	27.50	27.50	3.66	25.58	25.58	4.08
	62 (16.7)	34.77	30.70	2.42	33.10	29.87	2.67	31.33	28.94	2.96	29.46	27.90	3.29	27.56	27.56	3.66	25.62	25.62	4.08
	63* (17.2)	35.34	25.01	2.42	33.64	24.23	2.68	31.81	23.40	2.96	29.83	22.52	3.29	27.67	21.55	3.66	25.33	20.50	4.08
	67 (19.4)	38.13	26.06	2.44	36.31	25.28	2.70	34.33	24.46	2.99	32.20	23.57	3.31	29.86	22.59	3.68	27.36	21.54	4.10
	72 (13.9)	41.96	21.04	2.47	39.94	20.31	2.74	37.75	19.54	3.03	35.39	18.70	3.35	32.82	17.81	3.71	30.05	16.85	4.12
1200 / 0.18	57 (13.9)	35.11	35.11	2.47	33.69	33.69	2.73	32.14	32.14	3.02	30.45	30.45	3.34	28.57	28.57	3.71	26.49	26.49	4.14
	62 (16.7)	35.71	33.01	2.47	33.97	32.07	2.73	32.20	32.20	3.02	30.50	30.50	3.34	28.61	28.61	3.71	26.53	26.53	4.14
	63* (17.2)	36.21	26.69	2.47	34.40	25.89	2.73	32.47	25.03	3.02	30.40	24.10	3.34	28.14	23.09	3.71	25.72	21.97	4.13
	67 (19.4)	38.99	27.86	2.50	37.07	27.06	2.76	35.00	26.20	3.04	32.76	25.27	3.37	30.32	24.25	3.73	27.71	23.14	4.15
	72 (13.9)	42.86	22.23	2.53	40.74	21.48	2.79	38.42	20.68	3.08	35.93	19.82	3.40	33.26	18.85	3.76	30.40	17.82	4.17
1350 / 0.24	57 (13.9)	36.41	36.41	2.52	34.89	34.89	2.78	33.23	33.23	3.07	31.42	31.42	3.40	29.41	29.41	3.77	27.22	27.22	4.19
	62 (16.7)	36.54	36.49	2.53	34.95	34.95	2.79	33.28	33.28	3.07	31.47	31.47	3.40	29.45	29.45	3.77	27.25	27.25	4.19
	63* (17.2)	36.85	28.29	2.53	34.96	27.46	2.78	32.97	26.58	3.07	30.82	25.61	3.39	28.48	24.53	3.76	26.00	23.34	4.18
	67 (19.4)	39.63	29.59	2.55	37.64	28.75	2.81	35.49	27.86	3.10	33.16	26.89	3.42	30.65	25.82	3.78	27.98	24.63	4.20
	72 (13.9)	43.50	23.36	2.58	41.27	22.59	2.85	38.89	21.74	3.13	36.32	20.81	3.45	33.56	19.82	3.82	30.62	18.76	4.22

*At 75°F (23.9 °C) entering dry bulb—Tennessee Valley Authority [TVA] rating conditions; all others at 80°F (26.7 °C) entering dry bulb. See Legend and Notes.

PHD336 HEATING EXTENDED PERFORMANCE TABLE

INDOOR AIR		OUTDOOR COIL ENTERING AIR TEMPERATURES °F (°C)																															
		-10 (-23.3)				0 (-17.8)				10 (-12.2)				20 (-6.7)				30 (-1.1)				40 (4.4)				50 (10)				60 (15.6)			
		Capacity MBtuh		Total Sys KW	Capacity MBtuh		Total Sys KW	Capacity MBtuh		Total Sys KW	Capacity MBtuh		Total Sys KW	Capacity MBtuh		Total Sys KW	Capacity MBtuh		Total Sys KW	Capacity MBtuh		Total Sys KW	Capacity MBtuh		Total Sys KW	Capacity MBtuh		Total Sys KW					
EDB °F (°C)	CFM	Total	Integ	Total	Integ	Total	Integ	Total	Integ	Total	Integ	Total	Integ	Total	Integ	Total	Integ	Total	Integ	Total	Integ	Total	Integ	Total	Integ								
65	1050	12.15	11.18	2.30	15.31	14.08	2.39	19.19	17.61	2.49	22.68	20.57	2.58	26.68	23.38	2.68	31.28	31.28	2.80	36.70	36.70	2.96	42.99	42.99	3.16								
	1200	12.38	11.39	2.32	15.57	14.32	2.40	19.41	17.82	2.50	22.96	20.82	2.58	27.01	23.66	2.67	31.68	31.68	2.78	37.20	37.20	2.94	43.06	43.06	3.12								
	1350	12.59	11.58	2.35	15.79	14.53	2.43	19.62	18.01	2.52	23.19	21.03	2.59	27.29	23.91	2.67	32.01	32.01	2.78	37.51	37.51	2.93	42.82	42.82	3.10								
70	1050	11.71	10.77	2.41	14.88	13.69	2.50	18.76	17.22	2.61	22.39	20.31	2.70	26.32	23.06	2.80	30.81	30.81	2.93	36.14	36.14	3.09	42.42	42.42	3.31								
	1200	11.94	10.99	2.44	15.13	13.93	2.52	19.13	17.55	2.62	22.65	20.54	2.70	26.63	23.34	2.79	31.21	31.21	2.91	36.62	36.62	3.06	42.62	42.62	3.25								
	1350	12.15	11.18	2.47	15.37	14.14	2.54	19.35	17.76	2.64	22.88	20.75	2.71	26.91	23.58	2.80	31.54	31.54	2.91	37.00	37.00	3.06	42.49	42.49	3.24								
75	1050	11.23	10.33	2.53	14.42	13.27	2.62	18.01	16.53	2.72	22.09	20.03	2.84	25.96	22.75	2.94	30.36	30.36	3.06	35.58	35.58	3.23	41.77	41.77	3.46								
	1200	11.46	10.55	2.56	14.68	13.51	2.64	18.31	16.81	2.73	22.36	20.27	2.83	26.27	23.02	2.92	30.74	30.74	3.04	36.04	36.04	3.19	42.15	42.15	3.40								
	1350	11.67	10.74	2.59	14.91	13.72	2.67	18.61	17.08	2.75	22.59	20.48	2.84	26.53	23.24	2.93	31.07	31.07	3.03	36.43	36.43	3.19	42.11	42.11	3.38								

See Legend and Notes following tables.

PHD342 COOLING EXTENDED PERFORMANCE TABLE																			
EVAPORATOR AIR		CONDENSER ENTERING AIR TEMPERATURES °F (°C)																	
		75 (23.9)			85 (29.4)			95 (35)			105 (40.5)			115 (46.1)			125 (51.7)		
		Capacity MBtuh		Total Sys KW	Capacity MBtuh		Total Sys KW	Capacity MBtuh		Total Sys KW	Capacity MBtuh		Total Sys KW	Capacity MBtuh		Total Sys KW	Capacity MBtuh		Total Sys KW
CFM / BF	EWB °F (°C)	Total	Sens	Total	Sens	Total	Sens	Total	Sens	Total	Sens	Total	Sens	Total	Sens	Total	Sens	Total	Sens
1225 / 0.14	57 (13.9)	38.29	38.29	2.70	36.78	36.78	3.00	35.17	35.17	3.35	33.43	33.43	3.76	31.55	31.55	4.23	29.53	29.53	4.78
	62 (16.7)	39.60	35.26	2.71	37.74	34.27	3.01	35.79	33.19	3.36	33.74	32.00	3.76	31.62	31.62	4.24	29.58	29.58	4.78
	63* (17.2)	40.17	28.70	2.72	38.23	27.80	3.02	36.20	26.84	3.37	34.04	25.81	3.77	31.75	24.73	4.24	29.30	23.57	4.77
	67 (19.4)	43.43	29.99	2.76	41.34	29.07	3.07	39.13	28.10	3.42	36.80	27.07	3.83	34.33	25.98	4.30	31.69	24.82	4.85
	72 (13.9)	47.71	24.52	2.83	45.36	23.64	3.14	42.91	22.69	3.50	40.34	21.70	3.91	37.63	20.65	4.40	34.75	19.54	4.95
1400 / 0.17	57 (13.9)	40.11	40.11	2.76	38.48	38.48	3.06	36.73	36.73	3.42	34.85	34.85	3.83	32.83	32.83	4.31	30.65	30.65	4.86
	62 (16.7)	40.77	37.93	2.77	38.83	36.81	3.07	36.82	36.82	3.42	34.91	34.91	3.83	32.88	32.88	4.31	30.69	30.69	4.86
	63* (17.2)	41.23	30.65	2.77	39.19	29.70	3.07	37.04	28.70	3.42	34.77	27.63	3.83	32.38	26.48	4.29	29.83	25.25	4.83
	67 (19.4)	44.54	32.09	2.82	42.33	31.12	3.12	40.00	30.10	3.48	37.55	29.02	3.89	34.97	27.89	4.37	32.23	26.64	4.91
	72 (13.9)	48.87	25.87	2.89	46.39	24.92	3.20	43.82	23.93	3.56	41.13	22.89	3.98	38.30	21.80	4.46	35.30	20.64	5.02
1575 / 0.19	57 (13.9)	41.67	41.67	2.82	39.92	39.92	3.13	38.04	38.04	3.48	36.04	36.04	3.90	33.89	33.89	4.38	31.57	31.57	4.93
	62 (16.7)	41.78	41.78	2.82	40.00	40.00	3.13	38.10	38.10	3.49	36.09	36.09	3.90	33.94	33.94	4.38	31.61	31.61	4.94
	63* (17.2)	42.07	32.53	2.83	39.93	31.53	3.13	37.70	30.48	3.48	35.35	29.35	3.88	32.87	28.13	4.35	30.26	26.81	4.89
	67 (19.4)	45.42	34.11	2.87	43.10	33.11	3.18	40.66	32.04	3.53	38.14	30.89	3.95	35.47	29.68	4.43	32.65	28.36	4.97
	72 (13.9)	49.79	27.12	2.95	47.20	26.14	3.26	44.53	25.11	3.62	41.74	24.03	4.04	38.81	22.90	4.53	35.71	21.70	5.08

*At 75°F (23.9 °C) entering dry bulb—Tennessee Valley Authority [TVA] rating conditions; all others at 80°F (26.7 °C) entering dry bulb. See Legend and Notes.

PHD342 HEATING EXTENDED PERFORMANCE TABLE																																		
INDOOR AIR			OUTDOOR COIL ENTERING AIR TEMPERATURES °F (°C)																															
			-10 (-23.3)				0 (-17.8)				10 (-12.2)				20 (-6.7)				30 (-1.1)				40 (4.4)				50 (10)				60 (15.6)			
			Capacity MBtuh		Total Sys KW	Capacity MBtuh		Total Sys KW	Capacity MBtuh		Total Sys KW	Capacity MBtuh		Total Sys KW	Capacity MBtuh		Total Sys KW	Capacity MBtuh		Total Sys KW	Capacity MBtuh		Total Sys KW	Capacity MBtuh		Total Sys KW								
EDB °F (°C)	CFM	Total	Integ	Total	Integ	Total	Integ	Total	Integ	Total	Integ	Total	Integ	Total	Integ	Total	Integ	Total	Integ	Total	Integ	Total	Integ											
65	1225	13.54	12.46	2.47	17.47	16.08	2.63	21.96	20.15	2.78	25.98	23.56	2.88	30.54	26.76	2.98	35.78	35.78	3.11	42.01	42.01	3.30	48.77	48.77	3.53									
	1400	13.72	12.62	2.48	17.68	16.26	2.64	22.14	20.32	2.77	26.21	23.77	2.86	30.85	27.03	2.95	36.18	36.18	3.07	42.43	42.43	3.24	48.15	48.15	3.46									
	1575	13.88	12.77	2.50	17.85	16.43	2.65	22.30	20.47	2.78	26.41	23.95	2.86	31.10	27.25	2.95	36.50	36.50	3.07	42.12	42.12	3.22	47.19	47.19	3.42									
70	1225	13.21	12.15	2.61	17.11	15.75	2.77	21.74	19.96	2.92	25.70	23.30	3.02	30.15	26.42	3.12	35.27	35.27	3.25	41.37	41.37	3.44	48.32	48.32	3.70									
	1400	13.40	12.33	2.62	17.33	15.95	2.78	21.94	20.14	2.91	25.93	23.52	3.00	30.45	26.68	3.10	35.67	35.67	3.22	41.86	41.86	3.40	47.84	47.84	3.62									
	1575	13.57	12.48	2.64	17.52	16.12	2.79	22.13	20.31	2.92	26.14	23.71	3.00	30.72	26.91	3.09	35.97	35.97	3.21	41.84	41.84	3.37	47.03	47.03	3.59									
75	1225	12.79	11.77	2.75	16.70	15.37	2.91	21.03	19.31	3.05	25.41	23.05	3.17	29.76	26.07	3.27	34.76	34.76	3.41	40.75	40.75	3.61	47.80	47.80	3.89									
	1400	12.99	11.95	2.76	16.93	15.58	2.92	21.59	19.82	3.05	25.64	23.25	3.15	30.06	26.34	3.24	35.15	35.15	3.37	41.24	41.24	3.56	47.49	47.49	3.80									
	1575	13.17	12.12	2.79	17.13	15.76	2.93	21.86	20.07	3.06	25.85	23.44	3.15	30.31	26.56	3.23	35.46	35.46	3.35	41.48	41.48	3.53	46.79	46.79	3.76									

See Legend and Notes following tables.

PHD348 COOLING EXTENDED PERFORMANCE TABLE

EVAPORATOR AIR		CONDENSER ENTERING AIR TEMPERATURES °F (°C)																	
		75 (23.9)			85 (29.4)			95 (35)			105 (40.5)			115 (46.1)			125 (51.7)		
		Capacity MBtuh		Total Sys KW	Capacity MBtuh		Total Sys KW	Capacity MBtuh		Total Sys KW	Capacity MBtuh		Total Sys KW	Capacity MBtuh		Total Sys KW	Capacity MBtuh		Total Sys KW
CFM / BF	EWB °F (°C)	Total	Sens	Total	Sens	Total	Sens	Total	Sens	Total	Sens	Total	Sens	Total	Sens	Total	Sens	Total	Sens
1400 / 0.15	57 (13.9)	45.56	45.56	3.20	43.64	43.64	3.58	41.62	41.62	3.98	39.47	39.47	4.41	37.15	37.15	4.90	34.64	34.64	5.46
	62 (16.7)	47.12	41.32	3.21	44.75	40.06	3.59	42.33	38.74	3.99	39.81	37.27	4.42	37.23	37.23	4.91	34.69	34.69	5.46
	63* (17.2)	47.82	33.66	3.21	45.36	32.52	3.59	42.84	31.34	3.99	40.19	30.11	4.42	37.38	28.81	4.91	34.39	27.41	5.46
	67 (19.4)	51.57	35.10	3.22	48.88	33.93	3.62	46.13	32.74	4.02	43.25	31.49	4.46	40.21	30.17	4.95	36.94	28.75	5.49
	72 (13.9)	56.55	28.57	3.23	53.52	27.50	3.64	50.45	26.34	4.06	47.26	25.12	4.51	43.85	23.83	4.99	40.27	22.48	5.53
1600 / 0.18	57 (13.9)	47.60	47.60	3.26	45.50	45.50	3.65	43.31	43.31	4.05	40.98	40.98	4.49	38.48	38.48	4.98	35.76	35.76	5.53
	62 (16.7)	48.40	44.34	3.26	45.91	42.93	3.65	43.41	43.41	4.05	41.04	41.04	4.49	38.53	38.53	4.98	35.81	35.81	5.53
	63* (17.2)	48.97	35.87	3.27	46.36	34.67	3.65	43.69	33.44	4.05	40.92	32.15	4.49	37.98	30.76	4.97	34.88	29.27	5.52
	67 (19.4)	52.75	37.49	3.27	49.90	36.26	3.68	47.00	35.00	4.09	43.98	33.69	4.52	40.79	32.28	5.01	37.41	30.77	5.55
	72 (13.9)	57.75	30.14	3.28	54.58	28.93	3.70	51.36	27.71	4.13	48.01	26.44	4.57	44.45	25.09	5.06	40.74	23.69	5.59
1800 / 0.21	57 (13.9)	49.32	49.32	3.32	47.06	47.06	3.71	44.71	44.71	4.12	42.23	42.23	4.56	39.55	39.55	5.05	36.65	36.65	5.59
	62 (16.7)	49.55	49.16	3.32	47.14	47.14	3.71	44.77	44.77	4.12	42.28	42.28	4.56	39.60	39.60	5.05	36.70	36.70	5.59
	63* (17.2)	49.85	38.00	3.32	47.12	36.74	3.71	44.35	35.44	4.11	41.47	34.07	4.55	38.44	32.60	5.03	35.24	30.98	5.57
	67 (19.4)	53.64	39.78	3.32	50.67	38.49	3.73	47.66	37.17	4.15	44.52	35.78	4.59	41.22	34.28	5.07	37.75	32.65	5.60
	72 (13.9)	58.69	31.53	3.33	55.39	30.29	3.76	52.04	29.02	4.18	48.54	27.70	4.63	44.88	26.31	5.12	41.06	24.85	5.65

*At 75°F (23.9 °C) entering dry bulb—Tennessee Valley Authority [TVA] rating conditions; all others at 80°F (26.7 °C) entering dry bulb. See Legend and Notes.

PHD348 HEATING EXTENDED PERFORMANCE TABLE

INDOOR AIR		OUTDOOR COIL ENTERING AIR TEMPERATURES °F (°C)																															
		-10 (-23.3)				0 (-17.8)				10 (-12.2)				20 (-6.7)				30 (-1.1)				40 (4.4)				50 (10)				60 (15.6)			
		Capacity MBtuh		Total Sys KW	Capacity MBtuh		Total Sys KW	Capacity MBtuh		Total Sys KW	Capacity MBtuh		Total Sys KW	Capacity MBtuh		Total Sys KW	Capacity MBtuh		Total Sys KW	Capacity MBtuh		Total Sys KW	Capacity MBtuh		Total Sys KW	Capacity MBtuh		Total Sys KW					
EDB °F (°C)	CFM	Total	Integ	Total	Integ	Total	Integ	Total	Integ	Total	Integ	Total	Integ	Total	Integ	Total	Integ	Total	Integ	Total	Integ	Total	Integ	Total	Integ								
65 (18.3)	1400	15.76	14.50	2.95	20.36	18.74	3.07	25.22	23.15	3.20	31.05	28.16	3.36	36.22	31.73	3.50	41.94	41.94	3.65	48.55	48.55	3.83	56.41	56.41	4.05								
	1600	16.01	14.73	2.98	20.64	18.99	3.09	25.55	23.46	3.21	31.36	28.44	3.35	36.59	32.06	3.48	42.42	42.42	3.61	49.17	49.17	3.77	57.12	57.12	3.95								
	1800	16.24	14.94	3.02	20.90	19.23	3.12	25.85	23.73	3.23	31.63	28.69	3.37	36.92	32.35	3.48	42.84	42.84	3.60	49.72	49.72	3.74	57.48	57.48	3.90								
70 (21.1)	1400	15.26	14.04	3.08	19.85	18.27	3.20	24.68	22.65	3.33	30.13	27.32	3.48	35.80	31.37	3.65	41.40	41.40	3.81	47.87	47.87	4.00	55.58	55.58	4.24								
	1600	15.52	14.28	3.11	20.14	18.53	3.22	25.04	22.98	3.34	30.99	28.11	3.50	36.16	31.68	3.63	41.87	41.87	3.78	48.48	48.48	3.94	56.38	56.38	4.15								
	1800	15.76	14.50	3.15	20.41	18.78	3.25	25.33	23.25	3.36	31.28	28.37	3.51	36.49	31.97	3.63	42.28	42.28	3.76	49.01	49.01	3.91	56.82	56.82	4.09								
75 (23.9)	1400	14.68	13.51	3.22	19.29	17.74	3.34	24.12	22.14	3.47	29.34	26.61	3.63	35.38	31.00	3.82	40.85	40.85	3.98	47.21	47.21	4.18	54.77	54.77	4.43								
	1600	14.95	13.76	3.25	19.59	18.03	3.36	24.47	22.46	3.48	29.76	26.99	3.62	35.73	31.31	3.79	41.31	41.31	3.94	47.80	47.80	4.12	55.56	55.56	4.35								
	1800	15.19	13.98	3.29	19.85	18.27	3.39	24.78	22.74	3.51	30.19	27.38	3.63	36.07	31.60	3.79	41.72	41.72	3.93	48.30	48.30	4.09	56.12	56.12	4.28								

See Legend and Notes following tables.

PHD360 COOLING EXTENDED PERFORMANCE TABLE

EVAPORATOR AIR		CONDENSER ENTERING AIR TEMPERATURES °F (°C)																	
		75 (23.9)			85 (29.4)			95 (35)			105 (40.5)			115 (46.1)			125 (51.7)		
		CFM / BF	EWB °F (°C)	Capacity MBtuh		Total Sys KW	Capacity MBtuh		Total Sys KW	Capacity MBtuh		Total Sys KW	Capacity MBtuh		Total Sys KW	Capacity MBtuh		Total Sys KW	Capacity MBtuh
Total	Sens			Total	Sens	Total	Sens	Total	Sens	Total	Sens	Total	Sens	Total	Sens	Total	Sens	Total	Sens
1750 / 0.19	57 (13.9)	56.42	56.42	3.97	54.09	54.09	4.39	51.60	51.60	4.86	48.89	48.89	5.40	45.87	45.87	6.01	42.60	42.60	6.70
	62 (16.7)	58.00	51.82	3.99	55.15	50.34	4.40	52.19	48.67	4.87	49.10	48.72	5.40	45.94	45.94	6.01	42.66	42.66	6.70
	63* (17.2)	58.78	42.05	4.00	55.87	40.69	4.41	52.77	39.25	4.88	49.45	37.72	5.41	45.84	36.06	6.01	42.01	34.26	6.69
	67 (19.4)	63.34	43.86	4.05	60.17	42.48	4.47	56.78	41.02	4.94	53.14	39.45	5.46	49.23	37.77	6.06	45.09	35.96	6.74
	72 (13.9)	69.39	35.42	4.13	65.81	34.15	4.55	62.02	32.72	5.02	57.99	31.19	5.54	53.69	29.56	6.13	49.14	27.85	6.80
1850 / 0.20	57 (13.9)	56.94	56.94	3.99	54.57	54.57	4.41	52.03	52.03	4.88	49.27	49.27	5.42	46.23	46.23	6.03	42.88	42.88	6.72
	62 (16.7)	58.33	52.61	4.01	55.44	51.08	4.42	52.47	49.35	4.89	49.36	49.36	5.42	46.30	46.30	6.03	42.94	42.94	6.72
	63* (17.2)	59.07	42.62	4.02	56.12	41.24	4.43	53.00	39.80	4.90	49.63	38.25	5.42	45.98	36.56	6.03	42.13	34.74	6.71
	67 (19.4)	63.63	44.47	4.08	60.42	43.08	4.49	57.00	41.60	4.96	53.31	40.02	5.48	49.37	38.31	6.08	45.20	36.48	6.75
	72 (13.9)	69.68	35.83	4.15	66.07	34.51	4.57	62.25	33.07	5.04	58.17	31.52	5.56	53.84	29.88	6.15	49.25	28.16	6.82
2250 / 0.27	57 (13.9)	60.87	60.87	4.19	58.14	58.14	4.61	55.23	55.23	5.08	52.05	52.05	5.62	48.61	48.61	6.22	44.88	44.88	6.90
	62 (16.7)	60.95	60.95	4.19	58.23	58.23	4.61	55.31	55.31	5.08	52.12	52.12	5.62	48.67	48.67	6.22	44.93	44.93	6.90
	63* (17.2)	61.07	47.50	4.19	57.83	46.01	4.61	54.45	44.43	5.07	50.81	42.69	5.60	46.95	40.79	6.19	42.89	38.69	6.87
	67 (19.4)	65.61	49.74	4.25	62.14	48.23	4.67	58.42	46.60	5.13	54.47	44.84	5.66	50.28	42.93	6.25	45.90	40.82	6.92
	72 (13.9)	71.73	39.07	4.33	67.82	37.60	4.75	63.70	36.05	5.21	59.34	34.41	5.74	54.72	32.67	6.32	49.88	30.83	6.98

*At 75°F (23.9 °C) entering dry bulb—Tennessee Valley Authority [TVA] rating conditions; all others at 80°F (26.7 °C) entering dry bulb. See Legend and Notes.

PHD360 HEATING EXTENDED PERFORMANCE TABLE

INDOOR AIR		OUTDOOR COIL ENTERING AIR TEMPERATURES °F (°C)																															
		-10 (-23.3)				0 (-17.8)				10 (-12.2)				20 (-6.7)				30 (-1.1)				40 (4.4)				50 (10)				60 (15.6)			
		EDB °F (°C)	CFM	Capacity MBtuh		Total Sys KW	Capacity MBtuh		Total Sys KW	Capacity MBtuh		Total Sys KW	Capacity MBtuh		Total Sys KW	Capacity MBtuh		Total Sys KW	Capacity MBtuh		Total Sys KW	Capacity MBtuh		Total Sys KW	Capacity MBtuh		Total Sys KW						
Total	Integ			Total	Integ	Total	Integ	Total	Integ	Total	Integ	Total	Integ	Total	Integ	Total	Integ	Total	Integ	Total	Integ	Total	Integ	Total	Integ								
65	1750	19.26	17.72	3.62	24.88	22.89	3.77	30.79	28.26	3.91	37.20	33.74	4.06	44.98	39.41	4.26	51.96	51.96	4.43	60.02	60.02	4.64	69.62	69.62	4.91								
	1800	19.34	17.79	3.63	24.98	22.98	3.78	30.90	28.37	3.92	37.33	33.85	4.07	45.09	39.50	4.26	52.09	52.09	4.42	60.19	60.19	4.62	69.84	69.84	4.89								
	2250	20.06	18.45	3.75	25.74	23.69	3.88	31.75	29.14	4.00	38.31	34.75	4.12	45.93	40.25	4.28	53.12	53.12	4.41	61.48	61.48	4.58	71.51	71.51	4.81								
70	1750	18.37	16.90	3.77	24.01	22.09	3.92	30.00	27.54	4.08	36.36	32.98	4.24	44.47	38.96	4.46	51.32	51.32	4.63	59.22	59.22	4.85	68.63	68.63	5.12								
	1800	18.45	16.97	3.78	24.11	22.18	3.93	30.11	27.64	4.09	36.49	33.09	4.24	44.58	39.06	4.45	51.43	51.43	4.63	59.39	59.39	4.83	68.85	68.85	5.10								
	2250	19.15	17.62	3.90	24.92	22.93	4.04	30.96	28.41	4.17	37.44	33.95	4.30	45.42	39.80	4.47	52.45	52.45	4.61	60.65	60.65	4.79	70.47	70.47	5.02								
75	1750	17.44	16.04	3.93	23.12	21.27	4.09	29.18	26.78	4.26	35.57	32.26	4.43	43.08	37.74	4.63	50.66	50.66	4.85	58.44	58.44	5.07	67.67	67.67	5.35								
	1800	17.52	16.12	3.94	23.22	21.36	4.10	29.28	26.88	4.27	35.70	32.37	4.43	43.34	37.97	4.64	50.78	50.78	4.84	58.60	58.60	5.05	67.87	67.87	5.33								
	2250	18.19	16.73	4.06	23.99	22.07	4.21	30.13	27.65	4.35	36.62	33.21	4.48	44.87	39.31	4.68	51.79	51.79	4.82	59.83	59.83	5.00	69.45	69.45	5.24								

LEGEND

- BF – Bypass Factor
- edb – Entering Dry–Bulb
- Ewb – Entering Wet–Bulb
- kW – Total Unit Power Input
- SHC – Sensible Heat Capacity (1000 Btuh)
- TC – Total Capacity (1000 Btuh) (net)
- rh – Relative Humidity

COOLING NOTES:

1. Ratings are net; they account for the effects of the evaporator—fan motor power and heat.
2. Direct interpolation is permissible. Do not extrapolate.
3. The following formulas may be used:

$$t_{ldb} = t_{edb} - \frac{\text{Sensible capacity (Btuh)}}{1.10 \times \text{cfm}}$$

$$t_{lwb} = \text{Wet—bulb temperature corresponding to enthalpy air leaving evaporator coil (} t_{lwb} \text{)}$$

$$h_{lwb} = h_{ewb} - \frac{\text{total capacity (Btuh)}}{4.5 \times \text{cfm}}$$

Where: h_{ewb} = Enthalpy of air entering evaporator coil

4. The SHC is based on 80°F (26.7°C) edb temperature of air entering evaporator coil. Below 80°F (26.7°C) edb, subtract (corr factor x cfm) from SHC. Above 80°F (26.7°C) edb, add (corr factor x cfm) to SHC.

Correction Factor = $1.10 \times (1 + BF) \times (edb + 80)$.

5. Integrated capacity is maximum (instantaneous) capacity less the effect of frost on the outdoor coil and the heat required to defrost it.

6. The SHC is based on 80°F (26.7°C) edb temperature of air entering evaporator coil. Below 80°F (26.7°C) edb, subtract (corr factor x cfm) from SHC. Above 80°F (26.7°C) edb, add (corr factor x cfm) to SHC.

Correction Factor = $1.10 \times (1 + BF) \times (edb + 80)$.

7. Integrated capacity is maximum (instantaneous) capacity less the effect of frost on the outdoor coil and the heat required to defrost it.

UNIT	ELECTRICAL CHARACTERISTICS	UNIT WT.		UNIT HEIGHT IN/MM	CENTER OF GRAVITY IN/MM		
		LB.	KG.		X	Y	Z
24	208/230-1-60	320	145.0	41-15/16 [1055.2]	19-3/4 [501.7]	14-3/4 [371.7]	17-1/2 [444.5]
30	208/230-1-60	332	150.7	41-15/16 [1055.2]	19-3/4 [501.7]	14-3/4 [371.7]	17-7/8 [454.0]
36	208/230-1-60	338	152.3	41-15/16 [1055.2]	19-3/4 [501.7]	14-3/4 [371.7]	18 [457.2]

REQUIRED CLEARANCES TO COMBUSTIBLE MATL.

UNITS	CORNER WEIGHT LB/KG	
	"1"	"4"
24	64.0 [29.0]	51.2 [23.2]
30	66.5 [30.2]	53.2 [24.1]
36	67.2 [30.5]	53.7 [24.4]

INCHES [MM]
 TOP OF UNIT.....14 [355.6]
 BOTTOM OF UNIT.....0 [0.0]
 ELECTRICAL PANEL.....36 [914.4]

INCHES [MM]
 BETWEEN UNITS, POWER ENTRY SIDE.....42 [1066.8]
 UNIT AND UNGROUNDED SURFACES, POWER ENTRY SIDE.....36 [914.0]
 UNIT AND BLOCK OR CONCRETE WALLS AND OTHER GROUNDED SURFACES, POWER ENTRY SIDE.....42 [1066.8]

REQUIRED CLEARANCE FOR OPERATION AND SERVICING

INCHES [MM]
 EVAP. COIL ACCESS SIDE.....36 [914.0]
 POWER ENTRY SIDE.....42 [1066.8]
 UNIT TOP FOR NEC REQUIREMENTS.....48 [1219.2]
 SIDE OPPOSITE DUCTS.....36 [914.0]
 DUCT PANEL.....12 [304.8]

*MINIMUM DISTANCES IF UNIT IS PLACED LESS THAN 12 [304.8] FROM WALL SYSTEM, THEN SYSTEM PERFORMANCE MAYBE COMPROMISED.

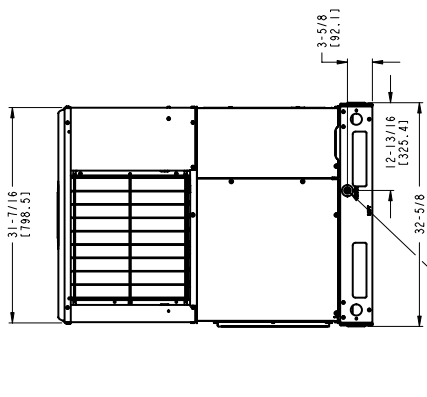
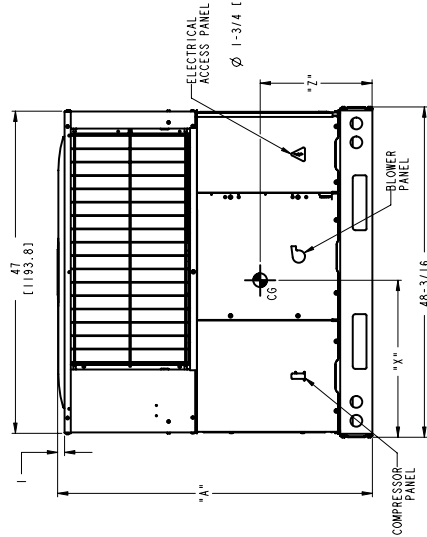
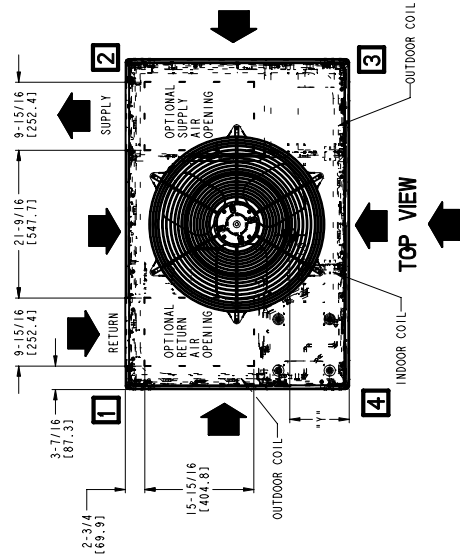

DIMENSIONS IN [] ARE IN MM

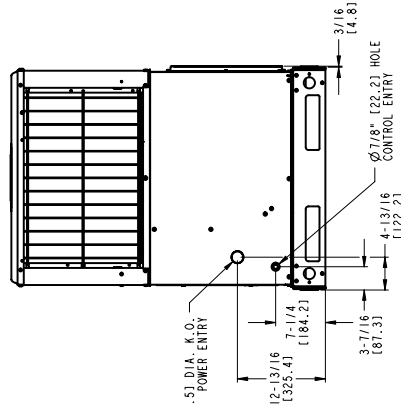
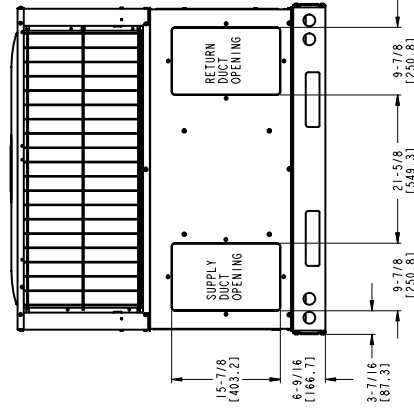

FRONT VIEW

LEFT SIDE VIEW

RIGHT SIDE VIEW

REAR VIEW

50EZ500357 2.0

CONNECTION WIRING DIAGRAM

DANGER: ELECTRICAL SHOCK HAZARD DISCONNECT POWER BEFORE SERVICING

SCHEMATIC
208/230-1-60

- NOTES:
- IF ANY OF THE ORIGINAL WIRES FURNISHED ARE REPLACED, THEY MUST BE REPLACED WITH THE SAME WIRE OR ITS EQUIVALENT.
 - USE 75 DEG. COPPER CONDUCTORS FOR FIELD INSTALLATION.
 - SEE INSTALLATION INSTRUCTIONS FOR PROPER HEATING AND COOLING CONNECTIONS FOR YOUR UNIT. INDOOR FAN MOTOR PLUGS - "DO NOT DISCONNECT UNDER LOAD"
 - CCH NOT USED ON ALL UNITS.
 - THIS FUSE IS MANUFACTURED BY LITTELFUSE, P/N 257003.
 - UNIT FACTORY-SHIPED IN STD MODE.

LEGEND

- | | | | |
|-------|--|--------|----------------------------|
| △ | FIELD SPLICE | COMP | COMPRESSOR MOTOR |
| ○ | TERMINAL (MARKED) | DB | DEFROST BOARD |
| ○ | TERMINAL (UNMARKED) | DEHUM | DEHUMIDIFICATION MODE |
| ● | SPLICE | DFT | DEFROST TEMPERATURE SWITCH |
| ○ | SPLICE (MARKED) | DR | DEFROST RELAY |
| --- | FACTORY WIRING | EQUIP | EQUIPMENT |
| --- | FIELD CONTROL WIRING | GND | GROUND |
| --- | FIELD POWER WIRING | HPS | HIGH PRESSURE SWITCH |
| --- | ACCESSORY OR OPTIONAL WIRING | HR | HEATER RELAY |
| --- | TO INDICATE COMMON POTENTIAL ONLY; NOT TO REPRESENT WIRING | IFB | INDOOR FAN BOARD |
| C | CONTACTOR | IFM | INDOOR FAN MOTOR |
| CAP 1 | CAPACITOR, COMP | LPS | LOW PRESSURE SWITCH |
| CCH | CRANK CASE HEATER | OFM | OUTDOOR FAN MOTOR |
| | | RVS | REVERSING VALVE |
| | | STD | STANDARD MODE |
| | | TRAN | TRANSFORMER |
| | | T-STAT | THERMOSTAT |

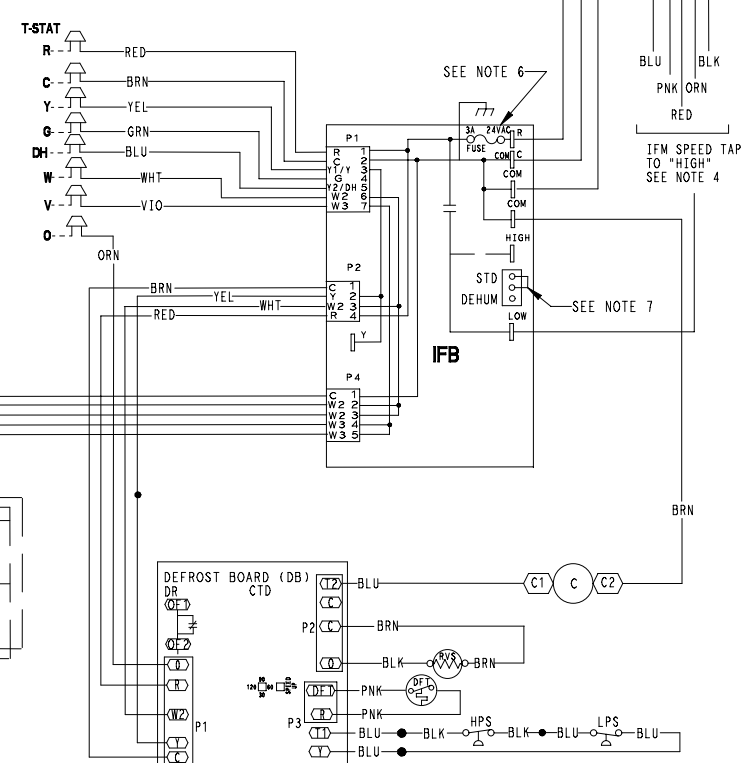
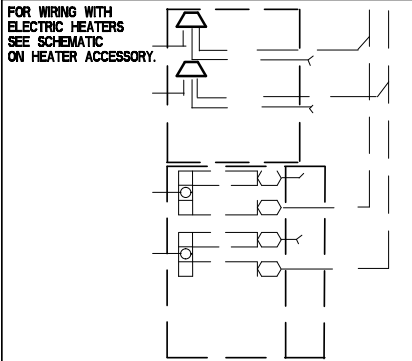
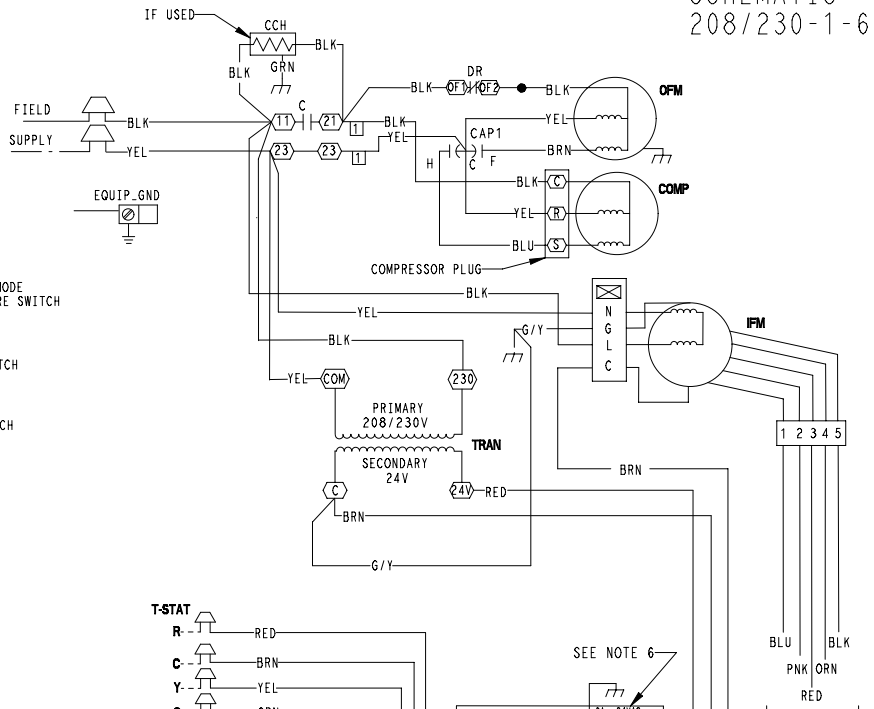

- COLOR CODE
- | | |
|-----|--------|
| BLK | BLACK |
| BLU | BLUE |
| BRN | BROWN |
| GRY | GRAY |
| GRN | GREEN |
| ORN | ORANGE |
| PNK | PINK |
| RED | RED |
| VIO | VIOLET |
| WHT | WHITE |
| YEL | YELLOW |

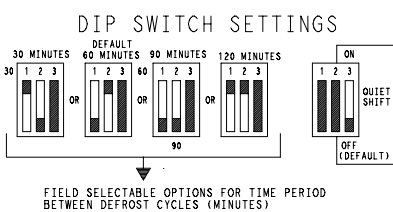
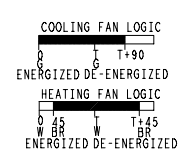

- SPEED UP JUMPERED TEST PINS (USE METAL OBJECT) FIELD SPEED-UP CYCLE
- MOMENTARILY SHORT PINS AND RELEASE TO BYPASS COMPRESSOR OFF DELAY.
 - SHORT FOR 5+ SEC. AND RELEASE FOR FORCED DEFROST.
 - PERMANENT SHORT WILL BE IGNORED.
- DEFROST WILL TERMINATE IN 30 SEC. IF DFT OPEN. DEFROST WILL TERMINATE NORMALLY IF DFT IS CLOSED.
- THE COMPRESSOR WILL SHUT OFF FOR 30 SEC. ON DEFROST INITIATION AND TERMINATION IN THE "QUIET SHIFT" ON POSITION

LADDER WIRING DIAGRAM

DANGER: ELECTRICAL SHOCK HAZARD DISCONNECT POWER BEFORE SERVICING

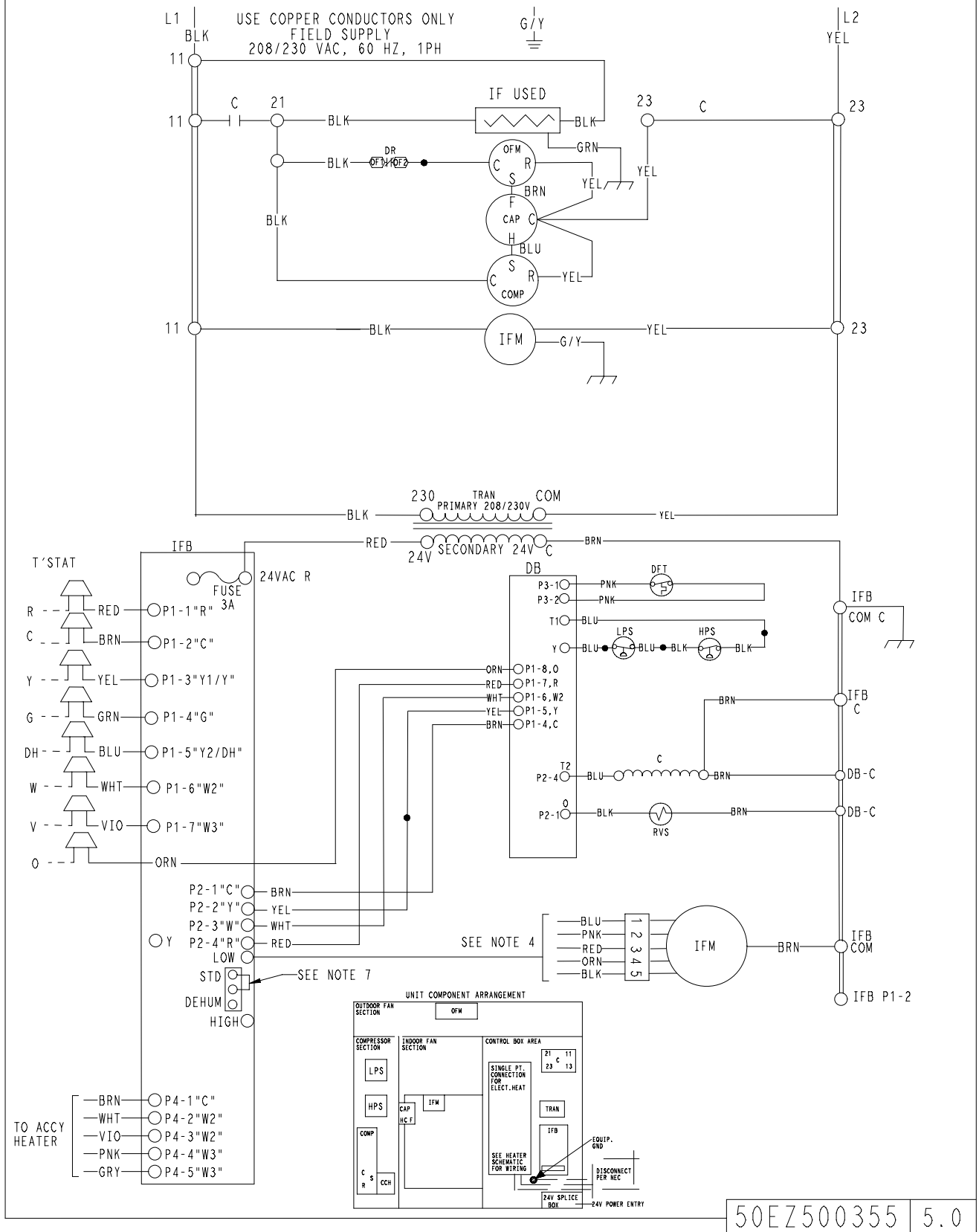

CONTROLS

Operating sequence

When power is supplied to unit, the transformer (TRAN) is energized.

On units with crankcase heater, heater is also energized.

Cooling — With the thermostat in the cooling position, the thermostat makes circuit “R” to “O”. This energizes the reversing valve solenoid (RVS) and places the unit in standby condition for cooling.

As the space temperature rises, the thermostat closes circuit “R” to “Y”. A circuit is made to contactor (C), starting the compressor (COMP) and outdoor-fan motor (OFM). Circuit “R” to “G” is made at the same time and starts the indoor-fan motor (IFM).

When the thermostat is satisfied, contacts open, deenergizing C. The COMP and OFM stop, and the IFM stops after the preselected time delay.

On the loss of the thermostat call for cooling, 24 V is removed from both the “Y1/Y” and “G” terminals (provided the fan switch is in the “AUTO” position) de-energizing the compressor contactor and opening the contacts supplying power to compressor/OFM. After a 90-second delay, the IFM shuts off. If the thermostat fan selector switch is in the “ON” position, the IFM will run continuously.

Heating — On a call for heat, thermostat makes circuits “R” to “Y” and “R” to “G”.

A circuit is made to C, starting COMP and OFM. Circuit “R” to “G” also is completed, energizing IFR and starting IFM after the selected time delay.

Should room temperature continue to fall, circuit “R” to “W” is made through second-stage thermostat. If optional electric heat package is used, a relay is energized, bringing on first bank of supplemental electric heat. When thermostat is satisfied, contacts open, deenergizing contactor and relay; motors and heaters deenergize.

ROOF CURBS

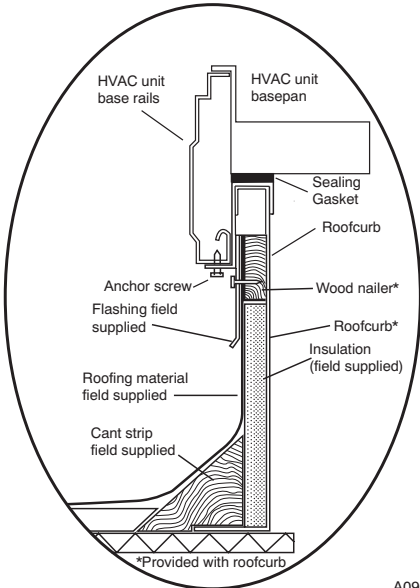

ROOF CURB DETAIL

A09090

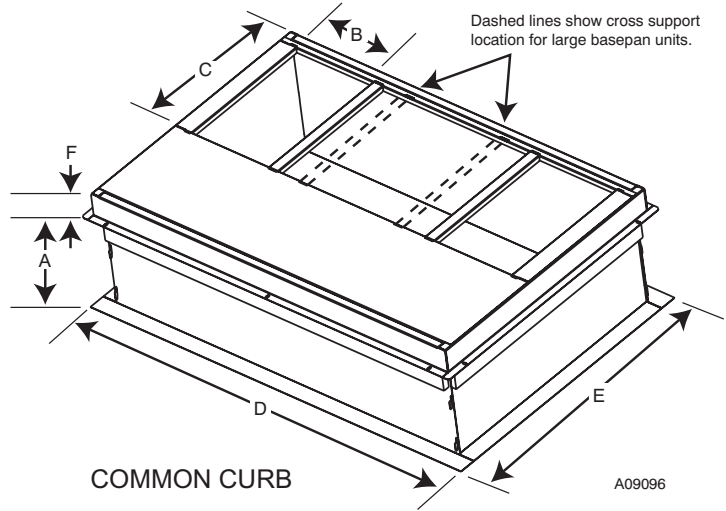

COMMON CURB

A09096

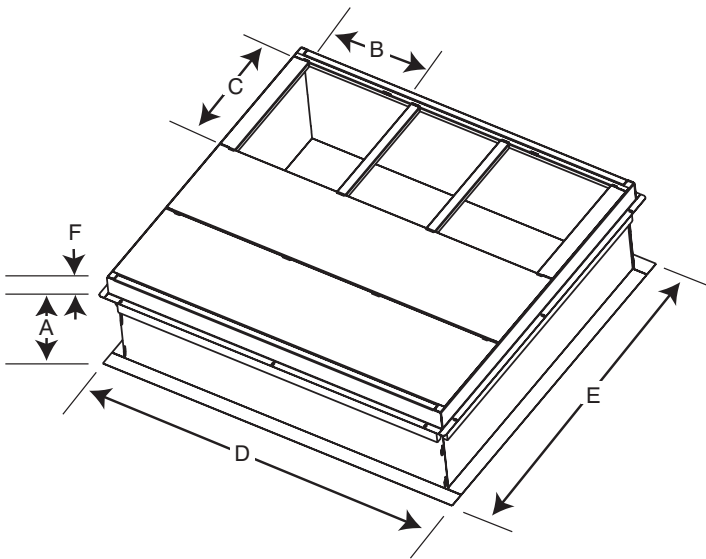

LARGE CURB

A09095

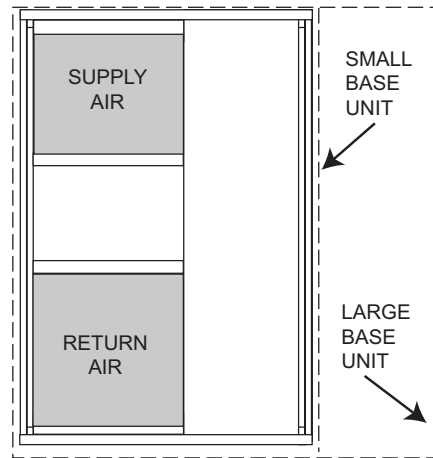

UNIT PLACEMENT ON COMMON CURB

A09094

SMALL OR LARGE BASE UNIT

UNIT SIZE	CATALOG NUMBER	A IN. (mm)	B (small base) IN. (mm)*	B (large base) IN. (mm)*	C IN. (mm)	D IN. (mm)	E IN. (mm)	F IN. (mm)
Small or Large	CPRFCURB010A00	11 (279)	10 (254)	14 (356)	16 (406)	47.8 (1214)	32.4 (822)	2.7 (69)
	CPRFCURB011A00	14 (356)						
Large	CPRFCURB012A00	11 (279)	N/A				43.9 (1116)	
	CPRFCURB013A00	14 (356)						

* Part Numbers CPRFCURB010A00 and CPRFCURB011A00 can be used on both small and large basepan units. The cross supports must be located based on whether the unit is a small basepan or a large basepan.

NOTES:

1. Roof curb must be set up for unit being installed.
2. Seal strip must be applied, as required, to unit being installed.
3. Roof curb is made of 16-gauge steel.
4. Attach ductwork to curb (flanges of duct rest on curb).
5. Insulated panels: 1-in. (25.4 mm) thick fiberglass 1 lb. density.

PHD3 ACCESSORIES (continued)

Accessory Model Number	Description	Use With Model Size			
ROOF CURBS					
CPRFCURB010A00	Roof Curb, 11" High	24 – 60			
CPRFCURB011A00	Roof Curb, 14" High	24 – 60			
CPRFCURB012A00	Roof Curb, 11" High	42 – 60			
CPRFCURB013A00	Roof Curb, 14" High	42 – 60			
Note: CPRFCURB010A00 AND CPRFCURB011A00 can be used with 42–60 size units with some overhang.					
ADAPTER CURBS*					
CPADCURB001A00	Adapter curb for use with NPRFCURB006A00 & NPRFCURB007A00	24 – 36			
CPADCURB002A00	Adapter curb for use with NPRFCURB008A00 & NPRFCURB009A00	42 – 60			
* Can also be used when replacing other manufacturer's older generation units that contain a composite base without a metal base rail.					
CONCENTRIC ADAPTERS – (Use with curb only)					
NPCONADP001A00	For 18" round duct (use with curbs CPRFCURB010A00, CPRFCURB011A00)	Small Curb			
NPCONADP002A00	For 18" round duct (use with curbs CPRFCURB012A00, CPRFCURB013A00)	Large Curb			
CONCENTRIC DIFFUSERS – (Ceiling or under roof)					
AXB020CSA*	Step Down Diffuser – Fits 2' x 4' Ceiling Grid (16" round collars for flex conn.)	24 – 42			
AXB020CFA*	Flush Mount Diffuser – Fits 2' x 4' Ceiling Grid (16" round collars for flex conn.)	24 – 42			
AXB030CSA	Step Down Diffuser – Fits 2' x 4' Ceiling Grid (18" round collars for flex conn.)	24 – 60			
AXB030CFA	Flush Mount Diffuser – Fits 2' x 4' Ceiling Grid (18" round collars for flex conn.)	24 – 60			
* A field supplied 18" to 16" round reducer required when used with NP concentric adaptor					
ECONOMIZERS					
CPECOMZR007A00	Dedicated Vertical Economizer – Internal with solid state controller, gear driven, fully modulating damper, spring return actuator, up to 50% barometric relief, supply and dry bulb outdoor air sensors. Includes filter rack with 1" filters*.	24 – 36			
CPECOMZR008A00		42, 48			
CPECOMZR009A00		60			
CPECOMZR010A00	Dedicated Horizontal Economizer – Internal with solid state controller, fully modulating damper, spring return actuator, supply and dry bulb outdoor air sensor, and low ambient compressor lockout switch included. Includes filter rack with 1-inch filters*.	24 – 36			
CPECOMZR011A00		42, 48			
CPECOMZR012A00		60			
CPRLYKIT001A00	Economizer relay for heat pumps	ALL			
AXB078ENT	Outdoor Enthalpy Control	ALL			
* Outdoor enthalpy available as field installed accessory; Filter rack and 1" filter, same as CPFILTRK kit					
MANUAL FRESH AIR DAMPERS					
CPMANDPR007A00	Manual Outside Air Damper – (Includes filter rack and 1" filter, same as CPFILTRK kit)	24 – 36			
CPMANDPR008A00		42, 48			
CPMANDPR009A00		60			
INTERNAL FILTER RACK and FILTER (shipped with 1" filters)					
CPFILTRK007A00	Internal Filter Rack	24 – 36			
CPFILTRK008A00		42, 48			
CPFILTRK009A00		60			
LOW AMBIENT, ANTI-CYCLE TIMER, COMPRESSOR START ASSIST					
CPLOWAMB001A00	Low Ambient Control – enables cooling system to operate down to 0 Deg. F by cycling condenser fan on and off.	ALL			
NRTIMEGD001A00	Five Minute Compressor Delay	ALL			
CPHSTART002A00	PTC Compressor Start Assist	ALL			
CRANKCASE HEATER – BELLY BAND TYPE					
NPCRKHTR008A00	240V Crankcase Heater (included on 30 size)	24, 36			
NPCRKHTR004A00	240V Crankcase Heater (included on 60 size)	48			
HAIL GUARDS / COIL PROTECTION (Factory installed on PHD3**000KTP models)					
NAPA00501GR	3/8" spacing dense wire grilles	24 – 36			
NAPA00601GR	3/8" spacing dense wire grilles	42 – 48			
NAPA01001GR	3/8" spacing dense wire grilles	60			
ELECTRIC HEATERS					
208/240V					
PART NO.	NOMINAL CAPACITY (kW)	FUSED	# FUSES	STAGES	USE WITH
EHNA05K0N	3.8 / 5.0	NO	0	1	24 – 36
EHNA05K4F	3.8 / 5.0	YES	4	1	ALL
EHNA07K4F	5.4 / 7.2	YES	4	2	ALL
EHNA10K4F	7.5 / 10.0	YES	4	2	ALL
EHNA15K6F	11.3 / 15.0	YES	6	2	30 – 60
EHNA20K6F	15.0 / 20.0	YES	6	2	42 – 60
DUAL POINT WIRING KIT					
CPDUALPT001A00	Dual Point Wiring kit, 5–20kW Heaters				ALL
DUCT TRANSITIONS					
NPDU CFLG002A00	Square to Round (1 set of 2, use with horizontal duct flanges only)				24 – 48

International Comfort Products, LLC
 Lewisburg, Tennessee 37091 USA
 www.GoHeil.com