

## Model E101 Food Waste Disposer

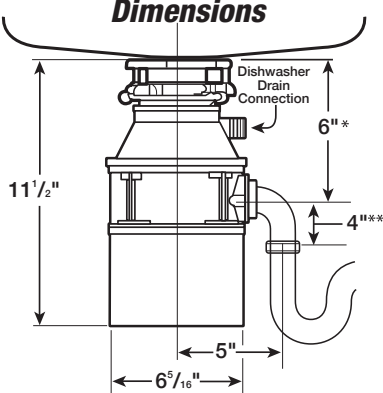

### Dimensions



\* Distance from bottom of sink to center line of disposer outlet. Add 1/2" when stainless steel sinks are used.

\*\* Length of tailpipe from center line of disposer outlet to end of tailpipe.

NOTE: Plumb waste line to prevent standing water in disposer motor housing.

### Submittal Sheet

- 1/3 Horsepower Motor
- 1 year parts and in-home service warranty†
- Quick Lock<sup>®</sup> mounting for fast, easy installation
- Galvanized steel grinding elements with two stainless steel 360° swivel lugs
- Stainless steel sink flange with positive seal plastic stopper
- Overload protector manual reset
- Permanently lubricated upper and lower bearings
- Cushioned anti-splash baffle
- Dishwasher drain connection
- Exclusive self-service wrench

### Sample Specification

Food Waste Disposer(s) shall be Evergrind™ Model E101, continuous feed, with 1/3 H.P. motor, galvanized steel grinding elements with two stainless steel 360° swivel lugs. Self-service wrench

Available with or without 3' factory installed power cord

Warranty - 1 year parts and in-home service.

† The complete Evergrind™ warranty is included in the Care & Use Booklet, packed with each unit.

### Specifications

|                              |  |
|------------------------------|--|
| Type of Feed                 | Continuous                                     |
| On/Off Control               | Wall Switch                                    |
| Motor                        | Single Phase                                   |
| HP                           | 1/3  |
| Volts                        | 120  |
| HZ                           | 60   |
| RPM                          | 1725   |
| Amp. (Avg. Load)             | 5.7  |
| Time Rating                  | Intermittent                                   |
| Lubrication                  | Permanently Lubricated Upper & Lower Bearings  |
| Shipping Weight (Approx.)    | Without Cord: 12lbs 10oz<br>Corded: 12lbs 14oz |
| Unit Finish                  | Waterborne Grey Enamel                         |
| Overall Height               | 11-1/2"  |
| Grind Chamber Capacity       | 26 oz.   |
| Motor Protection             | Manual Reset Overload                          |
| Average Water Usage          | Approx. 1 Gallon per Person Per Day            |
| Average Electrical Usage     | 3-4 KWh per Year                               |
| Drain Connection             | 1-1/2" Cushioned Slip Joint                    |
| Dishwasher Drain Connection  | Yes  |
| Factory Installed Power Cord | Available with or without                      |

### Job Specifications

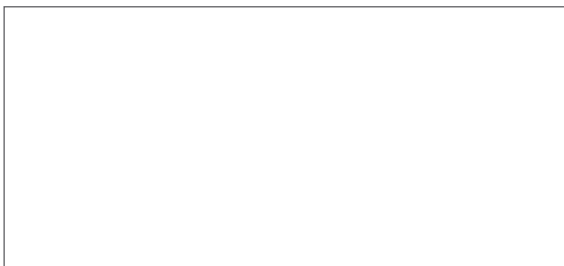

Food waste disposers can provide an environmentally responsible alternative to transporting food waste to landfills. And they can help reduce greenhouse gas emissions. At capable wastewater treatment plants, food waste can be recycled to produce renewable energy. Additionally, capable wastewater treatment plants can process food waste into fertilizer. (Check the plant in your area.)

[www.insinkerator.com/green](http://www.insinkerator.com/green)

