

Product information presented here reflects conditions at time of publication. Consult factory regarding discrepancies or inconsistencies.

PUMP COMPANY

Zoeller Family of Water Solutions™

MAIL TO: P.O. BOX 16347 • Louisville, KY 40256-0347
 SHIP TO: 3649 Cane Run Road • Louisville, KY 40211-1961
 (502) 778-2731 • 1 (800) 928-PUMP • FAX (502) 774-3624

visit our web site:
www.zoeller.com



THE ZOELLER Oil Guard® SYSTEM

FOR SUBMERSIBLE DEWATERING APPLICATIONS

APPLICATIONS:

Designed to help protect the environment and equipment from the dispersion of oils and/or hydrocarbons.

- Elevator Sumps
- Transformer Vaults
- Manufacturing Facilities

SYSTEMS:

- Operation of the Zoeller Oil Guard® System has been independently verified by OnSpeX, div. of CSA, when installed in accordance with our instructions.
- Choose from four model pumps. Includes pump, Oil Smart® switch and alarm (optional control panel).
- Control systems are ASME A17.1 compliant.

Oil Smart® SWITCH AND ALARM PANEL FEATURES:

- NEMA-4X alarm panel enclosure
- Audible, light alarms and dry contacts
- Preset "on" and "off" points differentiate oil and water and alerts maintenance personnel of high water or oil detected conditions
- 20 ft. piggyback electrical supply cord
- 20 amp internal relay
- Alarm test and silence switches
- 304 stainless steel probes
- UL508 approved switch

PUMP FEATURES:

- Pumps are durable cast iron construction with powder coated epoxy finish and all stainless steel fittings. See back page for a list of pump catalog sheets
- Tested to UL Standard UL778 and Certified to CSA Standard CSA 22.2 No. 108



Model 940-0011 shown. Product may not be exactly as shown.

SIMPLEX PANEL FEATURES:

- Oil Smart® liquid alarm switch
- Oil Smart® pump switch (10-2282)
- 115 volts, single phase
- NEMA 4X watertight enclosure with lockable latch
- 30 amp motor start relay
- Pump HOA switch
- Top-mounted red alarm beacon light
- 81 - 84 decibel rated alarm horn
- Horn silence and alarm test switches
- Alarm automatically resets
- Dry auxiliary alarm contacts
- Separate circuit protection for alarm
- Circuit breaker protection
- Pump "Run" indicator light



Model 10-2149



DUPLEX ALTERNATING PANEL FEATURES:

- Oil Smart® liquid alarm switch
- Oil Smart® pump switch (10-2283)
- Oil Smart® high water alarm switch for high demand two pump operation
- 115 volts, single phase
- NEMA 4X watertight enclosure with lockable latch
- Two 30 amp motor start relays
- Pump HOA switches
- Top mounted red alarm beacon light
- 81 - 84 decibel rated alarm horn
- Horn silence and alarm test switches
- Alarm automatically resets
- Dry auxiliary alarm contacts
- Separate circuit protection for alarm
- Pump "Run" indicator light



Model 10-2150



**TOTAL DYNAMIC HEAD/FLOW PER MINUTE
EFFLUENT AND DEWATERING**

MODEL		57		152		153		161	
Feet	Meters	Gal.	Liters	Gal.	Liters	Gal.	Liters	Gal.	Liters
5	1.5	43	163	69	261	77	291	100	379
10	3.0	34	129	61	231	70	265	93	352
15	4.6	19	72	53	201	61	231	85	322
20	6.1	--	--	44	167	52	197	79	299
25	7.6	--	--	34	129	42	159	70	265
30	9.1	--	--	23	87	33	125	62	235
35	10.7	--	--	--	--	22	83	54	204
40	12.2	--	--	--	--	11	42	45	170
50	15.2	--	--	--	--	--	--	20	76
Shut-off Head:		19.25 ft (5.9 m)		38 ft (11.6 m)		44 ft (13.4 m)		56 ft (17 m)	

018939

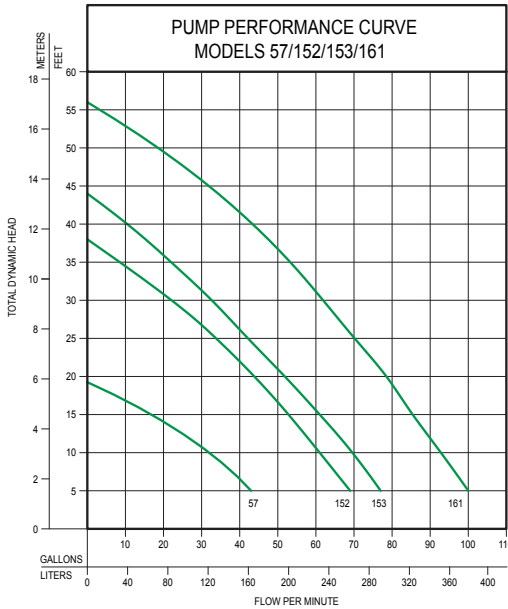

Model 57

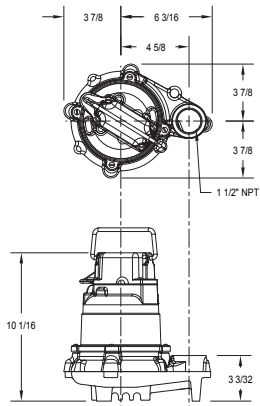

(See FM0493)

Model 152/153

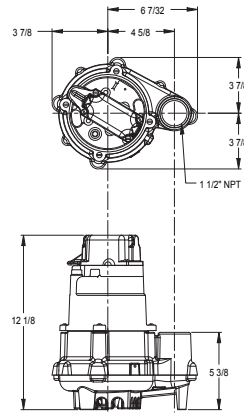

(See FM1919)

Model 161

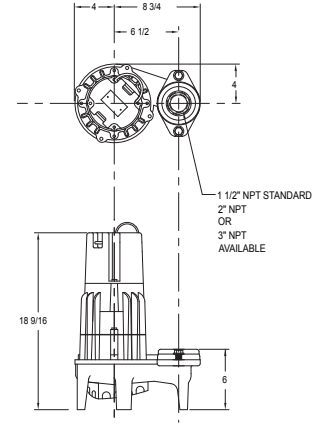

(See FM0460)

COMPONENTS:

Part Number	Description	Alarm Panel	Oil Smart® Pump Switch	Oil Smart® High Liquid Alarm Switch	Oil Smart® High Liquid Switch
10-1526	Oil Smart® Alarm Panel	✓	---	✓	---
10-1528	Oil Smart® Pump Switch	---	✓	---	---
10-1727	Oil Smart® Pump Switch w/o Plug	---	✓	---	---
10-2149	Oil Smart® Simplex Panel	✓	✓	✓	---
10-2150	Oil Smart® Duplex Panel	✓	✓	✓	✓
10-2516	Oil Smart® Simplex Panel w/ Mtr. Cont.	✓	✓	*	---

These systems are not designed for Explosion Proof Environments. Please consult factory for special options and requirements.

CAUTION

All installation of controls, protection devices and wiring should be done by a qualified licensed electrician. All electrical and safety codes should be followed including the most recent National Electrical Code (NEC) and the Occupational Safety and Health Act (OSHA).

✓ INCLUDED * VARIABLE LEVEL FLOAT SWITCH

CHOOSE A PREPACKAGED SYSTEM:

Part Number	Description	Alarm Panel	Oil Smart® Pump Switch	Nonauto Pump	Pump Part Number	Voltage	HP	Amps	Elevator System
940-0005	Oil Guard® Pump Switch and Panel	10-1526	10-1528	N57	57-0002	115	3/10	9.7	---
940-0006	Oil Guard® Pump Switch and Panel	10-1526	10-1528	N152	152-0002	115	4/10	8.5	---
940-0007	Oil Guard® Pump Switch and Panel	10-1526	10-1528	N153	153-0002	115	1/2	10.5	---
940-0008	Oil Guard® Pump Switch and Panel	10-1526	10-1528	N161	161-0002	115	1/2	15.0	---
940-0012	Oil Guard® Pump Switch and Panel	10-1526	10-1528	*N152	*152-0028	115	4/10	8.5	✓
940-0013	Oil Guard® Pump Switch and Panel	10-1526	10-1528	*N153	*153-0027	115	1/2	10.5	✓
940-0014	Oil Guard® Pump Switch and Panel	10-1526	10-1528	*N161	*161-0090	115	1/2	15.0	✓

* 6' SO JACKETED CORD FOR OIL-RESISTANCE

NOTE: BUILD YOUR OWN SYSTEM. CONTACT FACTORY FOR SPECIFICATIONS.