

## SPECIFICATIONS

# FIGURE X420A

## BRASS BODY BALL VALVES



### LOW LEAD COMPLIANT 2-PC FULL PORT 600 WOG

#### FEATURES

- 600 WOG
- 150 WSP
- Full port
- NSF 61 Annex G certified (UL) (Annex G references NSF 372)
- Meets MSS SP-110 standards
- Blow-out proof stem
- Adjustable packing
- Threaded NPT ends per ANSI B 1.20.1
- 100% electronically tested in open and closed position at 80 PSI
- Optional lock lever
- Optional stem extension
- Optional tee handle (to 1")
- Optional oval handle
- Optional memory stop



NOT FOR USE AT OR BELOW GROUND LEVEL

Low Lead Compliant: Referring to laws defining "Lead Free" as wetted surface of pipe, fittings and fixtures in potable water systems that have a weighted average lead content  $\leq 0.25\%$  per the Safe Drinking Water Act (Sec. 1417) amended 1-4-2011 as well as other state regulations.

#### Gas Approvals

- CSA Class 3371-10, CGA 3.16, 125 PSIG, -40°F–149°F (1/4"–2")
- CSA Class 3371-88, ANSI Z21.15/CSA9.1, 1/2 PSIG, 32°F–188.6°F (1/2"–2")
- CSA Class 3371-90, ASME B16.33/b16.38, 125 PSIG, -40°F–149°F (1/4"–2")
- CSA Class 3371-92, ASME B16.44, 5 PSIG, -40°F–149°F (1/2"–2")
- CSA Class 3371-94, ASME B16.33, 125 PSIG, -40°F–149°F (1/2"–2")
- CSA Class 3371-97, UL-125, 250 PSIG, -40°F–130°F (1/4"–3/8")
- UL Class YRPV, ANSI/UL-842, 250 PSIG, -20°F–125°F (1/4"–2")
- UL Class YSDT, ANSI/UL-125, 250 PSIG, -40°F–130°F (1/4"–2")

#### ACCESSORIES/OPTIONS



Lock Lever



Stem Extension



Tee or Oval Handle



Memory Stop

# SPECIFICATIONS

## FIGURE X420A BRASS BODY BALL VALVES



### LOW LEAD COMPLIANT 2-PC FULL PORT 600 WOG

#### CV & WEIGHTS

Size (in.)	CV	Wt (lbs)
1/2	19	0.48
3/4	34	0.79
1	50	1.22
1-1/4	103	2.14
1-1/2	266	3.20
2	307	4.08

#### FIGURE NUMBER MATRIX

FNW X420A	
SIZE CODE (IN.)	
1/2 = D	1-1/4 = H
3/4 = F	1-1/2 = J
1 = G	2 = K

#### KIT CODES

FNW 420	
KIT TYPE	SIZE (IN.)
Locking Handle = LHK	1/4-1/2 = BD
Stem Extension = SE	3/4-1 = FG
Tee Handle = THK	1-1/4-1-1/2 = HJ
Oval Handle = OHK	2 = K
Memory Stop = MSK	
Stainless Handle = SSHK	

Note: Figure X420A uses the same accessories as Figure 420.

#### REFERENCE CHART

Item #	Size (in.)	Dimensions (in.)				
		ØD	E	H	L	L1
FNWX420AD	1/2	0.59	3.86	1.81	2.44	0.50
FNWX420AF	3/4	0.79	4.80	2.28	2.71	0.75
FNWX420AG	1	0.98	4.80	2.44	3.07	0.91
FNWX420AH	1-1/4	1.26	6.02	3.00	3.42	0.96
FNWX420AJ	1-1/2	1.57	6.02	3.23	3.89	1.10
FNWX420AK	2	1.95	6.38	3.74	4.33	1.34

PARTS BREAKDOWN

**FIGURE X420A**  
BRASS BODY BALL VALVES



LOW LEAD COMPLIANT 2-PC FULL PORT 600 WOG

PARTS DIAGRAM

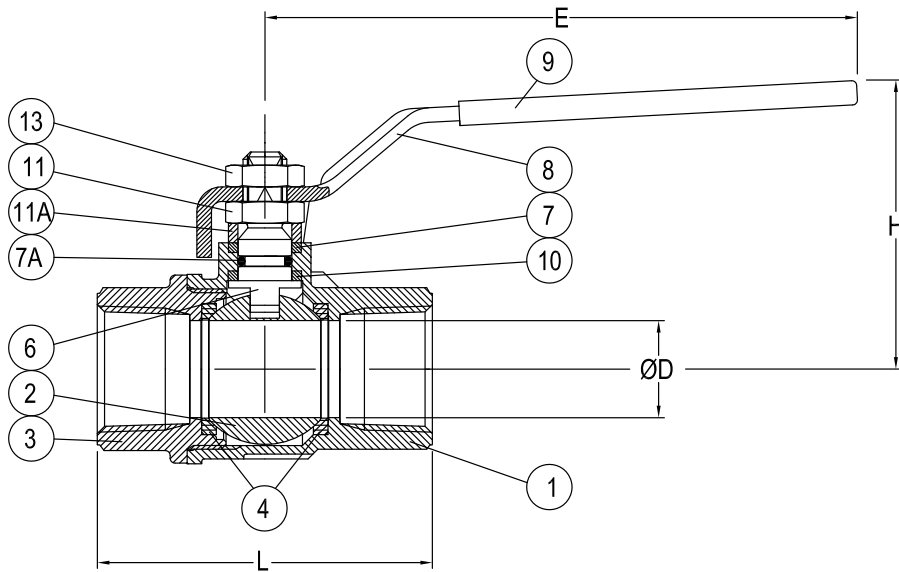

PART MATERIALS & QUANTITY

Ref #	Description	Material	Qty
1	Body	Brass CW 510L	1
2	Ball	Brass CW 510L (Chrome-Plated)	1
3	End Cap	Brass CW 510L	1
4	Seat	PTFE	2
6	Stem	Brass CW 510L	1
7	Stem Packing	PTFE	1 Set
7A	Stem O-Ring	NBR 75 Shore A	1
8	Handle	Steel DD11	1
9	Sleeve	Vinyl	1
10	Thrust Washer	PTFE	1
11	Gland Nut	Steel CL 04	1
11A	Packing Gland	Brass CW 614N UNI 12164	1
13	Handle Nut	Steel CL 04	1