

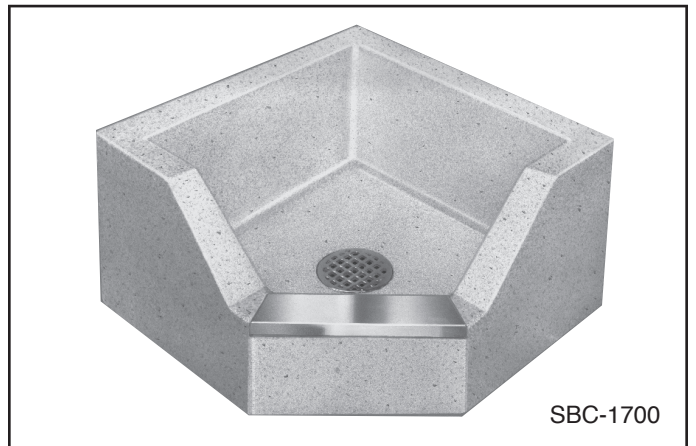

HiLow®



CORLOW®



STERN
WILLIAMS
HiLow® CORLOW®
 MOP SERVICE BASINS
ARCHITECTURAL SPECIFICATIONS

6" FRONT DROP WITH STAINLESS STEEL CAP

MODEL	SIZE
HL-1800	24"x24"x12"
HL-1900	32"x32"x12"
HL-2000	36"x36"x12"
HL-2100	36"x24"x12"

6" FRONT DROP WITH STAINLESS STEEL CAP ALL SIDES

MODEL	SIZE
HL-1810	24"x24"x12"
HL-1910	32"x32"x12"
HL-2010	36"x36"x12"
HL-2110	36"x24"x12"

6" FRONT DROP WITH STAINLESS STEEL CAP

MODEL	SIZE
SBC-1700	24"x24"x12"
SBC-1702*	24"x24"x12"
SBC-1725	32"x32"x12"
SBC-1750	36"x36"x12"

*NOTE: 2 tiling flanges extending 1" above shoulder on 2 sides.

Model No. () Size (), as manufactured by Stern-Williams Co., Inc. Shoulders shall not be less than 9-3/4" high inside measurement, and not less than 1-1/4" wide. All models have 6" drop at threshold. Drain shall be cast brass with stainless steel strainer cast integral and shall provide for a caulked lead connection not less than 1" deep to a 3" pipe. Receptor composed of pearl gray marble chips and white Portland cement ground smooth, grouted and sealed to resist stains. Stainless steel cap of one piece 20 ga. 302 stainless steel cast integral on threshold.

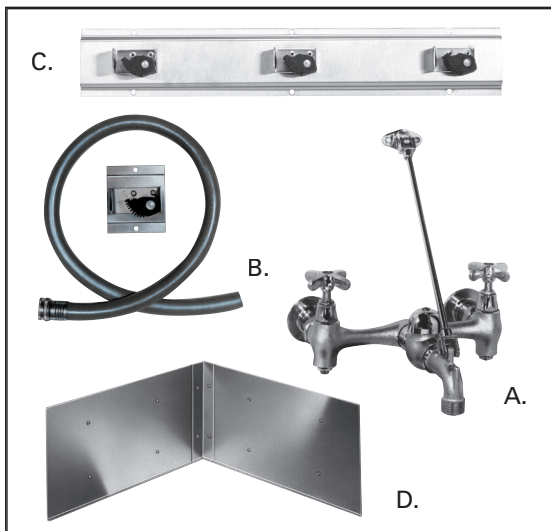

QUALITY OPTIONAL FITTINGS

- A. **T-10-VB** Mop-Service sink fitting with vacuum breaker, adjustable top brace, 3/4" hose thread on spout with bucket hook inlets 8" on center, chrome finish.
T-15 VB same as above with polished chrome finish.
- B. **T-35** Hose and wall hook. Hose 36" long, with 3/4" chrome couplings. Wall bracket of stainless steel.
- C. **T-40** Stainless Steel Mop Hanger of stainless steel with #4 finish. . . 24" long, with 3 rubber spring loaded grips.
- D. **BP** Splash Catcher Panels of 20 ga. type 304 stainless steel.

JOB

ARCHITECT

LOCATION

ENGINEER

CROSS SECTION SERIES 1700

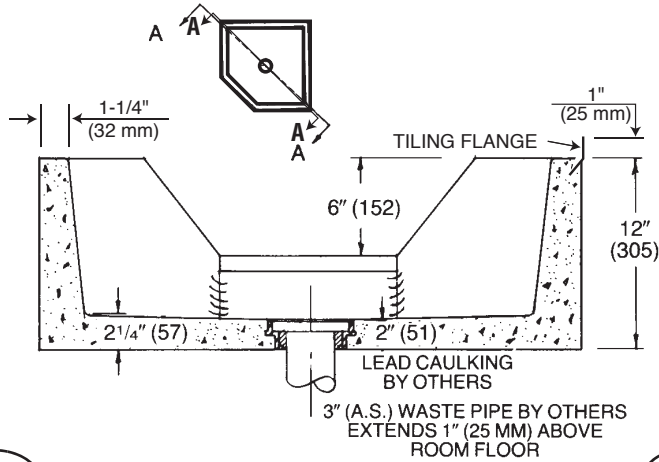

CROSS SECTION SERIES 1800, 1900, 2000, 2100

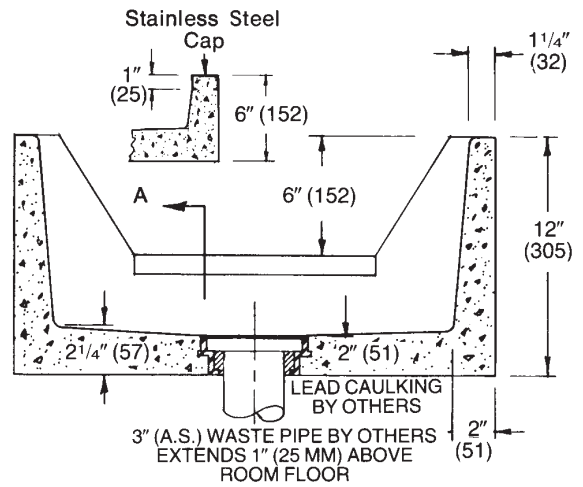

ROUGH-IN SERIES 1800, 1900, 2000, 2100

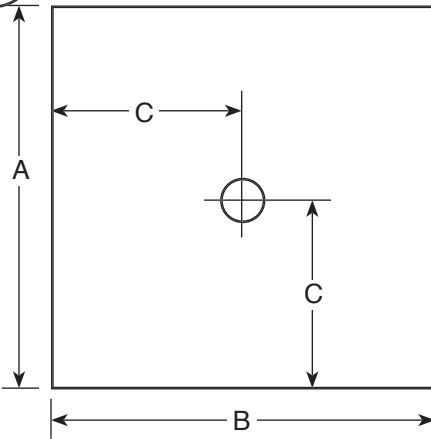

MODEL	A		B		C	
	IN	MM	IN	MM	IN	MM
1800	24	610	24	610	12	305
1900	32	813	32	813	16	406
2000	36	915	36	915	18	457

MODEL	A		B		C	
	IN	MM	IN	MM	IN	MM
1810	24	610	24	610	12	305
1910	32	813	32	813	16	406
2010	36	915	36	915	18	457

MODEL	A		B		C		D	
	IN	MM	IN	MM	IN	MM	IN	MM
2100	24	610	36	915	12	305	18	457
2110	24	610	36	915	12	305	18	457

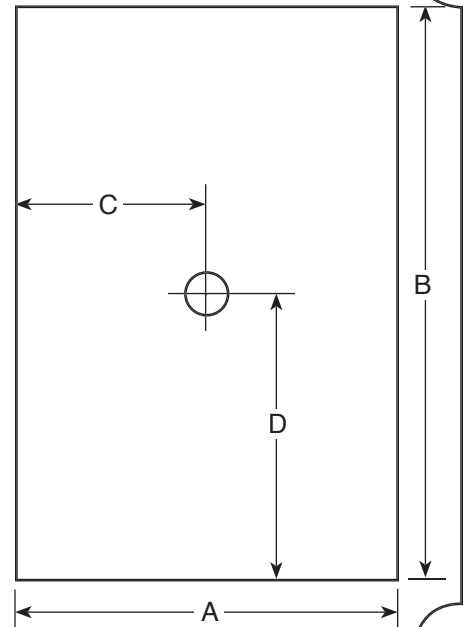

ROUGH-IN MODEL 1700 SERIES

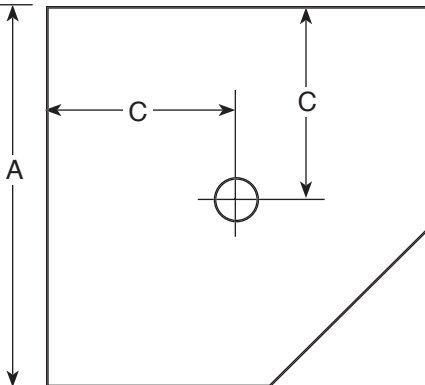

MODEL	A		B		C	
	IN	MM	IN	MM	IN	MM
SBC-1700	24	610	24	610	12	305
SBC-1702	24	610	24	610	12	305
SBC-1725	32	813	32	813	12	305
SBC-1750	36	915	36	915	12	305

Note: All dimensions subject to manufacturing variance of plus or minus 1/4" (6 MM).