

Rinnai®

Tankless Rack System (TRS) Installation Manual

Additional information can be obtained from the appliance manual.

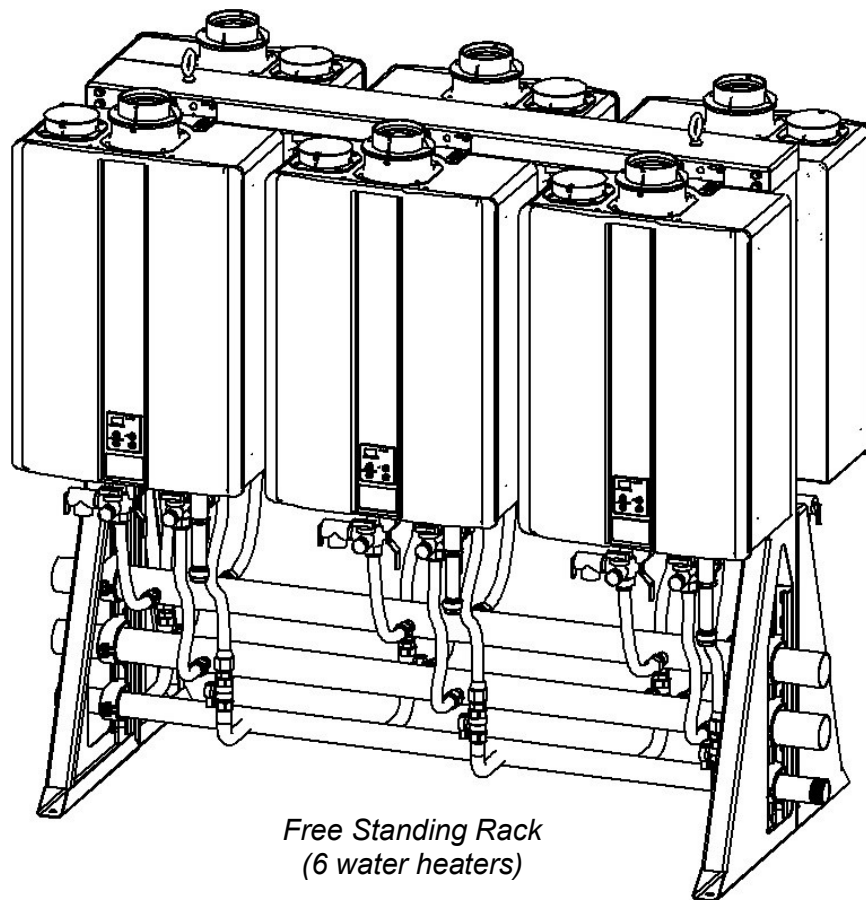

*Free Standing Rack
(6 water heaters)*

⚠ WARNING If the information in these instructions is not followed exactly, a fire or explosion may result causing property damage, personal injury or death.

- Do not store or use gasoline or other flammable vapors and liquids in the vicinity of this or any other appliance.
- **WHAT TO DO IF YOU SMELL GAS**
 - Do not try to light any appliance.
 - Do not touch any electrical switch; do not use any phone in your building.
 - Immediately call your gas supplier from a neighbor's phone. Follow the gas supplier's instructions.
 - If you cannot reach your gas supplier, call the fire department.
- Installation and service must be performed by a licensed professional.

Notes

A large grid of graph paper for taking notes, consisting of 20 columns and 30 rows of small squares.

Table of Contents

Description	4	End caps / Connections.....	26
Venting Options.....	4	Condensate Drain.....	27
TRS Part Nos. and Main Components.....	5	Checklist for Plumbing.....	27
Specifications	7-18	Installation of Gas Supply.....	28
Clearances	19	Connecting Electricity	28
Hoisting	20	MSB Installation.....	29-30
Securing Racks	21-23	Final Checklist	31
Relief Valve Piping	24	Replacement Parts	32-33
Piping for Multiple Racks.....	24	Extended Limited Labor Warranty	34-35
Parallel Piping Drawing	25		

Safety Symbols



This is the safety alert symbol. This symbol alerts you to potential hazards that can kill or hurt you and others.



Indicates an imminently hazardous situation which, if not avoided, will result in death or serious injury.



Indicates a potentially hazardous situation which, if not avoided, could result in death or serious injury.



Indicates a potentially hazardous situation which, if not avoided, could result in minor or moderate injury. It may also be used to alert against unsafe practices.

Installation

A licensed professional must install the (TRS) Tankless Rack System

The installer should have skills such as

- connecting gas lines, water lines, valves, and electricity
- knowledge of applicable national, state, and local codes

If you lack these skills, contact a licensed professional.

Description

Rinnai Tankless Rack Systems (TRS) include wall mounted and free standing configurations. The wall mounted rack systems are available for 2 or 3 water heaters. Free standing rack systems are available for 2, 3, 4, 5, or 6 water heaters.

The TRS can be ordered with Rinnai’s Common Venting System, which consists of the CVent exhaust venting and PP or PVC intake venting. Up to eight tankless units can share the same CVent system.

The Rinnai TRS features design details that make installation simple and straightforward.

- Maneuverability: Fits, fully assembled, through standard 32-inch doorways and on elevators
- Flexibility: Available in both wall-mount or freestanding design for indoor and outdoor installations.
- Preassembled Gas and water manifolds are properly sized to maintain optimum performance.
- The racks are constructed of powder-coated aluminum, powder coated steel, and stainless to stand up to the most demanding commercial environments, while minimizing weight.
- Optional electronic controls to obtain turn down ratios of up to 327:1 (Sold Separately).

NOTE: The TRS is designed to be used with Rinnai tankless water heaters only. Do not mount non-Rinnai water heaters on the TRS.

Venting Options







Venting Options	Exhaust Vent Material	Intake Vent Material	Diameter	Max. Units	Max. Vent Length	
					Natural Gas	Propane
Common Venting System *	PPTl, PPs	PVC, PPTl, PPS	8"	8	100' (with 7 units) or 41' (with 8 units)	
Concentric	PPs	PVC	5"	1	65'	45'
Twin Pipe PVC/CPVC	PVC/CPVC	PVC/CPVC	4"	1	100'	65'
			3"	1	65'	41'
Dual Pipe*	PPs	PPs or PVC	3"	1	41'	41'
* This venting is provided by Centrotherm through their own distribution network						

- Refer to the water heater installation and operation manual for specific details regarding vent installation option and installation.
- Venting components are packaged separately from the pre-assembled Rack for field assembly of the vent system by the contractor.



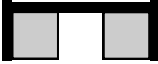

* **Only the C199i is certified for both direct vent and exhaust only with room air (exhaust must terminate vertically in room air application) when installed in a commercial common vent application only. Reference Rinnai Common Vent (CVent) Manual for further information.**

TRS Part Nos. and Main Components

Tankless Rack WALL HANGING

Part No.*	Rack type	Configuration	Illustration
TRW02iN	2-unit interior wall hanging rack, NG		
TRW02eN	2-unit exterior wall hanging rack, NG		
TRW02iP	2-unit interior wall hanging rack, LP		
TRW02eP	2-unit exterior wall hanging rack, LP		
TRW23iN	2-unit interior wall hanging rack, NG		
TRW23eN	2-unit exterior wall hanging rack, NG		
TRW23iP	2-unit interior wall hanging rack, LP		
TRW23eP	2-unit exterior wall hanging rack, LP		
TRW03iN	3-unit interior wall hanging rack, NG		
TRW03eN	3-unit exterior wall hanging rack, NG		
TRW03iP	3-unit interior wall hanging rack, LP		
TRW03eP	3-unit exterior wall hanging rack, LP		

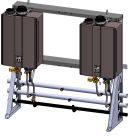







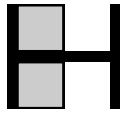
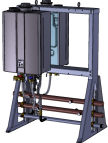

Tankless Rack INLINE WALL MOUNT

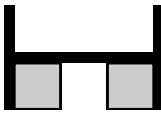
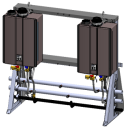
Part No.*	Rack type	Configuration	Illustration
TRS02iLWiN	2-unit interior wall mount rack, NG		
TRS02iLWeN	2-unit exterior wall mount rack, NG		
TRS02iLWiP	2-unit interior wall mount rack, LP		
TRS02iLWeP	2-unit exterior wall mount rack, LP		
TRS23iLWiN	2-unit interior wall mount rack, NG		
TRS23iLWeN	2-unit exterior wall mount rack, NG		
TRS23iLWiP	2-unit interior wall mount rack, LP		
TRS23iLWeP	2-unit exterior wall mount rack, LP		
TRS03iLWiN	3-unit interior wall mount rack, NG		
TRS03iLWeN	3-unit exterior wall mount rack, NG		
TRS03iLWiP	3-unit interior wall mount rack, LP		
TRS03iLWeP	3-unit exterior wall mount rack, LP		

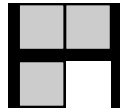
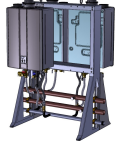
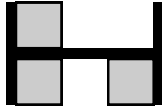
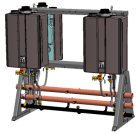
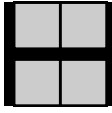
Part no. system: TR = tankless rack; W = wall hanging; S = stand alone; IL = inline; ILW = Inline Wall Mount; 2/3/4/5/6 = no. of water heaters; i/e = interior/exterior; NG/LP = fuel type

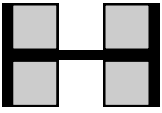
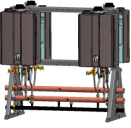
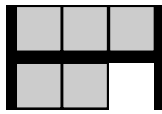
TRS Part Nos. and Main Components

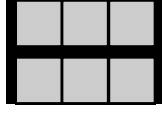
Tankless Rack FREESTANDING

Part No.*	Rack type	Configuration	Illustration
TRS02iN	2-unit interior free standing rack, NG	Back to Back 	
TRS02eN	2-unit exterior free standing rack, NG		
TRS02iP	2-unit interior free standing rack, LP		
TRS02eP	2-unit exterior free standing rack, LP		
TRS02ILiN	2-unit INLINE interior free standing rack, NG		
TRS02ILeN	2-unit INLINE exterior free standing rack, NG		
TRS02ILiP	2-unit INLINE interior free standing rack, LP		
TRS02ILeP	2-unit INLINE exterior free standing rack, LP		
TRS23ILiN	2-unit INLINE interior free standing rack, NG		
TRS23ILeN	2-unit INLINE exterior free standing rack, NG		
TRS23ILiP	2-unit INLINE interior free standing rack, LP		
TRS23ILeP	2-unit INLINE exterior free standing rack, LP		
TRS03ILiN	3-unit INLINE interior free standing rack, NG		
TRS03ILeN	3-unit INLINE exterior free standing rack, NG		
TRS03ILiP	3-unit INLINE interior free standing rack, LP		
TRS03ILeP	3-unit INLINE exterior free standing rack, LP		
TRS03iN	3-unit interior free standing rack, NG		
TRS03eN	3-unit exterior free standing rack, NG		
TRS03iP	3-unit interior free standing rack, LP		
TRS03eP	3-unit exterior free standing rack, LP		
TRS36iN	3-unit interior free standing rack, NG		
TRS36eN	3-unit exterior free standing rack, NG		
TRS36iP	3-unit interior free standing rack, LP		
TRS36eP	3-unit exterior free standing rack, LP		
TRS04iN	4-unit interior free standing rack, NG		
TRS04eN	4-unit exterior free standing rack, NG		
TRS04iP	4-unit interior free standing rack, LP		
TRS04eP	4-unit exterior free standing rack, LP		
TRS46iN	4-unit interior free standing rack, NG		
TRS46eN	4-unit exterior free standing rack, NG		
TRS46iP	4-unit interior free standing rack, LP		
TRS46eP	4-unit exterior free standing rack, LP		
TRS05iN	5-unit interior free standing rack, NG		
TRS05eN	5-unit exterior free standing rack, NG		
TRS05iP	5-unit interior free standing rack, LP		
TRS05eP	5-unit exterior free standing rack, LP		
TRS06iN	6-unit interior free standing rack, NG		
TRS06eN	6-unit exterior free standing rack, NG		
TRS06iP	6-unit interior free standing rack, LP		
TRS06eP	6-unit exterior free standing rack, LP		

Part no. system: TR = tankless rack; W = wall hanging; S = stand alone; IL = inline; ILW = Inline Wall Mount; 2/3/4/5/6 = no. of water heaters; i/e = interior/exterior; NG/LP = fuel type

Specifications

2 UNIT WALL HANGING FRAME

LEFT

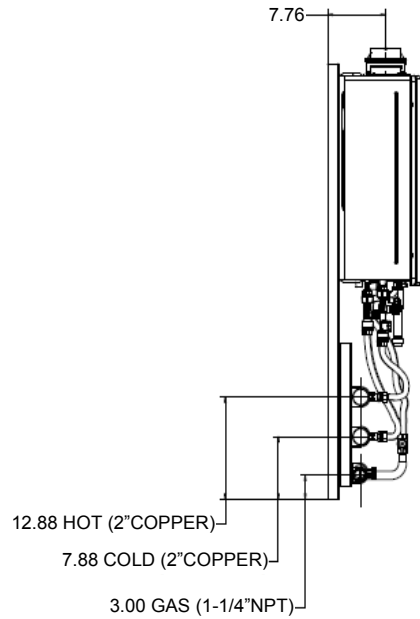

FRONT

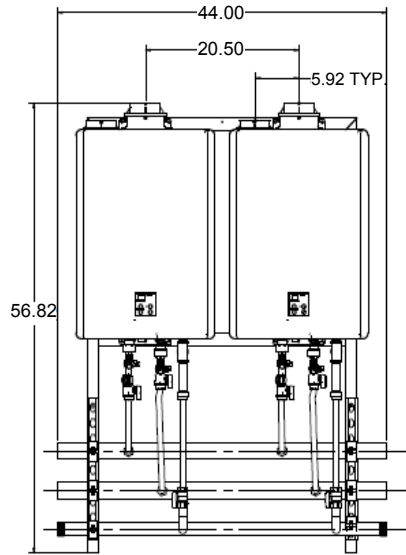

BACK

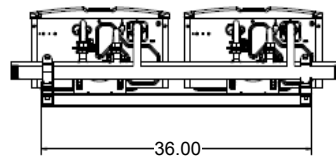
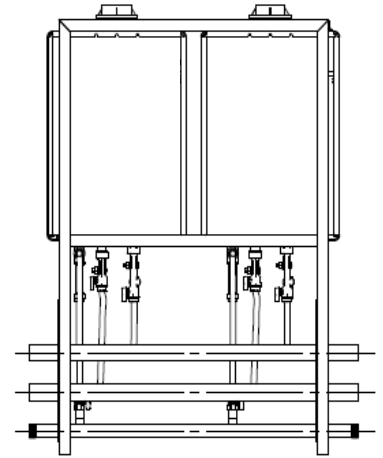

BOTTOM

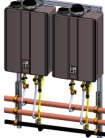
Model	Configuration	Illustration
TRW02		

Specifications

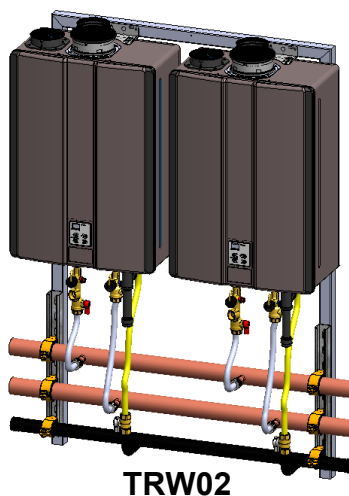

2 UNIT WALL HANGING FRAME		
Model	TRW02i	TRW02e
Water Heater Model	RUC98i, C199i (NG/LP)	RU98e, C199e (NG/LP)
Crate Dimensions (HxLxD) - in	62 x 55 x 36	
Weight - Fully Assembled - lbs	166	165
Weight - Shipping (total) - lbs	380	379
Rack Frame - Specifications		
Frame Material	14 Gauge Hot Rolled Steel 1.5" Square Tube	16 Gauge Stainless Steel 1.5" Square Tube
Frame Finish	Powder Coat	Stainless
Color	Gray	Stainless
Water & Gas Connections		
Hot Water Trunk Line Diameter	2"	
Cold Water Trunk Line Diameter	2"	
Hot Water Trunk Line Material	Rigid Copper	
Cold Water Trunk Line Material	Rigid Copper	
Water Trunk Connection Type	2" PIPE	
Gas Trunk Line Diameter	1-1/4"	
Gas Trunk Connection Type	1-1/4" MNPT	
Gas Trunk Line Material	Sch 40 Steel	
Gas Branch Line Material	PVC Over CSST	
Electric Requirements		
Voltage	AC 120 Volts—60 Hz	
Maximum Current (Amperes)	8	
BTU and Flow Rates for RU98i, RUC98i, C199i, RU98e, C199e (NG/LP)		
Number of Tankless Water Heaters	2	
Flow rate @ 70°F rise (gpm)	10.8	
Flow rate @ 100°F rise (gpm)	7.6	
Minimum input rate (Btuh)	15,200	
Maximum input rate (Btuh)	398,000	

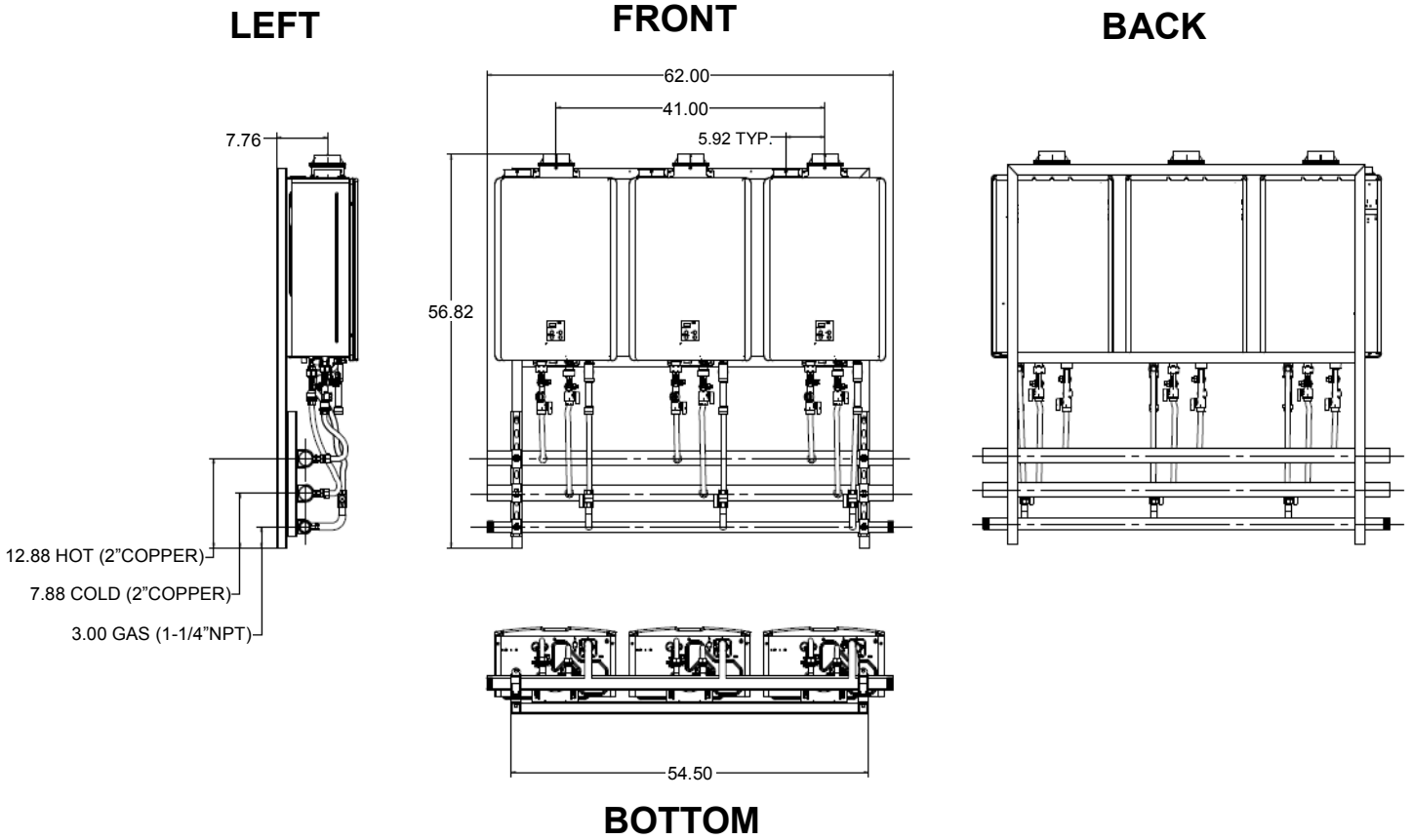

Specifications

3 UNIT WALL HANGING FRAME

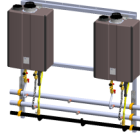

Model	Configuration	Illustration
TRW03		
TRW23		

Specifications

3 UNIT WALL HANGING FRAME				
Model	TRW03i	TRW03e	TRW23i	TRW23e
Water Heater Model	RU98i, RUC98i, C199i (NG/LP)	RU98e, C199e (NG/LP)	RU98i, RUC98i, C199i (NG/LP)	RU98e, C199e (NG/LP)
Crate Dimensions (HxLxD) - in	62 x 75 x 36		62 x 75 x 36	
Weight - Fully Assembled - lbs	244	240	182	179
Weight - Shipping (total) - lbs	458	454	396	393
Rack Frame - Specifications				
Frame Material	14 Gauge Hot Rolled Steel 1.5" Square Tube	16 Gauge Stainless Steel 1.5" Square Tube	14 Gauge Hot Rolled Steel 1.5" Square Tube	16 Gauge Stainless Steel 1.5" Square Tube
Frame Finish	Powder Coat	Stainless	Powder Coat	Stainless
Color	Gray	Stainless	Gray	Stainless
Water & Gas Connections				
Hot Water Trunk Line Diameter	2"			
Cold Water Trunk Line Diameter	2"			
Hot Water Trunk Line Material	Rigid Copper			
Cold Water Trunk Line Material	Rigid Copper			
Water Trunk Connection Type	2" PIPE			
Gas Trunk Line Diameter	1-1/4"			
Gas Trunk Connection Type	1-1/4" MNPT			
Gas Trunk Line Material	Sch 40 Steel			
Gas Branch Line Material	PVC Over CSST			
Electric Requirements				
Voltage	AC 120 Volts—60 Hz			
Maximum Current (Amperes)	12		8	
BTU and Flow Rates for RU98i, RUC98i, C199i, RU98e, C199e (NG/LP)				
Number of Tankless Water Heaters	3		2	
Flow rate @ 70°F rise (gpm)	16.2		10.8	
Flow rate @ 100°F rise (gpm)	11.4		7.6	
Minimum input rate (Btuh)	15,200		15,200	
Maximum input rate (Btuh)	597,000		398,000	

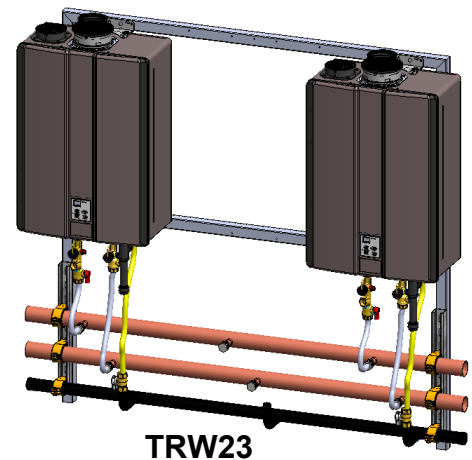
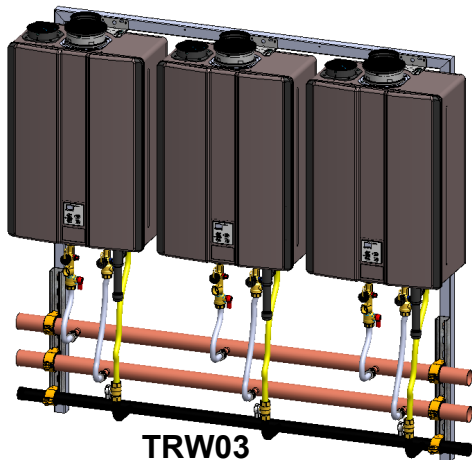

Rinnai Rack Installation

Specifications

2 UNIT WALL MOUNT FRAME

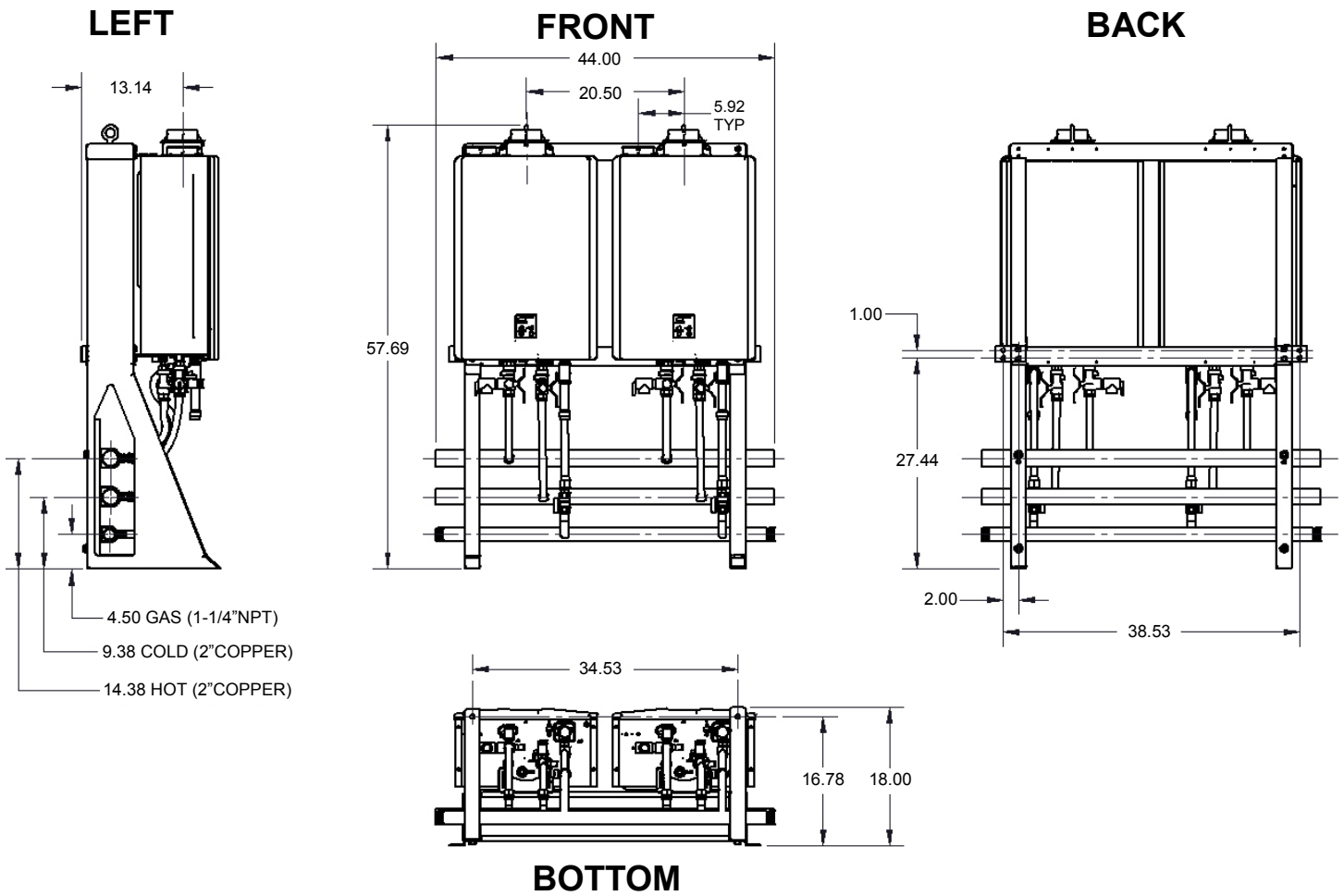

Model	Configuration	Illustration
TRW02		

Specifications

2 UNIT WALL MOUNT FRAME	
Model	TRS02ILW
Water Heater Model	RU98i, RUC98i, C199i, RU98e, C199e (NG/LP)
Crate Dimensions (HxLxD) - in	62 x 55 x 36
Weight - Fully Assembled - lbs	204
Weight - Shipping (total) - lbs	400
Rack Frame - Specifications	
Frame Rail Type	Sheet Metal
Frame Material	Aluminum (0.090 5052-H32)
Frame Finish	Powder Coat
Color	Gray
Water & Gas Connections	
Hot Water Trunk Line Diameter	2"
Cold Water Trunk Line Diameter	2"
Hot Water Trunk Line Material	Rigid Copper
Cold Water Trunk Line Material	Rigid Copper
Water Trunk Connection Type	2" PIPE
Gas Trunk Line Diameter	1-1/4"
Gas Trunk Connection Type	1-1/4" MNPT
Gas Trunk Line Material	Sch 40 Steel
Gas Branch Line Material	PVC Over CSST
Electric Requirements	
Voltage	AC 120 Volts—60 Hz
Maximum Current (Amperes)	8
BTU and Flow Rates for RU98i, RUC98i, C199i, RU98e, C199e (NG/LP)	
Number of Tankless Water Heaters	2
Flow rate @ 70°F rise (gpm)	10.8
Flow rate @ 100°F rise (gpm)	7.6
Minimum input rate (Btuh)	15,200
Maximum input rate (Btuh)	398,000



TRS02ILW

Specifications

3 UNIT WALL MOUNT FRAME

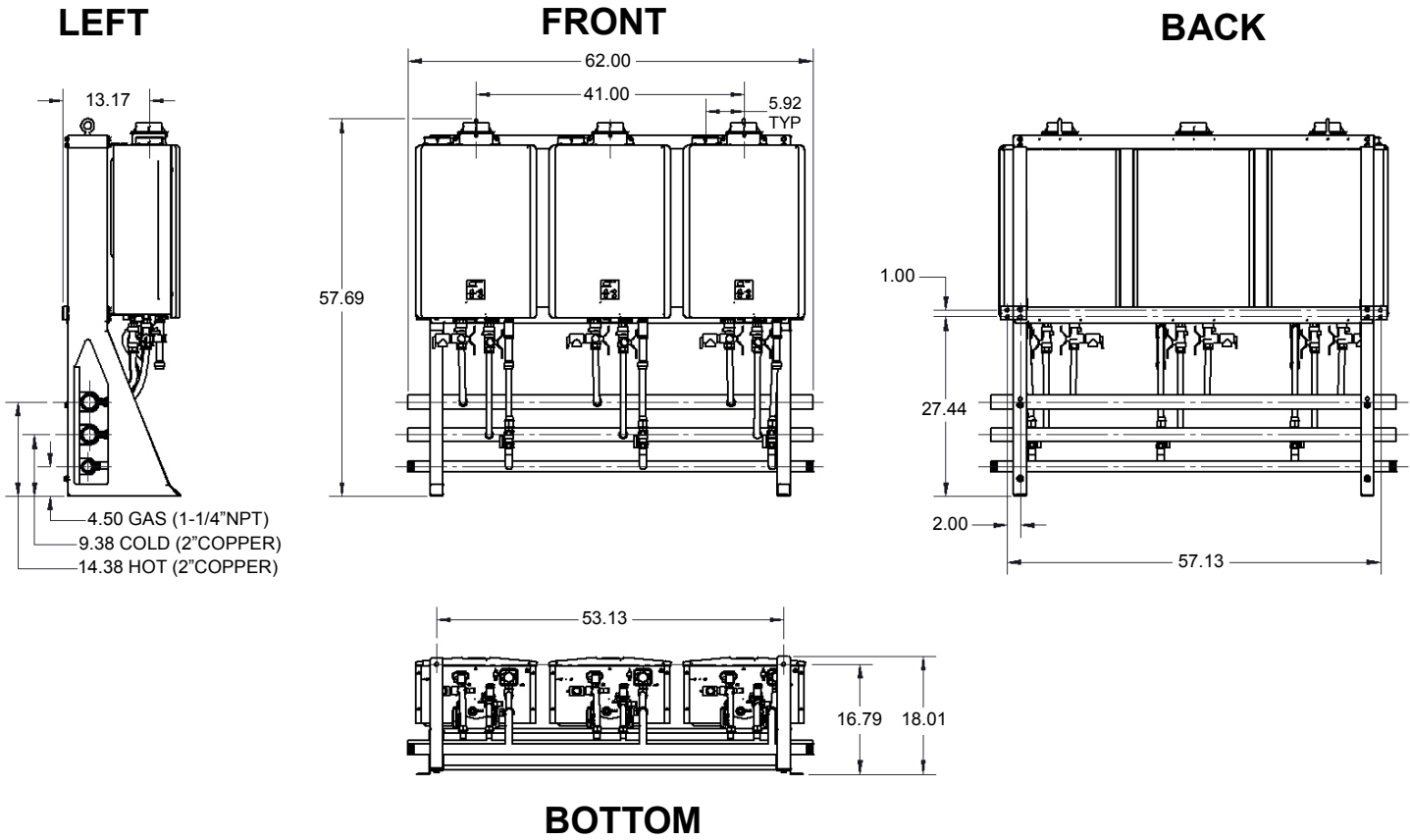

Model	Configuration	Illustration
TRS03ILW		
TRS23ILW		

Specifications

3 UNIT WALL MOUNT FRAME		
Model	TRS03ILW	TRS23ILW
Water Heater Model	RU98i, RUC98i, C199i, RU98e, C199e (NG/LP)	
Crate Dimensions (HxLxD) - in	62 x 75 x 36	
Weight - Fully Assembled - lbs	291	218
Weight - Shipping (total) - lbs	487	414
Rack Frame - Specifications		
Frame Rail Type	Sheet Metal	
Frame Material	Aluminum (0.090 5052-H32)	
Frame Finish	Powder Coat	
Color	Gray	
Water & Gas Connections		
Hot Water Trunk Line Diameter	2"	
Cold Water Trunk Line Diameter	2"	
Hot Water Trunk Line Material	Rigid Copper	
Cold Water Trunk Line Material	Rigid Copper	
Water Trunk Connection Type	2" PIPE	
Gas Trunk Line Diameter	1-1/4"	
Gas Trunk Connection Type	1-1/4" MNPT	
Gas Trunk Line Material	Sch 40 Steel	
Gas Branch Line Material	PVC Over CSST	
Electric Requirements		
Voltage	AC 120 Volts—60 Hz	
Maximum Current (Amperes)	12	
BTU and Flow Rates for RU98i, RUC98i, C199i, RU98e, C199e (NG/LP)		
Number of Tankless Water Heaters	3	2
Flow rate @ 70°F rise (gpm)	16.2	10.8
Flow rate @ 100°F rise (gpm)	11.4	7.6
Minimum input rate (Btuh)	15,200	15,200
Maximum input rate (Btuh)	597,000	398,000

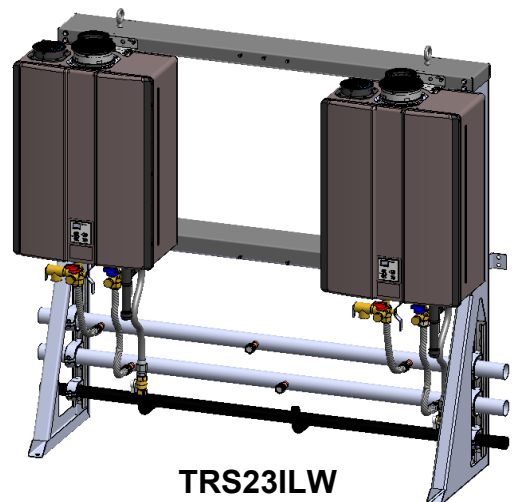

Specifications

4 UNIT FREE STANDING FRAME

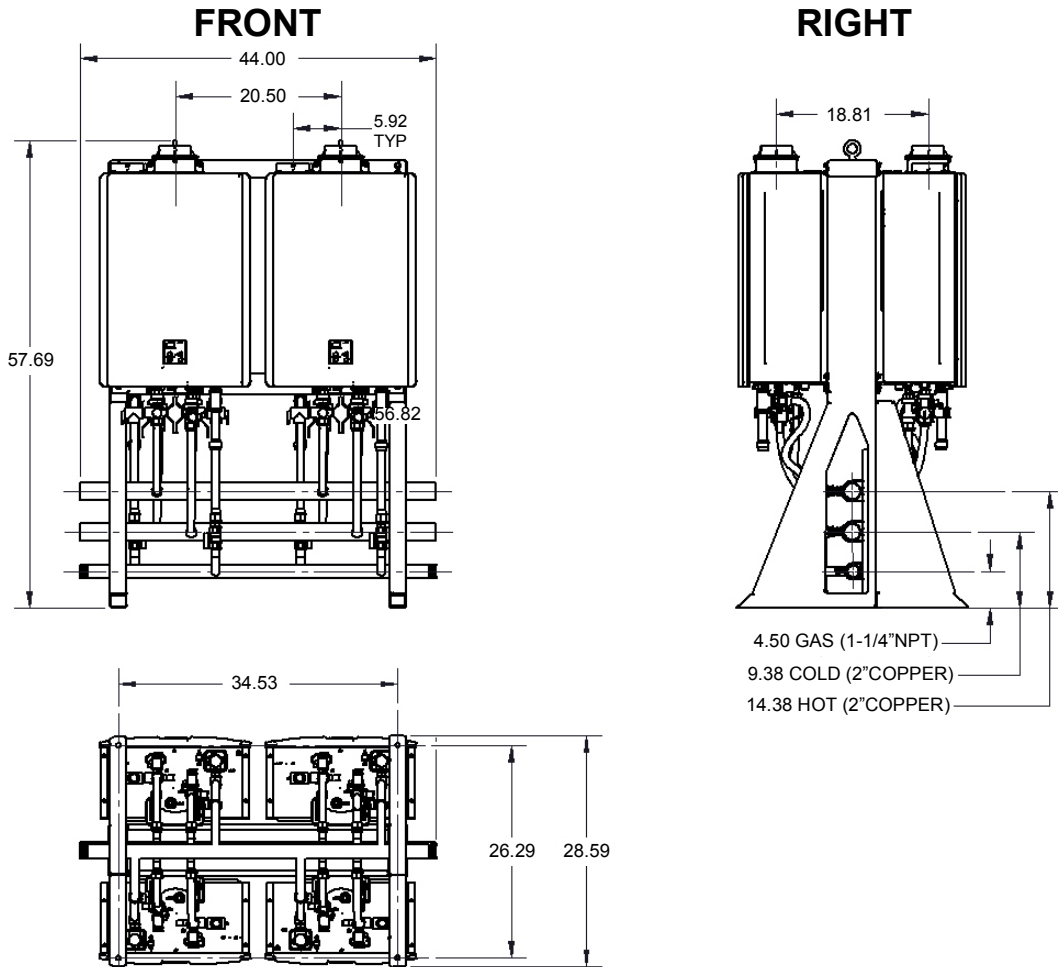

BOTTOM

Model	Configuration	Illustration
TRS04		
TRS03		
TRS02IL	Inline (facing same direction)	
TRS02	Back to Back	

Specifications

4 UNIT FREE STANDING FRAME				
Model	TRS04	TRS03	TRS02	TRS02IL
Water Heater Model	RU98i, RUC98i, C199i, RU98e, C199e (NG/LP)			
Crate Dimensions (HxLxD) - in	62 x 55 x 36			
Weight - Fully Assembled - lbs	357	284	210	208
Weight - Shipping (total) - lbs	553	480	406	404
Rack Frame - Specifications				
Frame Rail Type	Sheet Metal			
Frame Material	Aluminum (0.090 5052-H32)			
Frame Finish	Powder Coat			
Color	Gray			
Water & Gas Connections				
Hot Water Trunk Line Diameter	2"			
Cold Water Trunk Line Diameter	2"			
Hot Water Trunk Line Material	Rigid Copper			
Cold Water Trunk Line Material	Rigid Copper			
Water Trunk Connection Type	2" PIPE			
Gas Trunk Line Diameter	1-1/4"			
Gas Trunk Connection Type	1-1/4" MNPT			
Gas Trunk Line Material	Sch 40 Steel			
Gas Branch Line Material	PVC Over CSST			
Electric Requirements				
Voltage	AC 120 Volts—60 Hz			
Maximum Current (Amperes)	16	12	8	8
BTU and Flow Rates for RU98i, RUC98i, C199i, RU98e, C199e (NG/LP)				
Number of Tankless Water Heaters	4	3	3	2
Flow rate @ 70°F rise (gpm)	21.6	16.2	16.2	10.8
Flow rate @ 100°F rise (gpm)	15.2	11.4	11.4	7.6
Minimum input rate (Btuh)	15,200			
Maximum input rate (Btuh)	796,000	597,000	597,000	398,000

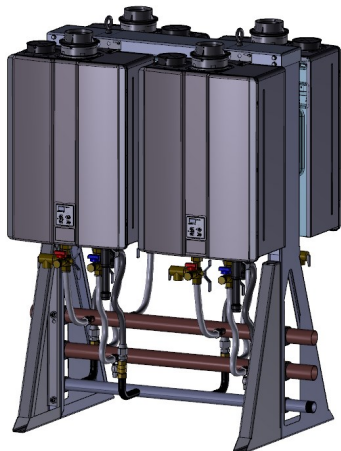

TRS04

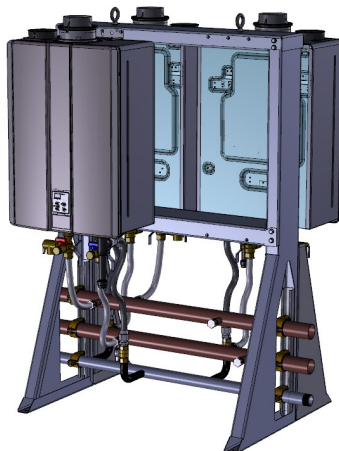

TRS03

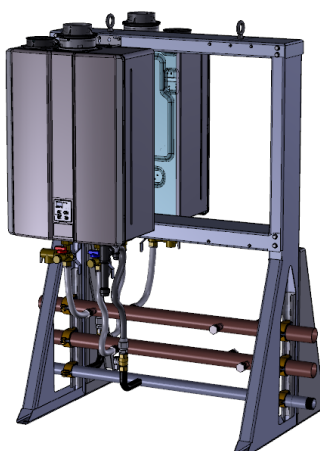

TRS02

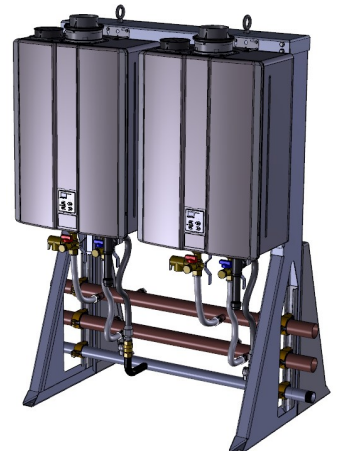

TRS02IL

Specifications

6 UNIT FREE STANDING FRAME

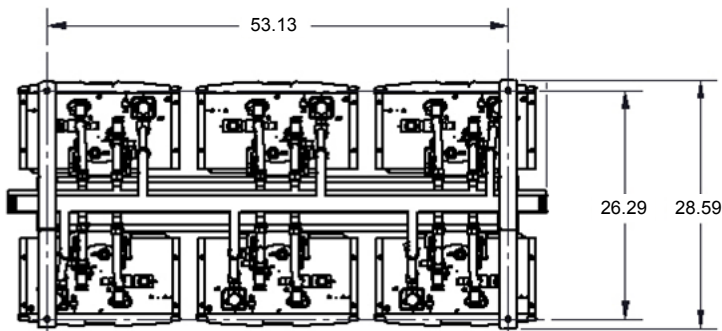
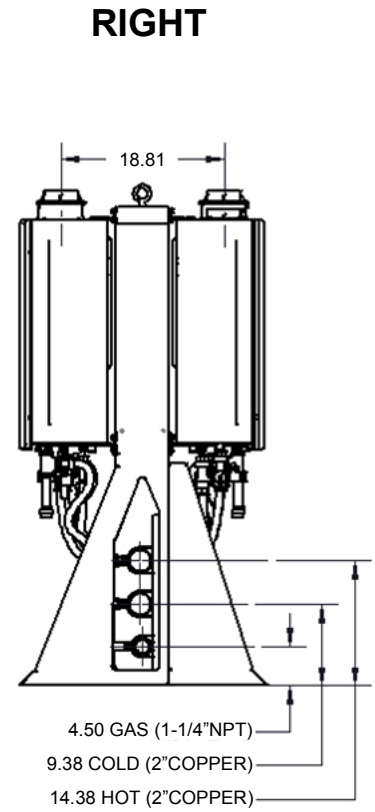
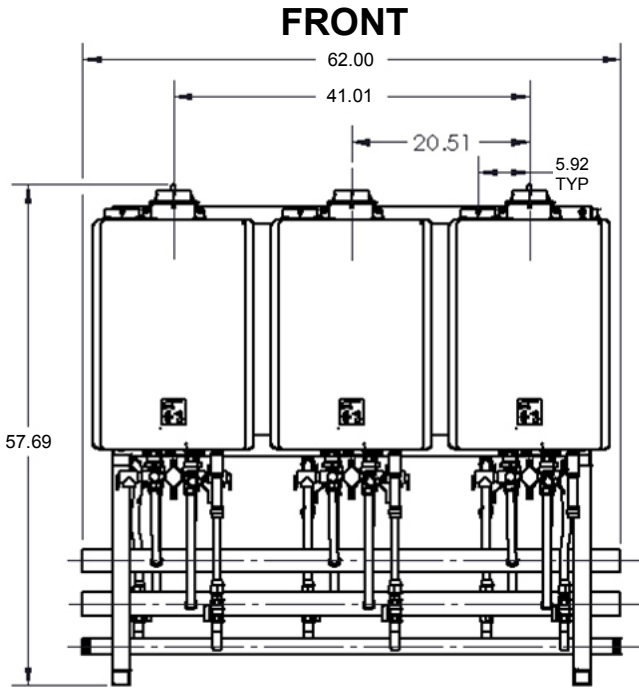

Model	Configuration	Illustration	Model	Configuration	Illustration
TRS06			TRS06		
TRS05			TRS46		
TRS03IL			TRS23IL		

Specifications

6 UNIT FREE STANDING FRAME						
Model	TRS06	TRS05	TRS46	TRS36	TRS03IL	TRS23IL
Water Heater Model	RU98i, RUC98i, C199i, RU98e, C199e (NG/LP)					
Crate Dimensions (HxLxD) - in	62 x 75 x 36					
Weight - Fully Assembled - lbs	526	452	378	284	284	210
Weight - Shipping (total) - lbs	722	649	576	480	480	406
Rack Frame - Specifications						
Frame Rail Type	Sheet Metal					
Frame Material	Aluminum (0.090 5052-H32)					
Frame Finish	Powder Coat					
Color	Gray					
Water & Gas Connections						
Hot Water Trunk Line Diameter	2-1/2"				2"	
Cold Water Trunk Line Diameter	2-1/2"				2"	
Hot Water Trunk Line Material	Rigid Copper					
Cold Water Trunk Line Material	Rigid Copper					
Water Trunk Connection Type	2-1/2" PIPE				2" PIPE	
Gas Trunk Line Diameter	1-1/2"				1-1/4"	
Gas Trunk Connection Type	1-1/2" MNPT				1-1/4" MNPT	
Gas Trunk Line Material	Sch 40 Steel					
Gas Branch Line Material	PVC Over CSST					
Electric Requirements						
Voltage	AC 120 Volts—60 Hz					
Max Current (Amperes)	24	20	16	12	12	8
BTU and Flow Rates for RU98i, RUC98i, C199i, RU98e, C199e (NG/LP)						
Number of Tankless Water Heaters	6	5	3	4	2	
Flow rate @ 70°F rise (gpm)	32.4	27.0	16.2	21.6	10.8	
Flow rate @ 100°F rise (gpm)	22.8	19.0	11.4	15.1	7.6	
Minimum input rate (Btuh)	15,200					
Maximum input rate (Btuh)	1,194,000	995,000	597,000	796,000	398,000	



TRS06

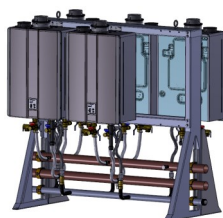

TRS05



TRS03IL

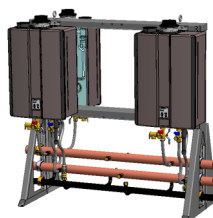

TRS36

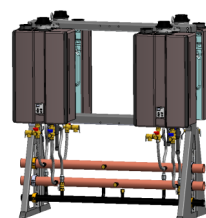

TRS46

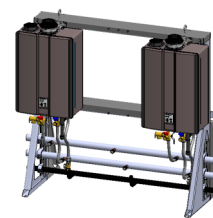

TRS23IL

Clearances

Install the rack system so that the clearances shown below (specified for the water heater in the RUC98i and RU98e installation manual) are followed.

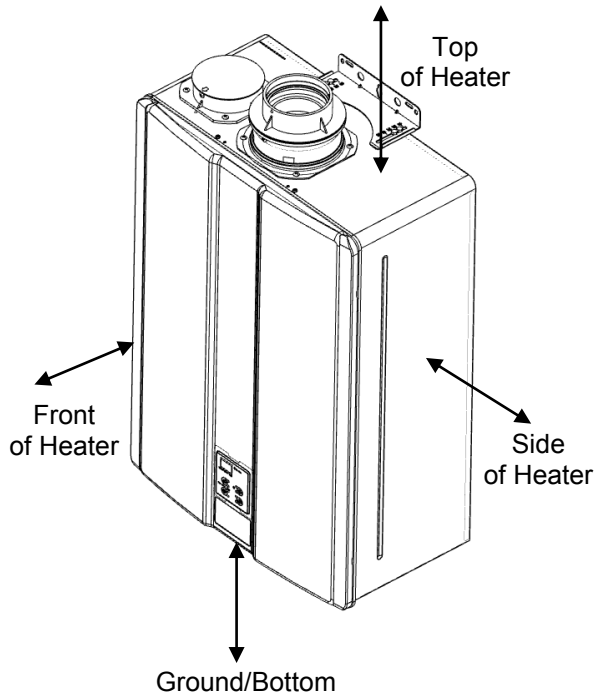

Indoor models: RU98i, RUC98i, C199i

	to Combustibles inches (mm)	to Non-Combustibles inches (mm)
Top of Heater	6 * (152)	2 *(51)
Back of Heater	0 (zero)	0 (zero)
Front of Heater	6 (152)	6 (152)
Sides of Heater	2 (51)	1/2 (13)
Ground/Bottom	12 (305)	12 (305)
Vent	0 (zero)	0 (zero)

* 0 inches from vent components and condensate drain line.

The clearance for servicing is 24 inches in front of the water heater.

For closet installation, clearance is 6 inches (152 mm) from the front.

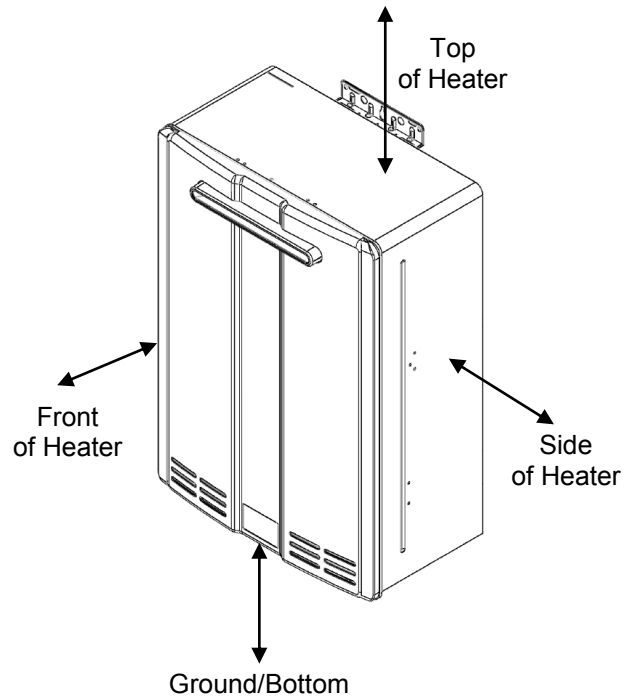

Outdoor models: RU98e, C199e

	to Combustibles inches (mm)	to Non-Combustibles inches (mm)
Top of Heater	12 (305)	2 (51)
Back of Heater	0 (zero)	0 (zero)
Front (panel)	24 (610)	0 (zero)
Front (exhaust)	24 (610)	24 (610)
Sides of Heater	6 (152)	1/8 (3.2)
Ground/Bottom	12 (305)	2 (51)

The clearance for servicing is 24 inches in front of the water heater.

Hoisting (Lifting Lugs)

Lugs are installed on the top side of the following racks for hoisting and moving. The lines or cables to the lugs should be at a 90° angle. Use a spreader lifting bar to hoist these racks.

Weights of the complete assemblies are available in the Specifications section of this manual.

NOTE: DO NOT hoist the crate or palette.

MODELS AVAILABLE WITH LIFTING LUGS

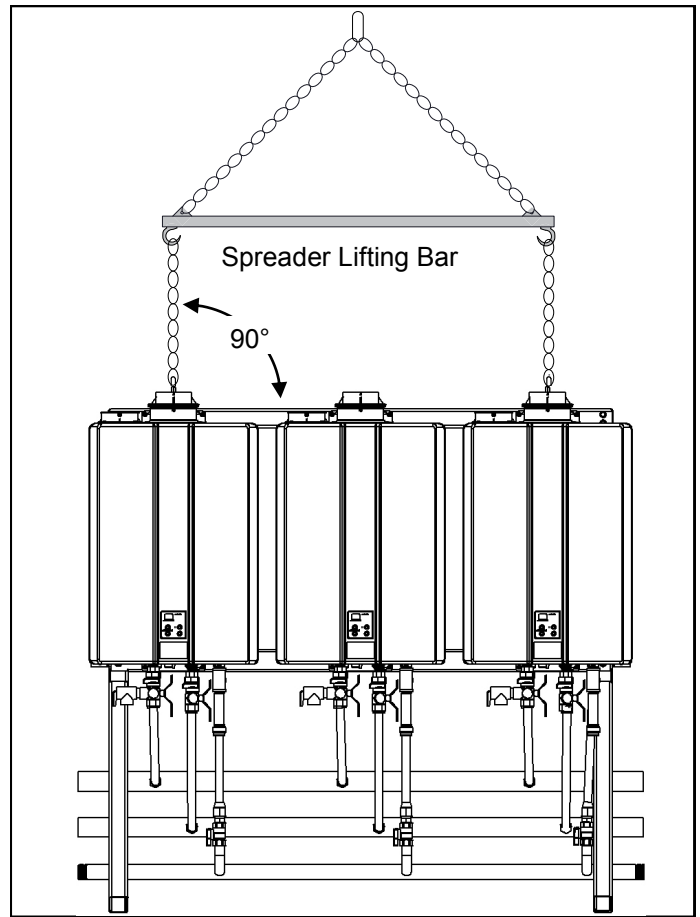
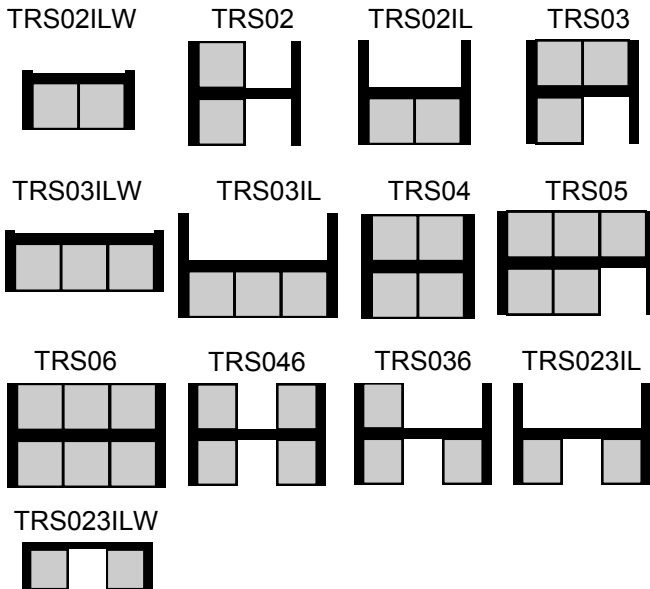

Hoisting (Straps)

For the TRW02 and TRW03 wall mounted racks, use hoisting straps looped around the top frame.

Weights of the complete assemblies are available in the Specifications section of this manual.

NOTE: DO NOT hoist the crate or palette.

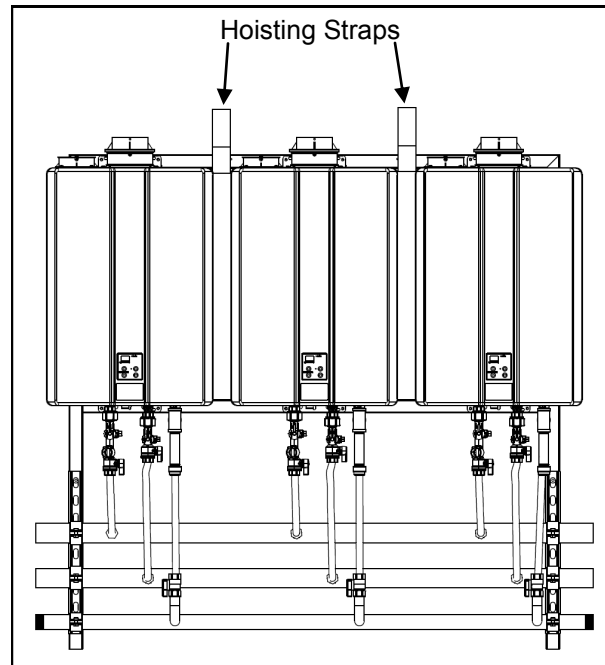
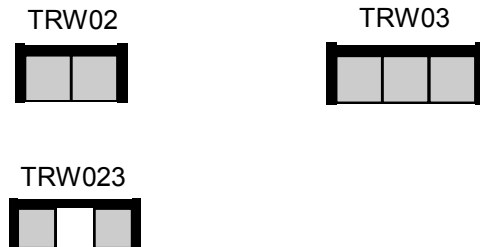

Securing Free Standing Racks

1. Use 4-1/2" HILTI KB-TZ expansion anchors or approved equivalent. Minimum embedment (hef) = 3.25". Minimum concrete thickness to be 6".
2. All mechanical components shall be anchored and installed per the notes in this manual. Where no detail is indicated, anchorage of equipment to building structure shall be in accordance to the applicable national and/or local codes having jurisdiction.
3. The size and embedment specified are for anchors installed in stone or aggregate concrete only, for other anchorage details the contractor or engineer on record for the building shall consult with a licensed structural engineer for all anchorage of equipment not called out in this manual.
4. In the event of a conflict or inconsistency between items indicated in this manual with code requirements, the more stringent standard shall prevail.

FREE STANDING MODELS AVAILABLE

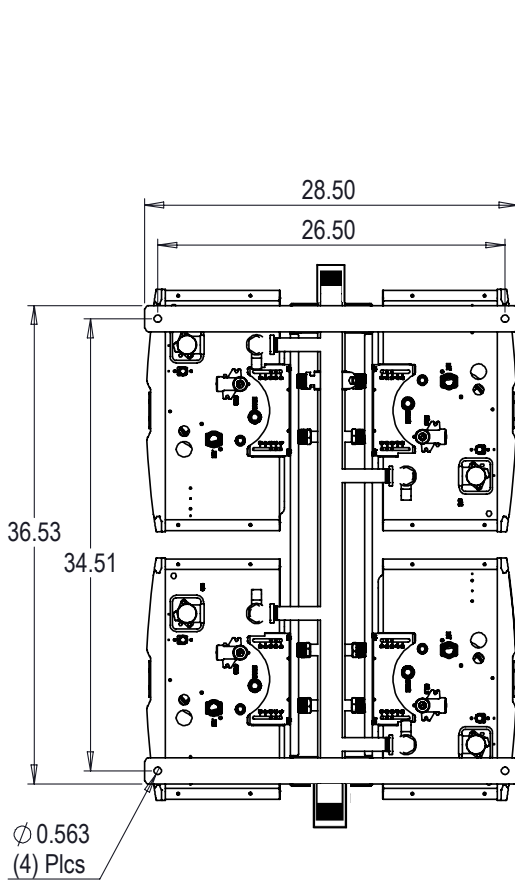
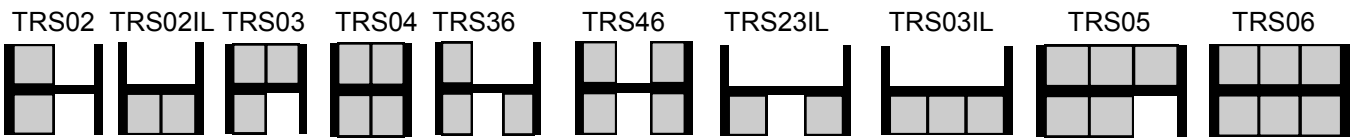

Bottom view of free standing racks.
(Flex line illustrations have been removed for clarity)

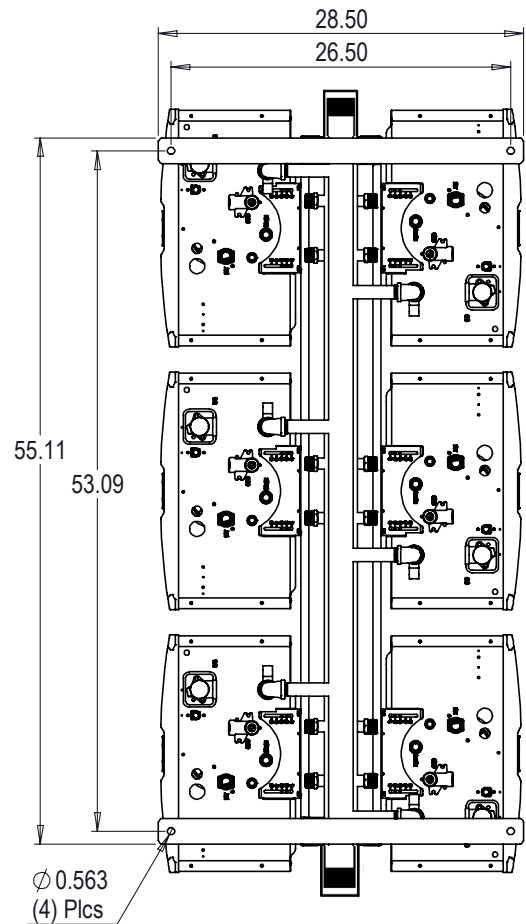

Securing Wall Mount Racks (ILW)

WARNING THE WALL MUST BE CAPABLE OF CARRYING THE OPERATING WEIGHT OF THE INSTALLED TRS SYSTEM. CONSULT A STRUCTURAL ENGINEER FOR STRUCTURAL ANALYSIS OF THE WALL AND APPROPRIATE HANGING METHODS BEFORE ATTEMPTING TO HANG THE TRS SYSTEM. FAILURE TO COMPLY WITH THE ABOVE REQUIREMENT COULD RESULT IN SUBSTANTIAL PROPERTY DAMAGE, SEVERE PERSONAL INJURY OR DEATH.

- Identify the installation location and confirm that the installation will meet all required clearances.
- The size and embedment specified are for anchors installed in stone or aggregate concrete only, for other anchorage details the contractor or engineer on record for the building shall consult with a licensed structural engineer for all anchorage of equipment not called out in this manual.
- In the event of a conflict or inconsistency between items indicated in this manual with code requirements, the more stringent standard shall prevail.

WALL RACK MODELS AVAILABLE

TRS02ILW, TRS03ILW, & TRS23ILW

1. Using the holes in the wall bracket, Securely attach the rack to the wall. Ensure that the attachment strength is sufficient.
2. For floor anchors, use 4-1/2" HILTI KB-TZ expansion anchors or approved equivalent. Minimum embedment (hef) = 3.25". Minimum concrete thickness to be 6".

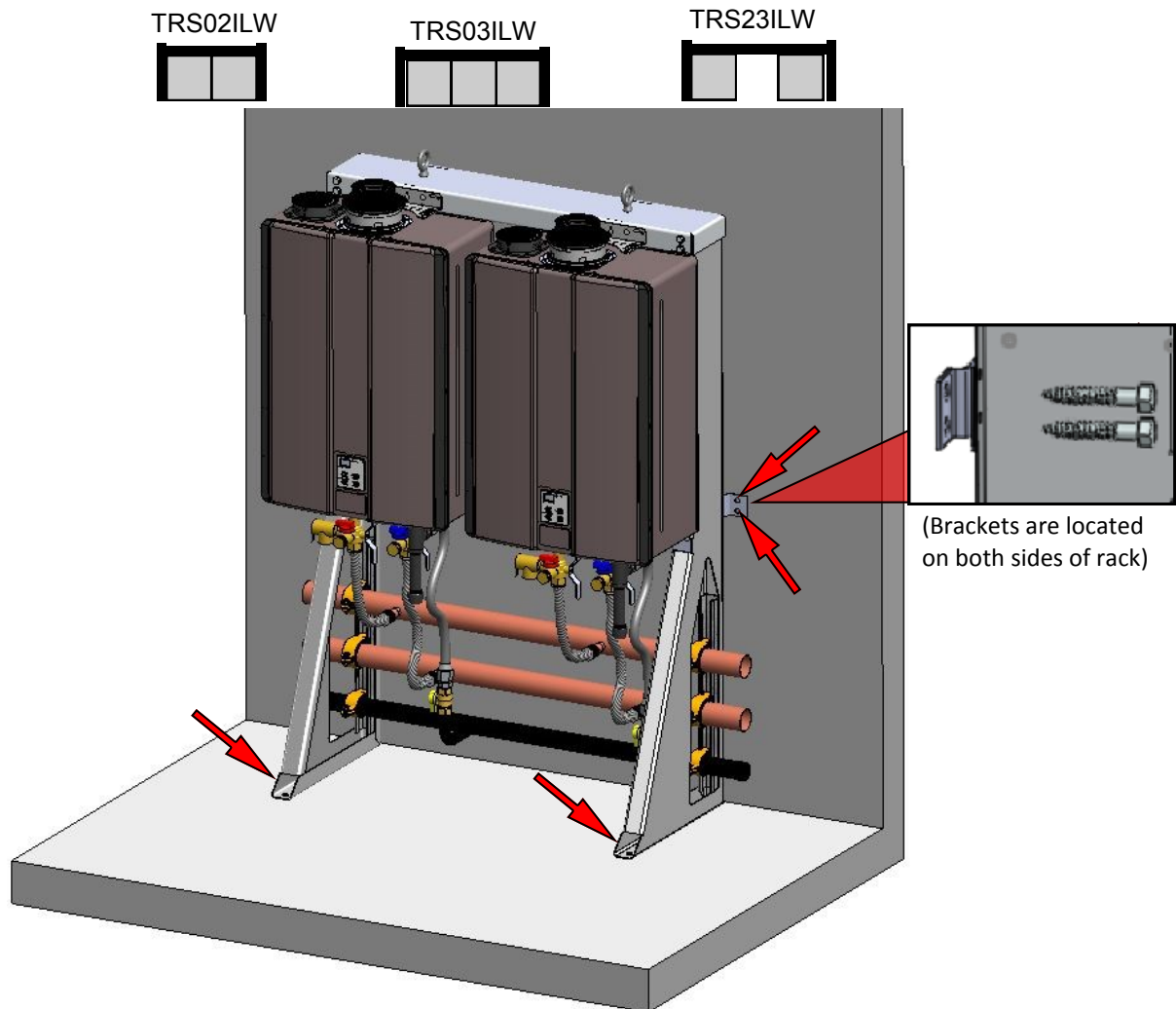

Securing Wall Hanging Racks (TRW)

⚠ WARNING THE WALL MUST BE CAPABLE OF CARRYING THE OPERATING WEIGHT OF THE INSTALLED TRS SYSTEM. CONSULT A STRUCTURAL ENGINEER FOR STRUCTURAL ANALYSIS OF THE WALL AND APPROPRIATE HANGING METHODS BEFORE ATTEMPTING TO HANG THE TRS SYSTEM. FAILURE TO COMPLY WITH THE ABOVE REQUIREMENT COULD RESULT IN SUBSTANTIAL PROPERTY DAMAGE, SEVERE PERSONAL INJURY OR DEATH.

- Identify the installation location and confirm that the installation will meet all required clearances.
- The size and embedment specified are for anchors installed in stone or aggregate concrete only, for other anchorage details the contractor or engineer on record for the building shall consult with a licensed structural engineer for all anchorage of equipment not called out in this manual.
- In the event of a conflict or inconsistency between items indicated in this manual with code requirements, the more stringent standard shall prevail.

WALL HANGING RACK MODELS AVAILABLE

TRW02, TRW03, & TRW23

1. Using the holes in the wall hanging bracket, Securely attach the bracket level to the wall. Ensure that the attachment strength is sufficient.

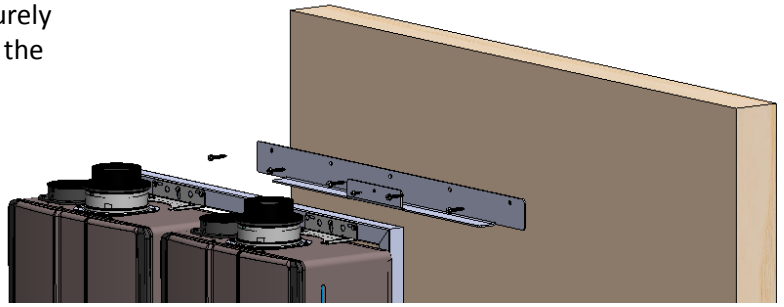

2. Lift the wall hanging rack, and insert the top of the frame into the bracket.

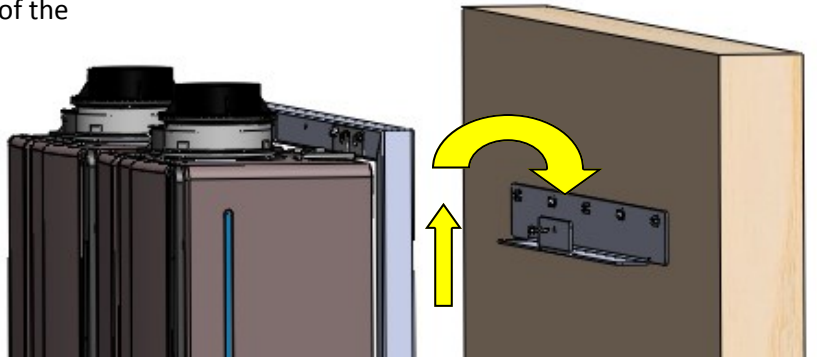

3. Secure the front of the bracket to the front of the wall hanging frame with a #12 X 3/4 drill point screw.

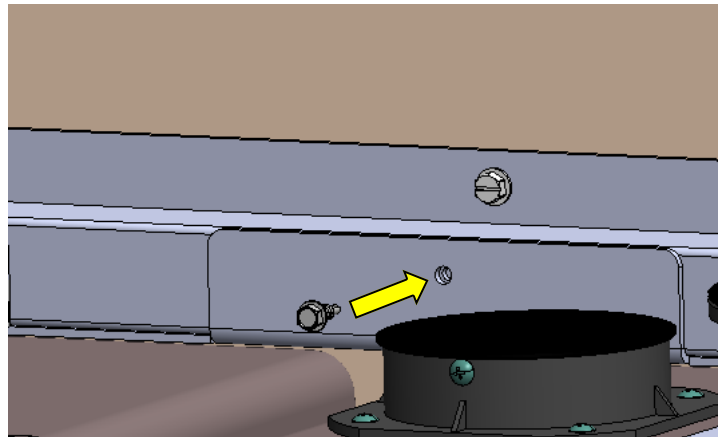

Relief Valve Piping

Each Rinnai tankless water heater on the TRS comes installed with Isolation valves and a pressure relief valve. Refer to the installation and operation manual for more information on proper piping for the relief valve drain.

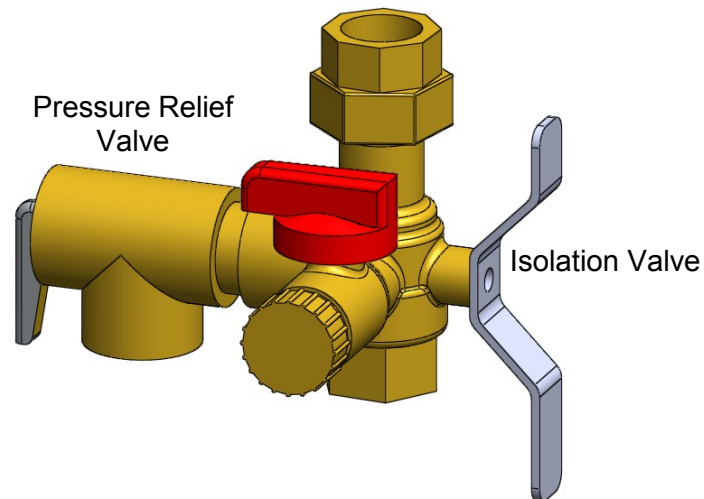

Piping for Multiple Racks

Multiple rack systems should be installed in parallel using a secondary manifold from the building cold and hot water supply. Reference the drawing on the following page for guidance on plumbing multiple racks in a parallel piping system.

A low pressure gas regulator must be installed prior to the rack system. Note the maximum cumulative input for the system when sizing the gas regulator.

Use common plumbing practice and reference all applicable codes when sizing the secondary manifolds and gas regulator.

**Condensing Tankless
Rack Parallel Piping System**

Rack water manifolds
are sized for maximum
water heater flowrate at
4 ft/s velocity

Typical for each rack:
Field supplied end caps.
Refer to rack spec sheet for size.
Must be approved for potable water.

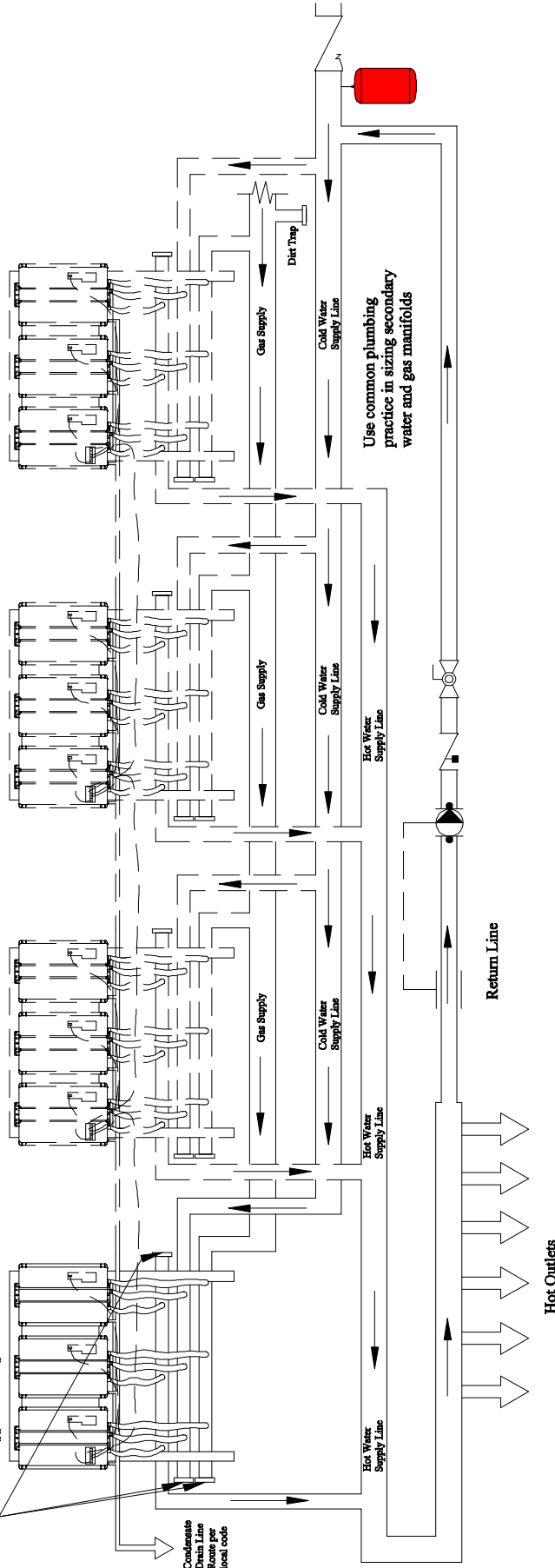

Use common plumbing
practice in sizing secondary
water and gas manifolds

Ghosted units are
potential supplemental
banks of tankless racks

This is not an engineering drawing; it is intended only as a guide and not as a replacement for professional engineering project drawings. This drawing is not intended to describe a complete system. It is up to the contractor or engineer to determine the necessary components and configuration of the particular system to be installed. The drawing does not imply compliance with local building code requirements. It is the responsibility of the engineer or contractor to ensure that the installation is in accordance with all local building codes. Center with local building officials before installation.

Rinnai America Corporation
103 International Drive
Peachtree City, GA 30269
1-800-621-9419
Tolerance
Fraction = $\pm \frac{1}{16}$
XX = ± 0.030
XXX = ± 0.015
XXXX = ± 0.005

This drawing is the exclusive property of Rinnai America Corporation; it may not be reproduced or given to third parties.
Drawn By: DRM
Approved By: RS

Condensing Tankless Rack Parallel Piping System	
SIZE	SCALE
A	NTS
DWG. NO.	RPPS
DATE	07/23/12
REV	D
SHEET 1 of 1	

End Caps / Connections

End caps are to be field supplied and to be of the following materials:

- Cold water cap - Brass or Copper
- Hot water cap - Brass or Copper
- Gas cap - black iron

Once flow direction and gas supply side is determined the other (opposite) side of the manifold must be capped. See the example below.

Leak check the capped ends of the manifolds.

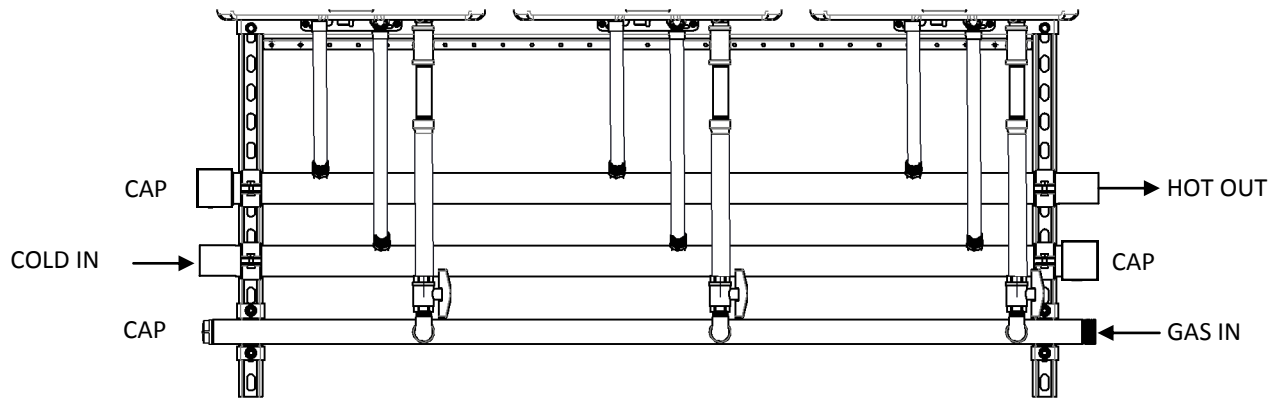

Condensate Drain

Each Rinnai tankless water heater has a condensate drain outlet on the bottom of the unit. A drain line must be connected to each water heater.

Condensate Drain Manifold must be field fabricated (not shown in diagram)

Condensate piping shall be CPVC or PVC material and shall not be smaller than the drain connection on the appliance.

Components of the condensate drainage shall be CPVC or PVC material. All components shall be selected for the pressure and temperature rating of the installation.

Where the drain pipes from more than one unit are manifolded together for condensate drainage, the pipe or tubing shall be sized in accordance with an approved method as dictated by local codes.

Condensate must be disposed of according to local codes.

Piping Diagram for Basic Installation

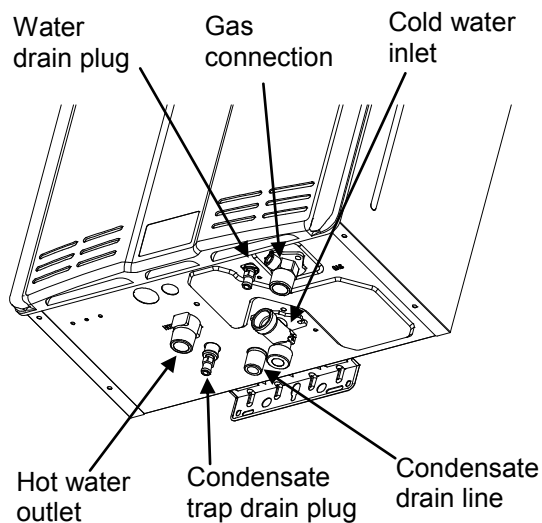

The condensate drain pipe (along its entire length) must be at least the same diameter as the drain line.

Checklist for Plumbing

- Purge the water line of all debris and air by closing the hot isolation valve and opening the cold isolation valve and its drain. **Debris will damage the water heater.** Use a bucket or hose if necessary.
- Ensure that hot and cold water lines are not crossed to the unit and are leak free.
- Ensure that a pressure relief valve is installed with a rating that exceeds the BTU input of the water heater model. Refer to the rating plate on the side of the water heater for BTU input.
- Clean the inlet water filter by closing the cold and hot water inlet isolation (shut-off) valves. Put a bucket under the filter at the bottom of the water heater to catch any water that is contained inside the unit. Unscrew the water filter. Rinse the filter to remove any debris. Install the filter and open the isolation valves.
- Check for proper water pressure to the water heater. Minimum water pressure is 50 psi. Rinnai recommends 60-80 psi for maximum performance.
- Ensure any issues regarding water quality have been properly addressed.

Installation of Gas Supply

! WARNING

1. A licensed professional must install the gas supply.
2. Turn off 120v power supply.
3. Turn off the gas.
4. Gas is flammable. Do not smoke or provide other ignition sources while working with gas.
5. Do not turn on the water heater or gas until all fumes are gone.

MUST DO

- Check the type of gas and the gas inlet pressure before connecting the water heater. If the water heater is not of the gas type that the building is supplied with, DO NOT connect the water heater. Contact the dealer for the proper unit to match the gas type.
- Check the gas supply pressure immediately upstream at a location provided by the gas company. Supplied gas pressure must be within the limits shown in the Specifications section of this manual with all gas appliances operating.
- Before placing the appliance in operation, all joints including the heater must be checked for gas tightness by means of leak detector solution, soap and water, or an equivalent nonflammable solution, as applicable. (Since some leak test solutions, including soap and water, may cause corrosion or stress cracking, the piping shall be rinsed with water after testing, unless it has been determined that the leak test solution is non-corrosive.)
- Use approved connectors to connect the unit to the gas line. Purge the gas line of any debris before connection to the water heater.
- Any compound used on the threaded joint of the gas piping shall be a type that resists the action of liquefied petroleum gas (propane / LPG).
- The gas supply line shall be gas tight, sized, and so installed as to provide a supply of gas sufficient to meet the maximum demand of the heater and all other gas consuming appliances at the location without loss of pressure.

INFORMATION

- If in doubt about the size of the gas line, refer to an approved pipe sizing chart

Connect Electricity

! WARNING

Do not use an extension cord or an adapter plug with this appliance.

The water heater must be electrically grounded in accordance with local codes and ordinances or, in the absence of local codes, in accordance with the National Electrical Code, ANSI/NFPA No. 70.

Indoor water heaters are equipped with a three-prong (grounding) plug for your protection against shock hazard and should be plugged directly into a properly grounded three-prong receptacle. Do not cut or remove the grounding terminal from this plug.

Do not rely on the gas or water piping to ground the water heater. A screw is provided in the junction box for the grounding connection.

The water heater requires 120 VAC, 60 Hz power from a properly grounded circuit.

If using the 5 foot long power cord, plug it into a standard 3 prong 120 VAC, 60 Hz properly grounded wall outlet.

On outdoor models, a disconnect switch must be provided and installed for the incoming 120 VAC power. It should be a type that is suitable for outdoor use. Check the National Electrical Code, ANSI/NFPA 70 and your local codes for a proper switch type to use in your area.

The wiring diagram is located on the Technical Sheet attached to the inside of the front cover.

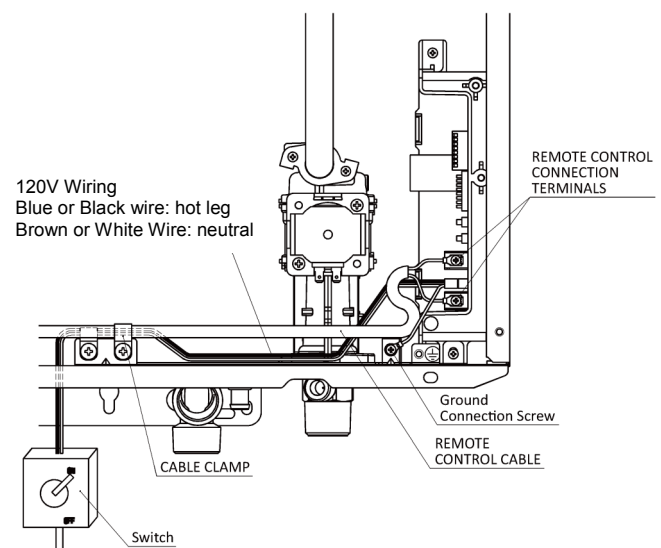

MSB Installation

All of the water heaters should be electronically connected using the MSB control system. The only exception is when a water heater is dedicated to recovering a tank. The MSB kits can electronically connect up to 25 water heaters.

When over 5 water heaters are connected together, MSB-M units are connected using MSB-C2 kits.

If multiple MSB-M are used, then at least three water heaters should be connected to each MSB-M. Example: With 7 water heaters, one MSB-M should control 4 water heaters and the other MSB-M should control 3 water heaters.

The temperature setting for all of the connected water heaters is controlled by the temperature controller connected to the water heater with the master MSB Board. Temperature controllers connected to the other units will provide maintenance codes for their respective units.

On applicable models a single MCC-91 can be connected to the master MSB Board to provide temperatures greater than 140°F for all the water heaters in the MSB system.

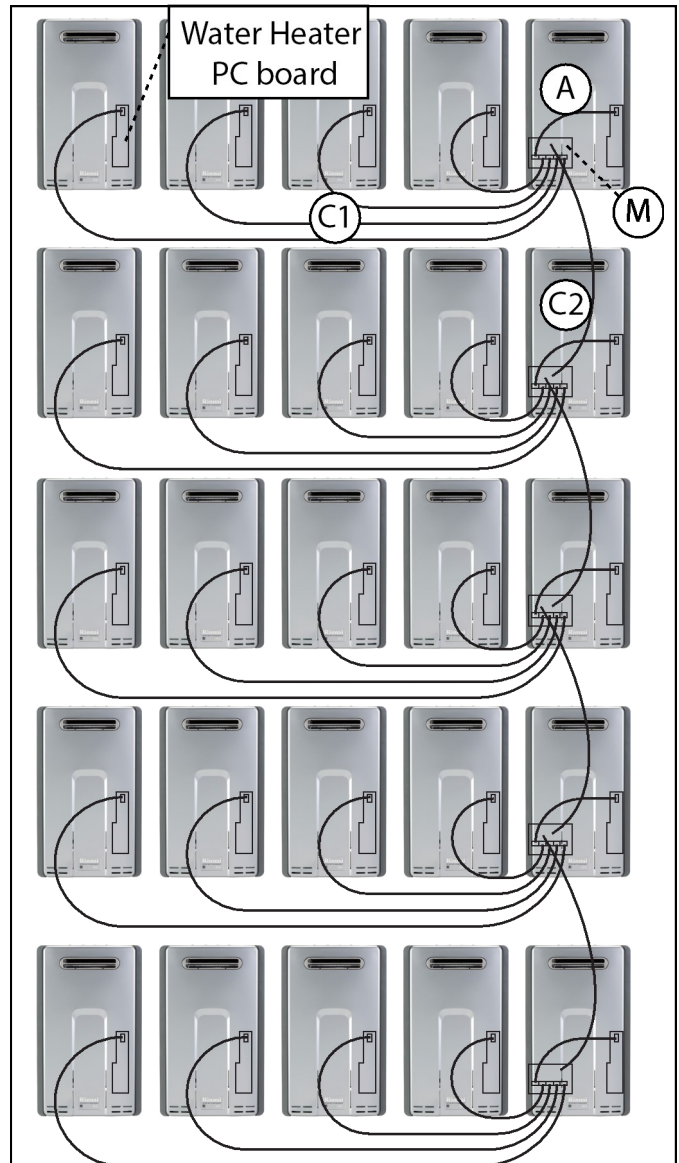

In the diagram above, 25 water heaters are electronically connected. Each bank of 5 is controlled by an MSB-M control board. These boards are connected to each other with MSB-C2 cables. One MSB-M is the controlling or master MSB-M for the entire system.

- (M) MSB-M control board
- (A) Connector cable A (part of MSB-M kit; replace with MSB-C3 cables for V Series)
- (C1) MSB-C1 cable (9.8 feet) for connecting water heaters within a banked system (up to 5), (use MSB-C3 cables for V Series)
- (C2) MSB-C2 cable (26.2 feet) for connecting MSB-M control boards (up to 5)

MSB Installation

1. On the master MSB, one connector is connected to the terminal connector and the other one is connected to the MSB Communication cable.
2. When 2 MSB boards are used a MSB Communication cable will be installed between the master MSB board and the second MSB. The open connector will have the Terminal connector installed on both MSB boards.

A maximum of 5 MSB boards can be connected to each other. The terminal connector is connected on the terminal MSB which has an open connector.

NOTE: When viewing the installed MSB board, the dip switch will be as shown below (upside down).

Master MSB board

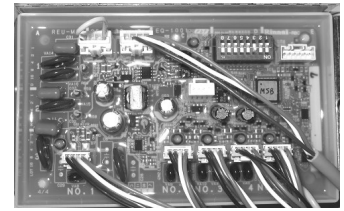

2nd MSB board

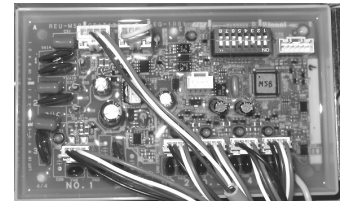

2nd to 4th MSB board

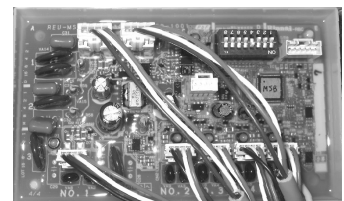

5th or Terminal MSB board

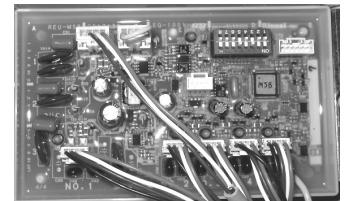

3. Set No 3 switch on the master MSB to ON. The LED light 6 should turn ON confirming the connection.
4. Set No 4 switch on the second MSB to ON. The LED light 6 should turn ON confirming the connection.
5. Set No 3 and No 4 switches on the third MSB board to ON. The LED light 6 should turn ON confirming the connection.
6. Set the No 5 switch on the fourth MSB board to ON. The LED light 6 should turn ON confirming the connection.
7. Set No 3 and No 5 switches on the on the fifth MSB board to ON. The LED light 6 should turn ON confirming the connection.

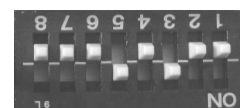
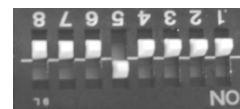
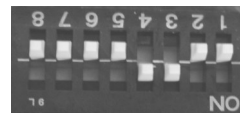
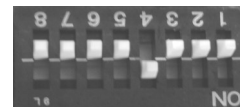
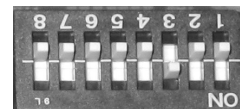

Final Checklist

- The water heater is not subject to corrosive compounds in the air.
- The water supply does not contain chemicals or exceed total hardness that will damage the heat exchanger.
- Clearances from the water heater unit are met.
- Clearances from the vent termination / air intake are met.
- For indoor models, ensure you have used the correct venting products for the model installed and that you have completely followed the venting manufacturer's installation instructions and these installation instructions.
- For indoor models, verify that the vent system does not exceed the maximum length for the number of elbows used.
- For indoor models, verify that SW 1 in DIPSW 1 has been adjusted for vent length if necessary. Refer to the section on Maximum Vent Length.
- Purge the water line of all debris and air by closing the hot isolation valve and opening the cold isolation valve and its drain. **Debris will damage the water heater.** Use a bucket or hose if necessary.
- Ensure that hot and cold water lines are not crossed to the unit and are leak free.
- A manual gas control valve has been placed in the gas line to the water heater.
- Ensure that a pressure relief valve is installed with a rating that exceeds the BTU input of the water heater model. Refer to the rating plate on the side of the water heater for BTU input.
- Clean the inlet water filter by closing the cold and hot water inlet isolation (shut-off) valves. Put a bucket under the filter at the bottom of the water heater to catch any water that is contained inside the unit. Unscrew the water filter. Rinse the filter to remove any debris. Install the filter and open the isolation valves.
- Check the gas lines and connections for leaks.
- Confirm that the gas inlet pressure is within limits.
- Confirm that the water heater is rated for the gas type supplied.
- Confirm that the electricity is supplied from a 120 VAC, 60 Hz power source, is in a properly grounded circuit, and turned on.
- Verify the temperature controller is functioning properly.
- Verify that SW 2 and SW 3 in DIPSW 1 is set correctly for your altitude.
- Verify the system is functioning correctly by connecting your manometer to the gas pressure test port on the water heater. Operate all gas appliances in the home or facility at high fire. The inlet gas pressure at the water heater must not drop below that listed on the rating plate.
- DO NOT** introduce toxic chemicals such as those used for boiler water treatment to the potable water used for space heating.
- If the water heater is not needed for immediate use, then drain the water from the heat exchanger.
- Install the front panel.
- Explain to the customer the importance of not blocking the vent termination or air intake.
- Explain to the customer the operation of the water heater, safety guidelines, maintenance, and warranty.
- The installation must conform with local codes or, in the absence of local codes, with the *National Fuel Gas Code, ANSI Z223.1/NFPA 54*, or the *Natural Gas and Propane Installation Code, CSA B149.1*. If installed in a manufactured home, the installation must conform with the *Manufactured Home Construction and Safety Standard, Title 24 CFR, Part 3280* and/or *CAN/SCA Z240 MH Series, Mobile Homes*.
- Inform the consumer if the isolation valves are not installed or if a water softening system is not installed.
- Leave the entire manual taped to the water heater (indoor models), temperature controller (outdoor models), or give the entire manual directly to the consumer.**

TRS REPLACEMENT PARTS REFERENCE NUMBERS

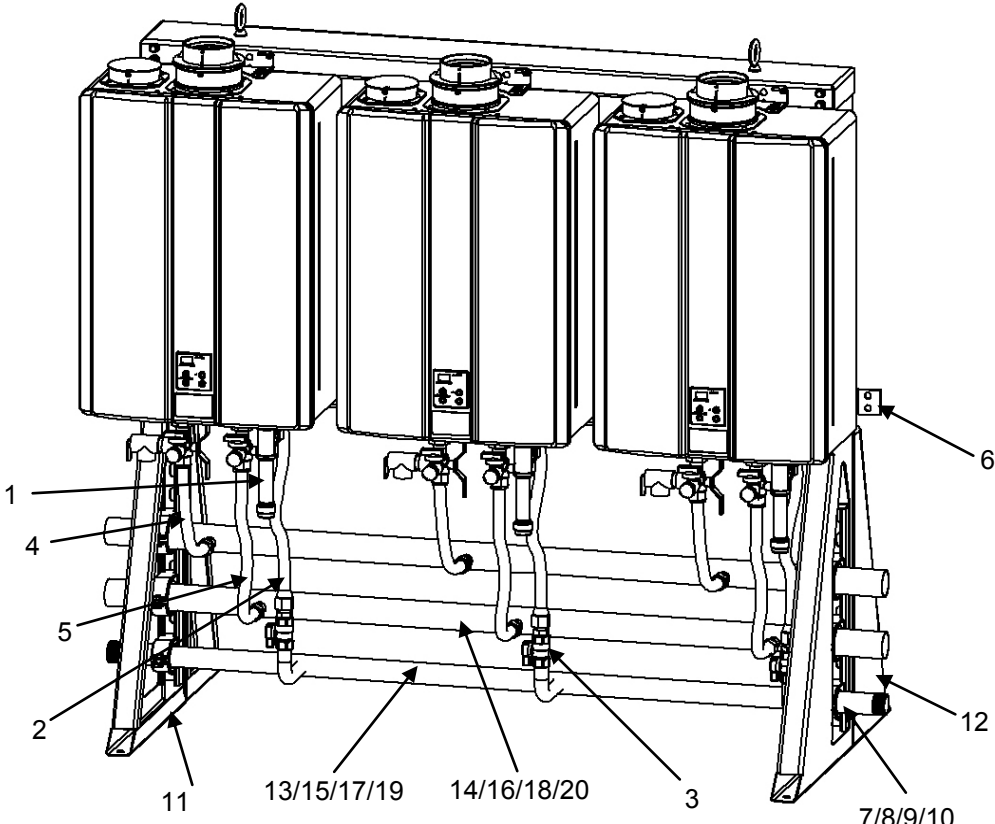

ALL TRS/TRW	
REF. #	Description
1	Dirt Leg
2	Gas Flex Line Assembly
3	Gas Valve
4	Hot Water Flex Line
5	Cold Water Flex Line
6	Wall Bracket
7	Cush Clamp 2.63ID
8	Cush Clamp 2.125ID
9	Cush Clamp 1.90ID
10	Cush Clamp 1.66ID
11	Frame, Rack Left Rear
12	Frame, Rack Right Rear
TRS05/TRS06	
13	Manifold, Gas - 6B2B
14	Manifold, Water - 6B2B
TRS02/TRS03/TRS04	
15	Manifold, Gas - 4B2B
16	Manifold, Water - 4B2B
TRW03/TRS03IL	
17	Manifold, Gas - 3WM
18	Manifold, Water - 3WM
TRW02/TRS02IL	
19	Manifold, Gas - 2WM
20	Manifold, Water - 2WM

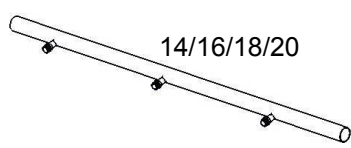
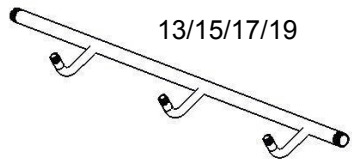
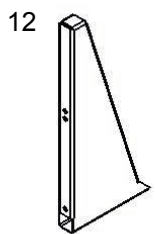
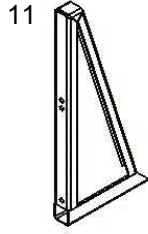
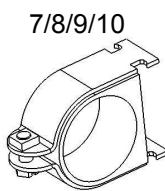
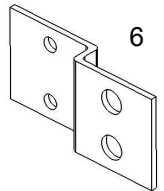
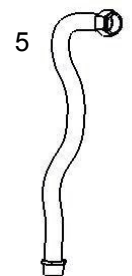
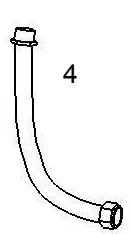
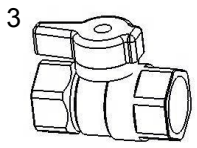
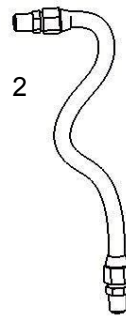
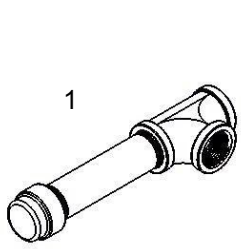

TRW REPLACEMENT PARTS REFERENCE NUMBERS

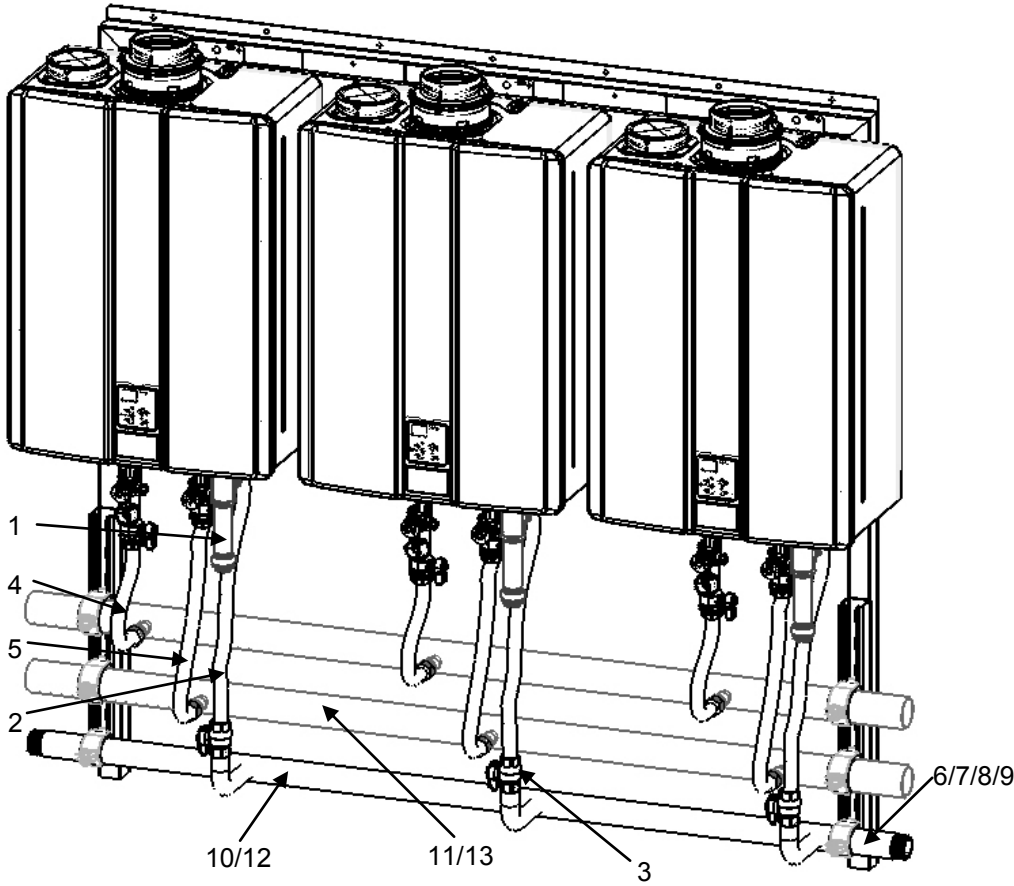

ALL TRW	
REF. #	Description
1	Dirt Leg
2	Gas Flex Line Assembly
3	Gas Valve
4	Hot Water Flex Line
5	Cold Water Flex Line
6	Cush Clamp 2.63ID
7	Cush Clamp 2.125ID
8	Cush Clamp 1.90ID
9	Cush Clamp 1.66ID
TRW03	
10	Manifold, Gas - 3WM
11	Manifold, Water - 3WM
TRW02	
12	Manifold, Gas - 2WM
13	Manifold, Water - 2WM

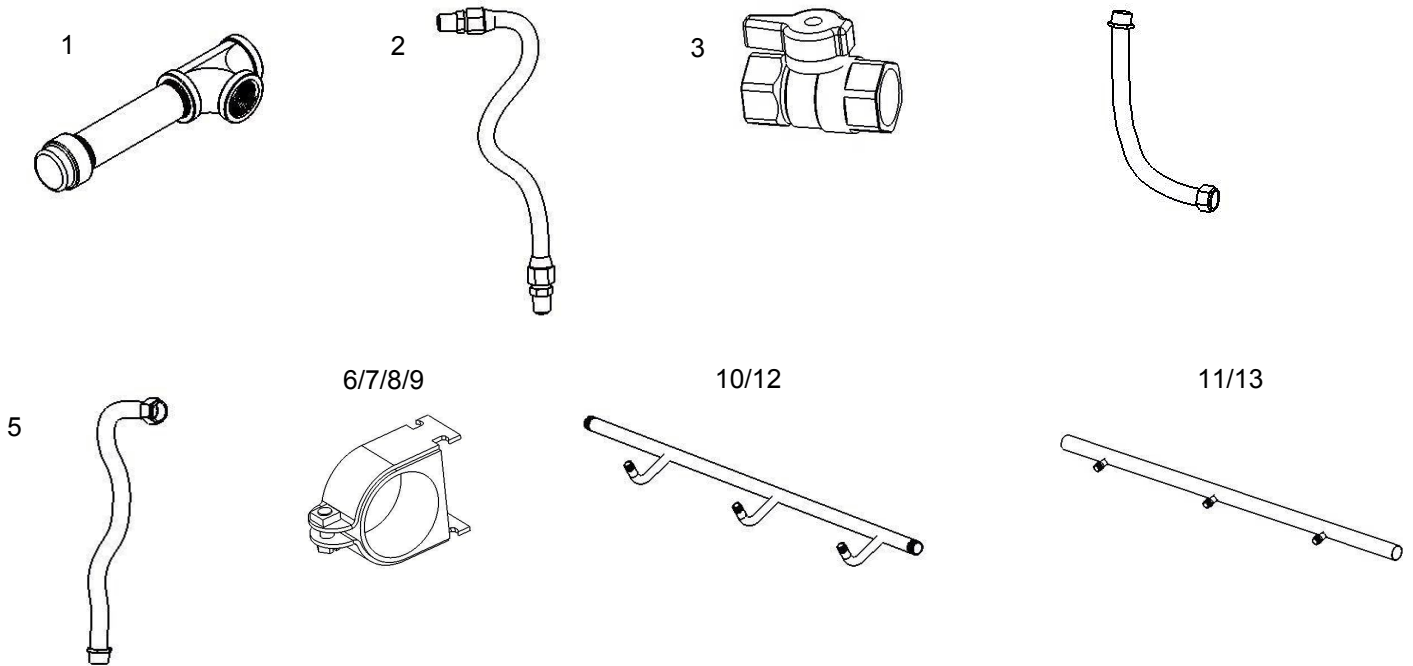

REGISTRATION REQUIRED*

Rinnai is providing the opportunity to extend your Rinnai Standard Limited Warranty for labor only on the tankless water heater product installed as part of the Tankless Rack System and used in a commercial application. You must register the product within 30 days of purchase of the system to qualify.

The limited warranty period on the Labor coverage for Tankless Water Heaters installed on the Tankless Rack System is extended for an additional 12 months (a total of 24 months labor coverage from date of purchase), when registered. **Products not registered will still be covered under the Rinnai standard product limited warranty as provided in the Operating Instruction manual which comes with the Tankless water heater. Warranty information is also available on Rinnai's web site at www.rinnai.us. You can register at www.rinnairegistration.com or by calling 1-866-RINNAI-1 (746-6241), except registration is not required in California and Quebec.**

What is covered?

This Limited Warranty covers any defects in materials or workmanship when the product is installed and operated according to Rinnai written installation instructions, subject to the terms within this Limited Warranty document. This Limited Warranty applies only to products that are installed correctly. Improper installation may void this Limited Warranty. In order for this warranty to apply, it is required that you use a licensed professional who has attended a Rinnai installation training class before installing this water heater. This Limited Warranty extends to the original purchaser and subsequent owners, but only while the product remains at the site of the original installation. This Limited Warranty only extends through the first installation of the product and terminates if the product is moved or reinstalled at a new location.

How long does coverage last?

Item	Period of Coverage (from date of purchase)		
	Labor	Parts	Heat Exchanger
Tankless Water Heaters	1 year (2)	5 years (1)	5 years (1)
Rack and Components		1 year	

Only applicable if product is registered within 30 days of purchase and the other conditions are met. Note to California and Quebec Residents, and residents of other jurisdictions that prohibit warranty benefits conditioned on registration, registration is not required to obtain longer warranty periods and failure to register does not diminish your warranty rights. www.rinnai.us/warranty

[1] The warranty period is reduced to 3 years from date of purchase when the water heater is used as a circulating water heater within a hot water circulation loop, where the water heater is in series with a circulation system and all circulating water flows through the water heater, and where an on-demand recirculation system is not incorporated.

On-demand recirculation is defined as a hot water recirculating loop or system that utilizes existing hot and cold lines or a dedicated return line, and only activates when hot water is used. It can be activated by a push button, motion sensor, or voice activation but not by a temperature sensor. A timer added to a standard recirculating pump is not considered as on-demand.

[2] Labor coverage is extended to 5 years in residential applications and to 2 years in commercial applications if the product is registered within 30 days (except registration is not required in California and Quebec) and/or if the other conditions above in the Residential Applications and Commercial Applications sections are satisfied.

What will Rinnai do?

Rinnai will repair or replace the covered product or any part or component that is defective in materials or workmanship as set forth. Rinnai will pay reasonable labor charges associated with the repair or replacement of any part or component of the tankless water heater. All repair parts must be genuine Rinnai parts. All repairs or replacements must be performed by a licensed professional that is properly trained, state qualified or licensed to do the type of repair.

Replacement of the product may be authorized by Rinnai only. Rinnai does not authorize any person or company to assume for it any obligation or liability in connection with the replacement of the product. If Rinnai determines that repair of a product is not possible, Rinnai will replace the product with a comparable product at Rinnai's discretion. The warranty claim for product parts and labor may be denied if a component or product returned to Rinnai is found to be free of defects in material or workmanship; damaged by improper installation, use or operation; or damaged during return shipping.

How do I get service?

You must contact a licensed professional for the repair of a product under this Limited Warranty. For the name of a licensed professional please contact your place of purchase, visit the Rinnai website (www.rinnai.us), call Rinnai at 1-800-621-9419 or write to Rinnai at 103 International Drive, Peachtree City, Georgia 30269.

Proof of purchase is required to obtain warranty service. You may show proof of purchase with a dated sales receipt, or by registering within 30 days of purchasing the product. To register your tankless water heater, please visit www.rinnai.us. For those without internet access, please call 1-866-RINNAI1 (746-6241). Receipt of Registration by Rinnai will constitute proof-of-purchase for this product. However, Registration is not necessary in order to validate this Limited Warranty.

What is not covered?

This Limited Warranty does not cover any failures or operating difficulties due to the following:

- accident, abuse, or misuse
- alteration of the product or any component part
- misapplication of this product
- improper installation (such as but not limited to)
 - ◇ Product being installed in a corrosive environment
 - ◇ condensate damage
 - ◇ improper venting
 - ◇ incorrect gas type
 - ◇ incorrect gas or water pressure
 - ◇ absence of a drain pan under the appliance
- water quality
- improper maintenance (such as but not limited to scale build-up, freeze damage, or vent blockage)
- incorrect sizing
- any other cause not due to defects in materials or workmanship
- Problems or damage due to fires, flooding, electrical surges, freezing or any acts of God.
- force majeure

There is no warranty coverage on product installed in a closed loop application, commonly associated with space heating only applications.

The integrated controller on indoor models has a 1 year warranty on parts.

This Limited Warranty does not apply to any product whose serial number or manufacture date has been defaced. This Limited Warranty does not cover any product used in an application that uses chemically treated water such as a pool or spa heater. This appliance is suitable for filling large or whirlpool bath tubs with potable water.

Limitation on warranties

No one is authorized to make any other warranties on behalf of Rinnai America Corporation. Except as expressly provided herein, there are no other warranties, expressed or implied, including, but not limited to warranties of merchantability or fitness for a particular purpose, which extend beyond the description of the warranty herein and further Rinnai shall not be liable for indirect, incidental, special, consequential or other similar damages that may arise, including lost profits, damage to person or property, loss of use, inconvenience, or liability arising from improper installation, service or use. Some states do not allow the exclusion or limitation of incidental or consequential damages, so the above limitation may not apply to you.

Any implied warranties of merchantability and fitness arising under state law are limited in duration to the period of coverage provided by this Limited Warranty, unless the period provided by state law is less. Some states do not allow limitations on how long an implied Limited Warranty lasts, so the above limitation may not apply to you.

This Limited Warranty gives you specific legal rights, and you may also have other rights which vary from state to state.

www.rinnai.us/warranty

A tradition of

TRUE RELIABILITY.

For nearly 100 years, we at Rinnai have been fiercely committed to delivering nothing less than a superior experience at every touch point.

Beyond manufacturing the highest quality products, our people stand behind all that we make—before, during and long after installation. From the 24/7/365 technical support for professionals, to our national network of independent installers for homeowners, to on-staff engineers who can assist with choosing the right products and sizes—we're inspiring confidence right along with the comfort our solutions provide.



Learn more about Rinnai high-performance Tankless Water Heaters, Hybrid Tank-Tankless Water Heaters, Boilers, Vent-Free Fan Convectors and Direct Vent Wall Furnaces at www.rinnai.us

Rinnai®

Rinnai America Corporation • 103 International Drive, Peachtree City, GA 30269

Toll-Free: 1-800-621-9419 • Phone: 678-829-1700 • www.rinnai.us

©2014 Rinnai America Corporation. Rinnai is continually updating and improving products; therefore, specifications are subject to change without prior notice. Local, state, provincial, federal and national fuel gas codes must be adhered to prior to and upon installation.

10000294(06)
6/2015