



**Introduction** Pgs 1-13  
*Selecting the right product*

**KlassikDrain** Pgs 14-33, 54-61  
*General purpose trench drain*  
**Part 1** - K100, K50 & Brickslot

**KlassikDrain** Pgs 34-53  
*General purpose trench drain*  
**Part 2** - K200/K300

**PowerDrain** Pgs 62-95  
*Heavy duty trench drain*

**Slab Solutions** Pgs 96-123  
*Trench drain for concrete slabs*

**Design Services & Support** Pgs 124-159



**Note:** This electronic file is part of a larger 160 page Technical Handbook. Please contact ACO at 1-800-543-4764 for a copy.



## ACO DRAIN

*Commercial trench drainage  
Technical handbook & product catalog*

### **PowerDrain Section** **S100K/S200K/S300K**





SIEMENS

SIEMENS

BECK'S

JAGUAR

HSBC



Castrol

EDS

AT&T

MICHELIN



**PowerDrain**  
Heavy duty trench drain

S100K .....	66
S200K .....	76
S300K .....	86

## PowerDrain features



**Ductile iron grates** - Heavy duty ductile iron grates in choice of ADA compliant (Load Class E\*) or slotted (Load Class F. (\*S100K ADA grates rated to Load Class F).

**Ductile iron edge rail** - Integrally cast-in rail provides maximum strength and protection for channel body. Shock absorbing widgets, with M10 stainless steel threads, fitted in rail to assist grate fit and aid hanging installation.

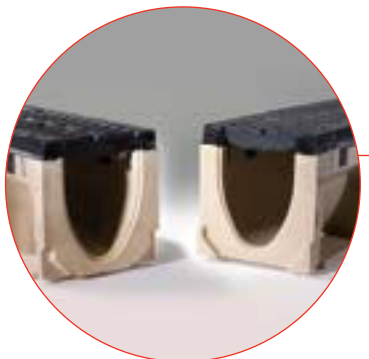

**Interconnecting end profiles** - Allow easy and effective joining of channels. Appropriate sealant can be used to create sealed joint.

**PowerLok™** - A patented, boltless locking system that provides quick fitting and removal of grates. Helps reduce installation/maintenance time and cost.



**S300K** 12" internal width

**Polymer concrete** - Durable, yet lightweight material made from polyester resin binder reinforced by mineral aggregates and fillers. Provides up to four times the compressive strength of cement concrete. See page 136 for material properties.

**System numbering** - Each end of channel indicates number of appropriate sloped channel that connects to it.



**Channel identification** - Channels feature numbering on sidewalls. Numbering in base of channel allows easy identification after concrete encasement.

**S200K** 8" internal width

**Knock-outs** - Included on all channel units to allow vertical evacuation of the system along the run. See product pages for sizes for each system.

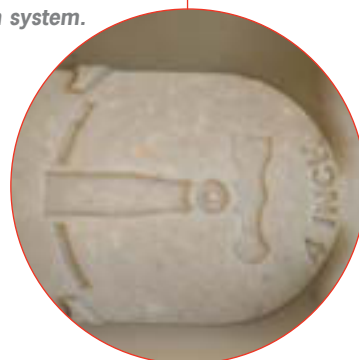

**Direction arrows** - Cast on side of channel indicate flow direction and ensure channels are installed correctly.

**S100K** 4" internal width

**Sloped (0.5%) channel units** - Meter long units provide 131'-3" continuous slope - equates to 1/17" fall per linear foot. Constant depth units can be used to extend run lengths.

**Anti-shunt lugs** - Recesses in grate fit around lugs on edge rail to prevent longitudinal movement.

**4-Bolt slotted grate** - 4-bolt grate option is available on all widths to provide maximum security and stability for super heavy duty applications.

**Profiled side walls** - Strengthening pillars and frost keys provide channel body strength and mechanical keying to surrounding concrete.

**Shipping gipple/groove** - Side interlocking feature ensures safer stacking of channels on pallets for shipping to minimize breakage.

**Concrete anchor boss** - A drill-through hole in the ductile iron rail enables a concrete anchor (4 per meter) to be attached for extra embedment into concrete haunch.





**S100K** - 4" wide heavy duty system



S100K is a 4" wide system with choice of Class F (90 ton) slotted or ADA compliant ductile iron grates featuring PowerLok™ patented boltless locking system. A 4-bolt slotted grate is also available.



**PowerDrain S100K**

**Key Dimensions**

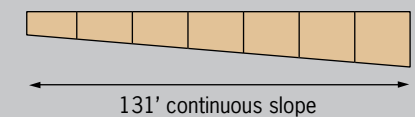
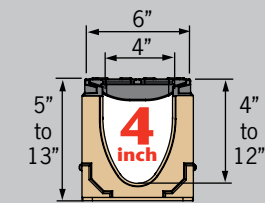

**Typical applications**

- Airports
- Highways
- Heavy duty industrial areas
- Gas stations
- Docks & ports
- Military bases
- Truck stops

**Selection criteria**

**A B C D E F** Light to heavy industrial duty loads

Product can be used towards LEED & EPA requirements

Resistant to many everyday chemicals. *Check page 139*

Multiple grate options to meet legal requirements

Multiple grate options to meet design requirements

General everyday hydraulic capacity

Constant depth and/or sloped depth channels

System layout

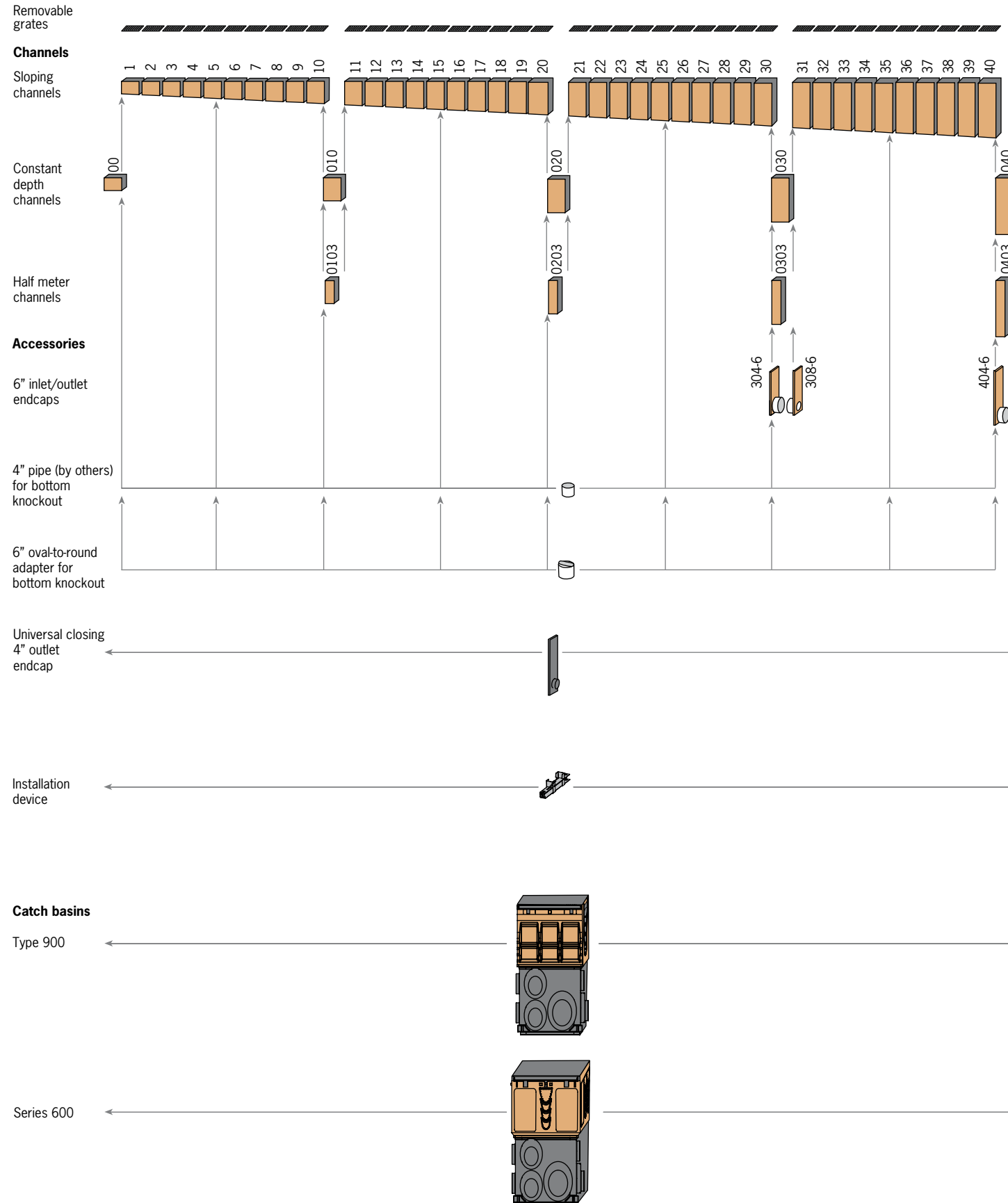

Meter channels - sloping & constant depth

0.5% sloped channels with ductile iron edge rail, in meter lengths and 40 depths to create a 40 meter (131'-2") continuously sloping run.



Constant depth channels are available in 5 depths. Can be used to create non-sloped runs, or inserted in sloped runs to increase length.

Bottom knockouts on all constant depths and 5, 10, 15, 20, 25, 30, 35, 40 channels.

Half meter channels

Constant depth channels with ductile iron edge rail, in 4 depths supplement meter channels. Side knockout and profiling enable side junction to be created. Bottom knockouts on all half meter channels.



6 in. Sch 40 inlet/outlet caps

6" Schedule 40 plain end polypropylene pipe; oval to round adapter cast into polymer concrete end cap and available in two heights. Solvent weld to coupler. **Note:** These end caps cannot be cut to height, and fit only at positions shown in layout diagram.

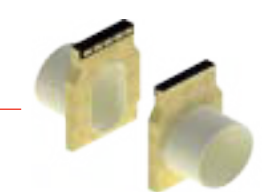

Closing/4 in. inlet/outlet cap

Fits all channels, manufactured from black ABS to complement edge rail. Guides aid cutting to correct height. Wings clip cap onto end of channel. 4" bell end connection to Schedule 40 pipe. Seal using PVC-ABS cement.

**Note:** For depth 1-10 channels, ACO recommends removal of unused sections of bell end to ensure adequate pavement material coverage.



Installation device

Fits molded recesses on body of channel. Provides height and joint alignment - a sliding clamp locks the two channels together. Bolt to rebar on either side of channel to hold channels in place during concrete pour. Not reusable; it is 'lost' within concrete haunch.



Type 901D In-line catch basin

Two part in-line catch basin with 4", 6" and 8" drill-outs for pipe connection. Supplied with with ductile iron edge rail and plastic trash bucket. Options include an in-line or side foul air trap.



Any channel can be connected into the catch basin by removing the end wall to the correct height with a box cutter. Cut-out guides provided for connection to channels 00, 010, 020, 030 and 040. All cut-outs to receive male channel ends. One blanking end plate supplied with in-line catch basin.

Series 600D catch basin

Two part in-line catch basin; bases have 4", 6" and 8" drill-outs for pipe connections. Supplied with with ductile iron edge rail and plastic trash bucket. Optional riser available for increased depth. Contact ACO for non-polyethylene riser/bases.

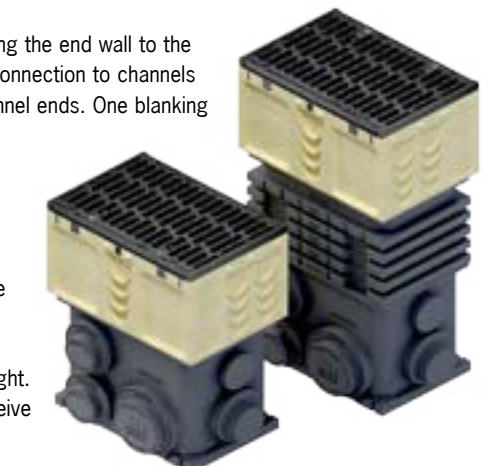

Any channel can be connected to catch basin by removing end/side wall to correct height. Drill-outs guide connection to channels 00, 010, 020, 030 and 040. All cut-outs to receive male channel ends.

# ACO DRAIN

# PowerDrain S100K

## Product dimensions

### Meter channels

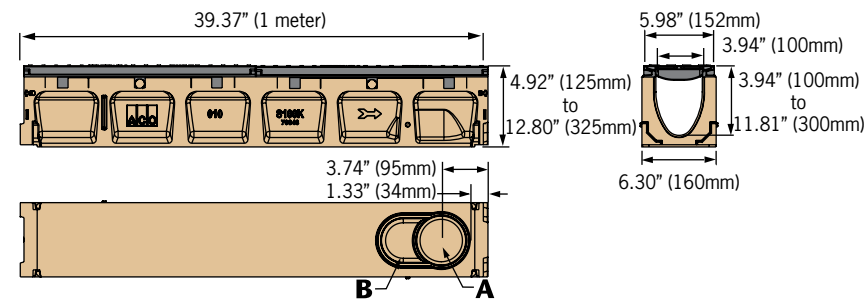

### Half meter channels

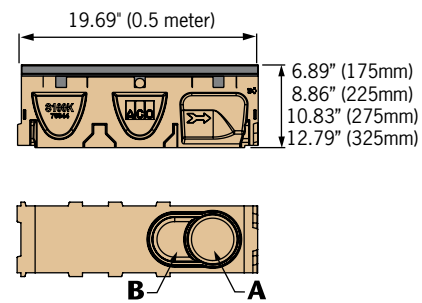

### 6 in. Sch. 40 inlet/outlet caps

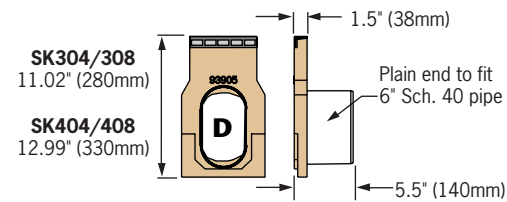

### Closing/4 in. inlet/outlet cap

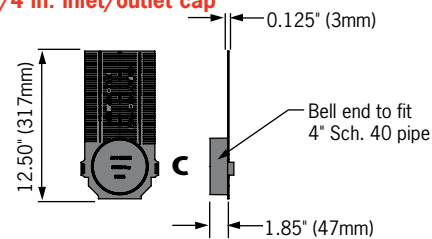

### Installation device

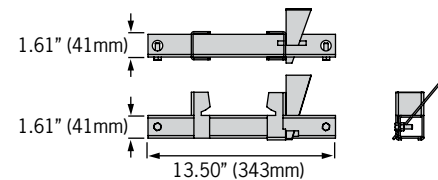

### SK1-901D In-line catch basin

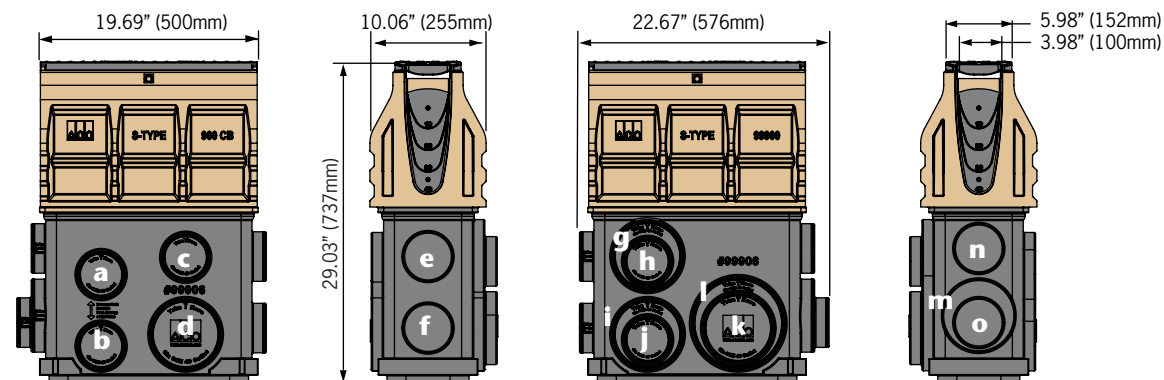

## Outlet flow rates

Channels		Invert in.	GPM	CFS
A	SK1-00 - 4" round	3.94"	108	0.24
A	SK1-40 - 4" round	11.81"	187	0.42
B	SK1-00 - 6" oval	3.94"	177	0.39
B	SK1-40 - 6" oval	11.81"	306	0.68
C	SK1-20 - 4" round	7.87"	132	0.29
C	SK1-40 - 4" round	11.81"	171	0.38
D	SK1-30 - 6" oval	9.84"	233	0.52
D	SK1-40 - 6" oval	11.81"	264	0.59

Catch basins		SK1-901D			SK1-621D			SK1-631D		
Outlet	Size (Sch 40)	Invert in.	GPM	CFS	Invert in.	GPM	CFS	Invert in.	GPM	CFS
a	4" round	20.68"	235	0.52	21.29"	239	0.53	33.29"	305	0.68
b	4" round	27.17"	273	0.61	27.79"	276	0.62	39.79"	335	0.75
c	4" round	18.99"	224	0.50	19.72"	229	0.51	31.72"	297	0.66
d	6" round	27.17"	602	1.34	27.79"	610	1.36	39.79"	743	1.66
e	4" round	19.30"	226	0.50	19.84"	230	0.51	31.84"	297	0.66
f	4" round	25.67"	265	0.59	26.34"	269	0.60	38.34"	328	0.73
g	6" round	19.99"	505	1.12	20.62"	514	1.15	32.62"	667	1.49
h	4" round	19.36"	227	0.51	20.07"	231	0.52	32.07"	299	0.67
i	6" round	27.30"	604	1.35	27.76"	609	1.36	39.76"	743	1.65
j	4" round	26.43"	269	0.60	27.19"	273	0.61	39.19"	332	0.74
k	6" round	26.43"	593	1.32	27.19"	602	1.34	39.19"	737	1.64
l	8" round	27.30"	1051	2.34	27.76"	1061	2.36	39.76"	1302	2.90
m	6" round	25.85"	586	1.30	26.28"	591	1.32	38.28"	728	1.62
n	4" round	18.56"	222	0.49	19.15"	225	0.50	31.15"	294	0.65
o	4" round	25.30"	263	0.59	25.86"	266	0.59	37.86"	326	0.73

Note: These are pipe flow rates at specified outlet, NOT channel flow rates. Catch basin flow rates without trash bucket - using trash bucket reduces flow.

### SK1-621D catch basin

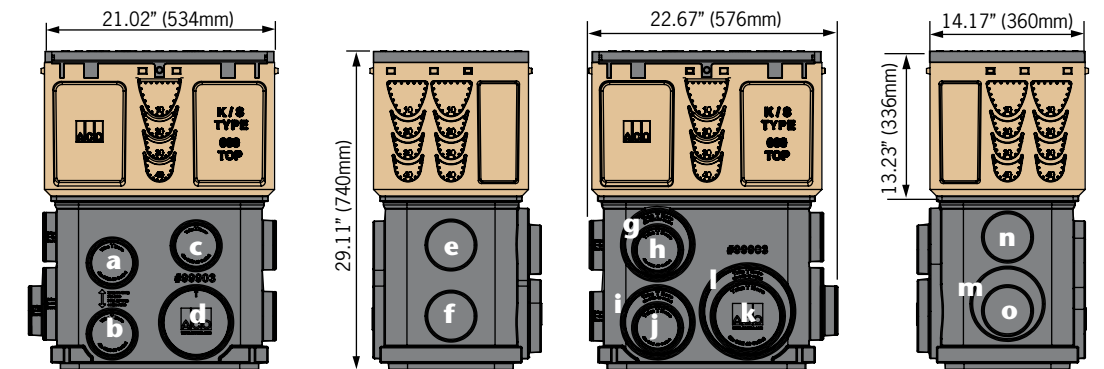

### SK1-631D catch basin

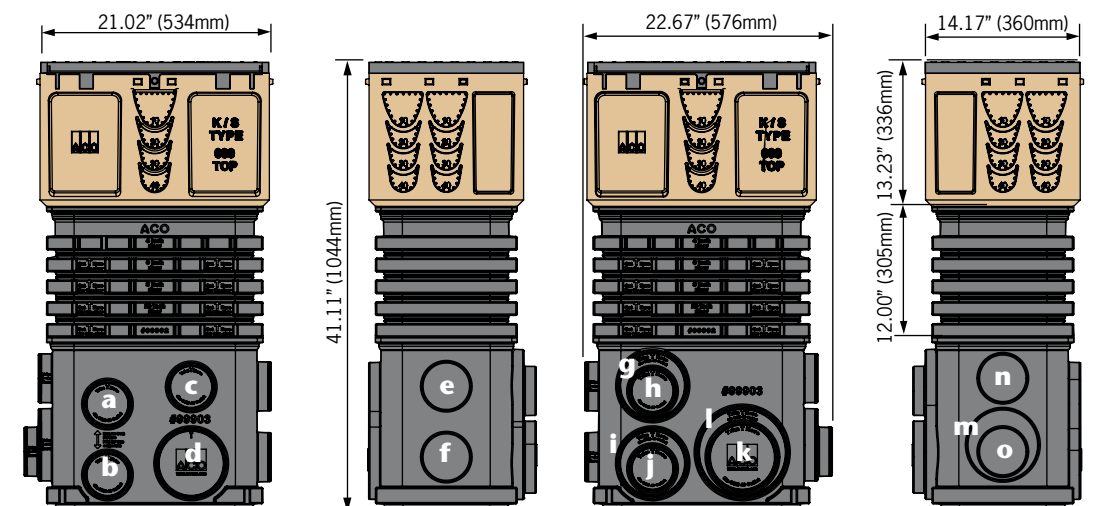

S100K Parts table

	Part No.	Invert Depth				Overall Depth				Vol Gal	Wgt lbs
		Inches		mm		Inches		mm			
		female	male	female	male	female	male	female	male		
<b>SK1-00 Constant depth channel - 39.37" (1m) <sup>2</sup></b>	<b>67041</b>	<b>3.94</b>	<b>3.94</b>	<b>100</b>	<b>100</b>	<b>4.92</b>	<b>4.92</b>	<b>125</b>	<b>125</b>	<b>1.96</b>	<b>48.1</b>
SK1-1 Sloped channel - 39.37" (1m)	67001	3.94	4.13	100	105	4.92	5.12	125	130	1.99	48.1
SK1-2 Sloped channel - 39.37" (1m)	67002	4.13	4.33	105	110	5.12	5.31	130	135	2.04	49.1
SK1-3 Sloped channel - 39.37" (1m)	67003	4.33	4.53	110	115	5.31	5.51	135	140	2.13	50.1
SK1-4 Sloped channel - 39.37" (1m)	67004	4.53	4.72	115	120	5.51	5.71	140	145	2.23	51.1
SK1-5 Sloped channel - 39.37" (1m) <sup>2</sup>	67005	4.72	4.92	120	125	5.71	5.91	145	150	2.33	52.1
SK1-6 Sloped channel - 39.37" (1m)	67006	4.92	5.12	125	130	5.91	6.10	150	155	2.43	53.1
SK1-7 Sloped channel - 39.37" (1m)	67007	5.12	5.31	130	135	6.10	6.30	155	160	2.54	54.1
SK1-8 Sloped channel - 39.37" (1m)	67008	5.31	5.51	135	140	6.30	6.50	160	165	2.65	55.1
SK1-9 Sloped channel - 39.37" (1m)	67009	5.51	5.71	140	145	6.50	6.69	165	170	2.75	56.1
SK1-10 Sloped channel - 39.37" (1m) <sup>2</sup>	67010	5.71	5.91	145	150	6.69	6.89	170	175	2.86	57.1
<b>SK1-010 Constant depth channel - 39.37" (1m) <sup>2</sup></b>	<b>67043</b>	<b>5.91</b>	<b>5.91</b>	<b>150</b>	<b>150</b>	<b>6.89</b>	<b>6.89</b>	<b>175</b>	<b>175</b>	<b>2.85</b>	<b>57.1</b>
<b>SK1-0103 Constant depth channel - 19.69" (0.5m) <sup>2</sup></b>	<b>67044</b>	<b>5.91</b>	<b>5.91</b>	<b>150</b>	<b>150</b>	<b>6.89</b>	<b>6.89</b>	<b>175</b>	<b>175</b>	<b>1.43</b>	<b>29.4</b>
SK1-11 Sloped channel - 39.37" (1m)	67011	5.91	6.10	150	155	6.89	7.09	175	180	2.97	58.1
SK1-12 Sloped channel - 39.37" (1m)	67012	6.10	6.30	155	160	7.09	7.28	180	185	3.08	59.1
SK1-13 Sloped channel - 39.37" (1m)	67013	6.30	6.50	160	165	7.28	7.48	185	190	3.19	60.1
SK1-14 Sloped channel - 39.37" (1m)	67014	6.50	6.69	165	170	7.48	7.68	190	195	3.30	61.1
SK1-15 Sloped channel - 39.37" (1m) <sup>2</sup>	67015	6.69	6.89	170	175	7.68	7.87	195	200	3.42	62.1
SK1-16 Sloped channel - 39.37" (1m)	67016	6.89	7.09	175	180	7.87	8.07	200	205	3.53	63.1
SK1-17 Sloped channel - 39.37" (1m)	67017	7.09	7.28	180	185	8.07	8.27	205	210	3.64	64.1
SK1-18 Sloped channel - 39.37" (1m)	67018	7.28	7.48	185	190	8.27	8.46	210	215	3.75	65.1
SK1-19 Sloped channel - 39.37" (1m)	67019	7.48	7.68	190	195	8.46	8.66	215	220	3.86	66.1
SK1-20 Sloped channel - 39.37" (1m) <sup>2</sup>	67020	7.68	7.87	195	200	8.66	8.86	220	225	3.98	67.1
<b>SK1-020 Constant depth channel - 39.37" (1m) <sup>2</sup></b>	<b>67045</b>	<b>7.87</b>	<b>7.87</b>	<b>200</b>	<b>200</b>	<b>8.86</b>	<b>8.86</b>	<b>225</b>	<b>225</b>	<b>3.97</b>	<b>67.1</b>
<b>SK1-0203 Constant depth channel - 19.69" (0.5m) <sup>2</sup></b>	<b>67046</b>	<b>7.87</b>	<b>7.87</b>	<b>200</b>	<b>200</b>	<b>8.86</b>	<b>8.86</b>	<b>225</b>	<b>225</b>	<b>1.98</b>	<b>33.9</b>
SK1-21 Sloped channel - 39.37" (1m)	67021	7.87	8.07	200	205	8.86	9.06	225	230	4.09	68.1
SK1-22 Sloped channel - 39.37" (1m)	67022	8.07	8.27	205	210	9.06	9.25	230	235	4.20	69.1
SK1-23 Sloped channel - 39.37" (1m)	67023	8.27	8.46	210	215	9.25	9.45	235	240	4.32	70.0
SK1-24 Sloped channel - 39.37" (1m)	67024	8.46	8.66	215	220	9.45	9.65	240	245	4.42	71.0
SK1-25 Sloped channel - 39.37" (1m) <sup>2</sup>	67025	8.66	8.86	220	225	9.65	9.84	245	250	4.54	72.0
SK1-26 Sloped channel - 39.37" (1m)	67026	8.86	9.06	225	230	9.84	10.04	250	255	4.66	73.0
SK1-27 Sloped channel - 39.37" (1m)	67027	9.06	9.25	230	235	10.04	10.24	255	260	4.78	74.0
SK1-28 Sloped channel - 39.37" (1m)	67028	9.25	9.45	235	240	10.24	10.43	260	265	4.89	75.0
SK1-29 Sloped channel - 39.37" (1m)	67029	9.45	9.65	240	245	10.43	10.63	265	270	5.00	76.0
SK1-30 Sloped channel - 39.37" (1m) <sup>2</sup>	67030	9.65	9.84	245	250	10.63	10.83	270	275	5.11	77.0
<b>SK1-030 Constant depth channel - 39.37" (1m) <sup>2</sup></b>	<b>67047</b>	<b>9.84</b>	<b>9.84</b>	<b>250</b>	<b>250</b>	<b>10.83</b>	<b>10.83</b>	<b>275</b>	<b>275</b>	<b>5.10</b>	<b>77.0</b>
<b>SK1-0303 Constant depth channel - 19.69" (0.5m) <sup>2</sup></b>	<b>67048</b>	<b>9.84</b>	<b>9.84</b>	<b>250</b>	<b>250</b>	<b>10.83</b>	<b>10.83</b>	<b>275</b>	<b>275</b>	<b>2.55</b>	<b>38.4</b>
SK1-31 Sloped channel - 39.37" (1m)	67031	9.84	10.04	250	255	10.83	11.02	275	280	5.23	78.0
SK1-32 Sloped channel - 39.37" (1m)	67032	10.04	10.24	255	260	11.02	11.22	280	285	5.34	79.0
SK1-33 Sloped channel - 39.37" (1m)	67033	10.24	10.43	260	265	11.22	11.42	285	290	5.45	80.0
SK1-34 Sloped channel - 39.37" (1m)	67034	10.43	10.63	265	270	11.42	11.61	290	295	5.56	81.0
SK1-35 Sloped channel - 39.37" (1m) <sup>2</sup>	67035	10.63	10.83	270	275	11.61	11.81	295	300	5.68	82.0
SK1-36 Sloped channel - 39.37" (1m)	67036	10.83	11.02	275	280	11.81	12.01	300	305	5.79	83.0
SK1-37 Sloped channel - 39.37" (1m)	67037	11.02	11.22	280	285	12.01	12.20	305	310	5.91	84.0
SK1-38 Sloped channel - 39.37" (1m)	67038	11.22	11.42	285	290	12.20	12.40	310	315	6.02	85.0
SK1-39 Sloped channel - 39.37" (1m)	67039	11.42	11.61	290	295	12.40	12.60	315	320	6.13	86.0
SK1-40 Sloped channel - 39.37" (1m) <sup>2</sup>	67040	11.61	11.81	295	300	12.60	12.8	320	325	6.25	87.0
<b>SK1-040 Constant depth channel - 39.37" (1m) <sup>2</sup></b>	<b>67049</b>	<b>11.81</b>	<b>11.81</b>	<b>300</b>	<b>300</b>	<b>12.80</b>	<b>12.80</b>	<b>325</b>	<b>325</b>	<b>6.24</b>	<b>87.0</b>
<b>SK1-0403 Constant depth channel - 19.69" (0.5m) <sup>2</sup></b>	<b>67050</b>	<b>11.81</b>	<b>11.81</b>	<b>300</b>	<b>300</b>	<b>12.80</b>	<b>12.80</b>	<b>325</b>	<b>325</b>	<b>3.12</b>	<b>43.0</b>
SK1-304-6 6" inlet cap	96861	9.84	9.84	250	250	10.83	10.83	275	275	-	6.2
SK1-308-6 6" outlet cap	96862	9.84	9.84	250	250	10.83	10.83	275	275	-	6.0
SK1-404-6 6" inlet cap	96863	11.81	11.81	300	300	12.80	12.80	325	325	-	7.2
SK1-408-6 6" outlet cap	96864	11.81	11.81	300	300	12.80	12.80	325	325	-	7.0
Universal end/4" inlet outlet cap	96824	11.81	11.81	300	300	12.6	12.6	320	320	-	0.4
Debris strainer for 4" bottom knockout	93488	-	-	-	-	-	-	-	-	-	0.2
4" oval to 6" round outlet adaptor	95140	-	-	-	-	-	-	-	-	-	1.1
Installation device	97477	-	-	-	-	-	-	-	-	-	2.8
Grate removal tool	01318	-	-	-	-	-	-	-	-	-	0.3

**Notes:**  
 1. PowerDrain is sold as channel only. Choose appropriate grate from page 74.  
 2. Preformed 4" dia. & 6" oval drill-outs cast on underside of certain channels (00, 5, 10, 010, 0103, 15, 20, 020, 0203, 25, 30, 030, 0303, 35, 40, 040, 0403).  
 3. Closing/outlet cap can be cut down to suit all channels.  
 4. Catch basin details on page 73.  
 5. Debris strainer details for 4" dia. outlet on page 103.

Polymer concrete catch basins

Polymer concrete catch basins are used either as stand alone area drains or more commonly as the outlet to a trench run. They provide the highest hydraulic output and allow easy access to pipe system for maintenance.

Type 901D provides an in-line catch basin (same width and visually indistinguishable from trench run) and the Series 600D is 12" wide and provides greater hydraulic output.

SK1-Type 901D  
4 in. wide in-line catch basin



SK1-Series 600D  
12 in. wide catch basin

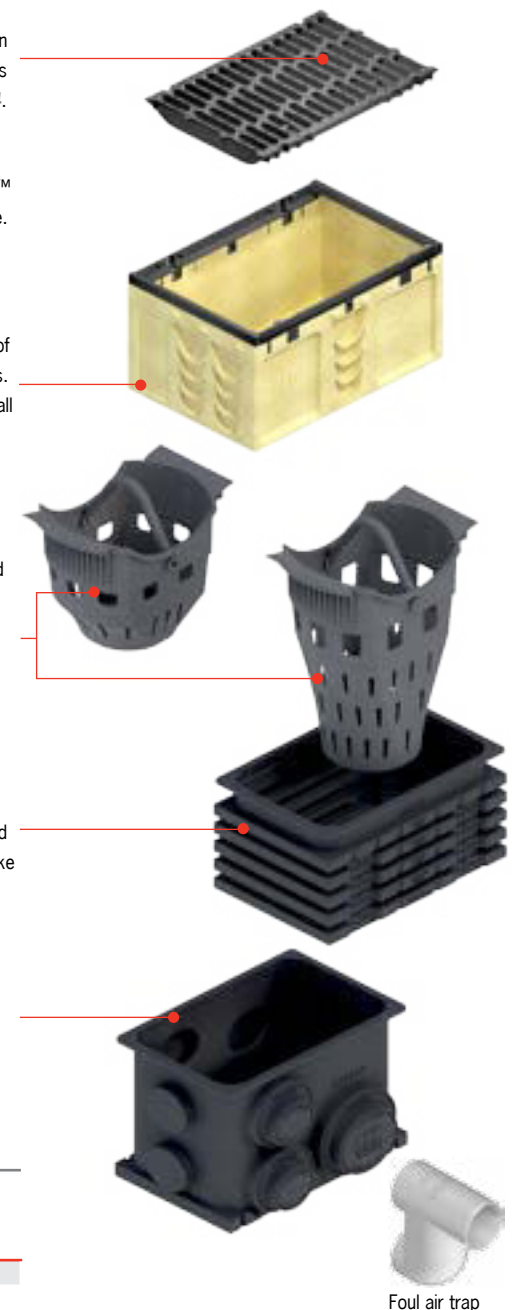

**Series 600 grates** - choice of Class F slotted or Class E longitudinal ADA compliant ductile iron grates with PowerLok™ boltless locking or Class F slotted ductile iron 4-bolt grate. See page 94.

**Type 900 grates** - choice of Class F slotted or ADA compliant ductile iron grates with PowerLok™ boltless locking or slotted ductile iron 4-bolt grate. See page 74.

**Top section** - polymer concrete with integrally cast-in ductile iron frame. Guides aid connection of male channel ends at #10, 20, 30 and 40 depths. Other channels can be connected by removing wall to required height. Blanking end rail supplied with SK1-901D. See page 155.

**Trash bucket** - plastic trash bucket designed to collect debris washed from trench run. Supported in catch basin top to avoid creation of a vacuum and reduction in outflow. SK1-631D uses deeper bucket with riser.

**Riser** - a plastic riser, supplied with SK1-631D, designed to provide additional catch basin depth and hydraulic output. Guides enable cutting to size at 2" (50mm) intervals - minimum 2" and maximum 12" height. Additional units can be used (a maximum of 2 is recommended to ensure snake access is maintained and for structural stability). Contact ACO for non-polyethylene riser.

**Base** - polyethylene bases with wide range of Schedule 40 4", 6" and 8" cut-outs for easy pipe connection. Cut-outs on end and side allow connection of ACO foul air trap. Contact ACO for non-polyethylene bases.

Parts table - S100K Catch basins

	Part No.	Volume Gallons*	Weight lbs
SK1-901D in-line catch basin - 19.69" (0.5m)	67051	12.5	86.0
SK1-621D catch basin - 19.69" (0.5m)	67053	24.9	75.7
SK1-631D catch basin - 19.69" (0.5m)	67054	34.7	85.7
Series 600 optional riser	99902	9.8	10.0
Foul air trap - fits both Type 901D & 600 basins	90854	-	1.2

\* Volume is up to grate seat and without trash bucket.

Foul air trap

# ACO DRAIN

## Available S100K grates

Description	Part No.	Length inches (m)	Slot Size inches	Intake area sq. in.	Wgt lbs	PL	✓	✗	✓	28.1
<b>F</b> Load Class F - 200,000lbs - EN1433 <b>4,177psi</b> <b>Heavy Duty</b>										
<b>Longitudinal iron</b>										
Iron	96096	19.69" (0.5m)	1.36 x 0.45	25.2	13.6	PL	✓	✗	✓	28.1
Ductile iron to ASTM A 536-84 - minimum grade 65-45-12										
<b>Slotted iron</b>										
Iron	96082	19.69" (0.5m)	0.43 x 1.98 avg.	25.7	12.3	PL	✗	✗	✓	35.6
Ductile iron to ASTM A 536-84 - minimum grade 65-45-12										
<b>4-bolt* iron</b>										
Iron	99590	19.69" (0.5m)	0.71 x 1.81 avg.	36.0	10.8	Bolt	✗	✗	✓	35.6
Ductile iron to ASTM A 536-84 - minimum grade 65-45-12. * Supplied with 4 qty M10 bolts.										

**Key**

- Locking mechanism
- Compliant with Americans with Disabilities Act of 1990 Section 4.5.4 (Page 140)
- ASME A112.6.3 - 2001 Heel resistant less than 0.31" (8mm) (Page 140)
- Bicycle Safe compliant to Australian Standard AS 3996 - 2006 (Page 140)
- Anti-slip grates - BPN over 24 (Page 140)

## Choosing S200K grates

There are three available grate styles to fit the S100K heavy duty channel body.

The conventional slotted grate, with PowerLok™, gives an excellent all-around heavy duty solution with the ease of the PowerLok™ locking/unlocking mechanism. Ideal for use where regular removal of the grate for maintenance is required.

The ADA compliant, longitudinal slotted grate, with PowerLok™, gives the ideal solution to a heavy duty location where some pedestrian access may be required.

Although easy locking and grate removal is important for maintenance, some specific applications require a 4-bolt solution. The four threaded stainless steel inserts in the S100K channel body allow a 4-bolt grate to be bolted into the channel (using 4qty M10 bolts) for ultimate stiffness and security. Tamper resistant bolts can also be used.



# PowerDrain S100K

## PowerLok™ - boltless locking system



**1**

**Fit grate**

To lock, position side of grate into lugs on rail, place hook part of tool into 'V' and push towards rail.



**2**

**Grate removal**

To open PowerLok™, insert tool between rail and PowerLok™ device.



**3**

**Grate removal**

Rotate tool 90°, PowerLok™ device should push away from rail.

## PowerLok™ - safety clip

For areas of extra security or safety concerns, an optional safety clip is available that provides a visual alert if the PowerLok™ devices are left open. The clip push fits next to the PowerLok™ device and sits level with the grate when the grate is locked. The clip cannot be fitted if the PowerLok™ is open. If all grates are engaged, a run of red dots is visible.



## 4-Bolt grates



**1**

**Fit grate**

Position grate onto channel, align holes in grate with matching holes in edge rail.



**2**

**Fit grate**

Using wrench or socket set to tighten. If using a torque wrench, do not set to more than 15 ft. lbs.



**3**

**Grate removal**

To remove grates, use wrench or socket set. Carefully store bolts for refitting of grates.

## Grate accessories

	Part No.	Weight lbs
PowerLok safety clip (red)	10443	0.1
Replacement bolt for 4-bolt grate	95526	0.1
Tamper resistant bolt for 4-bolt grate	138127	0.1
Tamper resistant bolt drive	138128	0.1



Requires tamper resistant drive bit





**S200K** - 8" wide heavy duty system

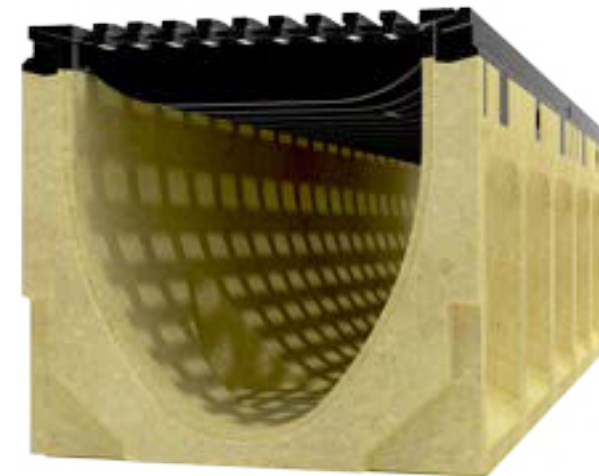

S200K is an 8" wide system with choice of Class F (90 ton) slotted or Class E (60 ton) ADA compliant ductile iron grates featuring the PowerLok™ patented boltless locking system. A 4-bolt slotted grate is also available.



**PowerDrain S200K**



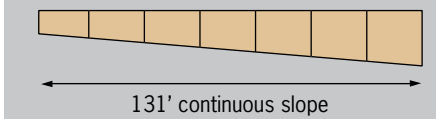
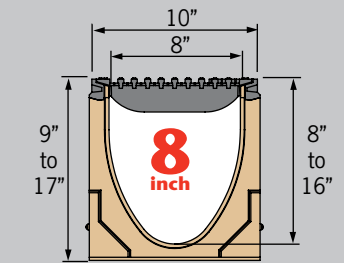





**Key Dimensions**



**Typical applications**

- Airports
- Highways
- Heavy duty industrial areas
- Gas stations
- Docks & ports
- Military bases
- Truck stops

**Selection criteria**

- A B C D E F** Light to heavy industrial duty loads 
-  Product can be used towards LEED & EPA requirements
-  Resistant to many everyday chemicals. *Check page 139*
-   Multiple grate options to meet legal requirements
-   Multiple grate options to meet design requirements
-  Increased hydraulic capacity
-  Constant depth and/or sloped depth channels

System layout

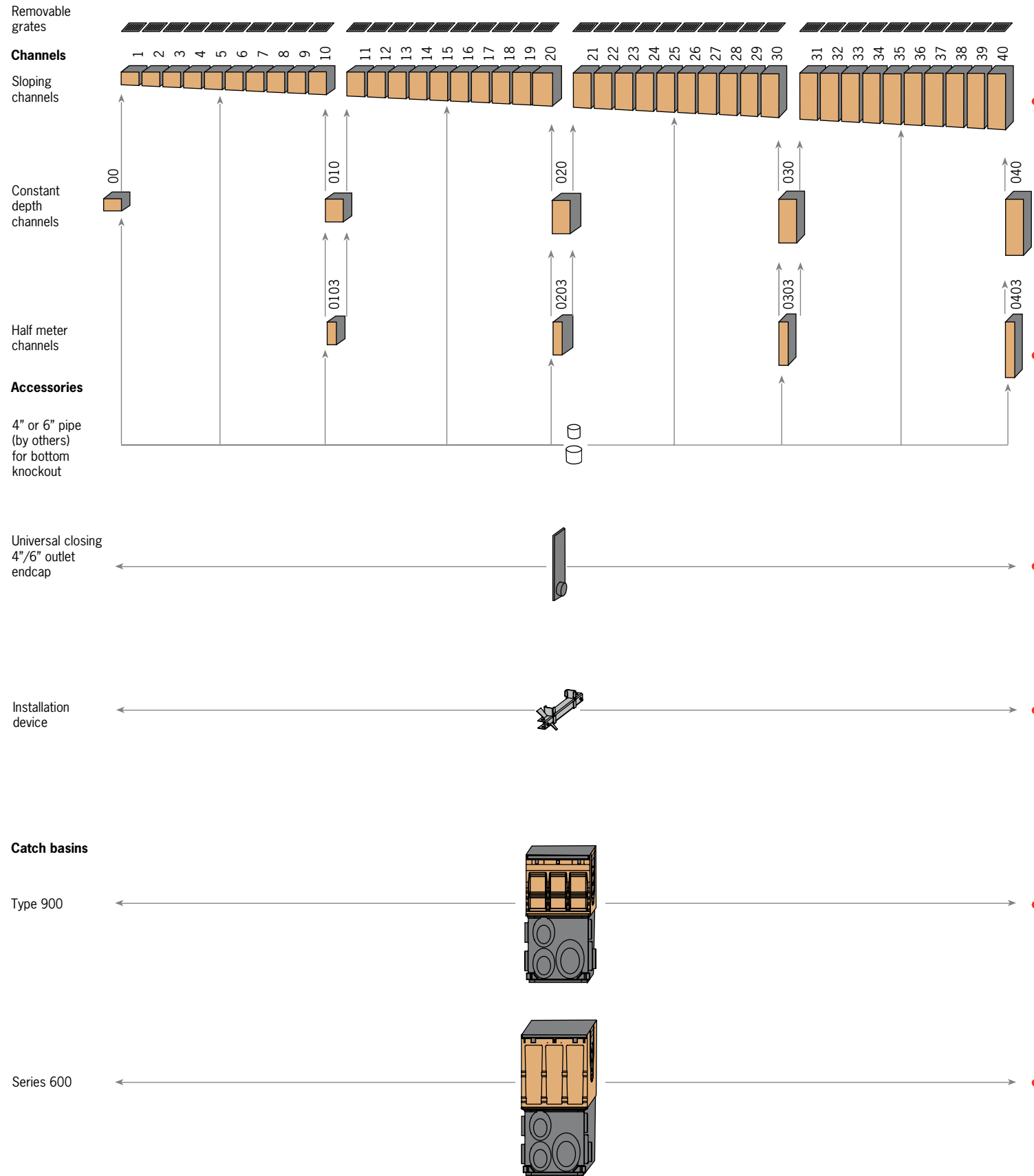

**Meter channels - sloping & constant depth**

0.5% sloped channels with ductile iron edge rail, in meter lengths and 40 depths which connect to create 40 meter (131'-2") continuously sloping run.

Constant depth channels are available in 5 depths. Can be used to create non-sloped runs, or inserted in sloped runs to increase length.

Bottom knockouts on all constant depths and 5, 10, 15, 20, 25, 30, 35, 40 channels.



**Half meter channels**

Constant depth channels with ductile iron edge rail, in 4 depths supplement meter channels. Side knockout and profiling enable side junction to be created. Bottom knockouts on all half meter channels.

**Closing/4 in. or 6 in. outlet cap**

Fits all channels and manufactured from black polypropylene to complement edge rail. Guides aid cutting to correct height. Wings clip cap onto end of channel. 4" and 6" bell end provides connection to Schedule 40 pipe. Seal using appropriate flexible sealant.

**Note:** For depth 1-10 channels, ACO recommends removal of unused sections of bell end to ensure adequate pavement material coverage.



**Installation device**

Fits molded recesses on body of channel. Provides height and joint alignment - a sliding clamp locks the two channels together. Bolt to rebar on either side of channel to hold channels in place during concrete pour. Not reusable; it is 'lost' within concrete haunch.



**Type 902D In-line catch basin**

Two part in-line catch basin with ductile iron edge rail; bases have 4", 6" and 8" drill-outs for pipe connections. Supplied with plastic trash bucket.

Any channel can be connected to catch basin by removing the end wall to the correct height with a box cutter. Cut-out guides provided for connection to channels 00, 010, 020, 030 and 040. All cut-outs to receive male channel ends. One blanking end plate supplied with in-line catch basin.



**Series 600D catch basin**

A two part in-line catch basin with ductile iron edge rail; bases have 4", 6" and 8" drill-outs for pipe connections. Supplied with plastic trash bucket. Optional riser available for increased depth. Contact ACO for non-polyethylene riser/bases.

Any channel can be connected to catch basin by removing the end/side wall to the correct height. Drill-out guides provided for connection to channels 00, 010, 020, 030 and 040. All cut-outs to receive male channel ends. Two blanking end plates supplied with inline catch basin.



Product dimensions

Meter channels

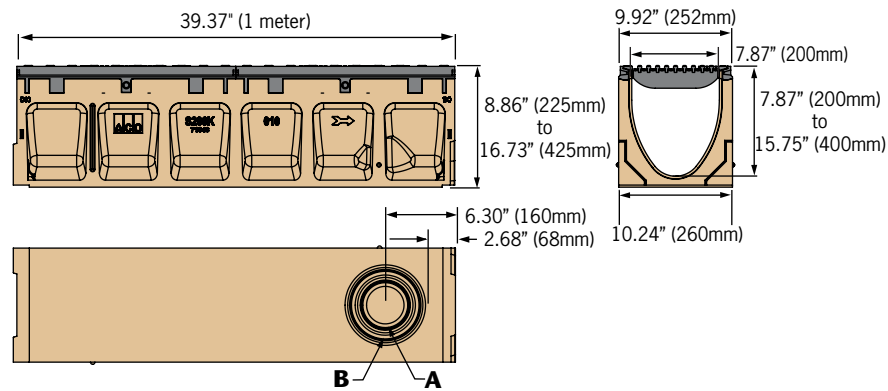

Half meter channels

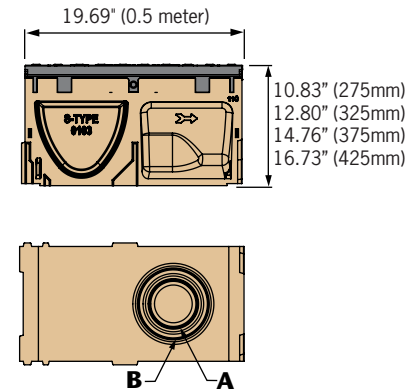

Closing/4 in. or 6 in. outlet cap

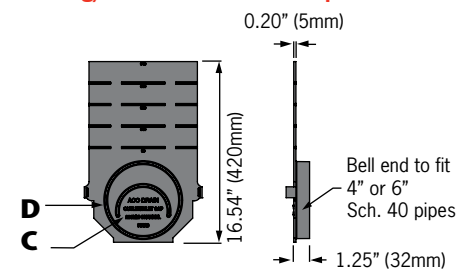

Installation device

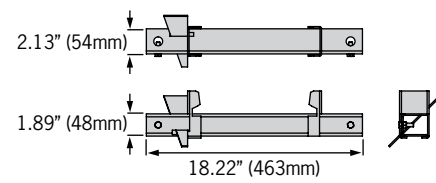

SK2-902D In-line catch basin

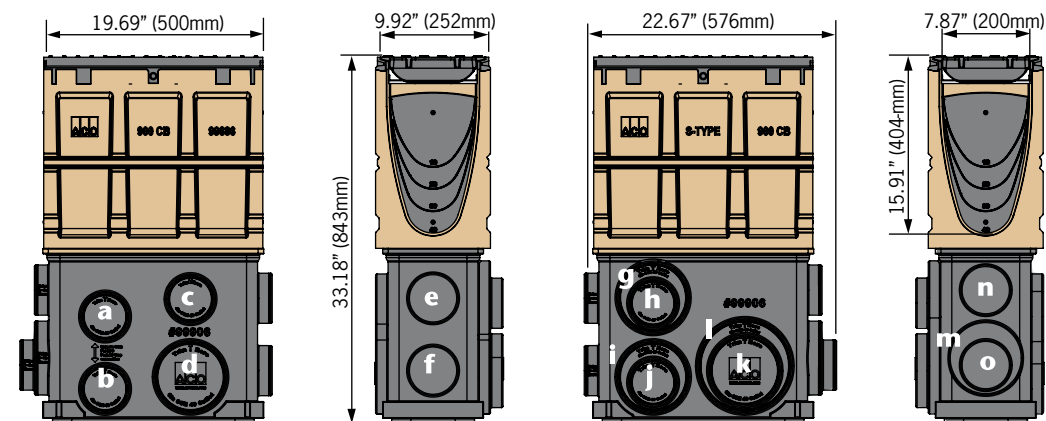

Outlet flow rates

Channels		Invert in.	GPM	CFS
A	SK2-00 - 4" round	7.87"	153	0.34
A	SK2-40 - 4" round	15.75"	216	0.48
B	SK2-00 - 6" round	7.87"	344	0.77
B	SK2-40 - 6" round	15.75"	486	1.08
C	SK2-00 - 4" round	7.87"	132	0.29
C	SK2-40 - 4" round	15.75"	202	0.45
D	SK2-10 - 6" round	9.84"	320	0.71
D	SK2-40 - 6" round	15.75"	437	0.97

Catch basins		SK2-902D			SK2-621D			SK2-631D		
Outlet	Size (Sch 40)	Invert in.	GPM	CFS	Invert in.	GPM	CFS	Invert in.	GPM	CFS
a	4" round	25.33"	263	0.59	29.80"	287	0.64	41.80"	343	0.77
b	4" round	31.83"	297	0.66	36.29"	319	0.71	48.29"	370	0.83
c	4" round	23.76"	254	0.57	28.22"	279	0.62	40.22"	337	0.75
d	6" round	31.83"	658	1.47	36.29"	707	1.57	48.29"	824	1.84
e	4" round	23.91"	255	0.57	28.37"	280	0.62	40.37"	337	0.75
f	4" round	30.40"	290	0.65	34.87"	312	0.70	46.87"	365	0.81
g	6" round	24.68"	570	1.27	29.15"	626	1.40	41.15"	757	1.69
h	4" round	24.13"	256	0.57	28.59"	281	0.63	40.59"	338	0.75
i	6" round	31.82"	658	1.47	36.28"	707	1.57	48.28"	824	1.84
j	4" round	31.26"	294	0.66	35.72"	316	0.70	47.72"	368	0.82
k	6" round	31.26"	651	1.45	35.72"	701	1.56	47.72"	819	1.83
l	8" round	31.82"	1149	2.56	36.28"	1237	2.76	48.28"	1449	3.23
m	6" round	30.32"	640	1.43	34.78"	690	1.54	46.78"	810	1.81
n	4" round	23.19"	251	0.56	27.65"	276	0.61	39.65"	334	0.74
o	4" round	29.90"	288	0.64	34.36"	310	0.69	46.36"	363	0.81

Note: These are pipe flow rates at specified outlet, NOT channel flow rates. Catch basin flow rates without trash bucket - using trash bucket reduces flow.

SK2-621D catch basin

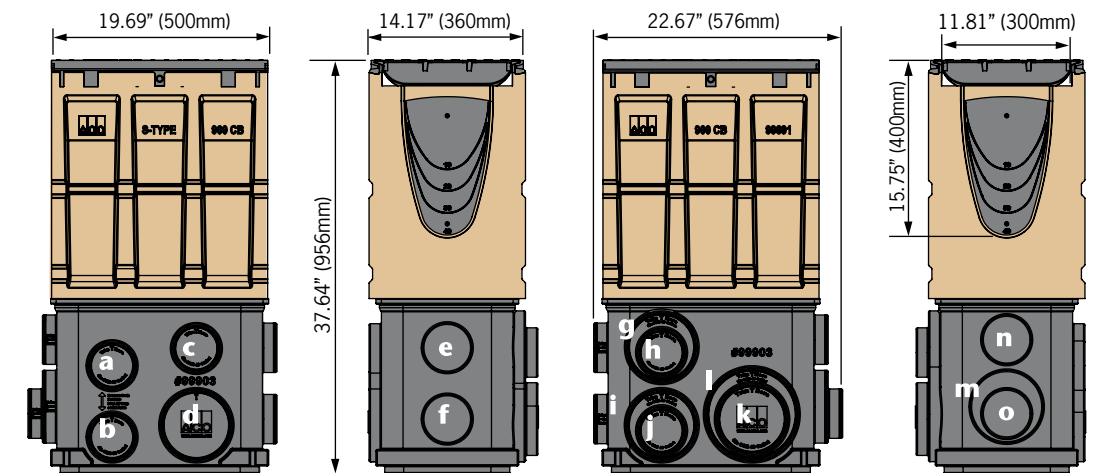

SK2-631D catch basin

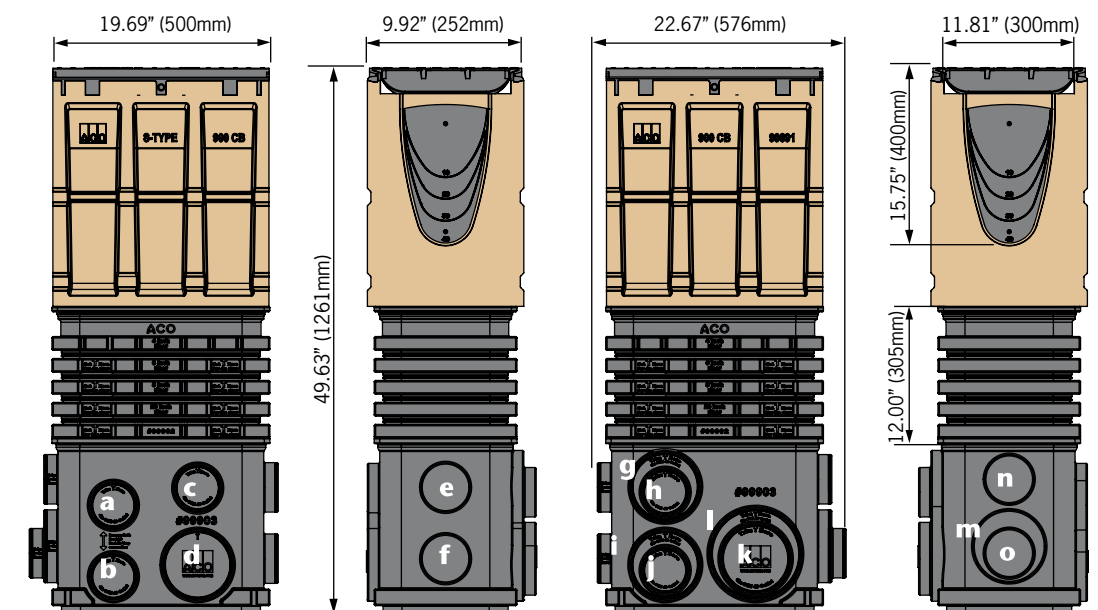

S200K Parts table

	Part No.	Invert Depth				Overall Depth				Vol Gal	Wgt lbs
		Inches		mm		Inches		mm			
		female	male	female	male	female	male	female	male		
<b>SK2-00 Constant depth channel - 39.37" (1m)<sup>2</sup></b>	<b>68041</b>	<b>7.87</b>	<b>7.87</b>	<b>200</b>	<b>200</b>	<b>8.86</b>	<b>8.86</b>	<b>225</b>	<b>225</b>	<b>7.54</b>	<b>85.2</b>
SK2-1 Sloped channel - 39.37" (1m)	68001	7.87	8.07	200	205	8.86	9.06	225	230	7.94	85.2
SK2-2 Sloped channel - 39.37" (1m)	68002	8.07	8.27	205	210	9.06	9.25	230	235	8.13	86.3
SK2-3 Sloped channel - 39.37" (1m)	68003	8.27	8.46	210	215	9.25	9.45	235	240	8.33	87.4
SK2-4 Sloped channel - 39.37" (1m)	68004	8.46	8.66	215	220	9.45	9.65	240	245	8.53	88.5
SK2-5 Sloped channel - 39.37" (1m) <sup>2</sup>	68005	8.66	8.86	220	225	9.65	9.84	245	250	8.74	89.6
SK2-6 Sloped channel - 39.37" (1m)	68006	8.86	9.06	225	230	9.84	10.04	250	255	8.95	90.7
SK2-7 Sloped channel - 39.37" (1m)	68007	9.06	9.25	230	235	10.04	10.24	255	260	9.16	91.8
SK2-8 Sloped channel - 39.37" (1m)	68008	9.25	9.45	235	240	10.24	10.43	260	265	9.37	92.9
SK2-9 Sloped channel - 39.37" (1m)	68009	9.45	9.65	240	245	10.43	10.63	265	270	9.58	94.0
SK2-10 Sloped channel - 39.37" (1m) <sup>2</sup>	68010	9.65	9.84	245	250	10.63	10.83	270	275	9.79	95.1
<b>SK2-010 Constant depth channel - 39.37" (1m)<sup>2</sup></b>	<b>68043</b>	<b>9.84</b>	<b>9.84</b>	<b>250</b>	<b>250</b>	<b>10.83</b>	<b>10.83</b>	<b>275</b>	<b>275</b>	<b>9.59</b>	<b>95.2</b>
<b>SK2-0103 Constant depth channel - 19.69" (0.5m)<sup>2</sup></b>	<b>68044</b>	<b>9.84</b>	<b>9.84</b>	<b>250</b>	<b>250</b>	<b>10.83</b>	<b>10.83</b>	<b>275</b>	<b>275</b>	<b>4.80</b>	<b>61.2</b>
SK2-11 Sloped channel - 39.37" (1m)	68011	9.84	10.04	250	255	10.83	11.02	275	280	10.01	96.2
SK2-12 Sloped channel - 39.37" (1m)	68012	10.04	10.24	255	260	11.02	11.22	280	285	10.22	97.3
SK2-13 Sloped channel - 39.37" (1m)	68013	10.24	10.43	260	265	11.22	11.42	285	290	10.44	98.4
SK2-14 Sloped channel - 39.37" (1m)	68014	10.43	10.63	265	270	11.42	11.61	290	295	10.66	99.6
SK2-15 Sloped channel - 39.37" (1m) <sup>2</sup>	68015	10.63	10.83	270	275	11.61	11.81	295	300	10.88	100.7
SK2-16 Sloped channel - 39.37" (1m)	68016	10.83	11.02	275	280	11.81	12.01	300	305	11.10	101.8
SK2-17 Sloped channel - 39.37" (1m)	68017	11.02	11.22	280	285	12.01	12.20	305	310	11.32	102.9
SK2-18 Sloped channel - 39.37" (1m)	68018	11.22	11.42	285	290	12.20	12.40	310	315	11.54	104.0
SK2-19 Sloped channel - 39.37" (1m)	68019	11.42	11.61	290	295	12.40	12.60	315	320	11.76	105.1
SK2-20 Sloped channel - 39.37" (1m) <sup>2</sup>	68020	11.61	11.81	295	300	12.60	12.80	320	325	11.98	106.2
<b>SK2-020 Constant depth channel - 39.37" (1m)<sup>2</sup></b>	<b>68045</b>	<b>11.81</b>	<b>11.81</b>	<b>300</b>	<b>300</b>	<b>12.80</b>	<b>12.80</b>	<b>325</b>	<b>325</b>	<b>11.78</b>	<b>106.2</b>
<b>SK2-0203 Constant depth channel - 19.69" (0.5m)<sup>2</sup></b>	<b>68046</b>	<b>11.81</b>	<b>11.81</b>	<b>300</b>	<b>300</b>	<b>12.80</b>	<b>12.80</b>	<b>325</b>	<b>325</b>	<b>5.89</b>	<b>68.8</b>
SK2-21 Sloped channel - 39.37" (1m)	68021	11.81	12.01	300	305	12.80	12.99	325	330	12.21	107.3
SK2-22 Sloped channel - 39.37" (1m)	68022	12.01	12.20	305	310	12.99	13.19	330	335	12.42	108.4
SK2-23 Sloped channel - 39.37" (1m)	68023	12.20	12.40	310	315	13.19	13.39	335	340	12.65	109.5
SK2-24 Sloped channel - 39.37" (1m)	68024	12.40	12.60	315	320	13.39	13.58	340	345	12.87	110.6
SK2-25 Sloped channel - 39.37" (1m) <sup>2</sup>	68025	12.60	12.80	320	325	13.58	13.78	345	350	13.10	111.7
SK2-26 Sloped channel - 39.37" (1m)	68026	12.80	12.99	325	330	13.78	13.98	350	355	13.32	112.3
SK2-27 Sloped channel - 39.37" (1m)	68027	12.99	13.19	330	335	13.98	14.17	355	360	13.56	113.9
SK2-28 Sloped channel - 39.37" (1m)	68028	13.19	13.39	335	340	14.17	14.37	360	365	13.77	115.8
SK2-29 Sloped channel - 39.37" (1m)	68029	13.39	13.58	340	345	14.37	14.57	365	370	13.99	116.1
SK2-30 Sloped channel - 39.37" (1m) <sup>2</sup>	68030	13.58	13.78	345	350	14.57	14.76	370	375	14.22	117.2
<b>SK2-030 Constant depth channel - 39.37" (1m)<sup>2</sup></b>	<b>68047</b>	<b>13.78</b>	<b>13.78</b>	<b>350</b>	<b>350</b>	<b>14.76</b>	<b>14.76</b>	<b>375</b>	<b>375</b>	<b>14.01</b>	<b>117.2</b>
<b>SK2-0303 Constant depth channel - 19.69" (0.5m)<sup>2</sup></b>	<b>68048</b>	<b>13.78</b>	<b>13.78</b>	<b>350</b>	<b>350</b>	<b>14.76</b>	<b>14.76</b>	<b>375</b>	<b>375</b>	<b>7.05</b>	<b>73.3</b>
SK2-31 Sloped channel - 39.37" (1m)	68031	13.78	13.98	350	355	14.76	14.96	375	380	14.44	118.4
SK2-32 Sloped channel - 39.37" (1m)	68032	13.98	14.17	355	360	14.96	15.16	380	385	14.67	119.5
SK2-33 Sloped channel - 39.37" (1m)	68033	14.17	14.37	360	365	15.16	15.35	385	390	14.89	120.6
SK2-34 Sloped channel - 39.37" (1m)	68034	14.37	14.57	365	370	15.35	15.55	390	395	15.11	121.7
SK2-35 Sloped channel - 39.37" (1m) <sup>2</sup>	68035	14.57	14.76	370	375	15.55	15.75	395	400	15.34	122.8
SK2-36 Sloped channel - 39.37" (1m)	68036	14.76	14.96	375	380	15.75	15.94	400	405	15.56	123.9
SK2-37 Sloped channel - 39.37" (1m)	68037	14.96	15.16	380	385	15.94	16.14	405	410	15.78	125.0
SK2-38 Sloped channel - 39.37" (1m)	68038	15.16	15.35	385	390	16.14	16.34	410	415	16.02	126.1
SK2-39 Sloped channel - 39.37" (1m)	68039	15.35	15.55	390	395	16.34	16.54	415	420	16.23	127.2
SK2-40 Sloped channel - 39.37" (1m) <sup>2</sup>	68040	15.55	15.75	395	400	16.54	16.73	420	425	16.46	128.3
<b>SK2-040 Constant depth channel - 39.37" (1m)<sup>2</sup></b>	<b>68049</b>	<b>15.75</b>	<b>15.75</b>	<b>400</b>	<b>400</b>	<b>16.73</b>	<b>16.73</b>	<b>425</b>	<b>425</b>	<b>16.27</b>	<b>128.3</b>
<b>SK2-0403 Constant depth channel - 19.69" (0.5m)<sup>2</sup></b>	<b>68050</b>	<b>15.75</b>	<b>15.75</b>	<b>400</b>	<b>400</b>	<b>16.73</b>	<b>16.73</b>	<b>425</b>	<b>425</b>	<b>8.14</b>	<b>82.1</b>
Universal end cap	96823	15.75	15.75	400	400	16.54	16.54	420	420	-	1.4
Debris strainer for 4" bottom knockout	93488	-	-	-	-	-	-	-	-	-	0.2
Installation device	97478	-	-	-	-	-	-	-	-	-	4.0
Grate removal tool	01318	-	-	-	-	-	-	-	-	-	0.3

- Notes:**
- PowerDrain is sold as channel only. Choose appropriate grate from page 84.
  - Preformed 4" & 6" dia knock-outs cast on underside of certain channels (00, 5, 10, 010, 0103, 15, 20, 020, 0203, 25, 30, 030, 0303, 35, 40, 040, 0403).
  - Closing/outlet cap can be cut down to suit all channels.
  - Catch basin details on page 83.
  - Debris strainer details for 4" dia. outlet on page 103.

Polymer concrete catch basins

Polymer concrete catch basins are used either as stand alone area drains or more commonly as the outlet to a trench run. They provide the highest hydraulic output and allow easy access to pipe system for maintenance.

Type 902D provides an in-line catch basin (same width and visually indistinguishable from trench run) and the Series 600D is 12" wide and provides greater hydraulic output.

SK2-Type 902D  
8 in. wide in-line catch basin



**Series 600 grates** - choice of Class F slotted or Class E longitudinal ADA compliant ductile iron grates with PowerLok™ boltless locking or Class F slotted ductile iron 4-bolt grate. See page 94.

**Type 900 grates** - choice of Class F slotted or Class E longitudinal ADA compliant ductile iron grates supplied with PowerLok™ boltless locking or Class F slotted ductile iron 4-bolt grate. See page 84.

**Top section** - polymer concrete with integrally cast-in ductile iron frame for grate. Guides aid connection of male channel ends at #10,20,30 and 40 depths. Other channels can be connected by removing wall to required height. Blanking end rail supplied with SK2-902D and kit available for Series 600D. See page 155.

**Trash bucket** - plastic trash bucket designed to collect debris washed from trench run. Supported in catch basin top to avoid creation of a vacuum and flow reduction. SK2-631D uses deep bucket with riser.

**Riser** - a plastic riser, supplied with SK2-631D, designed to provide additional catch basin depth and hydraulic output. Guides enable cutting to size at 2" (50mm) intervals - minimum 2" and maximum 12" height. Additional units can be used (a maximum of 2 is recommended to ensure snake access is maintained and for structural stability). Contact ACO for non-polyethylene riser.

**Base** - polyethylene bases with wide range of Schedule 40 4", 6" and 8" cut-outs for easy pipe connection. Cut-outs on end and side allow connection of ACO foul air trap. Contact ACO for non-polyethylene bases.

SK2-Series 600D  
12 in. wide catch basin



Parts table - S200K Catch basins

	Part No.	Volume Gallons*	Weight lbs
SK2-902D in-line catch basin - 19.69" (0.5m)	68053	18.1	81.8
SK2-621D catch basin - 19.69" (0.5m)	68055	30.4	116.0
SK2-631D catch basin - 19.69" (0.5m)	68056	40.2	126.0
Series 600 optional riser	99902	9.8	10.0
Foul air trap - fits both Type 902D & 600 basins	90854	-	1.2

\* Volume is up to grate seat and without trash bucket.

# ACO DRAIN

# PowerDrain S200K

## Available S200K grates

Description	Part No.	Length inches (m)	Slot Size inches	Intake area sq. in.	Wgt lbs	PL	✓	✗	✓	55.6
<b>E</b> <b>Load Class E - 135,000lbs - EN1433</b> <b>2,321psi</b> <b>Industrial</b>										
<b>Longitudinal iron</b>										
Iron	72263	19.69" (0.5m)	1.34 x 0.43	52.4	26.4	PL	✓	✗	✓	55.6
Ductile iron to ASTM A 536-84 - minimum grade 65-45-12 This grate complies with RR-F-621E '200,000lb proof load' test.										
<b>F</b> <b>Load Class F - 200,000lbs - EN1433</b> <b>3,481psi</b> <b>Heavy duty</b>										
<b>Slotted iron</b>										
Iron	02449	19.69" (0.5m)	0.71 x 3.62 avg.	70.1	30.8	PL	✗	✗	✓	21.4
Ductile iron to ASTM A 536-84 - minimum grade 65-45-12 This grate complies with RR-F-621E '200,000lb proof load' test.										
<b>4-bolt iron</b>										
Iron	99591	19.69" (0.5m)	0.71 x 3.62 avg.	71.3	26.4	Bolt	✗	✗	✓	21.4
Ductile iron to ASTM A 536-84 - minimum grade 65-45-12 This grate complies with RR-F-621E '200,000lb proof load' test. * Supplied with 4qty M10 bolts.										

- Key**
- Locking mechanism
  - 200,000lb proof load compliant (Page 128)
  - Compliant with Americans with Disabilities Act of 1990 Section 4.5.4 (Page 140)
  - Bicycle Safe compliant to Australian Standard AS 3996 - 2006 (Page 140)
  - ASME A112.6.3 - 2001 Heel resistant less than 0.31" (8mm) (Page 140)
  - Anti-slip grates - BPN over 24 (Page 140)

## Choosing S200K grates

There are three available grate styles to fit the S200K heavy duty channel body.

The conventional slotted grate, with PowerLok™, gives an excellent all-around heavy duty solution with the ease of the PowerLok™ locking/unlocking mechanism. Ideal for use where regular removal of the grate for maintenance is required.

The ADA compliant, longitudinal slotted grate, with PowerLok™, gives the ideal solution to a heavy duty location where some pedestrian access may be required.

Although easy locking and grate removal is important for maintenance, some specific applications require a 4-bolt solution. The four threaded stainless steel inserts in the S200K channel body allow a 4-bolt grate to be bolted into the channel (using 4qty M10 bolts) for ultimate stiffness and security. Tamper resistant bolts can also be used.



## PowerLok™ - boltless locking system



**1**

**Fit grate**

To lock, position side of grate into lugs on rail, place hook part of tool into 'V' and push towards rail.



**2**

**Grate removal**

To open PowerLok™, insert tool between rail and PowerLok™ device.



**3**

**Grate removal**

Rotate tool 90°, PowerLok™ device should push away from rail.

## PowerLok™ - safety clip

For areas of extra security or safety concerns, an optional safety clip is available that provides a visual alert if the PowerLok™ devices are left open. The clip push fits next to the PowerLok™ device and sits level with the grate when the grate is locked. The clip cannot be fitted if the PowerLok™ is open. If all grates are engaged, a run of red dots is visible.



## 4-Bolt grates



**1**

**Fit grate**

Position grate onto channel, align holes in grate with matching holes in edge rail.



**2**

**Fit grate**

Using wrench or socket set to tighten. If using a torque wrench, do not set to more than 15 ft. lbs.



**3**

**Grate removal**

To remove grates, use wrench or socket set. Carefully store bolts for refitting of grates.

## Grate accessories

	Part No.	Weight lbs
PowerLok safety clip (red)	10443	0.1
Replacement bolt for 4-bolt grate	95526	0.1
Tamper resistant bolt for 4-bolt grate	138127	0.1
Tamper resistant bolt drive	138128	0.1



Requires tamper resistant drive bit



### S300K - 12" wide heavy duty system

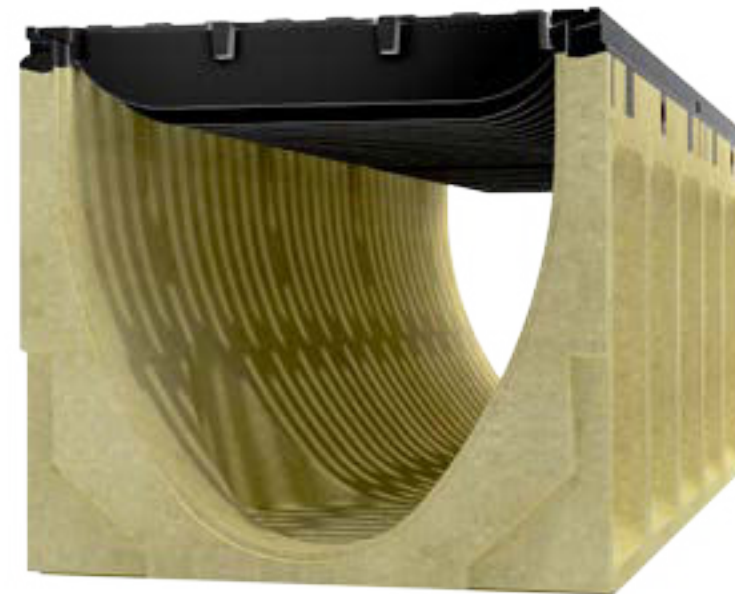

S300K is a 12" wide system with choice of Class F (90 ton) slotted or Class E (60 ton) ADA compliant ductile iron grates featuring the patented PowerLok™ boltless locking system. A 4-bolt slotted grate is also available.



## PowerDrain S300K



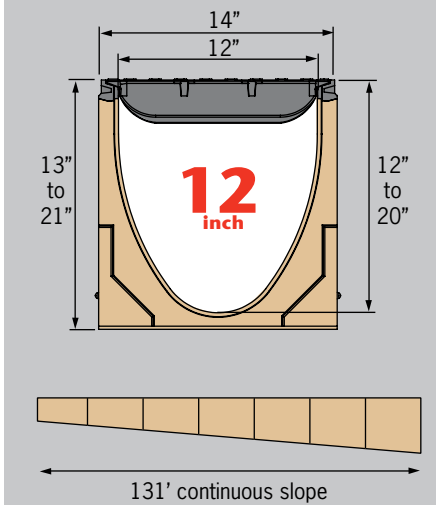



### Key Dimensions



### Typical applications

- Airports
- Highways
- Heavy duty industrial areas
- Gas stations
- Docks & ports
- Military bases
- Truck stops

### Selection criteria

- A B C D E F** Light to heavy industrial duty loads 
-  Product can be used towards LEED & EPA requirements
-  Resistant to many everyday chemicals. *Check page 139*
-  Multiple grate options to meet legal requirements
-  Multiple grate options to meet design requirements
-  Increased hydraulic capacity
-  Constant depth and/or sloped depth channels

System layout

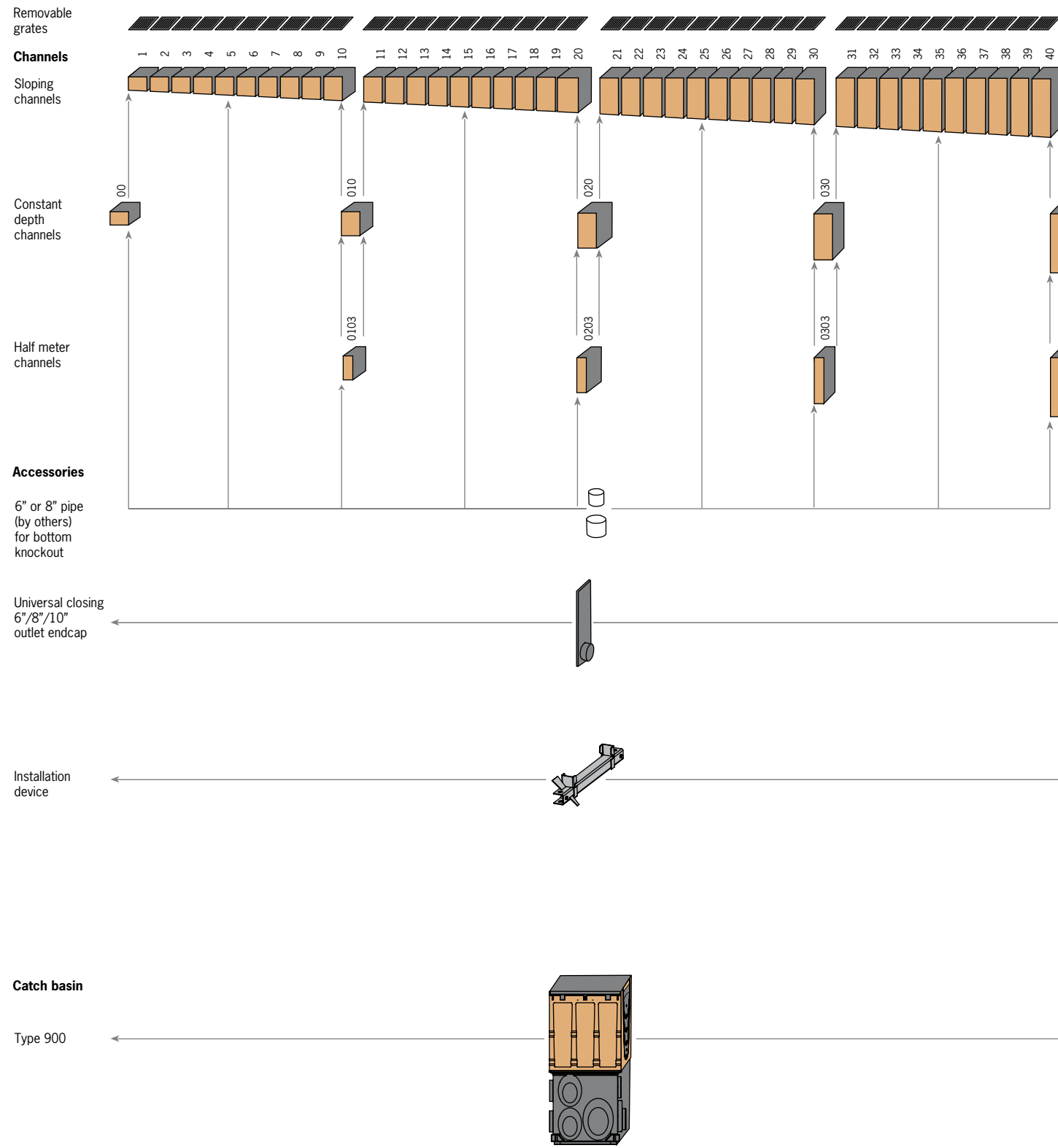

**Meter channels - sloping & constant depth**

0.5% sloped channels with ductile iron edge rail; in meter lengths and 40 depths which connect to create 40 meter (131'-2") continuously sloping run.

Constant depth channels are available in 5 depths. Can be used to create non-sloped runs, or inserted in sloped runs to increase length.

Bottom knockouts on all constant depths and 5, 10, 15, 20, 25, 30, 35, 40 channels.

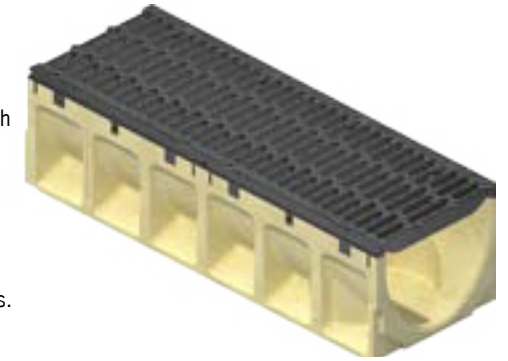

**Half meter channels**

Constant depth channels with ductile iron edge rail; in 4 depths supplement meter channels. Side knockout and profiling enable side junction to be created. Bottom knockouts on all half meter channels.



**Closing/6 in., 8 in. or 10 in. outlet cap**

Fits all channels and manufactured from black polypropylene to complement edge rail. Guides aid cutting to correct height. Wings clip cap onto end of channel. 6", 8" and 10" bell end provides connection to Schedule 40 pipe. Seal using appropriate flexible sealant.

**Note:** For depth 1-10 channels, ACO recommends removal of unused sections of bell end to ensure adequate pavement material coverage.



**Installation device**

Fits molded recesses on body of channel. Provides height and joint alignment - a sliding clamp locks the two channels together. Bolt to rebar on either side of channel to hold channels in place during concrete pour. Not reusable; it is 'lost' within concrete haunch.



**Type 903D/904D In-line catch basins**

A two part in-line catch basin with ductile iron edge rail; bases have 4", 6" and 8" drill-outs for pipe connections. Supplied with plastic trash bucket. Optional riser available for increased depth. Contact ACO for non-polyethylene riser/bases.

Any channel can be connected to catch basin by removing the end/side wall to the correct height. Drill out guides provided for connection to channels 00, 010, 020, 030 and 040. All cut-outs to receive male channel ends. Blanking end rail supplied to stop concrete ingress during final pour.



Product dimensions

Meter channels

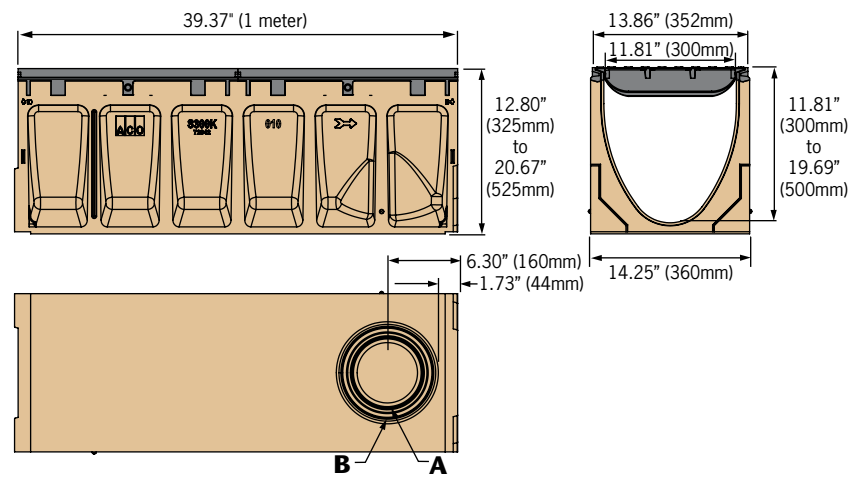

Half meter channels

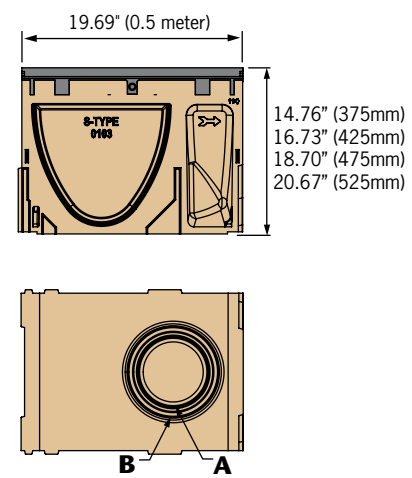

Outlet flow rates

Channels		Invert in.	GPM	CFS
A	SK3-00 - 6" round	11.81"	421	0.94
A	SK3-40 - 6" round	19.69"	544	1.21
B	SK3-00 - 8" round	11.81"	748	1.67
B	SK3-40 - 8" round	19.69"	966	2.15
C	SK3-00 - 6" round	11.81"	364	0.81
C	SK3-40 - 6" round	19.69"	500	1.11
D	SK3-10 - 8" round	13.78"	681	1.52
D	SK3-40 - 8" round	19.69"	863	1.92
E	SK3-20 - 10" round	15.75"	1116	2.49
E	SK3-40 - 10" round	19.69"	1304	2.91

Catch basins		SK3-903D			SK3-904D		
Outlet	Size (Sch 40)	Invert in.	GPM	CFS	Invert in.	GPM	CFS
a	4" round	29.80"	287	0.64	41.80"	343	0.77
b	4" round	36.29"	319	0.71	48.29"	370	0.83
c	4" round	28.22"	279	0.62	40.22"	337	0.75
d	6" round	36.29"	707	1.57	48.29"	824	1.84
e	4" round	28.37"	280	0.62	40.37"	337	0.75
f	4" round	34.87"	312	0.70	46.87"	365	0.81
g	6" round	29.15"	626	1.40	41.15"	757	1.69
h	4" round	28.59"	281	0.63	40.59"	338	0.75
i	6" round	36.28"	707	1.57	48.28"	824	1.84
j	4" round	35.72"	316	0.70	47.72"	368	0.82
k	6" round	35.72"	701	1.56	47.72"	819	1.83
l	8" round	36.28"	1237	2.76	48.28"	1449	3.23
m	6" round	34.78"	690	1.54	46.78"	810	1.81
n	4" round	27.65"	276	0.61	39.65"	334	0.74
o	4" round	34.36"	310	0.69	46.36"	363	0.81

Note: These are pipe flow rates at specified outlet, NOT channel flow rates. Catch basin flow rates without trash bucket - using trash bucket reduces flow.

Closing/6 in., 8 in. or 10 in. outlet cap

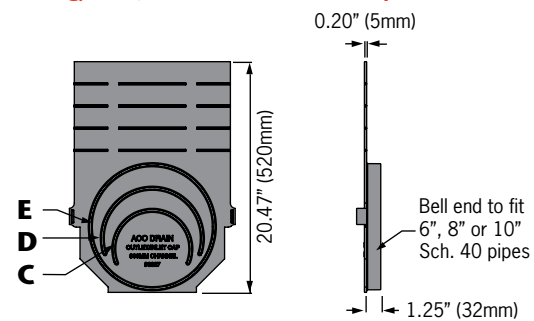

Installation device

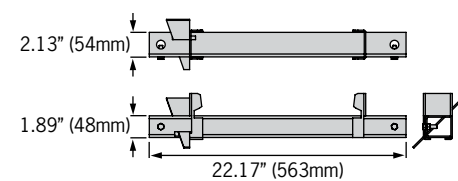

SK3-903D In-line catch basin

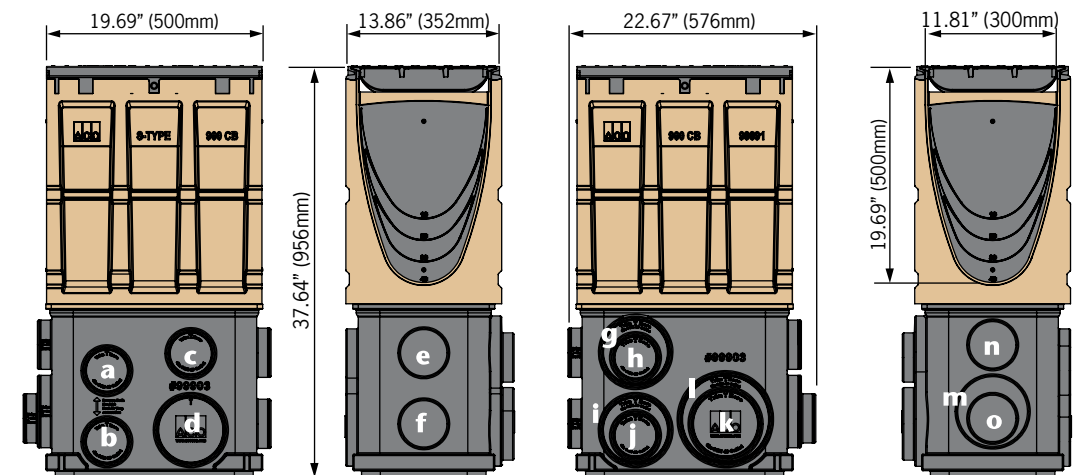

SK3-904D In-line catch basin

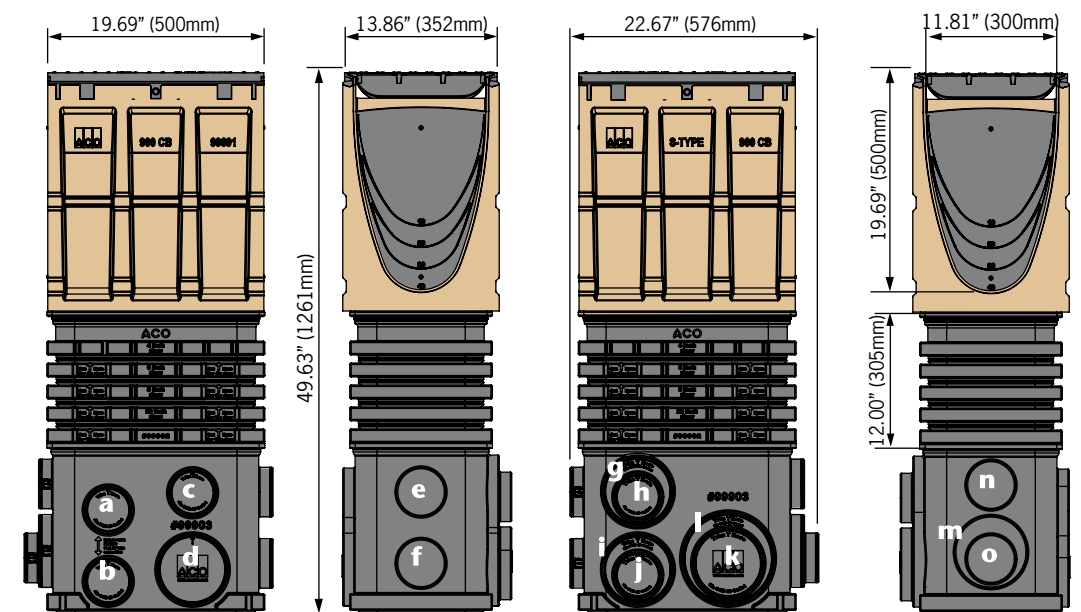



S300K Parts table

	Part No.	Invert Depth				Overall Depth				Vol Gal	Wgt lbs
		Inches		mm		Inches		mm			
		female	male	female	male	female	male	female	male		
<b>SK3-00 Constant depth channel - 39.37" (1m) <sup>2</sup></b>	<b>69041</b>	<b>11.81</b>	<b>11.81</b>	<b>300</b>	<b>300</b>	<b>12.80</b>	<b>12.80</b>	<b>325</b>	<b>325</b>	<b>18.01</b>	<b>140.0</b>
SK3-1 Sloped channel - 39.37" (1m)	69001	11.81	12.01	300	305	12.80	12.99	325	330	19.58	140.0
SK3-2 Sloped channel - 39.37" (1m)	69002	12.01	12.20	305	310	12.99	13.19	330	335	20.01	141.3
SK3-3 Sloped channel - 39.37" (1m)	69003	12.20	12.40	310	315	13.19	13.39	335	340	20.44	142.8
SK3-4 Sloped channel - 39.37" (1m)	69004	12.40	12.60	315	320	13.39	13.58	340	345	20.86	144.1
SK3-5 Sloped channel - 39.37" (1m) <sup>2</sup>	69005	12.60	12.80	320	325	13.58	13.78	345	350	21.28	145.4
SK3-6 Sloped channel - 39.37" (1m)	69006	12.80	12.99	325	330	13.78	13.98	350	355	21.69	146.9
SK3-7 Sloped channel - 39.37" (1m)	69007	12.99	13.19	330	335	13.98	14.17	355	360	22.11	148.2
SK3-8 Sloped channel - 39.37" (1m)	69008	13.19	13.39	335	340	14.17	14.37	360	365	22.51	149.5
SK3-9 Sloped channel - 39.37" (1m)	69009	13.39	13.58	340	345	14.37	14.57	365	370	22.92	150.9
SK3-10 Sloped channel - 39.37" (1m) <sup>2</sup>	69010	13.58	13.78	345	350	14.57	14.76	370	375	23.32	152.3
<b>SK3-010 Constant depth channel - 39.37" (1m) <sup>2</sup></b>	<b>69042</b>	<b>13.78</b>	<b>13.78</b>	<b>350</b>	<b>350</b>	<b>14.76</b>	<b>14.76</b>	<b>375</b>	<b>375</b>	<b>21.22</b>	<b>152.3</b>
<b>SK3-0103 Constant depth channel - 19.69" (0.5m) <sup>2</sup></b>	<b>69045</b>	<b>13.78</b>	<b>13.78</b>	<b>350</b>	<b>350</b>	<b>14.76</b>	<b>14.76</b>	<b>375</b>	<b>375</b>	<b>10.61</b>	<b>84.2</b>
SK3-11 Sloped channel - 39.37" (1m)	69011	13.78	13.98	350	355	14.76	14.96	375	380	23.72	153.6
SK3-12 Sloped channel - 39.37" (1m)	69012	13.98	14.17	355	360	14.96	15.16	380	385	24.11	155.0
SK3-13 Sloped channel - 39.37" (1m)	69013	14.17	14.37	360	365	15.16	15.35	385	390	24.51	156.4
SK3-14 Sloped channel - 39.37" (1m)	69014	14.37	14.57	365	370	15.35	15.55	390	395	24.89	157.7
SK3-15 Sloped channel - 39.37" (1m) <sup>2</sup>	69015	14.57	14.76	370	375	15.55	15.75	395	400	25.27	149.1
SK3-16 Sloped channel - 39.37" (1m)	69016	14.76	14.96	375	380	15.75	15.94	400	405	25.68	160.5
SK3-17 Sloped channel - 39.37" (1m)	69017	14.96	15.16	380	385	15.94	16.14	405	410	26.06	161.9
SK3-18 Sloped channel - 39.37" (1m)	69018	15.16	15.35	385	390	16.14	16.34	410	415	26.44	163.2
SK3-19 Sloped channel - 39.37" (1m)	69019	15.35	15.55	390	395	16.34	16.54	415	420	26.83	164.6
SK3-20 Sloped channel - 39.37" (1m) <sup>2</sup>	69020	15.55	15.75	395	400	16.54	16.73	420	425	27.21	166.0
<b>SK3-020 Constant depth channel - 39.37" (1m) <sup>2</sup></b>	<b>69044</b>	<b>15.75</b>	<b>15.75</b>	<b>400</b>	<b>400</b>	<b>16.73</b>	<b>16.73</b>	<b>425</b>	<b>425</b>	<b>24.53</b>	<b>166.0</b>
<b>SK3-0203 Constant depth channel - 19.69" (0.5m) <sup>2</sup></b>	<b>69047</b>	<b>15.75</b>	<b>15.75</b>	<b>400</b>	<b>400</b>	<b>16.73</b>	<b>16.73</b>	<b>425</b>	<b>425</b>	<b>12.27</b>	<b>92.0</b>
SK3-21 Sloped channel - 39.37" (1m)	69021	15.75	15.94	400	405	16.73	16.93	425	430	27.59	167.3
SK3-22 Sloped channel - 39.37" (1m)	69022	15.94	16.14	405	410	16.93	17.13	430	435	27.97	168.7
SK3-23 Sloped channel - 39.37" (1m)	69023	16.14	16.34	410	415	17.13	17.32	435	440	28.34	170.1
SK3-24 Sloped channel - 39.37" (1m)	69024	16.34	16.54	415	420	17.32	17.52	440	445	28.72	171.4
SK3-25 Sloped channel - 39.37" (1m) <sup>2</sup>	69025	16.54	16.73	420	425	17.52	17.72	445	450	29.09	172.7
SK3-26 Sloped channel - 39.37" (1m)	69026	16.73	16.93	425	430	17.72	17.91	450	455	29.47	174.2
SK3-27 Sloped channel - 39.37" (1m)	69027	16.93	17.13	430	435	17.91	18.11	455	460	29.84	175.5
SK3-28 Sloped channel - 39.37" (1m)	69028	17.13	17.32	435	440	18.11	18.31	460	465	30.21	176.8
SK3-29 Sloped channel - 39.37" (1m)	69029	17.32	17.52	440	445	18.31	18.50	465	470	30.58	178.3
SK3-30 Sloped channel - 39.37" (1m) <sup>2</sup>	69030	17.52	17.72	445	450	18.50	18.70	470	475	30.95	179.6
<b>SK3-030 Constant depth channel - 39.37" (1m) <sup>2</sup></b>	<b>69046</b>	<b>17.72</b>	<b>17.72</b>	<b>450</b>	<b>450</b>	<b>18.70</b>	<b>18.70</b>	<b>475</b>	<b>475</b>	<b>27.87</b>	<b>179.6</b>
<b>SK3-0303 Constant depth channel - 19.69" (0.5m) <sup>2</sup></b>	<b>69049</b>	<b>17.72</b>	<b>17.72</b>	<b>450</b>	<b>450</b>	<b>18.70</b>	<b>18.70</b>	<b>475</b>	<b>475</b>	<b>13.94</b>	<b>100.0</b>
SK3-31 Sloped channel - 39.37" (1m)	69031	17.72	17.91	450	455	18.70	18.90	475	480	31.32	180.9
SK3-32 Sloped channel - 39.37" (1m)	69032	17.91	18.11	455	460	18.90	19.09	480	485	31.69	182.4
SK3-33 Sloped channel - 39.37" (1m)	69033	18.11	18.31	460	465	19.09	19.29	485	490	32.06	183.7
SK3-34 Sloped channel - 39.37" (1m)	69034	18.31	18.50	465	470	19.29	19.49	490	495	32.42	185.0
SK3-35 Sloped channel - 39.37" (1m) <sup>2</sup>	69035	18.50	18.70	470	475	19.49	19.69	495	500	32.79	186.5
SK3-36 Sloped channel - 39.37" (1m)	69036	18.70	18.90	475	480	19.69	19.88	500	505	33.16	187.8
SK3-37 Sloped channel - 39.37" (1m)	69037	18.90	19.09	480	485	19.88	20.08	505	510	33.52	189.1
SK3-38 Sloped channel - 39.37" (1m)	69038	19.09	19.29	485	490	20.08	20.28	510	515	33.88	190.5
SK3-39 Sloped channel - 39.37" (1m)	69039	19.29	19.49	490	495	20.28	20.47	515	520	34.25	191.9
SK3-40 Sloped channel - 39.37" (1m) <sup>2</sup>	69040	19.49	19.69	495	500	20.47	20.67	520	525	34.61	193.2
<b>SK3-040 Constant depth channel - 39.37" (1m) <sup>2</sup></b>	<b>69048</b>	<b>19.69</b>	<b>19.69</b>	<b>500</b>	<b>500</b>	<b>20.67</b>	<b>20.67</b>	<b>525</b>	<b>525</b>	<b>31.25</b>	<b>193.2</b>
<b>SK3-0403 Constant depth channel - 19.69" (0.5m) <sup>2</sup></b>	<b>69050</b>	<b>19.69</b>	<b>19.69</b>	<b>500</b>	<b>500</b>	<b>20.67</b>	<b>20.67</b>	<b>525</b>	<b>525</b>	<b>15.63</b>	<b>109.0</b>
SK3 Universal closing/inlet/outlet end cap	96827	19.69	19.69	500	500	20.47	20.47	520	520	-	2.5
Installation device	97479	-	-	-	-	-	-	-	-	-	4.9
Grate removal tool	01318	-	-	-	-	-	-	-	-	-	0.3

- Notes:
1. PowerDrain is sold as channel only. Choose appropriate grate from page 94.
  2. Preformed 6" & 8" dia knock-outs cast on underside of certain channel (00, 5, 10, 010, 0103, 15, 20, 020, 0203, 25, 30, 030, 0303, 35, 40, 040, 0403).
  3. Closing/outlet cap can be cut down to suit all channels.
  4. Catch basin details on page 93.

Polymer concrete catch basins

Polymer concrete catch basins are used either as stand alone area drains or more commonly as the outlet to a trench run. They provide the highest hydraulic output and allow easy access to the pipe system for maintenance.

Type 903D and 904D are same width and visually indistinguishable from trench run.

SK3-Type 903D  
12 in. wide In-line catch basin

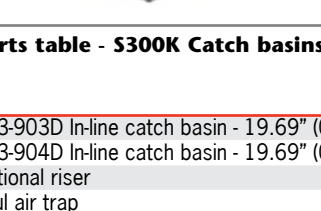
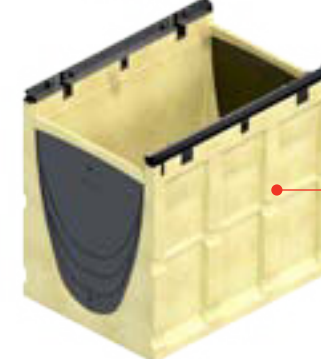
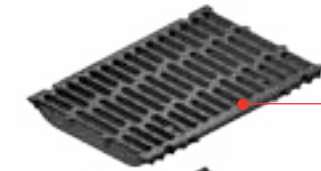

SK3-Type 904D  
12 in. wide In-line catch basin  
(with riser)

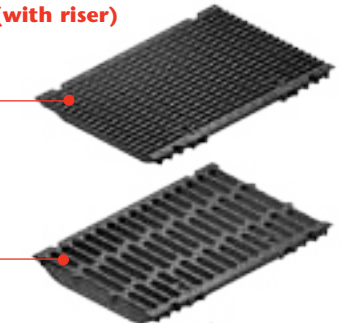

Type 900 grates - choice of Class F slotted or Class E longitudinal ADA compliant ductile iron grates with PowerLok™ boltless locking or Class F slotted ductile iron 4-bolt grate. See page 94.

Top section - polymer concrete with integrally cast-in ductile iron frame for grate. End guides aid connection of male channel ends at #10, 20, 30 and 40 depths. Other channels can be connected by removing wall to correct height. Blanking end rail supplied. See page 155.

Trash bucket - plastic trash bucket designed to collect debris washed from trench run. Supported in catch basin top to avoid creation of a vacuum and reduction in outflow. Use deeper bucket with riser.

Riser - a plastic riser, supplied with SK3-904D, designed to provide additional catch basin depth and hydraulic output. Guides enable cutting to size at 2" (50mm) intervals - minimum 2" and maximum 12" height. Additional units can be used (a maximum of 2 is recommended to ensure snake access is maintained and for structural stability). Contact ACO for non-polyethylene riser.

Base - polyethylene bases with wide range of Schedule 40 4", 6" and 8" cut-outs for easy pipe connection. Cut-outs on end and side allow connection of ACO foul air trap. Contact ACO for non-polyethylene bases.

Parts table - S300K Catch basins

	Part No.	Volume Gallons*	Weight lbs
SK3-903D In-line catch basin - 19.69" (0.5m)	69053	30.4	99.4
SK3-904D In-line catch basin - 19.69" (0.5m)	69054	40.2	104.4
Optional riser	99902	9.8	10.0
Foul air trap	90854	-	1.2

\* Volume is up to grate seat and without trash bucket.

Available S300K grates

Description	Part No.	Length inches (m)	Slot Size inches	Intake area sq. in.	Wgt lbs	Icons
<b>E</b> Load Class E - 135,000lbs - EN1433 <b>2,321psi</b> <b>Industrial</b>						
<b>Longitudinal iron</b>						
Iron	96833	19.69" (0.5m)	0.76 x 0.31	63.2	64.0	PL ✓ ✓ ✓ 48.9
Ductile iron to ASTM A 536-84 - minimum grade 65-45-12						
<b>F</b> Load Class F - 200,000lbs - EN1433 <b>3,481psi</b> <b>Heavy duty</b>						
<b>Slotted iron</b>						
Iron	02445	19.69" (0.5m)	0.71 x 3.61 avg.	122.6	50.0	PL ✗ ✗ ✓ 31.5
Ductile iron to ASTM A 536-84 - minimum grade 65-45-12 This grate complies with RR-F-621E '200,000lb proof load' test.						
<b>4-bolt* iron</b>						
Iron	99592	19.69" (0.5m)	0.71 x 3.75 avg.	115.5	50.2	Bolt ✗ ✗ ✓ 31.5
Ductile iron to ASTM A 536-84 - minimum grade 65-45-12 This grate complies with RR-F-621E '200,000lb proof load' test. * Supplied with 4qty M10 bolts.						

**Key**

- Locking mechanism
- 200,000lb proof load compliant (Page 128)
- Compliant with Americans with Disabilities Act of 1990 Section 4.5.4 (Page 140)
- Bicycle Safe compliant to Australian Standard AS 3996 - 2006 (Page 140)
- ASME A112.6.3 - 2001 Heel resistant less than 0.31" (8mm) (Page 140)
- Anti-slip grates - BPN over 24 (Page 140)

Choosing S300K grates

There are three available grate styles to fit the S300K heavy duty channel body.

The conventional slotted grate, with PowerLok™, gives an excellent all-around heavy duty solution with the ease of the PowerLok™ locking/unlocking mechanism. Ideal for use where regular removal of the grate for maintenance is required.

The ADA compliant, longitudinal slotted grate, with PowerLok™, gives the ideal solution to a heavy duty location where some pedestrian access may be required.

Although easy locking and grate removal is important for maintenance, some specific applications require a 4-bolt solution. The four threaded stainless steel inserts in the S300K channel body allow a 4-bolt grate to be bolted into the channel (using 4qty M10 bolts) for ultimate stiffness and security. Tamper resistant bolts can also be used.



PowerLok™ - boltless locking system



**1**

**Fit grate**

To lock, position side of grate into lugs on rail, place hook part of tool into 'V' and push towards rail.



**2**

**Grate removal**

To open PowerLok™, insert tool between rail and PowerLok™ device.



**3**

**Grate removal**

Rotate tool 90°, PowerLok™ device should push away from rail.

PowerLok™ - safety clip

For areas of extra security or safety concerns, an optional safety clip is available that provides a visual alert if the PowerLok™ devices are left open. The clip push fits next to the PowerLok™ device and sits level with the grate when the grate is locked. The clip cannot be fitted if the PowerLok™ is open. If all grates are engaged, a run of red dots is visible.



4-Bolt grates



**1**

**Fit grate**

Position grate onto channel, align holes in grate with matching holes in edge rail.



**2**

**Fit grate**

Using wrench or socket set to tighten. If using a torque wrench, do not set to more than 15 ft. lbs.



**3**

**Grate removal**

To remove grates, use wrench or socket set. Carefully store bolts for refitting of grates.

Grate accessories

	Part No.	Weight lbs
PowerLok safety clip (red)	10443	0.1
Replacement bolt for 4-bolt grate	95526	0.1
Tamper resistant bolt for 4-bolt grate	138127	0.1
Tamper resistant bolt drive	138128	0.1



Requires tamper resistant drive bit