

TECH-SPEC:

Product Reference Sheet

1806I_NB

Example: **1806I** | **C** | **NB** | **36**
 Profile# Finish Insert Length

CATEGORY: Brush Gasketing

TYPE: Door Bottom

FINISHES: C (Clear Anodized), D (Dark Anodized), G (Gold Anodized), PW (Painted White)

WIDTH: 1/4" (6.4 mm)

HEIGHT: 1-3/8" (34.925 mm)

WEIGHT: .12 lbs.

RATINGS:   

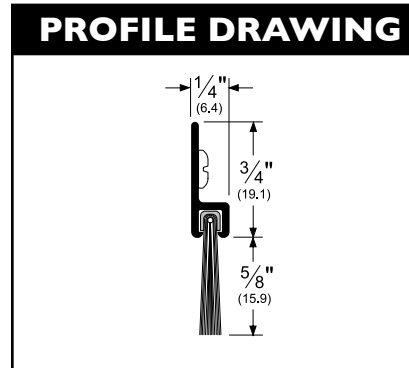

PRODUCT APPROVALS:

- Tested and approved under UL10C for Fire; UL1784 for Smoke
- BHMA A156.22
- Category J and H gaskets for use with classified steel covered composite, hollow metal doors rated up to and including 3 hours; wood and plastic covered composite doors rated up to and including 1-1/2 hours; and wood core doors rated for 20 minutes without hose stream.

LEAD TIME: 4 working days (or less).

AVAILABLE: Ships from the Memphis, TN, and Ventura, CA location.

CROSS REFERENCE: NGP: 600, 9600, B606, or C607; Reese: 964; Hager: 802, Crowder: W25, Draftseal: DS148

INSTRUCTIONS: Available upon request (and on website).

CAD DRAWINGS: Available upon request (and on website).

PROFILE DRAWINGS: Available upon request (and on website).

CUT SHEET: Available upon request (and on website).

www.pemko.com

Memphis, TN USA
 P.O. Box 18966
 Memphis, TN 38181
 P: 800.824.3018
 F: 800.243.3656

Ventura, CA USA
 P.O. Box 3780
 Ventura, CA 93006
 P: 800.283.9988
 F: 800.283.4050

Vancouver, BC Canada
 103-2480 Mt. Lehman Rd.
 Abbotsford, BC V2T 6W3
 P: 877.535.7888
 F: 877.535.7444

Toronto, ON Canada
 160 Four Valley Dr.
 Vaughan, ON L4K 4T9
 P: 877.535.7888
 F: 877.535.7444