



PHR5

Product Specifications

UP to 15.5 SEER, UP to 12.5 EER, PACKAGE HEAT PUMP UNITS, 2 – 5 TONS

208/230 Volt, 1-phase, 60 Hz

208/230 Volt, 3-phase, 60 Hz

REFRIGERATION CIRCUIT

- Environmentally balanced R-410A refrigerant
- Copper tube/aluminum fin condenser and evaporator coils
- Tin-plated copper evaporator coil standard (single-phase only)
- Enhanced dehumidification feature on high stage cooling with use of a dehumidistat
- Two stage scroll compressors standard on all models

EASY TO INSTALL AND SERVICE

- Installs easily on a rooftop or at ground level
- Easy three-panel accessibility for maintenance and installation
- Easily converts to down discharge applications

BUILT TO LAST

- Hail guard (3/8" spacing) wire grilles standard
- Multi-speed ECM blower motor standard on all models
- Pre-painted steel cabinet
- Vertical condenser fan discharge
- Full perimeter steel base rails
- High and low pressure switches provide added reliability for the compressor
- Cabinet air leakage of 2.0% or less at .5 in. W.C. when tested in accordance with ASHRAE standard 193 (Low cabinet air leakage FIOP models only)

Models with factory installed options are identified with letters in the 11th and 12th positions in the model number

- Single and 3-phase models with factory installed option for low cabinet air leakage and tin-plated copper evaporator main tubes (LC)
- Single phase models with factory installed tin-plated copper evaporator main tubes (TP)

LIMITED WARRANTY*

- 5 year No Hassle Replacement limited warranty (Single-phase only)
- 5 year parts limited warranty (including compressor and coils)
 - With timely registration, an additional 5 year parts limited warranty, including compressor and coils (Single-phase only)

* For residential applications only. See warranty certificate for complete details and restrictions, including warranty coverage for other applications.



As an Energy Star® Partner, International Comfort Products has determined that this product meets the ENERGY STAR® guidelines for energy efficiency.



Use of the AHRI Certified TM Mark indicates a manufacturer's participation in the program. For verification of certification for individual products, go to www.ahridirectory.org.

UNIT PERFORMANCE DATA

Model Number	COOLING				HSPF	COP	Unit Dimensions Height x Width x Depth Inches (mm)	Operating Weight lbs / kg
	Net Capacity BTU/h High Stage	Standard CFM High / Low Stage	SEER	EER				
PHR524000K**0B	22800	855/675	15.0	12.0	8.2	3.9	51-3/4 x 47 x 32-5/8 (1315 x 1194 x 829)	338/153
PHR530000‡**0B	29400	1000/775	15.0	12.0	8.2	3.7	51-3/4 x 47 x 32-5/8 (1315 x 1194 x 829)	384/174
PHR536000‡**0A	34000	1200/900	15.0	12.0	8.2	3.7	44-3/4 x 48-1/4 x 44-3/16 (1237 x 1226 x 1122)	413/187
PHR542000‡**0A	42000	1400/1050	15.0	12.0	8.2	3.6	50-3/4 x 48-1/4 x 44-3/16 (1289 x 1226 x 1122)	444/201
PHR548000‡**0A	47500	1600/1200	15.5	12.5	8.2	3.7	48-3/4 x 48-1/4 x 44-3/16 (1238 x 1226 x 1122)	447/203
PHR560000‡**0A	57000	1750/1400	15.0	12.0	8.5	3.5	54-3/4 x 48-1/4 x 44-3/16 (1391 x 1226 x 1122)	503/228

‡ K = 208/230-1-60, H = 208/230-3-60

** 00 = Standard (3-phase), LC = Low cabinet air leakage plus Tin-Plated Copper Evaporator Main Tubes, TP = Tin-Plated Evaporator Main Tubes plus Stainless Steel Heat Exchanger (single phase)

MODEL NOMENCLATURE										
	1	2	3,4	5,6	7,8,9	10	11,12	13	14	15
MODEL SERIES	P	H	R5	36	000	K	00	0	A or B	1
P = Package										
H = Heat Pump										
R5 = Mainline			TIER							
24 = 24,000 BTUH = 2 Tons										
30 = 30,000 BTUH = 2.5 Tons										
36 = 36,000 BTUH = 3 Tons										
42 = 42,000 BTUH = 3.5 Tons										
48 = 48,000 BTUH = 4 Tons										
60 = 60,000 BTUH = 5 Tons										
000 = no factory heat				NOMINAL CLG CAPACITY	NOMINAL HTG BTUH (input)					
K = 208/230-1-60						VOLTAGE				
H = 208/230-3-60										
00 = No options										
LC = Low Cabinet Air Leakage plus Tin-Plated Copper Evap Main Tubes										
TP = Tin-Plated Evaporator Main Tubes										
0 = Standard										
Sales Model Digit										
Engineering Digit										
									FACTORY INSTALLED OPTIONS	
										FEATURE CODE

A-WEIGHTED SOUND POWER LEVEL (dBA)								
Model PHR5	Sound Ratings (dBA)	TYPICAL OCTAVE BAND SPECTRUM (dBA without tone adjustment)						
		125	250	500	1000	2000	4000	8000
24	68	77	65	65	63	57	52	48
30	69	70	66	67	65	58	56	54
36	73	64	63.5	68	68	65.5	60.5	52.5
42	71	64	62	65	66	63.5	59.5	52.5
48	74	59.5	65	70	67	64.5	60.5	52.5
60	73	68	63	66	66	65	59.5	52.5

NOTE: Tested in accordance with AHRI Standard 270-1995 (not listed in AHRI).

UNIT SPECIFICATIONS						
UNIT SIZE	24	30	36	42	48	60
NOMINAL CAPACITY (ton)	2	2-1/2	3	3-1/2	4	5
SHIPPING WEIGHT lb.	347	393	420	466	462	511
SHIPPING WEIGHT (kg)	157	178	191	212	210	232
COMPRESSORS	Scroll					
Quantity	1					
REFRIGERANT (R-410A)						
Quantity lb	8.2	11.2	11.0	14.6	12.0	14.8
Quantity (kg)	3.7	5.1	5.0	6.6	5.4	6.7
REFRIGERANT METERING DEVICE	TXV, Indoor TXV					
ORIFICE - OUTDOOR COIL						
ID (in.)	.032 (2)	.035 (1) .038 (1)	.042 (2)	.042 (2)	.042 (2)	.052 (2)
ID (mm)	0.81 (2)	.89 (1) .97 (1)	1.07 (2)	1.07 (2)	1.07 (2)	1.32 (2)
OUTDOOR COIL						
Rows...Fins/in.	1...21	2...21	2...21	2...21	2...21	2...21
Face Area (sq ft)	18.8	18.8	13.6	19.4	17.5	23.3
OUTDOOR FAN						
Nominal Cfm	2100	2500	3000	3000	3300	3600
Diameter in.	24	24	26	26	26	26
Diameter (mm)	609.6	609.6	660.4	660.4	660.4	660.4
Motor Hp (Rpm)	1/12 (800)	1/8 (810)	1/5 (810)	1/5 (810)	1/5 (810)	1/5 (810)
INDOOR COIL						
Rows...Fins/in.	3...17	3...17	3...17	3...17	3...17	4...17
Face Area (sq ft)	3.7	3.7	4.7	4.7	5.7	5.7
INDOOR BLOWER						
Nominal Low Stage Cooling Airflow (Cfm)	675	775	900	1050	1200	1400
Nominal High Stage Cooling Airflow (Cfm)	855	1000	1200	1400	1600	1750
Size in.	10x10	10x10	11x10	11x10	11x10	11x10
Size (mm.)	254x254	254x254	279.4x254	279.4x254	279.4x254	279.4x254
Motor HP (RPM)	1/2 (1050)	1/2 (1050)	3/4 (1000)	3/4 (1075)	1.0 (1075)	1.0 (1075)
HIGH-PRESSURE SWITCH (psig) Cut-out Reset (Auto)	650 +/- 15 420 +/- 25					
LOW-PRESSURE SWITCH (psig) cut-out Reset (auto)	20 +/- 5 45 +/- 5					
RETURN-AIR FILTERS†‡						
Throwaway Size in.	20x20x1	20x24x1	24x30x1	24x36x1		
Throwaway Size (mm)	508x508x25	508x610x25	610x762x25	610x914x25		

† Required filter sizes shown are based on the larger of the AHRI (Air Conditioning Heating and Refrigeration Institute) rated cooling airflow or the heating airflow velocity of 300 ft/minute for throwaway type or 450 ft/minute for high-capacity type. Air filter pressure drop for non-standard filters must not exceed 0.08 in. W.C.

‡ If using accessory filter rack refer to the filter rack installation instructions for correct filter sizes and quantity.

OPTIONS AND ACCESSORIES

ITEM	DESCRIPTION	FACTORY INSTALLED OPTION	FIELD INSTALLED ACCESSORY
Coil Options	Base unit with tin plated indoor coil hairpins	X	
Compressor Start Kit	Compressor Start Kit assists compressor start-up by providing additional starting torque on sing phase units only.		X
Corporate Thermostats	Thermostats provide control for the system heating and cooling functions.		X
Crankcase Heater	Crankcase Heater provides anti-floodback protection for low-load cooling applications.		X*
Economizer	Vertical Economizer with solid state controls and barometric relief dampers includes filter racks and provide outdoor air during cooling and reduce compressor operation.		X
	Horizontal Economizer with solid state controls and barometric relief dampers includes filter racks and provide outdoor air during cooling and reduce compressor operation.		X
Electric Heaters	Electric Heat Supplement		X
Filter Rack	Filter Rack features easy installation, serviceability, and high-filtering performance for vertical applications. Includes 1-in. filter.	X	X
Flat Roof Curb	14-in. (356 mm) Flat Roof Curb is available for roof mounted applications.		X
Low Ambient Kit	Low Ambient Kit (Motormaster II Control) allows the use of mechanical cooling down to outdoor temperatures as low as 0°F (-18°C) when properly installed.		X
Manual Outside Air Damper	Manual Outside Air Damper includes hood and filter rack with adjustable damper blade for up to 25% outdoor air.		X
Square-to-Round Duct Transition Kit	Square-to-Round Duct Transition Kit enable 24-48 size units to be fitted to 14 in (356 mm). round ductwork.		X
Low Cabinet Air Leakage	Cabinet air leakage of 2.0% or less at .5 in. W.C. when tested in accordance with ASHRAE standard 193.	X	
Dual Point Electric Heaters	Allows you to power the electric heater and unit contactor separately by having two individual field power supply circuits connected respectively.		X

UNIT AIRFLOW – DRY COIL AIR DELIVERY* – HORIZONTAL AND DOWNFLOW DISCHARGE

UNIT PHR5	MOTOR SPEED	WIRE COLOR		EXTERNAL STATIC PRESSURE (IN. W.C.)									
				0.1	0.2	0.3	0.4	0.5	0.6	0.7	0.8	0.9	1.0
PHR524	Low ¹	Blue	CFM	777	692	583	465	318	---	---	---	---	---
			BHP	0.09	0.10	0.10	0.11	0.12	---	---	---	---	---
	Med-Low	Pink	CFM	877	779	698	598	519	410	---	---	---	---
			BHP	0.12	0.12	0.13	0.14	0.15	0.15	---	---	---	---
	Medium ²	Red	CFM	904	841	769	705	628	522	372	---	---	---
			BHP	0.16	0.17	0.17	0.18	0.19	0.19	0.20	---	---	---
	Med-High	Orange	CFM	1229	1171	1105	1049	980	913	838	775	679	516
			BHP	0.28	0.30	0.30	0.31	0.32	0.33	0.33	0.34	0.34	0.33
	High	Black	CFM	1291	1206	1142	1081	1017	951	888	823	753	668
			BHP	0.31	0.32	0.33	0.34	0.34	0.35	0.36	0.36	0.37	0.37
PHR530	Low	Blue	CFM	777	692	583	465	318	---	---	---	---	---
			BHP	0.09	0.10	0.10	0.11	0.12	---	---	---	---	---
	Med-Low ¹	Pink	CFM	831	765	670	586	466	299	---	---	---	---
			BHP	0.11	0.12	0.12	0.13	0.13	0.14	---	---	---	---
	Medium ²	Red	CFM	1139	1069	1012	937	870	786	724	626	512	381
			BHP	0.22	0.23	0.24	0.24	0.25	0.26	0.26	0.27	0.27	0.28
	Med-High	Orange	CFM	1229	1171	1105	1049	980	913	838	775	679	516
			BHP	0.28	0.30	0.30	0.31	0.32	0.33	0.33	0.34	0.34	0.33
	High	Black	CFM	1531	1460	1382	1301	1209	1114	1003	890	764	629
			BHP	0.53	0.52	0.50	0.48	0.46	0.44	0.42	0.40	0.37	0.35
PHR536	Low	Blue	CFM	1097	971	823	747	669	636	558	513	456	412
			BHP	0.12	0.11	0.10	0.11	0.12	0.13	0.13	0.14	0.15	0.16
	Med-Low ¹	Pink	CFM	934	864	810	745	698	649	571	525	486	428
			BHP	0.10	0.10	0.11	0.12	0.13	0.14	0.14	0.15	0.16	0.17
	Medium ²	Red	CFM	1251	1198	1149	1104	1066	1017	970	932	892	839
			BHP	0.19	0.21	0.21	0.23	0.24	0.25	0.26	0.27	0.28	0.29
	Med-High	Orange	CFM	1451	1415	1372	1327	1287	1249	1212	1168	1130	1094
			BHP	0.29	0.30	0.31	0.32	248.59	0.35	0.36	0.37	0.38	0.39
	High	Black	CFM	1466	1423	1384	1343	1308	1263	1219	1183	1145	1106
			BHP	0.30	0.31	0.33	0.34	0.35	0.36	0.37	0.38	0.40	0.41
PHR542	Low	Blue	CFM	1097	971	823	747	669	636	558	513	456	412
			BHP	0.12	0.11	0.10	0.11	0.12	0.13	0.13	0.14	0.15	0.16
	Med-Low ¹	Pink	CFM	1076	1026	972	918	872	827	771	714	666	611
			BHP	0.13	0.14	0.15	0.15	0.17	0.18	0.18	0.20	0.21	0.22
	Medium	Red	CFM	1251	1198	1149	1104	1066	1017	970	932	892	839
			BHP	0.19	0.21	0.21	0.23	0.24	0.25	0.26	0.27	0.28	0.29
	Med-High ²	Orange	CFM	1451	1415	1372	1327	1287	1249	1212	1168	1130	1094
			BHP	0.29	0.30	0.31	0.32	248.59	0.35	0.36	0.37	0.38	0.39
	High	Black	CFM	1633	1590	1552	1518	1483	1444	1406	1372	1340	1303
			BHP	0.41	0.43	0.44	0.45	0.47	0.48	0.49	0.50	0.51	0.53
PHR548	Low ¹	Blue	CFM	1271	1229	1177	1121	1066	1027	974	942	887	839
			BHP	0.19	0.20	0.21	0.23	0.24	0.25	0.26	0.27	0.28	0.29
	Med-Low	Pink	CFM	1340	1299	1240	1191	1139	1091	1050	1001	952	895
			BHP	0.22	0.23	0.24	0.25	0.26	0.28	0.29	0.30	0.31	0.32
	Medium ²	Red	CFM	1686	1650	1617	1576	1544	1503	1468	1433	1393	1356
			BHP	0.42	0.44	0.45	0.46	0.48	0.49	0.51	0.52	0.53	0.55
	Med-High	Orange	CFM	1854	1837	1781	1784	1720	1698	1655	1625	1578	1532
			BHP	0.56	0.57	0.60	0.59	0.62	0.63	0.64	0.66	0.67	0.67
	High	Black	CFM	1934	1900	1855	1815	1778	1737	1695	1656	1606	1528
			BHP	0.59	0.61	0.62	0.64	0.65	0.67	0.68	0.70	0.70	0.68
PHR560	Low	Blue	CFM	1182	1137	1102	1053	1012	966	920	868	830	783
			BHP	0.21	0.22	0.23	0.24	0.25	0.26	0.27	0.28	0.30	0.31
	Med-Low ¹	Pink	CFM	1454	1405	1364	1316	1281	1234	1198	1147	1105	1056
			BHP	0.34	0.35	0.36	0.37	0.38	0.40	0.41	0.42	0.43	0.45
	Medium ²	Red	CFM	1818	1770	1731	1693	1657	1621	1579	1546	1505	1436
			BHP	0.56	0.57	0.59	0.60	0.62	0.63	0.64	0.66	0.67	0.66
	Med-High	Orange	CFM	1881	1849	1818	1793	1763	1729	1679	1610	1523	1479
			BHP	0.67	0.69	0.70	0.71	0.72	0.73	0.73	0.71	0.68	0.65
	High	Black	CFM	2138	2084	2025	1967	1893	1829	1754	1678	1591	1475
			BHP	0.98	0.95	0.93	0.90	0.86	0.84	0.80	0.76	0.74	0.68

* Air delivery values are without air filter and are for dry coil (See PHR5-A Wet Coil Pressure Drop table).

¹ Factory-shipped low stage cooling speed.

² Factory-shipped high stage cooling speed.

Note: Deduct field-supplied air filter pressure drop and wet coil pressure drop to obtain external static pressure available for ducting.

Shaded areas indicate acceptable Dehum. Speeds (Dehum. Mode is High Stage Only, 208/230 VAC Models Only).

WET COIL PRESSURE DROP (IN. W.C.)

UNIT SIZE	STANDARD CFM (SCFM)																
	600	700	800	900	1000	1100	1200	1300	1400	1500	1600	1700	1800	1900	2000	2100	2200
24	0.03	0.04	0.05	0.06	0.07												
30				0.06	0.07	0.07	0.08	0.09									
36				0.06	0.07	0.08	0.09	0.10	0.11								
42					0.07	0.08	0.09	0.10	0.11	0.11	0.12	0.12					
48							0.03	0.04	0.08	0.08	0.10	0.11	0.14	0.15	0.16		
60										0.08	0.10	0.11	0.14	0.15	0.16	0.16	

ECONOMIZER WITH 1-IN. FILTER PRESSURE DROP (IN. W.C.)

FILTER SIZE IN. (MM)	CLG TONS	STANDARD CFM (SCFM)																
		600	700	800	900	1000	1100	1200	1300	1400	1500	1600	1700	1800	1900	2000	2100	2200
600-1400CFM 12x20x1+12x20x1 (305x508x25+305x508x25)	2.0, 2.5	-	-	0.09	0.14	0.16	0.18	0.25	0.28	0.3	-	-	-	-	-	-	-	
1200-1800 CFM 16x24x1+14x24x1 (406x610x25+356x610x25)	3.0, 3.5	-	-	-	-	-	-	0.10	0.11	0.12	0.13	0.14	0.16	0.16	-	-	-	
1500-2200 CFM 16x24x1+18x24x1 (406x610x25+457x610x25)	4.0 5.0	-	-	-	-	-	-	-	-	-	0.15	0.17	0.18	0.20	0.21	0.22	0.23	0.23

FILTER PRESSURE DROP TABLE (IN. W.C.)

FILTER SIZE IN. (MM)	CLG TONS	STANDARD CFM (SCFM)																
		600	700	800	900	1000	1100	1200	1300	1400	1500	1600	1700	1800	1900	2000	2100	2200
600-1400CFM 12x20x1+12x20x1 (305x508x25+305x508x25)	2.0, 2.5	0.03	0.05	0.06	0.08	0.10	0.11	0.13	0.14	0.16	-	-	-	-	-	-	-	-
1200-1800 CFM 16x24x1+14x24x1 (406x610x25+356x610x25)	3.0, 3.5	-	-	-	-	-	-	0.07	0.08	0.09	0.09	0.10	0.11	0.12	-	-	-	-
1500-2200 CFM 16x24x1+18x24x1 (406x610x25+457x610x25)	4.0 5.0	-	-	-	-	-	-	-	-	-	0.04	0.06	0.08	0.10	0.11	0.13	0.14	0.15

ELECTRIC HEAT PRESSURE DROP TABLES (IN. W.C.)

Small Cabinet: 24-30

STATIC	STANDARD CFM (SCFM)											
	500	600	700	800	900	1000	1100	1200	1300	1400	1500	1600
5 kW	0.00	0.00	0.00	0.00	0.00	0.00	0.00	0.00	0.02	0.04	0.06	0.07
10 kW	0.00	0.00	0.00	0.00	0.00	0.02	0.04	0.06	0.07	0.09	0.10	0.11
15 kW	0.00	0.00	0.00	0.02	0.04	0.06	0.08	0.10	0.12	0.14	0.16	0.18
20 kW	0.00	0.00	0.02	0.04	0.06	0.08	0.09	0.11	0.13	0.15	0.17	0.19

Large Cabinet: 36-60

STATIC	STANDARD CFM (SCFM)														
	1100	1200	1300	1400	1500	1600	1700	1800	1900	2000	2100	2200	2300	2400	2500
5 kW	0.00	0.00	0.00	0.01	0.02	0.03	0.04	0.05	0.06	0.07	0.08	0.09	0.10	0.11	0.12
10 kW	0.00	0.00	0.01	0.02	0.03	0.04	0.05	0.06	0.07	0.08	0.09	0.10	0.11	0.12	0.13
15 kW	0.00	0.02	0.03	0.04	0.05	0.06	0.07	0.08	0.09	0.10	0.11	0.12	0.13	0.14	0.15
20 kW	0.02	0.03	0.04	0.05	0.06	0.07	0.08	0.09	0.10	0.11	0.12	0.13	0.14	0.15	0.16

MINIMUM AIRFLOW FOR SAFE ELECTRIC HEATER OPERATION (CFM)

SIZE	24	30	36	42	48	60
Cfm	850	1000	1200	1400	1600	1750

MULTIPLICATION FACTORS

HEATER kW RATING	VOLTAGE DISTRIBUTION V/3/60	MULTIPLICATION FACTOR
240	200	0.69
	208	0.75
	230	0.92
	240	1.00

ELECTRICAL DATA											
UNIT	NOMINAL	VOLTAGE RANGE		COMPRESSOR		OFM	IFM	ELECTRIC HEAT		POWER SUPPLY	
		MIN	MAX	RLA	LRA	FLA	FLA	NOMINAL kW	FLA	MCA	MOCP
PHR524000K	208/230-1-60	197	253	11.7	58.3	0.6	4.1	-/-	-/-	19.3	30
								3.8/5	18.1/20.8	42/45.3	45/50
								5.4/7.2	25.9/30	51.7/56.8	60/60
								7.5/10	36.1/41.7	64.5/71.5	70/80
PHR530000K	208/230-1-60	197	253	13.4	73.0	0.9	4.1	-/-	-/-	21.8	30
								3.8/5	18.1/20.8	44.4/47.5	45/50
								5.4/7.2	25.9/30	54.1/59.3	60/60
								7.5/10	36.1/41.7	66.9/73.9	70/80
PHR530000H	208/230-3-60	197	253	9.0	58.0	0.9	4.1	-/-	-/-	16.3	20
								3.8/5	10.4/12	29.3/31.3	30/35
								7.5/10	20.8/24.1	42.3/46.4	45/50
								11.3/15	31.2/36.1	55.3/61.4	60/70
PHR536000K	208/230-1-60	197	253	15.3	83.0	1.2	6.0	-/-	-/-	26.3	40
								3.8/5	18.1/20.8	49/52.3	50/60
								5.4/7.2	25.9/30	58.7/63.8	60/70
								7.5/10	36.1/41.7	71.5/78.5	80/80
PHR536000H	208/230-3-60	197	253	11.6	73.0	1.2	6.0	-/-	-/-	21.7	30
								3.8/5	10.4/12	34.7/36.7	35/40
								7.5/10	20.8/24.1	47.7/51.8	50/60
								11.3/15	31.2/36.1	60.7/66.8	70/70
PHR542000K	208/230-1-60	197	253	20.4	96.0	1.2	6.0	-/-	-/-	32.7	45
								3.8/5	18.1/20.8	55.3/58.7	60/60
								5.4/7.2	25.9/30	65.1/70.2	70/80
								7.5/10	36.1/41.7	77.8/84.8	80/90
								11.3/15	54.2/62.5	100.5/110.8	110/125
								15/20	72.2/83.3	123/136.8	125/150
PHR542000H	208/230-3-60	197	253	14.2	88.0	1.2	6.0	-/-	-/-	25	35
								3.8/5	10.4/12	38/40	40/40
								7.5/10	20.8/24.1	51/55.1	60/60
								11.3/15	31.2/36.1	64/70.1	70/80
								15/20	41.4/47.9	76.7/84.8	80/90
PHR548000K	208/230-1-60	197	253	21.2	104.0	1.2	7.6	-/-	-/-	35.3	50
								3.8/5	18.1/20.8	57.9/61.3	60/70
								5.4/7.2	25.9/30	67.7/72.8	70/80
								7.5/10	36.1/41.7	80.4/87.4	90/90
								11.3/15	54.2/62.5	103.1/113.4	110/125
PHR548000H	208/230-3-60	197	253	14.0	83.1	1.2	7.6	-/-	-/-	26.3	40
								3.8/5	10.4/12	39.3/41.3	40/45
								7.5/10	20.8/24.1	52.3/56.4	60/60
								11.3/15	31.2/36.1	65.3/71.4	70/80
								15/20	41.4/47.9	78.1/86.2	80/90
PHR560000K	208/230-1-60	197	253	28.8	152.9	1.2	7.6	-/-	-/-	44.8	60
								3.8/5	18.1/20.8	67.4/70.8	70/80
								5.4/7.2	25.9/30	77.2/82.3	80/90
								7.5/10	36.1/41.7	89.9/96.9	90/100
								11.3/15	54.2/62.5	112.6/122.9	125/125
PHR560000H	208/230-3-60	197	253	16.2	110.0	1.2	7.6	-/-	-/-	29.1	40
								3.8/5	10.4/12	42.1/44.1	45/45
								7.5/10	20.8/24.1	55.1/59.2	60/60
								11.3/15	31.2/36.1	68.1/74.2	70/80
								15/20	41.4/47.9	80.8/88.9	90/90

LEGEND
FLA = Full Load Amps
LRA = Locked Rotor Amps
MCA = Minimum Circuit Ampacity
MOCP = Maximum Overcurrent Protection
RLA = Rated Load Amps

LEGEND

- FLA - Full Load Amps
- IDM - Inducer Motor
- IFM - Indoor Fan Motor
- LRA - Locked Rotor Amps
- MCA - Minimum Circuit Amps
- MOCP - Maximum Over Current Protection
- OFM - Outdoor Fan Motor
- RLA - Rated Load Amps

NOTES:

1. In compliance with NEC (National Electrical Code) requirements for multimotor and combination load equipment (refer to NEC Articles 430 and 440), the overcurrent protective device for the unit shall be Power Supply fuse or circuit breaker.
2. Minimum wire size is based on 60 C copper wire. If other than 60 C wire is used, or if length exceeds wire length in table, determine size from NEC.
3. Unbalanced 3-Phase Supply Voltage
Never operate a motor where a phase imbalance in supply voltage is greater than 2%. Use the following formula to determine the percentage of voltage imbalance

$$\% \text{ Voltage Imbalance} = 100 \times \frac{\text{max voltage deviation from average voltage}}{\text{average voltage}}$$

EXAMPLE: Supply voltage is 230-3-60.

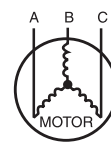

$$\begin{aligned} AB &= 228 \text{ v} \\ BC &= 231 \text{ v} \\ AC &= 227 \text{ v} \\ \text{Average Voltage} &= \frac{228 + 231 + 227}{3} \\ &= \frac{686}{3} \\ &= 229 \end{aligned}$$

Determine maximum deviation from average voltage.

$$\begin{aligned} (AB) \ 229 - 228 &= 1 \text{ v} \\ (BC) \ 231 - 229 &= 2 \text{ v} \\ (AC) \ 229 - 227 &= 2 \text{ v} \end{aligned}$$

Maximum deviation is 2 v.

Determine percent of voltage imbalance

$$\begin{aligned} \% \text{ Voltage Imbalance} &= 100 \times \frac{2}{229} \\ &= 0.8\% \end{aligned}$$

This amount of phase imbalance is satisfactory as it is below the maximum allowable 2%.

IMPORTANT: If the supply voltage phase imbalance is more than 2%, contact your local electric utility company immediately.

A06564

AHRI* CAPACITIES

COOLING CAPACITIES AND EFFICIENCIES

Unit Model	Nominal Tons	Standard CFM (High / Low Stage)	Net Cooling Capacities - Btu/h (High Stage)	EER @A**	SEER†
24	2	855 / 675	22,800	12.0	15.0
30	2-1/2	1000 / 775	29,400	12.0	15.0
36	3	1200 / 900	34,000	12.0	15.0
42	3-1/2	1400 / 1050	42,000	12.0	15.0
48	4	1600 / 1200	47,500	12.5	15.5
60	5	1750 / 1400	57,000	12.0	15.0

LEGEND

- dB—Sound Levels (decibels)
- db—Dry Bulb
- SEER—Seasonal Energy Efficiency Ratio
- wb—Wet Bulb
- COP—Coefficient of Performance

* Air Conditioning, Heating & Refrigeration Institute.

**At "A" conditions—80°F (26.7°C) indoor db/67°F (19.4°C) indoor wb & 95°F (35°C) outdoor db.

† Rated in accordance with U.S. Government DOE Department of Energy test procedures and/or AHRI Standards 210/240.

Notes:

1. Ratings are net values, reflecting the effects of circulating fan heat.

Ratings are based on:

Cooling Standard: 80°F (26.7°C) db, 67°F wb (19.4°C) indoor entering—air temperature and 95°F db (35°C) outdoor entering—air temperature.

2. Before purchasing this appliance, read important energy cost and efficiency information available from AHRI directory.org.

Unit Model	Heating Capacity (BTUH) @ 47°F (8.3°C)	COP @ 47°F (8.3°C)	Heating Capacity (BTUH) @ 17°F (8.3°C)	COP @ 17°F (8.3°C)	HSPF	Heating Cd
24	23,400	3.9	12,200	2.3	8.2	0.25
30	30,000	3.7	16,200	2.3	8.2	0.25
36	34,000	3.7	17,200	2.3	8.2	0.25
42	42,000	3.6	24,000	2.5	8.2	0.25
48	47,500	3.7	26,000	2.3	8.2	0.25
60	57,000	3.5	32,400	2.4	8.5	0.25

PHR524 EXTENDED COOLING PERFORMANCE – LOW COOL

CFM		CONDENSER ENTERING AIR TEMPERATURES deg F, Dry Bulb																																																	
		75 (23.8°C)						85 (29.4°C)						95 (35°C)						105 (40.5°C)						115 (46.1°C)																									
		57	62	63††	67	72	72	57	62	63††	67	72	72	57	62	63††	67	72	72	57	62	63††	67	72	72	57	62	63††	67	72	72																				
525	MBH†	18.15	18.61	18.94	20.32	22.23	17.65	17.93	18.25	19.55	21.38	16.95	17.04	17.37	18.63	20.38	16.00	16.03	16.17	17.55	19.27	14.98	15.00	14.86	16.22	18.06	1.00	0.94	0.75	0.72	0.53	1.00	0.96	0.76	0.74	0.54	1.00	0.99	0.78	0.76	0.55	1.00	1.00	0.80	0.78	0.56	1.00	1.00	0.80	0.78	0.56
	S/T‡	4.59	4.58	4.57	4.54	4.50	5.18	5.18	5.17	5.15	5.12	5.85	5.85	5.84	5.84	5.82	6.62	6.62	6.62	6.61	6.62	6.62	6.62	6.61	6.62	6.62	7.51	7.51	7.52	7.52	7.50	7.52	7.52	7.52	7.52	7.50	7.52	7.52	7.52	7.52	7.50										
	AMPS*	268	269	270	273	278	310	311	311	315	321	355	355	356	361	367	405	405	406	410	418	462	462	461	466	472	462	462	461	466	472	462	462	461	466	472															
	HI PR	130	133	134	143	154	135	137	138	147	158	140	141	143	152	163	145	145	146	156	168	150	150	148	159	173	150	150	148	159	173	150	150	148	159	173															
	LO PR	19.64	19.85	19.76	21.20	23.17	19.04	19.07	18.98	20.33	22.22	18.28	18.31	18.01	19.31	21.11	17.36	17.38	16.80	18.14	19.91	16.24	16.27	15.42	16.79	18.61	1.00	0.95	0.81	0.79	0.57	1.00	1.00	0.86	0.84	0.59	1.00	1.00	0.89	0.87	0.61	1.00	1.00	0.94	0.91	0.63					
675	S/T‡	4.61	4.61	4.61	4.58	4.53	5.22	5.21	5.22	5.19	5.15	5.90	5.90	5.90	5.88	5.87	6.67	6.67	6.67	6.67	6.67	6.67	6.67	6.67	6.67	6.67	7.57	7.57	7.57	7.57	7.56	7.57	7.57	7.57	7.57	7.56															
	AMPS*	271	272	272	275	280	314	314	313	317	323	360	360	359	363	369	410	410	410	408	413	466	466	466	463	474	466	466	466	463	474	466	466	466	463	474															
	HI PR	140	141	140	149	160	145	145	144	153	164	150	150	148	157	169	155	156	151	161	173	160	160	160	153	164	160	160	160	153	164	160	160	160	153	164															
	LO PR	19.85	20.11	19.86	21.32	23.29	19.23	19.26	19.07	20.44	22.33	18.46	18.49	18.09	19.39	21.20	17.54	17.56	16.88	18.22	19.98	16.41	16.44	15.49	16.87	18.68	1.00	0.93	0.83	0.80	0.57	1.00	1.00	0.88	0.85	0.60	1.00	1.00	0.91	0.89	0.62	1.00	1.00	0.95	0.92	0.64					
	S/T‡	4.62	4.61	4.62	4.58	4.54	5.22	5.22	5.22	5.20	5.16	5.90	5.90	5.91	5.89	5.87	6.68	6.68	6.68	6.68	6.68	6.68	6.68	6.68	6.68	6.68	7.58	7.58	7.58	7.58	7.57	7.58	7.58	7.58	7.58	7.57															
AMPS*	272	273	272	275	280	314	314	314	318	323	361	361	359	364	369	411	411	411	408	413	466	466	467	464	475	466	466	467	464	475	466	466	467	464	475																
HI PR	141	143	141	150	161	146	146	144	154	165	151	152	148	158	170	157	157	152	162	174	162	162	162	154	165	162	162	162	154	165	162	162	162	154	165																
LO PR	19.85	20.11	19.86	21.32	23.29	19.23	19.26	19.07	20.44	22.33	18.46	18.49	18.09	19.39	21.20	17.54	17.56	16.88	18.22	19.98	16.41	16.44	15.49	16.87	18.68	1.00	0.93	0.83	0.80	0.57	1.00	1.00	0.88	0.85	0.60	1.00	1.00	0.91	0.89	0.62	1.00	1.00	0.95	0.92	0.64						

PHR524 EXTENDED COOLING PERFORMANCE – HIGH COOL

CFM		CONDENSER ENTERING AIR TEMPERATURES deg F, Dry Bulb																																																	
		75 (23.8°C)						85 (29.4°C)						95 (35°C)						105 (40.5°C)						115 (46.1°C)																									
		57	62	63††	67	72	72	57	62	63††	67	72	72	57	62	63††	67	72	72	57	62	63††	67	72	72	57	62	63††	67	72	72																				
700	MBH†	21.49	22.16	22.52	24.17	26.41	20.88	21.34	21.70	23.27	25.43	20.17	20.42	20.76	22.26	24.35	19.34	19.39	19.72	21.16	23.16	18.35	18.38	18.47	19.94	21.88	1.00	0.91	0.73	0.71	0.52	1.00	0.93	0.75	0.72	0.53	1.00	0.96	0.76	0.74	0.54	1.00	1.00	0.78	0.76	0.55	1.00	1.00	0.80	0.78	0.56
	S/T‡	6.61	6.64	6.66	6.73	6.82	7.31	7.33	7.35	7.42	7.52	8.10	8.11	8.13	8.21	8.32	9.02	9.02	9.03	9.13	9.25	10.13	10.13	10.13	10.13	10.23	10.36	10.36	10.36	10.36	10.36																				
	AMPS*	287	288	289	294	300	331	332	333	339	345	379	380	381	387	394	432	432	433	440	448	490	490	490	491	497	506	506	506	506	506																				
	HI PR	125	129	131	140	151	130	132	134	143	155	134	136	138	147	159	139	140	141	150	162	144	144	144	144	154	166	166	166	166	166																				
	LO PR	22.87	23.05	23.32	25.01	27.31	22.18	22.21	22.40	24.02	26.24	21.38	21.42	21.40	22.93	25.06	20.49	20.52	20.26	21.73	23.79	19.46	19.48	18.97	20.43	22.43	1.00	0.97	0.78	0.75	0.55	1.00	1.00	0.80	0.78	0.58	1.00	1.00	0.84	0.82	0.58	1.00	1.00	0.87	0.85	0.60					
855	S/T‡	6.75	6.76	6.77	6.84	6.93	7.45	7.45	7.46	7.53	7.63	8.24	8.24	8.24	8.32	8.42	9.17	9.17	9.15	9.24	9.36	10.28	10.28	10.28	10.24	10.34	10.46	10.46	10.46	10.46	10.46																				
	AMPS*	290	291	292	296	302	335	335	335	341	347	384	384	383	389	397	437	437	436	442	450	495	495	495	493	499	508	508	508	508	508																				
	HI PR	134	134	135	145	156	138	138	139	148	160	142	142	142	151	163	147	147	145	155	167	152	152	152	148	158	171	171	171	171	171																				
	LO PR	23.27	23.63	23.53	25.24	27.55	22.55	22.58	22.59	24.22	26.45	21.73	21.76	21.56	23.11	25.25	20.81	20.84	20.41	21.90	23.94	19.76	19.79	19.10	20.57	22.57	1.00	0.94	0.79	0.77	0.56	1.00	1.00	0.86	0.84	0.59	1.00	1.00	0.89	0.87	0.61										
	S/T‡	6.80	6.81	6.81	6.88	6.97	7.49	7.49	7.49	7.57	7.66	8.29	8.29	8.27	8.35	8.46	9.21	9.22	9.18	9.28	9.39	10.32	10.32	10.28	10.37	10.50	10.50	10.50	10.50	10.50	10.50																				
AMPS*	291	292	292	297	303	336	336	336	341	348	385	385	384	390	397	438	438	436	443	451	497	497	497	494	509	509	509	509	509	509																					
HI PR	136	138	137	146	158	140	140	140	149	161	145	145	143	152	165	149	149	146	156	168	154	154	154	149	159	172	172	172	172	172																					
LO PR	22.87	23.05	23.32	25.01	27.31	22.18	22.21	22.40	24.02	26.24	21.38	21.42	21.40	22.93	25.06	20.49	20.52	20.26	21.73	23.79	19.46	19.48	18.97	20.43	22.43	1.00	0.97	0.78	0.75	0.55	1.00	1.00	0.80	0.78	0.58	1.00	1.00	0.87	0.85	0.60											

See Legend and Notes on Page 13.

PHR530 EXTENDED COOLING PERFORMANCE – LOW COOL

CFM		CONDENSER ENTERING AIR TEMPERATURES deg F, Dry Bulb																									
		75 (23.8°C)					85 (29.4°C)					95 (35°C)					105 (40.5°C)					115 (46.1°C)					
		57	62	63††	67	72	57	62	63††	67	72	57	62	63††	67	72	57	62	63††	67	72	57	62	63††	67	72	
	MBh†	22.68	23.35	23.75	25.55	28.05	22.01	22.42	22.85	24.57	26.99	21.21	21.41	21.82	23.50	25.83	20.22	20.22	20.29	20.56	22.28	24.56	19.08	19.11	19.12	20.83	23.12
	S/T‡	1.00	0.93	0.74	0.72	0.53	1.00	0.95	0.76	0.73	0.53	1.00	0.98	0.77	0.75	0.54	1.00	0.99	0.79	0.76	0.55	0.55	1.00	1.00	0.82	0.79	0.56
655	AMPS*	6.11	6.09	6.09	6.05	6.02	6.83	6.82	6.81	6.79	6.76	7.65	7.65	7.64	7.62	7.59	8.59	8.59	8.59	8.58	8.55	8.52	9.67	9.67	9.67	9.67	9.58
	HI PR	260	261	262	265	268	301	302	303	306	310	347	347	348	352	356	397	397	397	397	402	407	452	452	452	452	462
	LO PR	128	131	133	142	153	133	135	137	145	157	137	138	140	149	161	141	142	143	153	165	165	146	146	146	146	169
	MBh†	23.95	24.15	24.46	26.31	28.86	23.20	23.24	23.47	25.25	27.73	22.35	22.39	22.36	24.08	26.50	21.33	21.36	21.36	21.07	22.78	25.14	20.14	20.17	20.17	19.58	21.29
	S/T‡	1.00	0.98	0.78	0.76	0.55	1.00	1.00	0.80	0.78	0.56	1.00	1.00	0.82	0.80	0.57	1.00	1.00	0.85	0.82	0.58	0.58	1.00	1.00	0.88	0.85	0.59
775	AMPS*	6.19	6.19	6.18	6.15	6.11	6.91	6.91	6.91	6.88	6.95	7.74	7.74	7.74	7.71	7.69	8.68	8.68	8.68	8.68	8.65	8.62	9.75	9.75	9.75	9.76	9.68
	HI PR	262	262	263	266	270	304	304	304	307	312	349	349	349	353	358	400	400	400	399	403	408	455	455	455	453	458
	LO PR	135	136	137	146	158	139	140	140	150	161	144	144	144	153	165	149	149	147	156	169	169	153	153	149	160	173
	MBh†	24.54	25.08	24.76	26.64	29.22	23.76	23.80	23.75	25.54	28.04	22.87	22.91	22.60	24.34	26.77	21.83	21.86	21.86	21.28	23.01	25.38	20.61	20.64	19.77	21.48	23.82
	S/T‡	1.00	0.95	0.81	0.78	0.56	1.00	1.00	0.83	0.80	0.57	1.00	1.00	0.85	0.82	0.58	1.00	1.00	0.88	0.85	0.60	0.60	1.00	1.00	0.91	0.88	0.61
840	AMPS*	6.23	6.22	6.23	6.20	6.17	6.96	6.96	6.96	6.94	6.91	7.79	7.79	7.79	7.77	7.74	8.73	8.73	8.73	8.74	8.71	8.68	9.79	9.79	9.79	9.82	9.73
	HI PR	263	264	263	266	270	305	305	305	308	312	351	351	350	354	358	401	401	401	399	404	409	456	456	454	458	464
	LO PR	138	141	139	148	160	143	143	142	151	163	147	147	145	155	167	152	152	148	148	158	171	156	156	151	161	174

PHR530 EXTENDED COOLING PERFORMANCE – HIGH COOL

CFM		CONDENSER ENTERING AIR TEMPERATURES deg F, Dry Bulb																								
		75 (23.8°C)					85 (29.4°C)					95 (35°C)					105 (40.5°C)					115 (46.1°C)				
		57	62	63††	67	72	57	62	63††	67	72	57	62	63††	67	72	57	62	63††	67	72	57	62	63††	67	72
	MBh†	27.21	28.23	28.71	30.91	33.94	26.37	27.09	27.58	29.69	32.62	25.44	25.89	26.35	28.37	31.20	24.37	24.58	24.99	26.94	29.67	23.17	23.21	23.47	25.35	27.97
	S/T‡	1.00	0.90	0.72	0.70	0.52	1.00	0.92	0.74	0.71	0.52	1.00	0.95	0.75	0.73	0.53	1.00	0.97	0.77	0.74	0.54	1.00	1.00	0.79	0.77	0.55
875	AMPS*	8.28	8.33	8.35	8.47	8.64	9.14	9.18	9.20	9.32	9.50	10.17	10.20	10.22	10.35	10.53	11.37	11.38	11.40	11.53	11.72	12.71	12.71	12.71	12.73	12.86
	HI PR	276	278	279	283	289	319	321	322	326	332	367	368	369	374	380	419	419	420	425	432	476	476	476	476	482
	LO PR	123	127	129	138	150	127	130	132	141	153	131	133	135	144	156	135	136	138	147	159	140	140	141	141	163
	MBh†	28.45	29.02	29.44	31.69	34.81	27.55	27.83	28.24	30.39	33.40	26.54	26.60	26.93	29.00	31.90	25.40	25.44	25.49	27.48	30.27	24.13	24.16	23.90	25.81	28.50
	S/T‡	1.00	0.94	0.75	0.73	0.53	1.00	0.97	0.77	0.74	0.54	1.00	1.00	0.79	0.76	0.55	1.00	1.00	0.81	0.78	0.56	1.00	1.00	0.83	0.81	0.57
1000	AMPS*	8.46	8.49	8.50	8.63	8.82	9.32	9.33	9.35	9.48	9.67	10.36	10.36	10.37	10.51	10.70	11.55	11.56	11.56	11.69	11.88	12.90	12.90	12.88	13.01	13.21
	HI PR	279	280	280	285	290	322	322	323	328	334	369	370	370	375	382	422	422	422	427	434	479	479	478	484	491
	LO PR	129	131	132	141	153	132	134	135	144	156	137	137	138	147	160	141	141	141	150	163	145	145	143	153	166
	MBh†	29.54	29.72	30.03	32.34	35.47	28.56	28.61	28.76	30.95	33.98	27.48	27.52	27.39	29.49	32.41	26.27	26.31	25.88	27.91	30.72	24.93	24.96	24.24	26.16	28.87
	S/T‡	1.00	0.98	0.78	0.76	0.55	1.00	1.00	0.80	0.78	0.56	1.00	1.00	0.82	0.80	0.57	1.00	1.00	0.85	0.82	0.58	1.00	1.00	0.88	0.85	0.60
1125	AMPS*	8.63	8.64	8.65	8.79	8.98	9.49	9.50	9.50	9.63	9.83	10.53	10.54	10.52	10.66	10.86	11.73	11.73	11.73	11.70	11.84	12.04	13.07	13.08	13.02	13.16
	HI PR	281	281	282	286	292	324	324	324	329	335	372	372	371	377	383	424	424	423	428	435	481	481	479	485	492
	LO PR	134	134	135	144	156	137	137	138	147	159	141	141	140	150	162	145	146	143	153	165	150	150	146	156	169

See Legend and Notes on Page 13.

PHR536 EXTENDED COOLING PERFORMANCE – LOW COOL

CFM		CONDENSER ENTERING AIR TEMPERATURES deg F, Dry Bulb																																																	
		75 (23.8°C)						85 (29.4°C)						95 (35°C)						105 (40.5°C)						115 (46.1°C)																									
		57	62	63††	67	72	72	57	62	63††	67	72	72	57	62	63††	67	72	72	57	62	63††	67	72	72	57	62	63††	67	72	72																				
785	MBH†	24.53	25.14	25.47	27.50	30.11	23.23	23.61	23.90	25.80	28.26	21.88	22.06	22.29	24.05	26.37	20.46	20.49	20.59	22.22	24.39	18.94	18.98	18.79	20.30	22.32	1.00	0.93	0.74	0.72	0.53	1.00	0.95	0.75	0.73	0.53	1.00	0.96	0.77	0.74	0.54	1.00	1.00	0.78	0.76	0.54	1.00	1.00	0.81	0.78	0.54
	S/T‡	6.86	6.83	6.82	6.73	6.62	7.61	7.60	7.59	7.50	7.39	8.44	8.47	8.43	8.34	8.24	9.36	9.36	9.36	9.28	9.18	10.39	10.39	10.40	10.32	10.23	337	337	337	338	341	386	386	386	389	393	439	439	439	442	446	142	142	142	141	150	142	142	141	150	161
	AMPS*	253	253	254	256	259	293	293	294	296	300	337	337	338	341	344	386	386	386	389	393	439	439	439	442	446	142	127	128	138	149	132	133	134	143	155	137	137	137	146	158	142	142	142	141	150	142	142	141	150	161
	HI PR	124	127	128	138	149	128	130	131	140	152	132	133	134	143	155	137	137	137	146	158	142	142	142	141	150	142	142	142	141	150	142	142	142	141	150	142	142	142	141	150	142	142	142	141	150					
	LO PR	25.61	25.85	26.08	28.14	30.81	24.22	24.29	24.44	26.37	28.88	22.78	22.82	22.75	24.54	26.90	21.26	21.30	20.98	22.65	24.84	19.66	19.69	19.12	20.65	22.69	1.00	0.97	0.78	0.75	0.55	1.00	1.00	0.80	0.78	0.56	1.00	1.00	0.82	0.80	0.56	1.00	1.00	0.85	0.82	0.58					
900	MBH†	6.92	6.91	6.91	6.81	6.70	7.68	7.68	7.68	7.58	7.48	8.51	8.51	8.51	8.43	8.32	9.43	9.43	9.43	9.36	9.27	10.46	10.46	10.49	10.41	10.32	339	339	339	339	341	388	388	387	390	394	441	441	441	440	443	441	441	440	443	447					
	S/T‡	130	131	132	141	152	134	134	134	144	155	138	138	137	146	158	142	142	140	149	161	147	147	147	143	153	164	26.49	26.53	26.53	28.64	31.34	23.51	23.54	23.09	24.92	27.29	21.91	21.95	21.28	22.96	25.17	20.23	20.26	19.38	20.93	22.96				
	AMPS*	6.99	6.99	7.00	6.90	6.79	7.75	7.75	7.76	7.67	7.56	8.58	8.58	8.60	8.52	8.41	9.50	9.50	9.50	9.45	9.35	10.53	10.53	10.58	10.50	10.41	340	340	340	339	342	389	389	388	391	394	442	442	442	440	444	442	442	440	444	447					
	HI PR	134	135	134	144	155	138	138	137	146	158	142	142	139	149	161	146	146	146	142	152	164	151	151	151	146	155	167	1.00	1.00	0.81	0.78	0.56	1.00	1.00	0.86	0.84	0.58	1.00	1.00	0.89	0.86	0.60								
	LO PR	134	135	134	144	155	138	138	137	146	158	142	142	139	149	161	146	146	146	142	152	164	151	151	151	146	155	167	1.00	1.00	0.81	0.78	0.56	1.00	1.00	0.86	0.84	0.58	1.00	1.00	0.89	0.86	0.60								

PHR536 EXTENDED COOLING PERFORMANCE – HIGH COOL

CFM		CONDENSER ENTERING AIR TEMPERATURES deg F, Dry Bulb																																																		
		75 (23.8°C)						85 (29.4°C)						95 (35°C)						105 (40.5°C)						115 (46.1°C)																										
		57	62	63††	67	72	72	57	62	63††	67	72	72	57	62	63††	67	72	72	57	62	63††	67	72	72	57	62	63††	67	72	72																					
1050	MBH†	29.99	31.04	31.47	33.96	37.19	30.02	30.82	31.24	33.70	36.92	29.88	30.42	30.80	33.23	36.41	29.55	29.82	30.14	32.52	35.63	28.99	29.04	29.21	31.51	34.55	1.00	0.91	0.73	0.71	0.53	1.00	0.93	0.75	0.72	0.54	1.00	0.95	0.76	0.74	0.54	1.00	0.98	0.78	0.76	0.55	1.00	1.00	0.81	0.78	0.56	
	S/T‡	10.01	10.05	10.07	10.17	10.30	10.97	11.00	11.02	11.12	11.26	12.02	12.05	12.06	12.16	12.30	13.21	13.22	13.23	13.33	13.46	14.56	14.56	14.56	14.65	14.78	267	269	269	273	277	309	310	311	314	319	355	355	356	360	365	405	405	406	410	415	459	460	460	464	470	
	AMPS*	118	122	123	133	144	122	125	126	135	146	125	127	128	138	149	129	130	131	140	152	134	134	134	143	143	155	31.38	31.94	32.29	34.84	38.14	31.36	31.70	32.01	34.53	37.80	30.79	30.84	30.79	33.22	36.38	30.15	30.20	29.79	32.13	35.21					
	HI PR	10.19	10.22	10.23	10.33	10.48	11.15	11.16	11.18	11.28	11.43	12.20	12.21	12.21	12.32	12.47	13.38	13.38	13.38	13.48	13.63	14.72	14.73	14.71	14.81	14.94	269	270	270	274	279	311	311	312	316	321	357	357	357	361	367	407	407	407	411	417	462	462	461	466	471	
	LO PR	124	126	127	136	148	127	128	129	139	150	131	131	132	141	152	135	135	134	144	155	139	139	137	146	158	158	32.57	32.83	32.96	35.54	38.89	32.52	32.58	32.62	35.19	38.51	31.84	31.89	31.32	33.77	36.96	31.13	31.18	30.26	32.63	35.73					
1350	MBH†	1.00	0.97	0.79	0.77	0.56	1.00	1.00	0.81	0.78	0.57	1.00	1.00	0.83	0.80	0.58	1.00	1.00	0.85	0.83	0.59	1.00	1.00	0.88	0.86	0.60	10.37	10.38	10.38	10.49	10.65	11.33	11.33	11.33	11.44	11.59	12.37	12.38	12.36	12.47	12.63	13.55	13.55	13.53	13.63	13.78	14.89	14.89	14.85	14.95	15.09	
	S/T‡	271	271	271	275	280	313	313	313	317	322	359	359	358	363	368	409	409	408	413	418	464	464	462	467	472	472	271	271	271	275	280	313	313	313	317	322	359	359	358	363	368	409	409	408	413	418	464	464	462	467	472
	AMPS*	129	130	130	139	151	132	132	132	142	153	135	136	134	144	155	139	139	137	146	158	143	143	143	139	149	160	10.37	10.38	10.38	10.49	10.65	11.33	11.33	11.33	11.44	11.59	12.37	12.38	12.36	12.47	12.63	13.55	13.55	13.53	13.63	13.78	14.89	14.89	14.85	14.95	15.09
	HI PR	129	130	130	139	151	132	132	132	142	153	135	136	134	144	155	139	139	137	146	158	143	143	143	139	149	160	10.37	10.38	10.38	10.49	10.65	11.33	11.33	11.33	11.44	11.59	12.37	12.38	12.36	12.47	12.63	13.55	13.55	13.53	13.63	13.78	14.89	14.89	14.85	14.95	15.09
	LO PR	129	130	130	139	151	132	132	132	142	153	135	136	134	144	155	139	139	137	146	158	143	143	143	139	149	160	10.37	10.38	10.38	10.49	10.65	11.33	11.33	11.33	11.44	11.59	12.37	12.38	12.36	12.47	12.63	13.55	13.55	13.53	13.63	13.78	14.89	14.89	14.85	14.95	15.09

See Legend and Notes on Page 13.

PHR542 EXTENDED COOLING PERFORMANCE – LOW COOL

		CONDENSER ENTERING AIR TEMPERATURES deg F, Dry Bulb																			
		75 (23.8°C)				85 (29.4°C)				95 (35°C)				105 (40.5°C)				115 (46.1°C)			
		57	62	63††	67	72	77	82	87	92	97	102	107	112	117	122	127	132	137	142	147
CFM	MBH†	29.52	30.35	30.73	33.18	36.31	29.22	29.81	30.17	32.56	35.62	28.70	29.02	29.34	31.66	34.66	27.93	28.00	28.23	30.47	33.38
	S/T‡	1.00	0.92	0.74	0.71	0.53	1.00	0.93	0.74	0.71	0.53	1.00	0.94	0.75	0.72	0.53	1.00	1.00	0.77	0.74	0.53
	AMPS*	8.24	8.21	8.20	8.10	7.97	8.73	8.71	8.70	8.59	8.46	9.28	9.26	9.25	9.14	9.00	9.86	9.86	9.85	9.73	9.59
	HI PR	253	254	255	257	260	294	295	295	298	301	338	339	339	342	346	387	387	388	391	395
	LO PR	122	125	126	135	145	126	128	129	138	148	130	131	132	141	151	135	135	135	144	155
915	MBH†	30.80	31.19	31.46	33.99	37.17	30.44	30.63	30.84	33.28	36.41	29.85	29.90	29.94	32.32	35.37	29.01	29.06	28.76	31.03	34.01
	S/T‡	1.00	0.96	0.77	0.74	0.54	1.00	0.97	0.77	0.75	0.54	1.00	1.00	0.79	0.76	0.54	1.00	1.00	0.80	0.78	0.55
	AMPS*	8.34	8.33	8.32	8.22	8.09	8.83	8.82	8.82	8.71	8.57	9.36	9.36	9.36	9.25	9.11	9.94	9.93	9.96	9.83	9.68
	HI PR	255	255	256	258	262	296	296	296	299	302	340	340	340	343	347	389	389	389	392	396
	LO PR	128	129	130	138	149	131	132	132	141	152	135	135	135	144	155	140	140	138	147	158
1050	MBH†	31.85	31.93	32.02	34.59	37.82	31.44	31.49	31.34	33.84	37.00	30.79	30.84	30.40	32.80	35.90	29.88	29.92	29.15	31.47	34.47
	S/T‡	1.00	1.00	0.79	0.77	0.55	1.00	1.00	0.80	0.78	0.55	1.00	1.00	0.82	0.79	0.56	1.00	1.00	0.84	0.81	0.57
	AMPS*	8.45	8.45	8.45	8.34	8.21	8.93	8.92	8.94	8.82	8.69	9.45	9.45	9.48	9.36	9.21	10.02	10.01	10.06	9.94	9.78
	HI PR	256	256	256	259	262	297	297	297	300	303	342	342	341	344	348	390	390	389	393	396
	LO PR	132	132	132	141	152	135	136	135	144	154	139	140	137	147	157	144	144	141	150	160
1180	MBH†	10.40	10.40	10.40	10.40	10.40	10.40	10.40	10.40	10.40	10.40	10.40	10.40	10.40	10.40	10.40	10.40	10.40	10.40	10.40	10.40
	S/T‡	10.40	10.40	10.40	10.40	10.40	10.40	10.40	10.40	10.40	10.40	10.40	10.40	10.40	10.40	10.40	10.40	10.40	10.40	10.40	10.40
	AMPS*	10.40	10.40	10.40	10.40	10.40	10.40	10.40	10.40	10.40	10.40	10.40	10.40	10.40	10.40	10.40	10.40	10.40	10.40	10.40	10.40
	HI PR	10.40	10.40	10.40	10.40	10.40	10.40	10.40	10.40	10.40	10.40	10.40	10.40	10.40	10.40	10.40	10.40	10.40	10.40	10.40	10.40
	LO PR	10.40	10.40	10.40	10.40	10.40	10.40	10.40	10.40	10.40	10.40	10.40	10.40	10.40	10.40	10.40	10.40	10.40	10.40	10.40	10.40

PHR542 EXTENDED COOLING PERFORMANCE – HIGH COOL

		CONDENSER ENTERING AIR TEMPERATURES deg F, Dry Bulb																			
		75 (23.8°C)				85 (29.4°C)				95 (35°C)				105 (40.5°C)				115 (46.1°C)			
		57	62	63††	67	72	77	82	87	92	97	102	107	112	117	122	127	132	137	142	147
CFM	MBH†	38.98	40.38	40.90	44.01	47.98	38.14	39.21	39.69	42.69	46.53	37.10	37.82	38.26	41.12	44.80	35.84	36.23	36.56	39.28	42.80
	S/T‡	1.00	0.85	0.69	0.66	0.50	1.00	0.88	0.71	0.68	0.51	1.00	0.91	0.73	0.71	0.52	1.00	0.95	0.76	0.73	0.54
	AMPS*	12.94	12.97	12.97	13.03	13.10	13.87	13.89	13.90	13.97	14.06	14.91	14.93	14.94	15.01	15.11	16.07	16.08	16.09	16.17	16.27
	HI PR	269	271	271	275	279	311	312	313	317	322	357	358	358	362	367	407	407	408	412	417
	LO PR	116	120	121	130	141	120	123	124	133	144	124	126	127	136	147	128	129	130	139	150
1225	MBH†	40.69	41.49	41.91	45.10	49.14	39.76	40.27	40.62	43.68	47.58	38.61	38.84	39.08	42.00	45.74	37.22	37.29	37.28	40.04	43.62
	S/T‡	1.00	0.89	0.71	0.69	0.51	1.00	0.92	0.73	0.71	0.52	1.00	0.95	0.76	0.74	0.54	1.00	1.00	0.80	0.77	0.56
	AMPS*	13.16	13.17	13.18	13.24	13.31	14.08	14.10	14.10	14.17	14.26	15.13	15.14	15.14	15.22	15.32	16.28	16.28	16.28	16.37	16.48
	HI PR	271	272	272	276	281	313	314	314	318	323	359	359	359	364	369	409	409	409	413	419
	LO PR	122	124	125	134	145	125	127	127	136	147	129	130	130	139	150	133	133	133	142	153
1400	MBH†	42.16	42.48	42.73	45.97	50.06	41.14	41.22	41.36	44.46	48.41	39.89	39.95	39.73	42.69	46.48	38.39	38.45	37.84	40.64	44.26
	S/T‡	1.00	0.92	0.74	0.71	0.52	1.00	1.00	0.76	0.74	0.54	1.00	1.00	0.79	0.77	0.55	1.00	1.00	0.83	0.81	0.57
	AMPS*	13.37	13.38	13.38	13.44	13.52	14.30	14.30	14.30	14.38	14.47	15.34	15.34	15.34	15.42	15.52	16.49	16.49	16.47	16.56	16.67
	HI PR	273	273	274	277	282	315	315	315	319	324	361	361	361	365	370	411	411	410	415	420
	LO PR	127	127	128	137	148	130	130	130	139	150	134	134	134	142	153	138	138	138	145	156
1575	MBH†	46.66	46.66	46.66	46.66	46.66	46.66	46.66	46.66	46.66	46.66	46.66	46.66	46.66	46.66	46.66	46.66	46.66	46.66	46.66	46.66
	S/T‡	46.66	46.66	46.66	46.66	46.66	46.66	46.66	46.66	46.66	46.66	46.66	46.66	46.66	46.66	46.66	46.66	46.66	46.66	46.66	46.66
	AMPS*	46.66	46.66	46.66	46.66	46.66	46.66	46.66	46.66	46.66	46.66	46.66	46.66	46.66	46.66	46.66	46.66	46.66	46.66	46.66	46.66
	HI PR	46.66	46.66	46.66	46.66	46.66	46.66	46.66	46.66	46.66	46.66	46.66	46.66	46.66	46.66	46.66	46.66	46.66	46.66	46.66	46.66
	LO PR	46.66	46.66	46.66	46.66	46.66	46.66	46.66	46.66	46.66	46.66	46.66	46.66	46.66	46.66	46.66	46.66	46.66	46.66	46.66	46.66

See Legend and Notes on Page 13.

PHR548 EXTENDED COOLING PERFORMANCE – LOW COOL

CFM		CONDENSER ENTERING AIR TEMPERATURES deg F, Dry Bulb																								
		75 (23.8°C)					85 (29.4°C)					95 (35°C)					105 (40.5°C)					115 (46.1°C)				
		57	62	63††	67	72	57	62	63††	67	72	57	62	63††	67	72	57	62	63††	67	72	57	62	63††	67	72
1050	MBH†	33.27	34.14	34.56	37.33	40.83	32.91	33.49	33.88	36.59	40.03	32.31	32.60	32.92	35.55	38.91	31.43	31.48	31.64	34.17	37.44	30.20	30.25	29.96	32.36	35.50
	S/T‡	1.00	0.92	0.74	0.71	0.52	1.00	0.94	0.74	0.72	0.52	1.00	0.95	0.75	0.73	0.53	1.00	1.00	0.77	0.74	0.53	1.00	1.00	0.80	0.77	0.54
	AMPS*	9.27	9.24	9.23	9.13	9.01	9.94	9.92	9.92	9.82	9.71	10.63	10.62	10.61	10.53	10.42	11.33	11.33	11.33	11.25	11.16	12.05	12.05	12.07	12.00	11.91
	HI PR	256	256	257	259	263	296	297	297	300	304	341	342	342	345	349	390	390	391	394	398	444	444	444	447	451
	LO PR	122	125	126	134	145	126	128	128	137	148	130	131	132	140	151	135	135	135	144	155	140	141	139	148	158
1200	MBH†	34.64	35.04	35.33	38.18	41.74	34.21	34.34	34.58	37.34	40.84	33.54	33.59	33.54	36.22	39.64	32.56	32.61	32.17	34.73	38.06	31.21	31.26	30.39	32.82	36.01
	S/T‡	1.00	0.96	0.76	0.74	0.54	1.00	1.00	0.77	0.75	0.54	1.00	1.00	0.79	0.76	0.54	1.00	1.00	0.81	0.78	0.55	1.00	1.00	0.84	0.81	0.56
	AMPS*	9.42	9.41	9.40	9.30	9.17	10.09	10.08	10.08	9.98	9.87	10.77	10.77	10.78	10.69	10.58	11.47	11.46	11.49	11.41	11.31	12.18	12.18	12.22	12.14	12.06
	HI PR	257	258	258	260	264	298	298	298	301	305	343	343	343	346	350	392	392	392	395	399	446	446	444	448	452
	LO PR	127	128	129	138	148	131	131	131	141	151	135	135	134	144	154	140	140	138	147	157	145	145	141	150	161
1310	MBH†	35.51	35.63	35.78	38.66	42.26	35.04	35.10	34.98	37.79	41.32	34.31	34.37	33.90	36.60	40.06	33.27	33.32	32.48	35.06	38.41	31.84	31.88	30.64	33.08	36.28
	S/T‡	1.00	1.00	0.79	0.76	0.55	1.00	1.00	0.80	0.77	0.55	1.00	1.00	0.81	0.79	0.55	1.00	1.00	0.84	0.81	0.56	1.00	1.00	0.87	0.84	0.58
	AMPS*	9.53	9.53	9.53	9.42	9.30	10.20	10.20	10.21	10.11	10.00	10.88	10.87	10.90	10.81	10.70	11.57	11.57	11.60	11.52	11.43	12.28	12.28	12.33	12.25	12.16
	HI PR	258	258	258	261	264	299	299	299	302	306	344	344	344	347	351	393	393	392	395	399	447	447	445	448	452
	LO PR	130	131	131	140	150	134	134	133	143	153	138	138	136	145	156	143	143	139	149	159	148	148	143	152	163

PHR548 EXTENDED COOLING PERFORMANCE – HIGH COOL

CFM		CONDENSER ENTERING AIR TEMPERATURES deg F, Dry Bulb																								
		75 (23.8°C)					85 (29.4°C)					95 (35°C)					105 (40.5°C)					115 (46.1°C)				
		57	62	63††	67	72	57	62	63††	67	72	57	62	63††	67	72	57	62	63††	67	72	57	62	63††	67	72
1400	MBH†	47.11	48.61	49.20	53.05	57.95	44.71	45.76	46.30	49.87	54.46	42.15	42.79	43.23	46.54	50.80	39.43	39.69	40.00	43.04	46.99	36.54	36.59	36.61	39.37	42.99
	S/T‡	1.00	0.89	0.72	0.69	0.51	1.00	0.91	0.73	0.71	0.52	1.00	0.94	0.75	0.72	0.53	1.00	0.97	0.77	0.75	0.54	1.00	1.00	0.80	0.78	0.56
	AMPS*	12.92	12.96	12.97	13.08	13.20	14.72	14.75	14.76	14.87	15.00	16.80	16.82	16.83	16.94	17.08	19.17	19.18	19.19	19.30	19.44	21.86	21.86	21.87	21.97	22.10
	HI PR	271	272	273	277	281	313	314	315	319	324	359	360	361	365	371	410	410	411	415	421	465	465	465	469	475
	LO PR	116	120	121	130	140	120	122	123	132	143	124	125	126	135	146	128	129	129	138	149	133	133	132	141	152
1600	MBH†	49.16	49.94	50.40	54.35	59.33	46.58	47.00	47.95	51.01	55.66	43.82	43.92	44.12	47.50	51.82	40.91	40.98	40.73	43.83	47.83	37.82	37.87	37.20	40.01	43.65
	S/T‡	1.00	0.93	0.74	0.72	0.53	1.00	0.95	0.76	0.74	0.54	1.00	1.00	0.78	0.76	0.55	1.00	1.00	0.81	0.79	0.56	1.00	1.00	0.84	0.82	0.58
	AMPS*	13.19	13.22	13.23	13.34	13.46	15.00	15.02	15.02	15.13	15.27	17.09	17.09	17.10	17.21	17.34	19.47	19.47	19.46	19.57	19.70	22.16	22.16	22.14	22.24	22.37
	HI PR	273	274	274	278	283	315	316	316	321	326	362	362	362	367	372	412	413	412	417	422	467	467	466	471	477
	LO PR	122	124	124	133	144	125	126	127	136	146	129	129	129	138	149	133	133	132	141	152	138	138	135	144	155
1800	MBH†	50.93	51.07	51.36	55.37	60.42	48.17	48.26	48.17	51.89	56.58	45.25	45.32	44.83	48.24	52.59	42.16	42.22	41.31	44.44	48.47	38.88	38.94	37.65	40.49	44.14
	S/T‡	1.00	1.00	0.77	0.75	0.54	1.00	1.00	0.79	0.77	0.55	1.00	1.00	0.82	0.79	0.56	1.00	1.00	0.85	0.82	0.58	1.00	1.00	0.88	0.86	0.60
	AMPS*	13.47	13.47	13.47	13.58	13.71	15.28	15.28	15.28	15.39	15.52	17.37	17.37	17.36	17.47	17.60	19.76	19.76	19.73	19.83	19.97	22.45	22.45	22.40	22.51	22.63
	HI PR	275	275	275	279	284	318	318	317	322	327	364	364	363	368	374	415	415	413	418	424	469	469	467	472	478
	LO PR	126	127	127	136	147	130	130	129	138	149	133	134	132	141	152	137	138	134	144	154	142	142	137	147	157

See Legend and Notes on Page 13.

PHR560 EXTENDED COOLING PERFORMANCE – LOW COOL																											
CONDENSER ENTERING AIR TEMPERATURES deg F, Dry Bulb																											
75 (23.8°C)																											
85 (29.4°C)																											
95 (35°C)																											
105 (40.5°C)																											
115 (46.1°C)																											
CFM	57	62	63††	67	72	72	72	63††	67	72	72	72															
1200	MBH†	40.08	41.22	41.84	45.19	49.64	39.27	40.03	40.60	43.84	48.16	38.24	38.63	39.11	42.22	46.40	36.91	36.98	37.28	40.24	44.26	35.20	35.25	35.01	37.81	41.65	
	S/T‡	1.00	0.92	0.73	0.71	0.52	1.00	0.92	0.74	0.71	0.52	1.00	0.93	0.74	0.71	0.52	1.00	1.00	0.75	0.72	0.52	1.00	1.00	0.76	0.74	0.53	
	AMPS*	10.87	10.83	10.81	10.69	10.53	12.78	12.76	12.74	12.62	12.47	14.99	14.97	14.96	14.84	14.69	17.53	17.53	17.52	17.41	17.27	20.48	20.47	20.49	20.38	20.24	
	HI PR	260	261	261	265	269	301	301	302	305	310	346	346	346	350	355	395	395	395	399	404	448	448	448	448	452	457
	LO PR	125	128	129	138	150	128	131	132	141	153	133	134	135	144	156	137	138	138	147	159	143	143	143	142	151	163
1400	MBH†	42.14	42.56	43.00	46.42	50.98	41.21	41.32	41.64	44.95	49.37	40.05	40.16	40.03	43.19	47.46	38.57	38.63	38.07	41.08	45.17	36.69	36.74	35.67	38.50	42.38	
	S/T‡	1.00	0.96	0.77	0.74	0.54	1.00	1.00	0.77	0.75	0.54	1.00	1.00	0.78	0.76	0.54	1.00	1.00	0.79	0.77	0.54	1.00	1.00	0.81	0.79	0.55	
	AMPS*	10.99	10.97	10.97	10.83	10.68	12.91	12.91	12.91	12.78	12.62	15.13	15.12	15.14	15.01	14.86	17.68	17.68	17.71	17.59	17.45	20.64	20.64	20.69	20.57	20.43	
	HI PR	262	262	263	266	270	303	303	303	307	311	348	348	348	351	356	397	397	397	396	400	405	451	451	449	453	458
	LO PR	131	132	133	142	154	135	135	135	145	157	139	139	138	148	159	143	144	141	151	163	149	149	149	145	154	166
1545	MBH†	43.42	43.50	43.65	47.13	51.75	42.41	42.48	42.24	45.58	50.05	41.16	41.22	40.55	43.75	48.06	39.58	39.64	38.52	41.55	45.66	37.59	37.64	36.04	38.90	42.77	
	S/T‡	1.00	1.00	0.80	0.77	0.56	1.00	1.00	0.80	0.78	0.55	1.00	1.00	0.81	0.78	0.56	1.00	1.00	0.82	0.80	0.56	1.00	1.00	0.84	0.82	0.57	
	AMPS*	11.08	11.08	11.08	10.95	10.79	13.02	13.01	13.03	12.90	12.75	15.24	15.23	15.27	15.14	14.99	17.80	17.80	17.85	17.73	17.58	20.76	20.76	20.83	20.71	20.58	
	HI PR	263	263	263	267	271	304	304	304	308	312	349	349	348	352	357	398	399	397	401	406	452	452	450	454	459	
	LO PR	135	135	135	145	156	139	139	138	147	159	143	143	140	150	162	147	147	143	153	165	152	152	147	147	156	168

PHR560 EXTENDED COOLING PERFORMANCE – HIGH COOL																										
CONDENSER ENTERING AIR TEMPERATURES deg F, Dry Bulb																										
75 (23.8°C)																										
85 (29.4°C)																										
95 (35°C)																										
105 (40.5°C)																										
115 (46.1°C)																										
CFM	57	62	63††	67	72	72	72	63††	67	72	72	72														
1750	MBH†	56.24	57.69	58.47	62.98	69.04	54.20	55.14	55.84	60.12	65.88	51.93	52.40	53.00	57.00	62.44	49.38	49.47	49.79	53.55	58.65	46.49	46.55	46.25	49.70	54.42
	S/T‡	1.00	0.88	0.70	0.68	0.50	1.00	0.91	0.72	0.70	0.51	1.00	0.94	0.75	0.73	0.53	1.00	1.00	0.78	0.76	0.55	1.00	1.00	0.82	0.80	0.57
	AMPS*	17.71	17.75	17.76	17.85	17.93	19.01	19.04	19.05	19.15	19.26	20.50	20.52	20.53	20.65	20.78	22.19	22.19	22.20	22.34	22.50	24.06	24.07	24.05	24.21	24.39
	HI PR	280	281	282	287	293	322	324	324	329	336	369	370	370	375	382	419	420	420	425	432	474	474	474	474	486
	LO PR	124	127	128	138	149	127	129	130	140	152	131	132	133	143	155	135	136	136	145	157	140	140	140	139	148
2000	MBH†	58.56	59.18	59.71	64.29	70.42	56.34	56.54	56.91	61.27	67.12	53.87	53.98	53.86	57.95	63.49	51.12	51.20	50.55	54.34	59.50	47.96	48.04	46.85	50.30	55.04
	S/T‡	1.00	0.91	0.73	0.71	0.51	1.00	1.00	0.76	0.73	0.53	1.00	1.00	0.79	0.77	0.55	1.00	1.00	0.82	0.80	0.57	1.00	1.00	0.87	0.85	0.59
	AMPS*	18.16	18.17	18.18	18.26	18.33	19.45	19.46	19.46	19.56	19.65	20.95	20.95	20.94	21.05	21.18	22.63	22.63	22.60	22.74	22.89	24.50	24.50	24.44	24.60	24.78
	HI PR	283	283	284	288	295	325	326	326	331	337	372	372	372	377	384	422	422	421	427	434	477	477	475	480	487
	LO PR	130	131	132	141	153	133	133	134	143	155	137	137	136	146	158	141	141	139	149	161	145	146	142	151	164
2250	MBH†	60.54	60.65	60.64	65.28	71.51	58.15	58.25	57.73	62.11	68.04	55.50	55.59	54.57	58.68	64.27	52.54	52.62	51.09	54.89	60.09	49.18	49.25	47.29	50.73	55.45
	S/T‡	1.00	1.00	0.76	0.74	0.53	1.00	1.00	0.79	0.77	0.55	1.00	1.00	0.83	0.80	0.57	1.00	1.00	0.86	0.84	0.59	1.00	1.00	0.91	0.89	0.62
	AMPS*	18.59	18.59	18.59	18.66	18.72	19.88	19.88	19.87	19.96	20.05	21.37	21.37	21.34	21.45	21.57	23.05	23.05	23.00	23.13	23.27	24.92	24.92	24.83	24.98	25.15
	HI PR	285	285	285	290	296	328	328	327	332	339	374	374	373	378	385	425	425	423	428	435	479	479	476	482	488
	LO PR	135	135	134	144	156	138	138	136	146	158	142	142	139	149	161	146	146	141	151	163	150	150	144	144	154

LEGEND
† Total capacities are net (I.D blower heat subtracted) system capacities based on 25' line set.
‡ If additional tubing length and/or indoor unit is located above outdoor unit, a slight variation in capacity may occur.
* System amps are total of indoor and outdoor amps
‡ S/T are based on 80 F db entering air at the indoor coil. For sensible capacities at other than 80 F db, deduct 835 Btuh per 1000 cfm of indoor coil air from MBHxS/T for each degree below 80 F, or add 835 Btuh per 1000 cfm of indoor coil air from MBHxS/T for each degree above 80 F
†† At TVA rating indoor condition (75 F db/ 63 F wb), All other indoor air temperatures are at 80 F db

PHR524 EXTENDED HEATING PERFORMANCE – LOW HEAT

CFM		OUTDOOR AMBIENT TEMPERATURE deg F, Dry Bulb																											
		0 (-17.7°C)				10 (-12.2°C)				20 (-6.7°C)				30 (-1.1°C)				40 (-4.4°C)				50 (10°C)				60 (-15.6°C)			
		65	70	75	65	70	75	65	70	75	65	70	75	65	70	75	65	70	75	65	70	75	65	70	75	65	70	75	
525	MBht	4.54	4.52	4.43	6.59	6.52	6.42	8.31	8.15	11.85	11.65	11.42	14.14	13.90	13.65	17.65	17.35	17.05	21.47	21.24	21.01								
	T/R	12.20	12.10	11.80	16.40	16.20	15.90	20.60	20.20	25.80	25.30	24.70	30.80	30.20	29.60	36.10	35.40	34.80	41.50	41.00	40.40								
	AMPS*	4.36	4.63	4.90	4.61	4.88	5.15	4.93	5.17	5.42	5.34	5.57	5.87	6.09	6.33	6.50	6.75	7.00	7.16	7.46	7.75								
	HI PR	203	218	233	217	232	248	237	252	267	282	264	278	270	282	295	289	302	314	305	319	331							
	LO PR	45	45	45	57	57	57	70	70	71	85	85	86	102	103	103	121	122	122	141	142	143							
675	MBht	4.56	4.56	4.50	6.64	6.59	6.50	8.38	8.24	11.90	11.71	11.50	14.21	13.96	13.70	17.60	17.37	17.11	21.49	21.28	20.93								
	T/R	9.90	9.80	9.70	13.30	13.20	13.00	17.00	16.80	20.90	20.50	20.10	25.00	24.50	24.00	29.10	28.70	28.20	33.60	33.20	32.50								
	AMPS*	4.29	4.58	4.85	4.53	4.81	5.08	4.90	5.15	5.38	5.36	5.59	5.82	5.89	6.12	6.43	6.68	7.03	7.20	7.48	7.75								
	HI PR	198	213	228	213	228	243	232	247	262	277	259	272	264	277	283	295	308	299	312	324								
	LO PR	45	45	45	57	57	57	70	70	70	85	85	86	102	103	103	120	121	122	141	142	142							
700	MBht	4.56	4.58	4.52	6.65	6.62	6.52	8.51	8.40	11.92	11.73	11.51	14.22	13.98	13.72	17.58	17.37	17.25	21.47	21.22	20.91								
	T/R	9.20	9.20	9.00	12.40	12.30	12.10	15.90	15.60	19.50	19.10	18.70	23.20	22.80	22.30	27.00	26.60	26.40	31.10	30.70	30.20								
	AMPS*	4.28	4.57	4.84	4.52	4.79	5.06	4.91	5.15	5.39	5.38	5.60	5.83	5.90	6.13	6.44	6.69	7.04	7.21	7.48	7.76								
	HI PR	194	209	224	208	223	239	227	242	257	272	254	267	259	271	284	277	290	302	293	306	318							
	LO PR	45	45	45	56	57	57	70	70	70	85	85	86	102	103	103	120	121	122	140	141	142							

PHR524 EXTENDED HEATING PERFORMANCE – HIGH HEAT

CFM		OUTDOOR AMBIENT TEMPERATURE deg F, Dry Bulb																															
		-10 (-23.3°C)				0 (-17.7°C)				10 (-12.2°C)				20 (-6.7°C)				30 (-1.1°C)				40 (-4.4°C)				50 (10°C)				60 (-15.6°C)			
		65	70	75	65	70	75	65	70	75	65	70	75	65	70	75	65	70	75	65	70	75	65	70	75	65	70	75					
700	MBht	5.87	5.80	5.72	7.69	7.60	7.50	10.57	10.44	13.29	13.10	12.92	16.64	16.42	16.28	20.45	20.26	20.11	25.11	24.84	24.61												
	T/R	12.90	12.80	12.60	15.80	15.60	15.40	19.20	18.90	23.10	22.70	22.30	27.00	26.60	26.20	31.50	31.10	30.70	36.80	36.30	35.80												
	AMPS*	5.19	5.43	5.68	5.55	5.79	6.02	6.07	6.31	6.55	6.25	6.48	6.71	6.49	6.70	6.96	7.30	7.65	8.02	8.33	8.58												
	HI PR	208	223	239	214	228	242	227	240	253	245	257	269	264	276	290	281	294	310	304	316	328											
	LO PR	32	32	32	42	42	42	53	54	54	66	67	67	81	82	97	98	98	113	114	115	132											
855	MBht	5.92	5.87	5.80	7.75	7.66	7.56	10.63	10.50	13.35	13.16	12.99	16.72	16.49	16.33	20.60	20.45	20.30	25.06	24.77	24.53												
	T/R	10.50	10.40	10.20	12.80	12.70	12.50	15.50	15.30	18.60	18.40	18.10	22.20	21.80	21.50	25.90	25.50	25.10	29.50	29.10	28.70												
	AMPS*	5.45	5.45	5.69	5.62	5.84	6.08	6.15	6.38	6.63	6.31	6.54	6.78	6.52	6.77	7.02	7.33	7.62	7.98	8.05	8.38												
	HI PR	204	219	235	210	223	237	223	235	248	240	252	264	259	270	284	275	288	304	298	310	321											
	LO PR	32	32	32	42	42	42	53	54	54	66	67	67	81	82	96	97	98	113	114	115	131											
900	MBht	5.93	5.87	5.80	7.76	7.67	7.58	10.64	10.51	13.37	13.17	12.99	16.94	16.73	16.50	20.80	20.65	20.50	25.65	25.30	25.11												
	T/R	10.20	10.10	9.90	12.40	12.30	12.10	15.00	14.80	18.00	17.80	17.50	21.40	21.10	20.80	25.00	24.80	24.40	29.00	28.50	28.10												
	AMPS*	5.21	5.45	5.69	5.63	5.85	6.10	6.16	6.40	6.64	6.32	6.56	6.80	6.53	6.77	7.02	7.34	7.62	8.00	8.04	8.38												
	HI PR	200	214	230	206	219	233	218	230	243	236	247	259	253	265	278	270	282	298	292	304	315											
	LO PR	32	32	32	42	42	42	53	54	54	66	67	67	81	81	82	96	97	98	113	114	115	131										

See Legend and Notes on Page 19.

PHR536 EXTENDED HEATING PERFORMANCE – LOW HEAT

		OUTDOOR AMBIENT TEMPERATURE deg F, Dry Bulb																							
		-5 (-21.6°C)			0 (-17.7°C)			10 (-12.2°C)			20 (-6.7°C)			30 (-1.1°C)			40 (-4.4°C)			50 (10°C)			60 (-15.6°C)		
		65	70	75	65	70	75	65	70	75	65	70	75	65	70	75	65	70	75	65	70	75	65	70	75
CFM	MBH†	4.15	4.05	0.00	6.33	5.88	5.38	9.00	8.54	8.06	12.07	11.62	11.13	15.61	15.14	14.65	19.82	19.18	18.65	24.39	24.04	23.65	29.08	28.64	28.19
	T/R	6.90	6.70	-75.00	10.30	9.60	8.70	14.00	13.30	12.50	18.10	17.40	16.60	22.50	21.70	21.00	27.40	26.50	25.70	32.50	32.00	31.40	37.40	36.80	36.10
	AMPS*	7.49	7.88	0.00	7.64	8.00	8.36	7.74	8.10	8.47	7.82	8.19	8.57	7.90	8.28	8.67	8.01	8.38	8.78	8.11	8.53	8.98	8.15	8.58	9.04
	HI PR	203	218	-15	214	228	243	227	241	257	241	256	272	257	273	290	277	293	310	298	317	336	319	338	358
	LO PR	34	36	-15	45	45	45	57	57	57	70	71	71	86	86	87	103	103	104	122	122	123	143	143	144
900	MBH†	4.25	4.17	4.29	6.46	6.03	5.53	9.17	8.74	8.25	12.30	11.86	11.38	15.89	15.44	14.94	20.50	19.59	19.03	24.73	24.36	23.99	29.54	29.09	28.63
	T/R	6.20	6.10	6.20	9.20	8.60	7.80	12.50	11.90	11.20	16.10	15.50	14.80	19.90	19.30	18.70	24.80	23.60	22.90	28.80	28.30	27.80	33.20	32.60	32.00
	AMPS*	7.57	7.97	8.39	7.70	8.07	8.43	7.76	8.13	8.51	7.81	8.18	8.57	7.84	8.23	8.62	7.95	8.28	8.68	7.94	8.36	8.80	7.93	8.35	8.79
	HI PR	201	217	234	211	225	240	222	237	253	235	251	267	249	266	283	269	283	300	285	304	323	304	323	342
	LO PR	34	36	40	45	45	45	57	57	57	70	71	71	85	86	86	102	103	103	121	122	122	142	142	143
1010	MBH†	4.35	4.27	4.40	6.60	6.16	5.66	9.34	8.90	8.41	12.50	12.06	11.58	16.13	15.68	15.19	20.74	19.96	19.33	25.01	24.64	24.27	29.90	29.44	28.98
	T/R	5.60	5.50	5.70	8.40	7.80	7.10	11.30	10.80	10.20	14.50	14.00	13.40	18.00	17.50	16.90	22.30	21.40	20.70	25.90	25.50	25.10	29.90	29.40	28.90
	AMPS*	7.66	8.06	8.48	7.77	8.15	8.52	7.80	8.18	8.57	7.82	8.20	8.59	7.83	8.21	8.61	7.89	8.24	8.63	7.84	8.26	8.69	7.79	8.21	8.65
	HI PR	200	216	233	209	223	238	219	234	250	231	246	263	244	260	277	261	276	293	276	294	313	293	311	331
	LO PR	34	36	40	45	45	45	57	57	57	70	70	71	85	86	86	102	103	103	121	121	122	142	142	143

PHR536 EXTENDED HEATING PERFORMANCE – HIGH HEAT

		OUTDOOR AMBIENT TEMPERATURE deg F, Dry Bulb																							
		-10 (-23.3°C)			0 (-17.7°C)			10 (-12.2°C)			20 (-6.7°C)			30 (-1.1°C)			40 (-4.4°C)			50 (10°C)			60 (-15.6°C)		
		65	70	75	65	70	75	65	70	75	65	70	75	65	70	75	65	70	75	65	70	75	65	70	75
CFM	MBH†	9.02	8.61	8.18	12.22	11.81	11.37	15.90	15.47	15.02	20.56	19.83	19.22	24.91	24.58	24.24	29.96	29.54	29.12	35.89	35.33	34.79	43.12	42.44	41.72
	T/R	10.40	9.90	9.40	13.70	13.20	12.60	17.20	16.70	16.20	21.60	20.80	20.10	25.40	25.00	24.60	29.70	29.20	28.70	34.50	33.90	33.30	40.40	39.70	38.90
	AMPS*	8.67	9.07	9.49	9.23	9.65	10.09	9.74	10.18	10.63	10.28	10.69	11.15	10.70	11.20	11.72	11.17	11.69	12.22	11.73	12.26	12.80	12.48	13.00	13.55
	HI PR	217	232	248	228	244	260	241	257	274	258	273	290	273	291	310	291	309	329	312	331	351	339	358	378
	LO PR	31	31	32	41	41	42	52	53	53	65	65	66	79	79	80	95	95	96	112	113	113	132	133	133
1200	MBH†	9.14	8.76	8.33	12.39	12.00	11.56	16.11	15.69	15.24	20.77	20.46	19.51	25.17	24.83	24.50	30.31	29.88	29.45	36.38	35.81	35.25	43.81	43.10	42.38
	T/R	9.20	8.80	8.40	12.10	11.70	11.20	15.30	14.80	14.40	19.10	18.70	17.80	22.40	22.10	21.70	26.20	25.80	25.40	30.60	30.10	29.50	35.90	35.20	34.60
	AMPS*	8.72	9.12	9.54	9.25	9.67	10.12	9.72	10.16	10.62	10.20	10.68	11.09	10.58	11.08	11.59	11.00	11.50	12.03	11.51	12.02	12.56	12.19	12.71	13.25
	HI PR	214	229	245	223	239	256	235	251	268	250	268	283	264	282	301	279	298	317	299	318	337	323	343	362
	LO PR	31	31	32	41	41	41	52	52	53	65	65	65	79	79	79	94	95	95	112	112	113	132	132	133
1350	MBH†	9.28	8.90	8.46	12.54	12.16	11.72	16.30	15.89	15.43	20.95	20.64	19.79	25.39	25.05	24.70	30.60	30.16	29.73	36.78	36.19	35.63	44.35	43.60	42.90
	T/R	8.30	8.00	7.60	10.90	10.50	10.10	13.70	13.30	12.90	17.10	16.80	16.10	20.10	19.80	19.50	23.60	23.20	22.80	27.50	27.00	26.50	32.30	31.70	31.10
	AMPS*	8.79	9.20	9.62	9.30	9.72	10.16	9.73	10.18	10.63	10.18	10.65	11.07	10.52	11.01	11.52	10.91	11.40	11.93	11.38	11.88	12.41	12.01	12.53	13.07
	HI PR	211	227	243	220	236	253	230	247	264	244	262	277	256	274	293	271	289	308	289	307	327	312	331	350
	LO PR	31	31	32	41	41	41	52	52	53	64	65	65	79	79	79	94	95	95	112	112	112	132	132	133

See Legend and Notes on Page 19.

PHR542 EXTENDED HEATING PERFORMANCE – LOW HEAT

CFM		OUTDOOR AMBIENT TEMPERATURE deg F, Dry Bulb																							
		-10 (-23.3°C)			0 (-17.7°C)			10 (-12.2°C)			20 (-6.7°C)			30 (-1.1°C)			40 (-4.4°C)			50 (10°C)			60 (-15.6°C)		
		65	70	75	65	70	75	65	70	75	65	70	75	65	70	75	65	70	75	65	70	75	65	70	75
915	MBH†	6.31	5.92	5.50	9.04	8.66	8.23	12.13	11.79	11.35	15.70	15.35	14.93	20.29	19.49	19.01	24.62	24.31	23.97	29.49	29.09	28.67	35.11	34.59	34.06
	T/R	9.00	8.40	7.80	12.40	11.90	11.20	16.10	15.60	15.00	20.10	19.60	19.00	25.20	24.10	23.50	29.60	29.20	28.70	34.40	33.90	33.30	39.80	39.10	38.40
	AMPS*	8.11	8.43	8.77	8.34	8.70	9.06	8.61	8.99	9.38	8.92	9.32	9.74	9.33	9.69	10.13	9.65	10.12	10.61	9.97	10.45	10.96	10.32	10.80	11.31
	HI PR	206	221	236	218	233	249	231	247	263	246	263	280	266	281	299	285	303	323	306	325	344	330	349	369
	LO PR	34	35	35	45	45	45	57	57	57	70	71	71	85	86	86	102	103	103	121	122	122	142	142	143
1050	MBH†	6.44	6.06	5.64	9.18	8.83	8.42	12.35	11.99	11.58	15.98	15.61	15.19	20.62	19.90	19.35	24.92	24.61	24.28	29.90	29.49	29.08	35.67	35.14	34.61
	T/R	8.00	7.50	7.00	11.00	10.50	10.00	14.30	13.80	13.30	17.80	17.40	16.90	22.30	21.50	20.80	26.10	25.70	25.30	30.40	29.90	29.40	35.20	34.60	34.00
	AMPS*	8.22	8.54	8.89	8.42	8.78	9.14	8.66	9.04	9.43	8.93	9.32	9.74	9.29	9.65	10.09	9.54	10.00	10.49	9.81	10.27	10.77	10.09	10.57	11.07
	HI PR	204	219	234	215	230	246	226	242	259	240	256	274	258	273	290	274	292	311	292	311	330	314	333	353
	LO PR	34	35	35	45	45	45	57	57	57	70	71	71	85	86	86	102	102	103	121	121	122	141	142	142
1180	MBH†	6.56	6.18	5.78	9.34	8.98	8.57	12.53	12.16	11.77	16.19	15.82	15.42	20.83	20.46	19.63	25.18	24.86	24.54	30.24	29.82	29.40	36.11	35.58	35.05
	T/R	7.20	6.80	6.30	9.90	9.50	9.10	12.90	12.50	12.00	16.10	15.70	15.20	20.00	19.60	18.80	23.50	23.10	22.80	27.40	26.90	26.50	31.70	31.20	30.60
	AMPS*	8.33	8.66	9.01	8.51	8.87	9.24	8.73	9.10	9.50	8.97	9.36	9.78	9.28	9.70	10.08	9.51	9.95	10.43	9.74	10.19	10.67	9.97	10.43	10.92
	HI PR	203	218	233	212	228	244	223	239	255	235	252	269	251	268	284	265	284	303	282	301	320	302	321	341
	LO PR	34	35	35	45	45	45	57	57	57	70	70	71	85	85	86	102	102	103	120	121	121	141	141	142

PHR542 EXTENDED HEATING PERFORMANCE – HIGH HEAT

CFM		OUTDOOR AMBIENT TEMPERATURE deg F, Dry Bulb																							
		-10 (-23.3°C)			0 (-17.7°C)			10 (-12.2°C)			20 (-6.7°C)			30 (-1.1°C)			40 (-4.4°C)			50 (10°C)			60 (-15.6°C)		
		65	70	75	65	70	75	65	70	75	65	70	75	65	70	75	65	70	75	65	70	75	65	70	75
1225	MBH†	12.38	12.00	11.58	16.20	15.81	15.39	20.94	20.68	19.77	25.45	25.14	24.82	30.72	30.32	29.92	36.92	36.37	35.85	44.40	43.69	43.00	53.33	52.49	51.60
	T/R	12.50	12.00	11.60	15.80	15.30	14.90	19.70	19.40	18.50	23.20	22.90	22.50	27.20	26.80	26.40	31.70	31.20	30.70	37.10	36.40	35.70	43.30	42.50	41.70
	AMPS*	10.62	11.08	11.57	11.21	11.68	12.19	11.87	12.37	12.83	12.44	12.97	13.54	13.06	13.62	14.21	13.79	14.37	14.98	14.70	15.30	15.95	15.90	16.55	17.23
	HI PR	221	237	254	234	250	267	249	267	282	264	282	301	281	299	318	301	320	339	327	346	365	360	380	400
	LO PR	32	32	32	42	42	42	53	53	53	65	66	66	79	80	80	95	95	96	113	113	114	134	134	135
1400	MBH†	12.54	12.18	11.76	16.40	16.02	15.61	21.12	20.87	20.08	25.69	25.38	25.07	31.04	30.63	30.23	37.35	36.81	36.26	44.96	44.28	43.56	53.96	53.14	52.28
	T/R	11.00	10.70	10.30	14.00	13.60	13.20	17.40	17.20	16.50	20.50	20.20	19.90	24.00	23.70	23.30	28.10	27.60	27.10	32.80	32.30	31.70	38.30	37.70	37.00
	AMPS*	10.68	11.15	11.64	11.24	11.71	12.22	11.85	12.36	12.82	12.38	12.90	13.46	12.96	13.50	14.08	13.63	14.20	14.79	14.50	15.09	15.71	15.62	16.33	16.98
	HI PR	218	234	250	229	245	262	243	261	276	256	274	293	271	289	309	290	308	328	314	333	352	346	367	387
	LO PR	32	32	32	42	42	42	52	53	53	65	65	66	79	80	80	95	95	96	113	113	114	133	134	134
1575	MBH†	12.70	12.34	11.93	16.57	16.21	15.80	21.30	21.05	20.39	25.90	25.59	25.27	31.32	30.91	30.49	37.71	37.16	36.61	45.36	44.67	43.98	53.92	53.30	52.60
	T/R	9.90	9.60	9.30	12.50	12.20	11.90	15.60	15.40	14.90	18.40	18.10	17.90	21.60	21.20	20.90	25.20	24.80	24.40	29.50	28.90	28.40	34.00	33.60	33.10
	AMPS*	10.77	11.23	11.73	11.30	11.77	12.28	11.88	12.38	12.86	12.38	12.90	13.45	12.92	13.46	14.03	13.57	14.13	14.71	14.45	15.02	15.62	15.57	16.18	16.83
	HI PR	215	231	248	225	242	259	238	255	272	250	268	286	264	282	301	282	300	319	307	325	344	338	357	377
	LO PR	32	32	32	41	42	42	52	53	53	65	65	66	79	79	80	95	95	95	113	113	113	132	133	134

See Legend and Notes on Page 19.

PHR548 EXTENDED HEATING PERFORMANCE – LOW HEAT

		OUTDOOR AMBIENT TEMPERATURE deg F, Dry Bulb																								
		-8 (-22.2°C)			0 (-17.7°C)			10 (-12.2°C)			20 (-6.7°C)			30 (-1.1°C)			40 (-4.4°C)			50 (10°C)			60 (-15.6°C)			
		65	70	75	65	70	75	65	70	75	65	70	75	65	70	75	65	70	75	65	70	75	65	70	75	
CFM	1050	MBH†	7.73	7.14	7.13	11.11	10.58	9.98	14.97	14.45	13.89	19.32	18.80	18.25	24.76	23.87	23.17	29.74	29.36	28.97	35.43	34.95	34.46	41.98	41.35	40.76
		T/R	8.40	7.70	7.70	11.80	11.20	10.50	15.50	14.90	14.30	19.40	18.90	18.30	24.30	23.30	22.60	28.40	28.00	27.60	33.10	32.60	32.00	38.30	37.60	37.00
		AMPS*	8.64	9.05	9.52	9.04	9.48	9.92	9.47	9.94	10.41	9.92	10.40	10.90	10.45	10.91	11.42	10.86	11.43	12.03	11.30	11.90	12.53	11.82	12.44	13.09
		HI PR	205	219	236	216	231	246	229	244	260	243	259	276	262	277	294	278	296	315	297	316	335	320	339	359
		LO PR	33	33	36	43	43	44	55	55	55	68	68	68	82	82	83	98	99	99	117	117	118	136	137	138
CFM	1200	MBH†	7.91	7.36	7.34	11.33	10.82	10.23	15.24	14.75	14.18	19.64	19.14	18.59	25.09	24.71	23.59	30.12	29.73	29.34	35.92	35.44	34.94	42.67	42.01	41.38
		T/R	7.50	7.00	6.90	10.50	10.00	9.40	13.80	13.30	12.70	17.30	16.80	16.30	21.50	21.20	20.10	25.20	24.80	24.40	29.30	28.90	28.40	34.00	33.40	32.90
		AMPS*	8.78	9.20	9.67	9.14	9.59	10.04	9.54	10.02	10.49	9.94	10.43	10.94	10.41	10.95	11.40	10.76	11.32	11.92	11.13	11.72	12.34	11.57	12.18	12.82
		HI PR	203	218	235	213	228	244	224	240	256	237	253	270	253	271	286	268	286	305	285	303	323	305	324	343
		LO PR	33	33	36	43	43	44	55	55	55	68	68	68	82	82	83	98	99	99	116	117	117	136	137	137
CFM	1310	MBH†	8.06	7.50	7.49	11.50	10.99	10.39	15.42	14.94	14.37	19.86	19.37	18.82	25.30	24.94	23.90	30.37	29.99	29.58	36.23	35.74	35.25	43.10	42.43	41.77
		T/R	7.00	6.50	6.50	9.80	9.30	8.80	12.80	12.30	11.80	16.00	15.60	15.10	19.90	19.60	18.70	23.30	22.90	22.60	27.10	26.70	26.20	31.50	30.90	30.40
		AMPS*	8.89	9.32	9.79	9.24	9.69	10.14	9.61	10.09	10.57	9.99	10.48	10.99	10.42	10.95	11.42	10.73	11.30	11.89	11.07	11.66	12.27	11.47	12.07	12.70
		HI PR	202	217	234	211	226	242	222	237	254	233	250	267	248	266	282	262	280	298	277	296	315	297	315	335
		LO PR	33	33	36	43	43	44	55	55	55	68	68	68	82	82	83	98	99	99	116	116	117	136	136	137

PHR548 EXTENDED HEATING PERFORMANCE – HIGH HEAT

		OUTDOOR AMBIENT TEMPERATURE deg F, Dry Bulb																								
		-10 (-23.3°C)			0 (-17.7°C)			10 (-12.2°C)			20 (-6.7°C)			30 (-1.1°C)			40 (-4.4°C)			50 (10°C)			60 (-15.6°C)			
		65	70	75	65	70	75	65	70	75	65	70	75	65	70	75	65	70	75	65	70	75	65	70	75	
CFM	1400	MBH†	14.53	14.00	13.37	19.50	18.97	18.38	25.15	24.76	23.58	30.02	29.67	29.28	35.53	35.05	34.59	41.86	41.24	40.64	49.38	48.65	47.91	57.39	56.80	56.18
		T/R	10.50	10.10	9.60	14.10	13.70	13.20	18.10	17.70	16.90	21.50	21.20	20.80	25.30	24.90	24.50	29.60	29.10	28.60	34.80	34.20	33.60	40.20	39.70	39.20
		AMPS*	11.09	11.54	12.02	11.71	12.21	12.74	12.46	13.03	13.53	13.16	13.78	14.43	13.96	14.61	15.30	14.89	15.58	16.30	16.03	16.75	17.51	17.24	18.02	18.84
		HI PR	214	230	246	227	243	260	242	259	275	255	273	292	270	289	308	289	307	327	312	331	351	338	358	379
		LO PR	30	30	31	39	39	40	49	50	50	61	61	62	75	75	75	90	90	90	107	107	108	124	125	126
CFM	1600	MBH†	14.79	14.26	13.63	19.77	19.26	18.68	25.42	25.08	23.94	30.34	29.97	29.61	35.92	35.46	34.97	42.35	41.74	41.13	49.83	49.26	48.49	56.49	56.11	55.71
		T/R	9.40	9.00	8.60	12.50	12.10	11.70	16.00	15.70	15.00	19.00	18.70	18.40	22.40	22.00	21.70	26.20	25.80	25.40	30.70	30.30	29.70	34.60	34.30	34.00
		AMPS*	11.22	11.68	12.16	11.80	12.30	12.83	12.50	13.06	13.57	13.15	13.76	14.40	13.89	14.54	15.21	14.77	15.44	16.14	15.76	16.50	17.31	16.94	17.71	18.51
		HI PR	211	227	243	223	239	256	236	254	269	248	266	284	262	280	299	279	297	316	299	318	339	324	344	364
		LO PR	30	30	31	39	39	39	49	49	50	61	61	62	74	75	75	89	90	90	106	107	107	121	122	124
CFM	1800	MBH†	15.01	14.49	13.87	20.02	19.53	18.95	25.66	25.33	24.26	30.62	30.26	29.88	36.26	35.80	35.31	42.74	42.14	41.53	49.29	49.00	48.62	55.21	55.02	54.73
		T/R	8.50	8.20	7.80	11.20	10.90	10.60	14.30	14.10	13.50	17.00	16.80	16.50	20.10	19.80	19.40	23.50	23.10	22.80	27.00	26.80	26.50	30.10	29.90	29.70
		AMPS*	11.37	11.83	12.31	11.92	12.42	12.95	12.57	13.14	13.65	13.19	13.80	14.43	13.91	14.54	15.21	14.76	15.42	16.11	15.69	16.40	17.14	16.83	17.59	18.38
		HI PR	209	225	241	219	236	253	232	249	265	242	260	279	255	273	292	272	290	308	290	309	328	314	334	354
		LO PR	30	30	31	39	39	39	49	49	50	61	61	62	74	75	75	89	90	90	104	105	106	117	119	121

See Legend and Notes on Page 19.

PHR560 EXTENDED HEATING PERFORMANCE – LOW HEAT

CFM		OUTDOOR AMBIENT TEMPERATURE deg F, Dry Bulb																																															
		-10 (-23.3°C)						0 (-17.7°C)						10 (-12.2°C)						20 (-6.7°C)						30 (-1.1°C)						40 (-4.4°C)						50 (10°C)						60 (-15.6°C)					
		65	70	75	65	70	75	65	70	75	65	70	75	65	70	75	65	70	75	65	70	75	65	70	75	65	70	75	65	70	75	65	70	75	65	70	75												
1200	MBH†	9.60	8.87	8.07	13.75	13.07	12.34	18.28	17.65	16.96	23.27	22.63	21.96	29.47	28.19	27.47	34.90	34.46	34.00	40.90	40.36	39.82	47.80	47.09	46.37																								
	T/R	8.50	7.80	7.10	12.00	11.40	10.70	15.80	15.20	14.60	19.90	19.30	18.70	25.00	23.90	23.20	29.30	28.90	28.40	34.10	33.50	33.00	39.40	38.80	38.10																								
	AMPS*	11.58	12.17	12.75	11.92	12.52	13.13	12.23	12.86	13.50	12.54	13.18	13.84	12.99	13.52	14.21	13.23	13.97	14.74	13.52	14.27	15.05	13.89	14.66	15.45																								
	HI PR	207	221	236	219	234	249	233	249	265	249	265	282	270	284	301	288	307	326	309	328	348	335	354	374																								
	LO PR	34	35	35	45	45	45	56	57	57	69	70	70	84	85	85	101	101	102	119	119	120	139	140	140																								
1400	MBH†	9.81	9.07	8.29	14.02	13.34	12.59	18.61	17.97	17.28	23.65	23.03	22.36	29.87	28.69	27.95	35.33	34.88	34.45	41.47	40.92	40.38	48.64	47.90	47.15																								
	T/R	7.40	6.80	6.20	10.50	10.00	9.40	13.80	13.30	12.70	17.40	16.90	16.30	21.70	20.80	20.20	25.40	25.10	24.70	29.60	29.10	28.70	34.40	33.80	33.20																								
	AMPS*	11.71	12.30	12.91	11.99	12.61	13.22	12.23	12.87	13.52	12.46	13.12	13.79	12.83	13.37	14.05	12.98	13.70	14.47	13.16	13.90	14.68	13.42	14.18	14.97																								
	HI PR	205	219	234	216	231	246	228	243	260	241	258	275	260	274	292	276	294	314	295	313	333	317	336	356																								
	LO PR	34	35	35	45	45	45	56	57	57	69	70	70	84	84	85	100	101	101	118	119	120	139	139	140																								
1545	MBH†	9.97	9.23	8.45	14.20	13.52	12.78	18.83	18.18	17.50	23.92	23.29	22.62	30.11	29.10	28.27	35.61	35.15	34.71	41.82	41.27	40.72	49.14	48.38	47.63																								
	T/R	6.80	6.30	5.80	9.60	9.10	8.60	12.60	12.20	11.70	15.90	15.50	15.00	19.80	19.10	18.50	23.20	22.90	22.60	27.00	26.60	26.20	31.50	30.90	30.40																								
	AMPS*	11.82	12.42	13.03	12.06	12.69	13.31	12.27	12.91	13.57	12.46	13.12	13.79	12.77	13.34	14.01	12.87	13.58	14.34	13.01	13.73	14.50	13.21	13.95	14.73																								
	HI PR	204	218	233	214	229	244	225	240	257	237	254	271	254	269	286	269	288	307	287	305	325	307	326	346																								
	LO PR	34	35	35	44	45	45	56	56	57	69	70	70	84	84	85	100	101	101	118	119	119	139	139	140																								

PHR560 EXTENDED HEATING PERFORMANCE – HIGH HEAT

CFM		OUTDOOR AMBIENT TEMPERATURE deg F, Dry Bulb																																															
		-10 (-23.3°C)						0 (-17.7°C)						10 (-12.2°C)						20 (-6.7°C)						30 (-1.1°C)						40 (-4.4°C)						50 (10°C)						60 (-15.6°C)					
		65	70	75	65	70	75	65	70	75	65	70	75	65	70	75	65	70	75	65	70	75	65	70	75	65	70	75	65	70	75	65	70	75	65	70	75												
1750	MBH†	17.80	17.37	16.92	23.12	22.62	22.13	29.49	29.17	28.05	35.51	35.11	34.74	42.61	42.05	41.51	50.89	50.17	49.47	60.88	59.99	59.13	72.89	71.93	70.88																								
	T/R	11.60	11.30	11.00	14.70	14.30	14.00	18.20	18.00	17.30	21.40	21.10	20.80	25.10	24.70	24.30	29.20	28.70	28.30	34.10	33.60	33.00	39.90	39.30	38.70																								
	AMPS*	13.44	14.05	14.68	14.11	14.72	15.37	15.02	15.68	16.23	15.91	16.59	17.32	16.94	17.65	18.40	18.13	18.87	19.66	19.55	20.34	21.19	21.26	22.23	23.15																								
	HI PR	220	237	253	232	249	266	248	266	281	262	280	299	279	297	316	299	318	337	324	343	364	357	378	398																								
	LO PR	32	32	32	41	41	41	52	52	52	64	64	65	78	78	79	94	94	94	111	112	112	131	132	132																								
2000	MBH†	18.09	17.67	17.23	23.46	22.97	22.48	29.85	29.52	28.55	35.90	35.49	35.11	43.12	42.55	41.99	51.52	50.79	50.07	61.59	60.73	59.86	73.28	72.49	71.62																								
	T/R	10.30	10.10	9.80	13.00	12.70	12.40	16.10	15.90	15.40	18.90	18.70	18.40	22.20	21.90	21.50	25.90	25.50	25.00	30.20	29.70	29.20	35.10	34.70	34.20																								
	AMPS*	13.65	14.27	14.91	14.29	14.91	15.55	15.16	15.82	16.38	16.01	16.69	17.40	17.00	17.70	18.44	18.14	18.88	19.64	19.52	20.30	21.12	21.14	22.02	22.95																								
	HI PR	217	233	250	228	245	262	243	260	276	255	273	292	271	289	308	289	308	327	313	332	352	345	365	385																								
	LO PR	31	32	32	41	41	41	52	52	52	64	64	65	78	78	79	93	94	94	111	111	112	130	131	132																								
2250	MBH†	18.38	17.95	17.51	23.78	23.30	22.80	30.14	29.84	29.46	36.27	35.85	35.45	43.57	42.99	42.42	52.05	51.31	50.58	62.16	61.29	60.44	73.30	72.59	71.82																								
	T/R	9.30	9.10	8.80	11.70	11.50	11.20	14.50	14.30	14.10	17.00	16.80	16.50	19.90	19.60	19.30	23.20	22.90	22.50	27.10	26.70	26.20	31.20	30.90	30.50																								
	AMPS*	13.89	14.52	15.15	14.50	15.13	15.77	15.35	16.01	16.68	16.17	16.85	17.56	17.14	17.84	18.56	18.28	18.99	19.74	19.67	20.42	21.22	21.25	22.09	22.99																								
	HI PR	215	231	248	225	241	259	238	256	274	250	268	286	265	282	301	282	301	320	307	325	345	338	357	377																								
	LO PR	31	32	32	41	41	41	51	52	52	64	64	64	78	78	78	93	94	94	111	111	112	129	130	131																								

LEGEND

- † Total capacities are net (I.D blower heat subtracted) system capacities based on 25' line set. If additional tubing length and/or indoor unit is located above outdoor unit, a slight variation in capacity may occur.
- * System amps are total of indoor and outdoor amps
- ‡ S/T are based on 80 F db entering air at the indoor coil. For sensible capacities at other than 80 F db, deduct 835 Btu/h per 1000 cfm of indoor coil air from MBHxS/T for each degree below 80 F, or add 835 Btu/h per 1000 cfm of indoor coil air from MBHxS/T for each degree above 80 F
- †† At TVA rating indoor condition (75 F db/ 63 F wb). All other indoor air temperatures are at 80 F db

UNIT DIMENSIONS - PHR524-30

REQUIRED CLEARANCES TO COMBUSTIBLE MITL

	INCHES (MM)
TOP OF UNIT.....	14 (355.6)
DUCT SIDE OF UNIT.....	2 (50.8)
SIDE OPPOSITE DUCTS.....	6 (152.4)
ELECTRICAL PANEL.....	36 (914.4)

MIN. REQUIRED CLEARANCES

	INCHES (MM)
BETWEEN UNITS, POWER ENTRY SIDE.....	36 (914.4)
UNIT AND UNGROUND SURFACES, POWER ENTRY SIDE.....	36 (914.4)
UNIT AND BLOCK OR CONCRETE WALLS AND OTHER GROUND SURFACES, POWER ENTRY SIDE.....	42 (1066.8)

REQUIRED CLEARANCE FOR OPERATION AND SERVICE

	INCHES (MM)
EVAP. COIL ACCESS SIDE.....	36 (914.4)
POWER ENTRY SIDE.....	42 (1066.8)
RECEPTOR FOR WIRE REQUIREMENTS.....	48 (1219.2)
DUCT SIDE OPPOSITE DUCTS.....	36 (914.4)
DUCT PANEL.....	12 (304.8)

*MINIMUM DISTANCES: IF UNIT IS PLACED LESS THAN 12 (304.8) FROM WALL SYSTEM, THEN SYSTEM PERFORMANCE MAY BE COMPROMISED. DIMENSIONS IN () ARE IN MILLIMETERS

UNIT	ELECTRICAL CHARACTERISTICS		UNIT WT.		CENTER OF GRAVITY IN/MM							
	VOLTS	AMPS	LB	KG	X	Y	Z	X	Y	Z		
PHR524000KTP0B1	208/230	1-60	338	153.3	51-3/4	1315	20-1/2	520.7	15-3/4	400.1	23.0	584.2
PHR530000KTP0B1	208/230	1-60	384	174.2	51-3/4	1315	20-1/2	520.7	15-3/4	400.1	23.0	584.2
PHR530000H000B1	208/230	3-60	384	174.2	51-3/4	1315	20-1/2	520.7	15-3/4	400.1	23.0	584.2

UNIT	VOLTAGE	1"*	2"*	3"*	4"*
PHR524000KTP0B1	208/230	47.3	21.5	60.8	27.6
PHR530000KTP0B1	208/230	53.8	24.4	69.1	31.4
PHR530000H000B1	208/230	53.8	24.4	69.1	31.4

NOTE: ALL TABLE DATA RELEVANT FOR ALL FACTORY INSTALLED OPTIONS EXCEPT ECONOMIZER

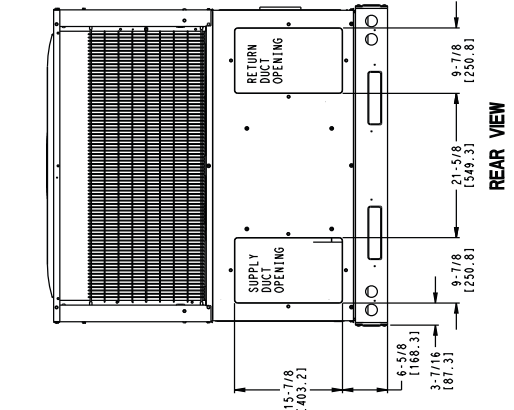
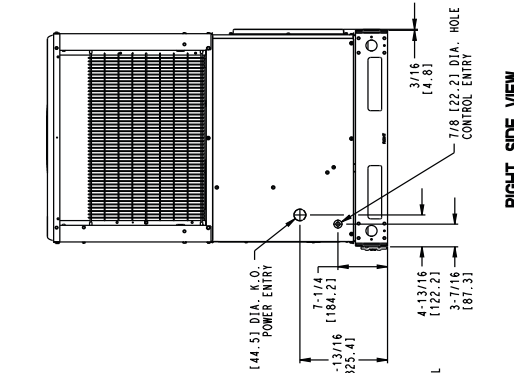
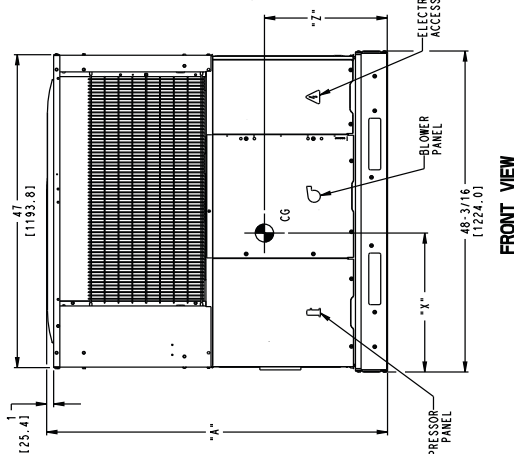
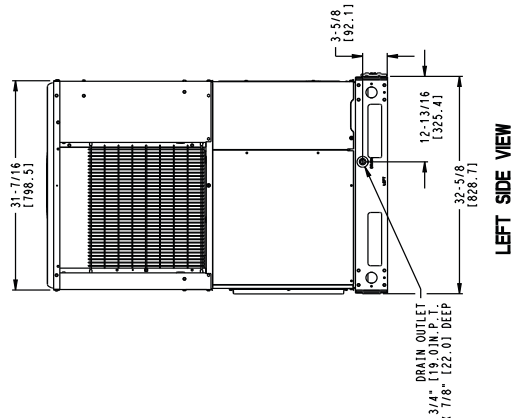
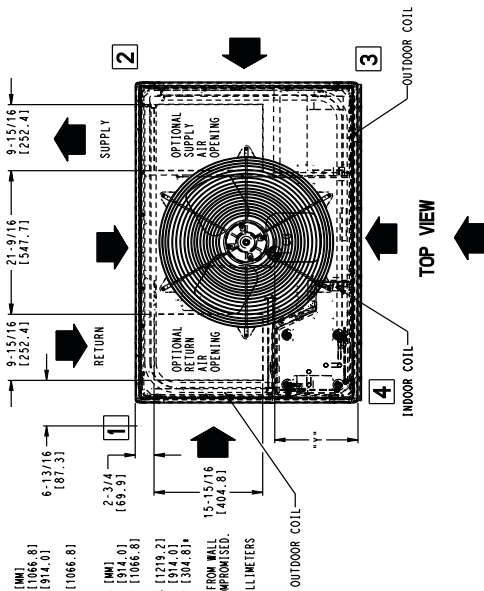

50CY502973

UNIT DIMENSIONS - PHR536-60

UNIT	ELECTRICAL CHARACTERISTICS		UNIT WT.		UNIT HEIGHT IN MM		CENTER OF GRAVITY IN MM	
	VOLTAG	AMPS	LB	KG	"A"	"Z"	X	Y
PHR536000(K, H1**0A1)	208/230	49.6	128.1	58.1	37.5	89.1	156.2	165.6
PHR542000(K, H1**0A1)	208/230	53.3	130.2	60.4	40.3	106.6	177.6	170.5
PHR548000(K, H1**0A1)	208/230	53.6	130.4	60.4	40.3	106.6	177.6	170.5
PHR560000(K, H1**0A1)	208/230	60.4	134.2	60.5	45.6	120.7	168.4	201.2

UNIT	CORNER WEIGHTS LB/KG			
	"1"	"2"	"3"	"4"
PHR536000(K, H1**0A1)	49.6	128.1	58.1	37.5
PHR542000(K, H1**0A1)	53.3	130.2	60.4	40.3
PHR548000(K, H1**0A1)	53.6	130.4	60.4	40.3
PHR560000(K, H1**0A1)	60.4	134.2	60.5	45.6

NOTE: ALL TABLE DATA RELEVANT FOR ALL FACTORY INSTALLED OPTIONS EXCEPT ECONOMIZER.

REQUIRED CLEARANCES TO COMBUSTIBLE MATL.

	INCHES (MM)
TOP OF UNIT	2 (50.8)
DUCT SIDE OF UNIT	14 (355.6)
SIDE OPPOSITE DUCTS	0 (0.0)
BOTTOM OF UNIT	36 (914.4)
ELECTRICAL PANEL	36 (914.4)

NEC REQUIRED CLEARANCES

	INCHES (MM)
BETWEEN UNITS, POWER ENTRY SIDE	42 (1066.8)
UNIT AND UNGROUNDED SURFACES, POWER ENTRY SIDE	36 (914.0)
UNIT AND BLOCK OR CONCRETE WALLS AND OTHER GROUNDED SURFACES, POWER ENTRY SIDE	42 (1066.8)

REQUIRED CLEARANCE FOR OPERATION AND SERVICING

	INCHES (MM)
EVAP. COIL ACCESS SIDE	36 (914.0)
POWER SUPPLY	42 (1066.8)
EXCEPT FOR NEC REQUIREMENTS	48 (1219.2)
UNIT TOP	36 (914.0)
SIDE OPPOSITE DUCTS	36 (914.0)
DUCT PANEL	12 (304.8)

*MINIMUM DISTANCES: IF UNIT IS PLACED LESS THAN 12 (304.8) FROM WALL SYSTEM, THEN SYSTEM PERFORMANCE MAYBE COMPROMISED. DIMENSIONS IN () ARE IN MM

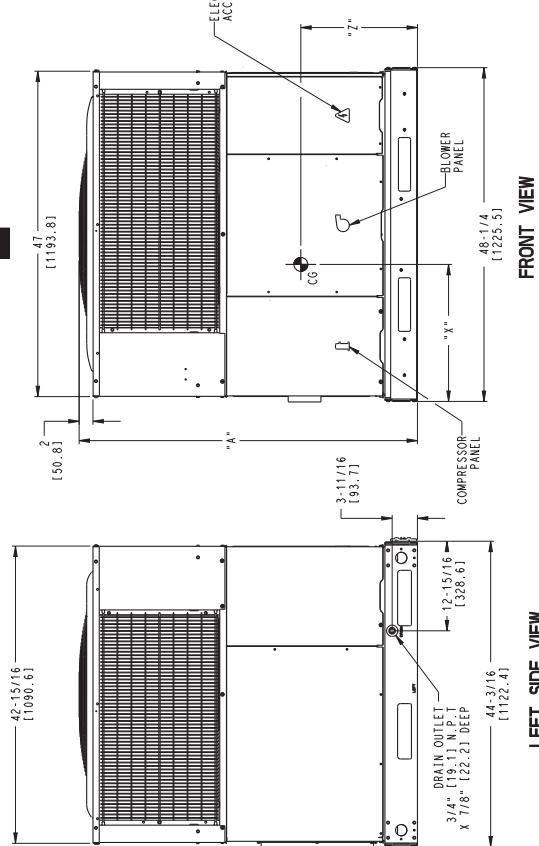
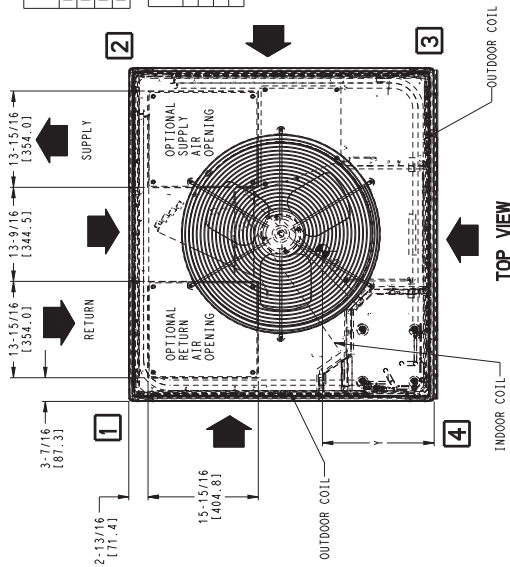

CONTROLS

SEQUENCE OF OPERATION

- a. Continuous Fan
 - (1.) Thermostat closes circuit R to G energizing the blower motor for continuous fan. The indoor fan is energized on low speed.
- b. Cooling Mode
 - (1.) Low Stage: Thermostat closes R to G, R to Y1, and R to O. The compressor and indoor fan are energized on low speed. The outdoor fan is also energized
 - (2.) High Stage: Thermostat closes R to G, R to Y1, R to Y2, and R to O. The compressor and indoor fan are energized on high speed. The outdoor fan is also energized.
- c. Electric Heating Mode
 - (1.) Thermostat closes circuit R to W2 or W3, and R to G. There are no on or off delays.
- d. Heat Pump Heating
 - (1.) Low Stage: Thermostat closes R to G, R to Y1. The compressor and indoor fan are energized on low speed. The outdoor fan is also energized
 - (2.) High Stage: Thermostat closes R to G, R to Y1, R to Y2. The compressor and indoor fan are energized on high speed. The outdoor fan is also energized.
- e. Heat Pump Heating with Auxiliary Heat
 - (1.) Thermostat closes circuits R to G, R to Y and R to W/W1 or W2. The compressor, indoor and outdoor fans are energized, as well as the electric heat relays.
- f. Defrost Mode

The defrost mode is automatically energized by the defrost board during heating mode. The defrost board energizes "O" (reversing valve) and "W2" (electric heat). It also de-energizes the outdoor fan. When defrost is complete, unit will return to heating mode. If room thermostat is satisfied during defrost, unit will shut down and restart in defrost on next call for heat.

GUIDE SPECIFICATIONS

Packaged Air Conditioner System Constant Volume Application HVAC Guide Specifications

Size Range: **2 to 5 Tons, Nominal Cooling**

Model Number: PHR5

Part 1 — General

SYSTEM DESCRIPTION

Outdoor rooftop mounted or ground mounted, electric cooling unit utilizing a hermetic 2-stage scroll compressor for cooling duty. Unit shall discharge supply air vertically or horizontally as shown on contract drawings. Condenser fan/coil section shall have a draw-thru design with vertical discharge for minimum sound levels.

QUALITY ASSURANCE

- A. Unit shall be rated in accordance with AHRI Standards 210/240 and 270.**
- B. Unit shall be designed in accordance with UL Standard 1995.**
- C. Unit shall be manufactured in a facility registered to ISO 9001 manufacturing quality standard.**

- D. Unit shall be UL listed and c-UL certified as a total package for safety requirements.**
- E. Roof curb shall be designed to conform to NRCA Standards.**
- F. Insulation and adhesives shall meet NFPA 90A requirements for flame spread and smoke generation.**
- G. Cabinet insulation shall meet ASHRAE Standard 62P.**

DELIVERY, STORAGE AND HANDLING

Unit shall be stored and handled per manufacturer's recommendations.

Part 2 — Products

EQUIPMENT

A. General:

Factory-assembled, single-piece, heating and cooling unit. Contained within the enclosure shall be all factory wiring, piping, controls, refrigerant charge with R-410A refrigerant, and special features required prior to field start-up.

B. Unit Cabinet:

1. Unit cabinet shall be constructed of phosphated, zinc-coated, pre-painted steel capable of with-standing 500 hours in salt spray.
2. Normal service shall be through a single removable cabinet panel.
3. The unit shall be constructed on a rust proof unit base that has an externally trapped, integrated sloped drain.
4. Evaporator fan compartment top surface shall be insulated with a minimum 1/2-in. (12.7 mm) thick, flexible fiberglass insulation, coated on the air side and retained by adhesive and mechanical means. The evaporator wall sections will be insulated with a minimum semi-rigid foil-faced board capable of being wiped clean. Aluminum foil-faced fiberglass insulation shall be used in the entire indoor air cavity section.
5. Unit shall have a field-supplied condensate trap.

C. Fans:

1. The evaporator fan shall be a multi-speed ECM Blower Motor.
2. Fan wheel shall be made from steel, be double-inlet type with forward curved blades with corrosion resistant finish. Fan wheel shall be dynamically balanced.
3. Condenser fan shall be direct drive propeller type with aluminum blades riveted to corrosion resistant steel spiders, be dynamically balanced, and discharge air vertically.

D. Compressor:

1. Fully hermetic compressors with factory-installed vibration isolation.
2. 2-Stage scroll compressor shall be standard on all units.

E. Coils:

Evaporator and condenser coils shall have aluminum plate fins mechanically bonded to seamless copper tubes with all joints brazed. Tube sheet openings shall be belled to prevent tube wear.

F. Refrigerant Components:

Refrigerant expansion device shall be of the TXV (thermostatic expansion valve) for cooling and fixed orifice for heating.

G. Filters:

Filter section shall consist of field-installed, throwaway, 1-in. (25 mm) thick fiberglass filters of commercially available sizes.

GUIDE SPECIFICATIONS (CONT.)

H. Controls and Safeties:

1. Unit controls shall be complete with a self-contained low voltage control circuit.
2. Compressors shall incorporate a solid-state compressor protector that provides reset capability.

I. Operating Characteristics:

1. Unit shall be capable of starting and running at 125°F (51°C) ambient outdoor temperature per maximum load criteria of AHRI Standard 210.
2. Compressor with standard controls shall be capable of operation down to 40°F (4°C) ambient outdoor temperature.
3. Units shall be provided with fan time delay to prevent cold air delivery before the heat exchanger warms up.
4. Unit shall be provided with 90-second fan time delay after the thermostat is satisfied.

J. Electrical Requirements:

All unit power wiring shall enter the unit cabinet at a single location.

K. Motors:

1. Compressor motors shall be of the refrigerant-cooled type with line-break thermal and current overload protection.
2. All fan motors shall have permanently lubricated bearings, and inherent, automatic reset, thermal overload protection.

L. Special Features Available:

1. Compressor Start Kit (single phase units only):
Shall provide additional starting torque for single-phase compressors.
2. Thermostat:
To provide for one-stage heating and cooling in addition manual or automatic changeover and indoor fan control.
3. Crankcase Heater Kit:
Shall provide anti-floodback protection for low-load cooling applications.
4. Economizer for 2-stage operation:
 - a. Economizer controls capable of providing free cooling using outside air.
 - b. Equipped with low leakage dampers not to exceed 3% leakage, at 1.0 IN. W.C. pressure differential.
 - c. Spring return motor shuts off outdoor damper on power failure.

5. Electric Heaters:

- a. Electric heater shall be available as a field-installed option.
- b. Heater elements shall be open wire type, adequately supported and insulated with ceramic bushings.
- c. Electric heater packages must provide single point power connection capability.

6. Filter Rack Option or Kit:

Shall provide filter mounting for downflow applications. Offered as an accessory or a factory installed option.

7. Flat Roof Curb Kit:

Curbs shall have seal strip and a wood nailer for flashing and shall be installed per manufacturer's instructions.

8. Low Ambient Package Kit:

Shall consist of a solid-state control and condenser coil temperature sensor for controlling condenser-fan motor operation, which shall allow unit to operate down to 0°F (-17.7°C) outdoor ambient temperature when properly installed.

9. Manual Outdoor Air Damper Kit:

Package shall consist of damper, birdscreen, and rainhood which can be preset to admit outdoor air for year-round ventilation.

10. Square-To-Round Duct Transitions Kit (24-48 size):

Shall have the ability to convert the supply and return openings from rectangular to round.

11. Cabinet Leakage:

Cabinet air leakage of 2.0% or less at .5 in. W.C. when tested in accordance with ASHRAE standard 193. Available as a factory installed option.

12. Dual Point Electric Heaters Kit

Allows you to power the electric heater and unit contactor separately by having two individual field power supply circuits connected respectively.

ACCESSORIES

ROOF CURBS

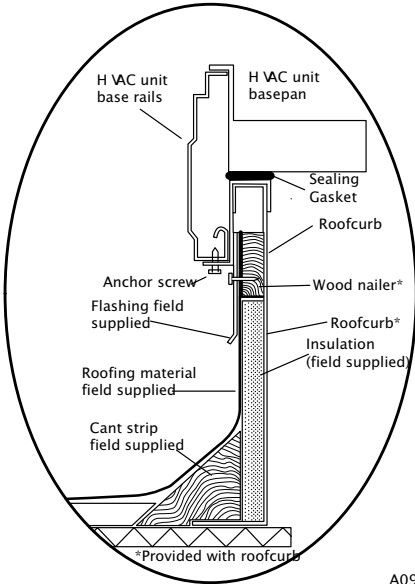

ROOF CURB DETAIL

A09090

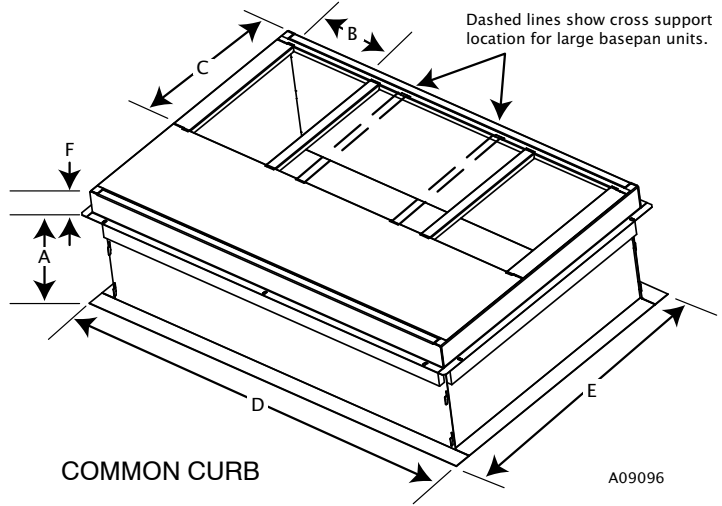

COMMON CURB

A09096

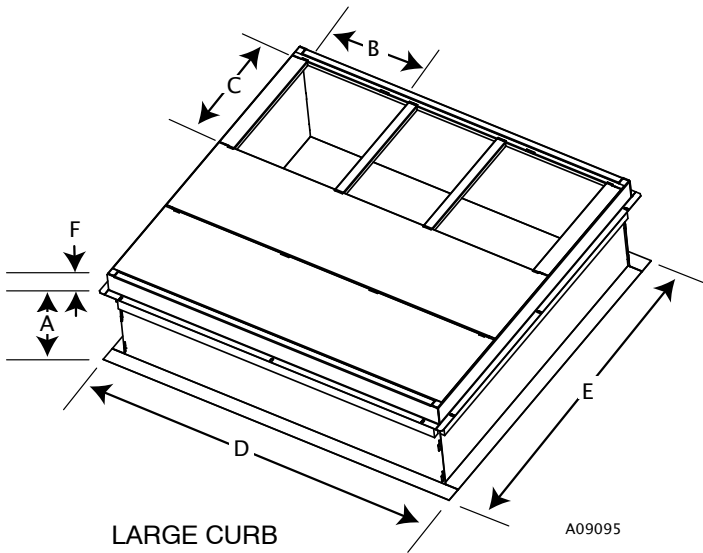

LARGE CURB

A09095

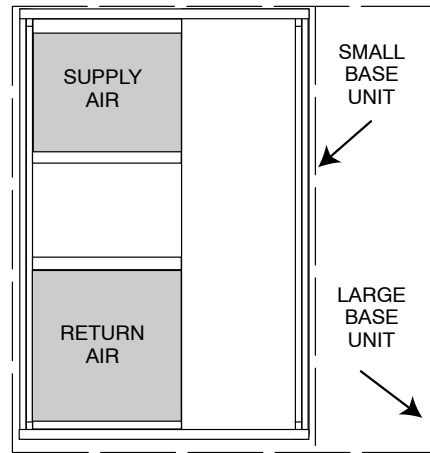

UNIT PLACEMENT ON COMMON CURB

A09094

SMALL OR LARGE BASE UNIT

UNIT SIZE	CATALOG NUMBER	A IN. (mm)	B (small base) IN. (mm)*	B (large base) IN. (mm)*	C IN. (mm)	D IN. (mm)	E IN. (mm)	F IN. (mm)
Small or Large	CPRFCURB011A00	14 (356)	10 (254)	14 (356)	16 (406)	47.8 (1214)	32.4 (822)	2.7 (69)
Large	CPRFCURB013A00	14 (356)	14 (356)	14 (356)	16 (406)	47.8 (1214)	43.9 (1116)	2.7 (69)

* Part Numbers CPRFCURB011A00 can be used on both small and large basepan units. The cross supports must be located based on whether the unit is a small basepan or a large basepan.

NOTES:

1. Roof curb must be set up for unit being installed.
2. Seal strip must be applied, as required, to unit being installed.
3. Roof curb is made of 16-gauge steel.
4. Attach ductwork to curb (flanges of duct rest on curb).
5. Insulated panels: 1-in. (25.4 mm) thick fiberglass 1 lb. density.

PHR5 ACCESSORIES								
Accessory Model Number		Description				Use With		
CURBS								
CPRFCURB011A00		Roof Curb, 14" High				ALL		
CPRFCURB013A00		Roof Curb, 14" High				36 – 60		
Note: CPRFCURB011A00 can be used with 36–60 size units with some overhang.								
ADAPTER CURBS*								
CPADCURB001A00		Adapter curb for use with NPRFCURB006A00 & NPRFCURB007A00				24 – 30		
CPADCURB002A00		Adapter curb for use with NPRFCURB008A00 & NPRFCURB009A00				36 – 60		
* Can also be used when replacing other manufacturer's older generation units that contain a composite base without a metal base rail.								
CONCENTRIC ADAPTERS – (Use with curb only)								
NPCONADP001A00		For 18" round duct (use with curb CPRFCURB011A00)				Small Curb		
NPCONADP002A00		For 18" round duct (use with curb CPRFCURB013A00)				Large Curb		
DAMPERS								
CPMANDPR007A00		Manual Outside Air Damper – (Includes filter rack and 1" filter, same as CPFILTRK kit)				24 – 30		
CPMANDPR008A00						36 – 42		
CPMANDPR009A00						48 – 60		
ECONOMIZER								
ECD-SDSML-JC2-ADB*		Vertical economizer with Jade Honeywell W7220 controller, Honeywell communicating actuator, and dry bulb sensor. (Contact MicroMetl Customer Service at 1-800-662-4822 to order)				24 – 30		
ECD-SDLGS-JC2-ADB*						36 – 42		
ECD-SDLGB-JC2-ADB*						48 – 60		
ECH-SDSML-JC2-ADB*		Horizontal economizer with Jade Honeywell W7220 controller, Honeywell communicating actuator, and dry bulb sensor. (Contact MicroMetl Customer Service at 1-800-662-4822 to order)				24 – 30		
ECH-SDLGS-JC2-ADB*						36 – 42		
ECH-SDLGB-JC2-ADB*						48 – 60		
* Contact MicroMetl Customer Service at 1-800-662-4822 to order.								
INTERNAL FILTER RACKS								
CPFILTRK007A00		Internal Filter Rack (includes 1-inch filters)				24 – 30		
CPFILTRK008A00						36 – 42		
CPFILTRK009A00						48 – 60		
LOW AMBIENT, ANTI-CYCLE TIMER, COMPRESSOR START ASSIST								
CPLOWAMB001A00		Low Ambient Control – enables cooling system to operate down to 0 Deg. F by cycling condenser fan on and off.				ALL		
NRTIMEGD001A00		Five Minute Compressor Delay				ALL		
CPHSTART002A00		PTC Compressor Start Assist Kit				ALL		
CRANKCASE HEATERS (Factory installed on some models)								
CPCRKHTR008A00		Crankcase Heater (single-phase)				24-36		
CPCRKHTR004A00		Crankcase Heater (single-phase and 3-phase)				42-48		
ELECTRIC HEATER USAGE, 208/230-1-60								
Electric Heater Model Number	Nominal Capacity (kW)	Fuses	Used With PHR5 Model Sizes					
			24	30	36	42	48	60
CPHEATER052A0*	5.0	0	✓	✓	✓			
CPHEATER064A0*	5.0	4	✓	✓	✓	✓	✓	✓
CPHEATER069A0*	7.2	0	✓					
CPHEATER070A0*	7.2	4	✓	✓	✓	✓	✓	✓
CPHEATER050A0*	10.0	4	✓	✓	✓	✓	✓	✓
CPHEATER066A0*	15.0	6		✓	✓	✓	✓	✓
CPHEATER054A0*	20.0	6				✓	✓	✓
ELECTRIC HEATER USAGE, 208/230-3-60								
Electric Heater Model Number	Nominal Capacity (kW)	Fuses	Used With PHR5 Model Sizes					
			30	36	42	48	60	
CPHEATER055A0*	5.0	0	✓	✓	✓	✓		✓
CPHEATER056A0*	10.0	0	✓	✓	✓	✓		
CPHEATER068A0*	10.0	6	✓	✓	✓	✓		✓
CPHEATER058A0*	15.0	6	✓	✓	✓	✓		✓
CPHEATER059A0*	20.0	6			✓	✓		✓
DUCT TRANSITIONS								
NPDUFLG002A00		Square to Round (1 set of 2, use with horizontal duct flanges only)				24 – 48		
THERMOSTATS								
TSTAT0408		Universal Programmable Thermostat with Humidity Sensing and Control, Dual Fuel compatible, 2-stage cool, 2-stage gas heat, 2-stage HP heat, 2-stage electric heat.				ALL		
TSTAT0201CW		Observer Communicating Touchscreen Thermostat with Humidity Sensing and Control, Dual Fuel compatible, 2-stage cool, 2-stage gas heat, 2-stage HP heat, 2-stage electric heat. Requires Daughter Board				ALL		
NAXA00101DB		Daughter Board, use with communicating thermostat TSTAT0201CW and non-communicating equipment.				ALL		

