

# TECHNICAL DATA

## Recessed Fixtures

## RECESSED PAPER HOLDER - 9097

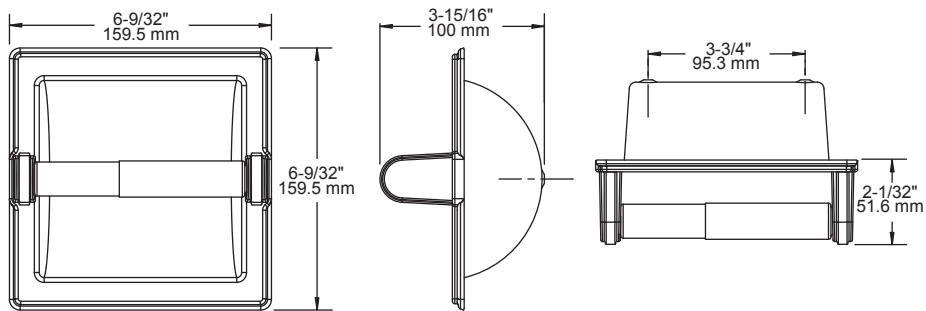

**MATERIALS:** Recessed Item - Stamping Brass, 20 Gauge  
Post - Zinc Die Cast  
Toilet Paper Holder - Stamping Brass

**INSTALLATION:** Cut a square hole in wall  $5\text{-}1/4\text{'}$  x  $5\text{-}1/4\text{'}$ . Fasten with wood screws provided into the wood backing or into studs.

**OPTIONAL FASTENER INFORMATION:** Wood blocking is preferable behind all wall surfaces. If wood blocking is not available, the following fasteners are suggested: Tile/Masonry - Plastic or Lead Anchors, Plaster/Drywall - Toggle Bolts.

**SPECIFICATION:** Recessed paper holder shall be model \_\_\_\_\_  
(fill in model number) by Liberty Hardware® Manufacturing Corporation.