

EPS10 Series Alarm Pressure Switches

Specifications

Contact Ratings:	10 A, 1/2 HP @ 125/250 VAC ~ 2.5A @ 6/12/24 VDC ---
Overall Dimensions:	See Figure 1
Operating Temperature Range:	-40° to +160°F
Maximum Service Pressure:	250 PSI
Maximum Adjustment Range:	4 - 20 PSI
Enclosure Rating:	UL 4x — Indoor or Outdoor Use NEMA 4 — Indoor or Outdoor Use IP54
Approximate Differential:	3 PSI throughout range

Important

Please Read Carefully and Save

This instruction manual contains important information about the installation and operation of alarm pressure switches. Purchasers who install switches for use by others must leave this manual or a copy of it with the user.

Read all instructions carefully before installation, following only those instructions that apply to the model you are installing.

Before installing any alarm device, be thoroughly familiar with:

- NFPA 72: *Installation, Maintenance, and Use of Protective Signaling Systems*
- NFPA 13: *Installation of Sprinkler Systems*
- NFPA 13A: *Inspection, Testing, and Maintenance of Sprinkler Systems*

Other applicable NFPA standards, local codes, and the requirements of the authority having jurisdiction.

Failure to follow these directions may result in failure of the device to report an alarm condition. System Sensor is not responsible for devices that have been improperly installed, tested, or maintained.



**Do not use in potentially explosive atmospheres.
 Do not leave unused wires exposed.**

Operation

As pressure changes, a diaphragm actuates 1 or 2 snap action switches. The pressure switch actuation is determined by adjustment settings.

Installation

1. Remove Cover
Cover is held on by two tamper resistant screws. (Removal key is enclosed with pressure switch.)
2. Mounting the Switch
The device is designed to be mounted in the upright or horizontal position; side mounting is also acceptable. Locate it where vibration, shock, and mechanical loading are minimal. Refer to piping diagram (Figure 2 on page 2).

Figure 1. Pressure switch basic dimensions:

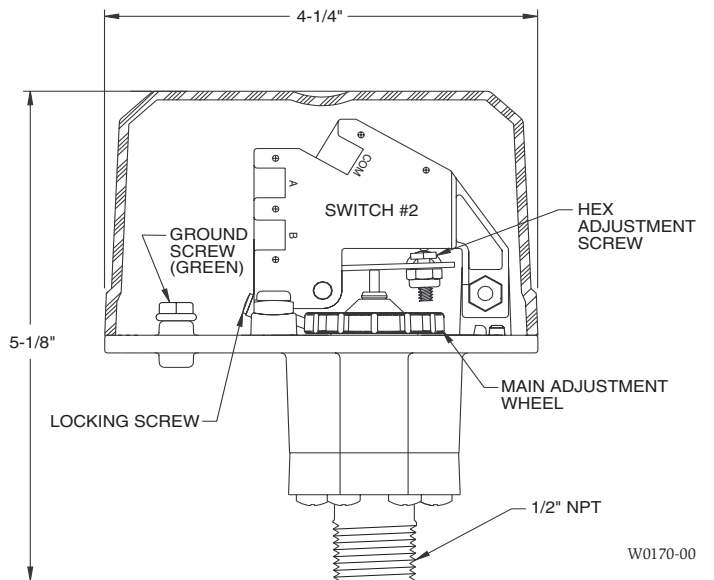
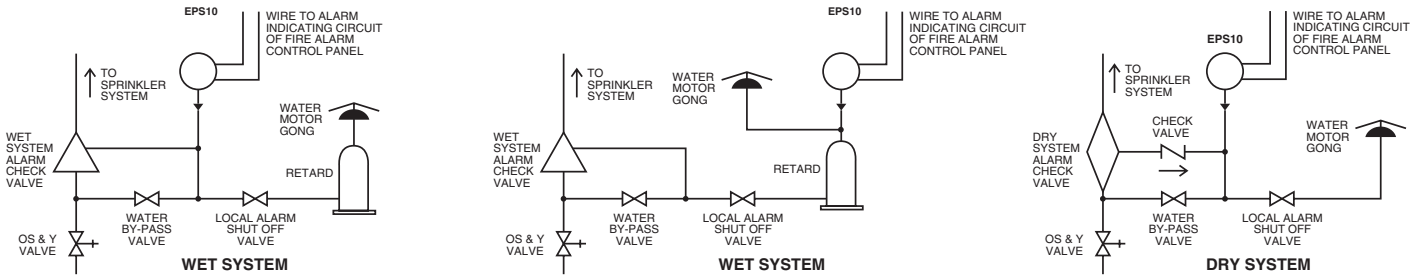

Figure 2. Typical piping diagram for EPS10-1, EPS10-2



W0171-01

- a. Mount the device directly to the line via the 1/2" NPT pressure connection. The use of teflon pipe sealant tape is recommended. Be sure the fitting is tight enough to prevent leaks.
- b. Apply tightening torque to the black plastic hex portion of device.



High voltage. Electrocutation hazard. Do not handle live AC wiring or work on a device to which AC power is applied. Doing so may result in severe injury or death. When utilizing switches at voltages greater than 74 VDC --- or 49 VAC ~ , means to provide all-pole disconnection must be incorporated in the field wiring, such as a circuit breaker.

3. Wire the device in accordance with the National Electrical Code. Two 7/8" diameter conduit connection holes have been provided in the mounting plate to accept standard 1/2" conduit fittings (one is removable knock-out type). If a NEMA 4/UL 4x (waterproof unit) is required, waterproof flexible metallic conduit and appropriate conduit fittings must be used. Recommended connectors are Thomas and Betts PN 5332 (180° coupling), PN 5352 (90° coupling), and PN 5262 seal ring.
4. Connect wiring to terminals (see Figure 3 and Table 1).

Table 1. Electrical connections (referenced at factory settings):

MODEL EPS10-1	MODEL EPS10-2
SWITCH AT 0 P.S.I.	SWITCHES AT 0 P.S.I.
SWITCH AT 4-8 P.S.I. (HIGH TRIP PT.)	SWITCHES AT 4-8 P.S.I. (HIGH TRIP PT.)
SWITCH 1	BOTH SWITCHES ACTIVATE SIMULTANEOUSLY

Figure 3. Switch terminals:

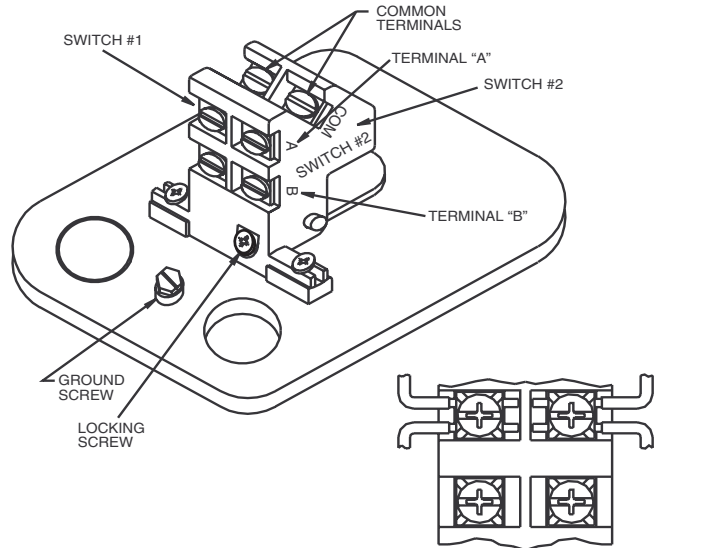

BREAK WIRE AS SHOWN FOR SUPERVISION OF CONNECTION. DO NOT ALLOW STRIPPED WIRE LEADS TO EXTEND BEYOND SWITCH HOUSING. DO NOT LOOP WIRES.

W0173-00

Adjustments To Factory Settings

Both EPS10-1 and EPS10-2 devices are pre-adjusted at the factory to alarm at 4–8 PSI on rising pressure (see Table 2). Pressure switch settings may be adjusted in the field to obtain a different pressure alarm response from 4 PSI to 20 PSI. The switch has an override feature on the adjustment mechanism to prevent exceeding the 20 PSI max. setting of the switch. This override feature carries with it a tolerance band that may limit the upper adjustment to 16–20 PSI. Care must be used when setting the switch to ensure that the lower limit of 4 PSI is not exceeded. This will allow the switch to reset within the 3 PSI differential stated.

1. Install pressure switch as stated in “INSTALLATION” portion of instruction manual. Attach pressure test source to system.
2. Back off locking screw (see Figure 1) to allow main adjustment wheel to rotate freely.
3. Test trip point by slowly introducing pressure from the pressure test source. When trip point is found, reduce pressure to zero. Rotate main adjustment wheel (counterclockwise to increase pressure) and retest until switch trip point is at the desired pressure setting (4–20 PSI range). Each number represents an approximate trip point change of 0.2 PSI. One full rotation changes the trip point setting by approximately 2.5 PSI. A reset differential of approximately 3 PSI is typical throughout the entire adjustment range of switch.
4. Retest the set point several times to ensure accuracy of setting.
5. Re-seat locking screw.

Table 2.

MODEL	Factory Settings (PSI)			
	Fall (Low Switch)	Approx. Reset	Rise (High Switch)	Approx. Reset
EPS10-1	—	—	4– 8	3 PSI diff.
EPS10-2	—	—	4– 8	3 PSI diff.

NOTE: The sensor assembly is not field replaceable. Do not attempt to disassemble these parts. If you have any questions, consult System Sensor. System Sensor recommends careful consideration of the following factors when specifying and installing Alarm Pressure Switches. Always refer to the Installation and Maintenance Instruction for specific recommendations on individual devices before installing the unit.

- Electrical ratings stated in literature and on nameplates should not be exceeded.
- Overload on switch can cause failure on the first cycle. Always wire devices according to national and local electrical codes.
- Install units away from shock and vibration. Proper electrical fittings should be used to prevent moisture from entering the enclosure via the conduit.
- Test all devices for proper operation after initial installation. Perform preventive maintenance and periodic testing as required by the applicable NFPA standards but not less than bi-monthly.
- Install a back-up control for all critical applications where control failure could endanger life or property. A backup control to serve as a high or low limit control is especially recommended for applications where a runaway condition could result.
- Do not mount unit where ambient temperatures will exceed published limits.
- Avoid impact or mechanical loading.

Please refer to insert for the Limitations of Fire Alarm Systems

Three-Year Limited Warranty

System Sensor warrants its enclosed pressure switch to be free from defects in materials and workmanship under normal use and service for a period of three years from date of manufacture. System Sensor makes no other express warranty for this pressure switch. No agent, representative, dealer, or employee of the Company has the authority to increase or alter the obligations or limitations of this Warranty. The Company's obligation of this Warranty shall be limited to the repair or replacement of any part of the pressure switch which is found to be defective in materials or workmanship under normal use and service during the three year period commencing with the date of manufacture. After phoning System Sensor's toll free number 800-SENSOR2 (736-7672) for a Return Authorization number, send defective units postage prepaid to: System Sensor, Return

Department, RA #_____, 3825 Ohio Avenue, St. Charles, IL 60174. Please include a note describing the malfunction and suspected cause of failure. The Company shall not be obligated to repair or replace units which are found to be defective because of damage, unreasonable use, modifications, or alterations occurring after the date of manufacture. In no case shall the Company be liable for any consequential or incidental damages for breach of this or any other Warranty, expressed or implied whatsoever, even if the loss or damage is caused by the Company's negligence or fault. Some states do not allow the exclusion or limitation of incidental or consequential damages, so the above limitation or exclusion may not apply to you. This Warranty gives you specific legal rights, and you may also have other rights which vary from state to state.