



# SERVICE PARTS LIST

**BULLETIN NO.**  
**54-49-3115**

SPECIFY CATALOG NO. AND SERIAL NO. WHEN ORDERING PARTS		REVISED BULLETIN	DATE
<b>FASTBACK™ FLIP POCKET KNIFE</b>			Dec. 2012
<b>CATALOG NO.</b> 48-22-1901	SERIAL NUMBER	WIRING INSTRUCTION	

**EXAMPLE:**  
Component Parts (Small #) Are Included  
When Ordering The Assembly (Large #).

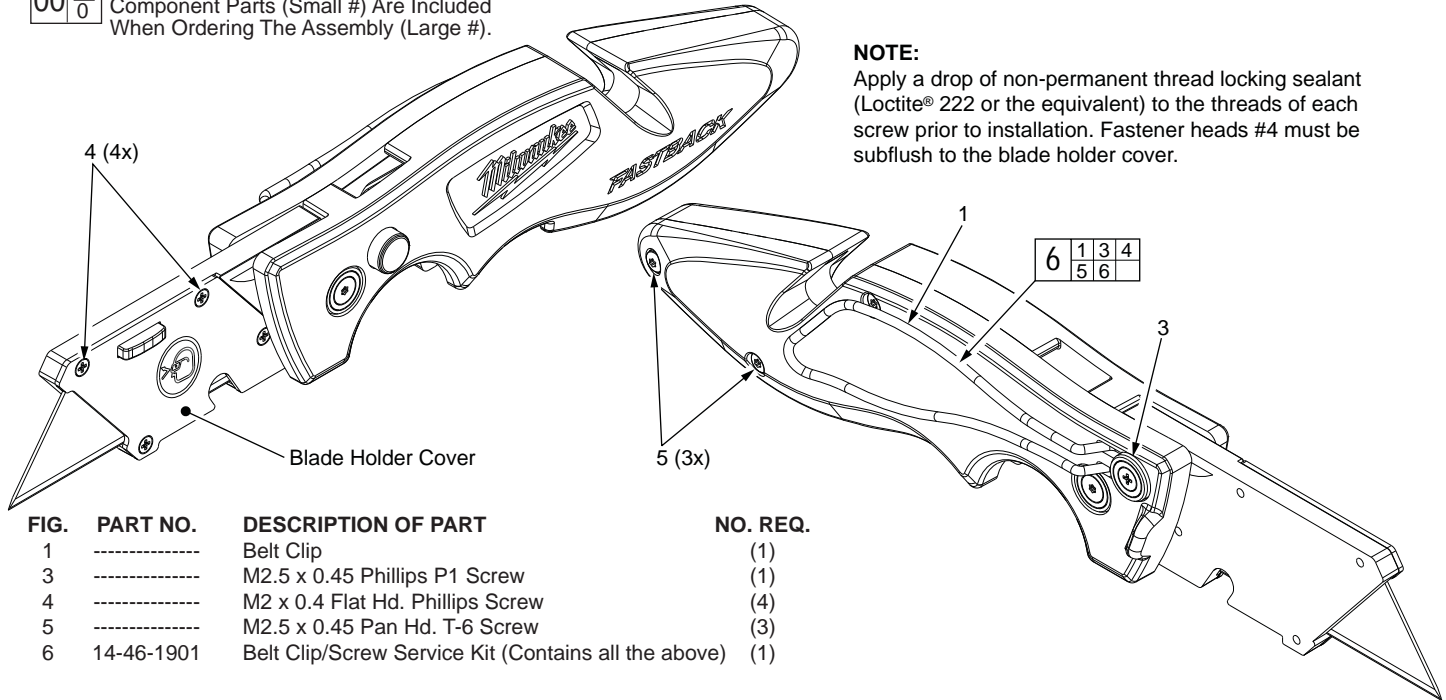

**NOTE:**  
Apply a drop of non-permanent thread locking sealant (Loctite® 222 or the equivalent) to the threads of each screw prior to installation. Fastener heads #4 must be subflush to the blade holder cover.

FIG.	PART NO.	DESCRIPTION OF PART	NO. REQ.
1	-----	Belt Clip	(1)
3	-----	M2.5 x 0.45 Phillips P1 Screw	(1)
4	-----	M2 x 0.4 Flat Hd. Phillips Screw	(4)
5	-----	M2.5 x 0.45 Pan Hd. T-6 Screw	(3)
6	14-46-1901	Belt Clip/Screw Service Kit (Contains all the above)	(1)

SPECIFY CATALOG NO. AND SERIAL NO. WHEN ORDERING PARTS		REVISED BULLETIN	DATE
<b>FASTBACK II™ FLIP POCKET KNIFE</b>			
<b>CATALOG NO.</b> 48-22-1902	SERIAL NUMBER	WIRING INSTRUCTION	

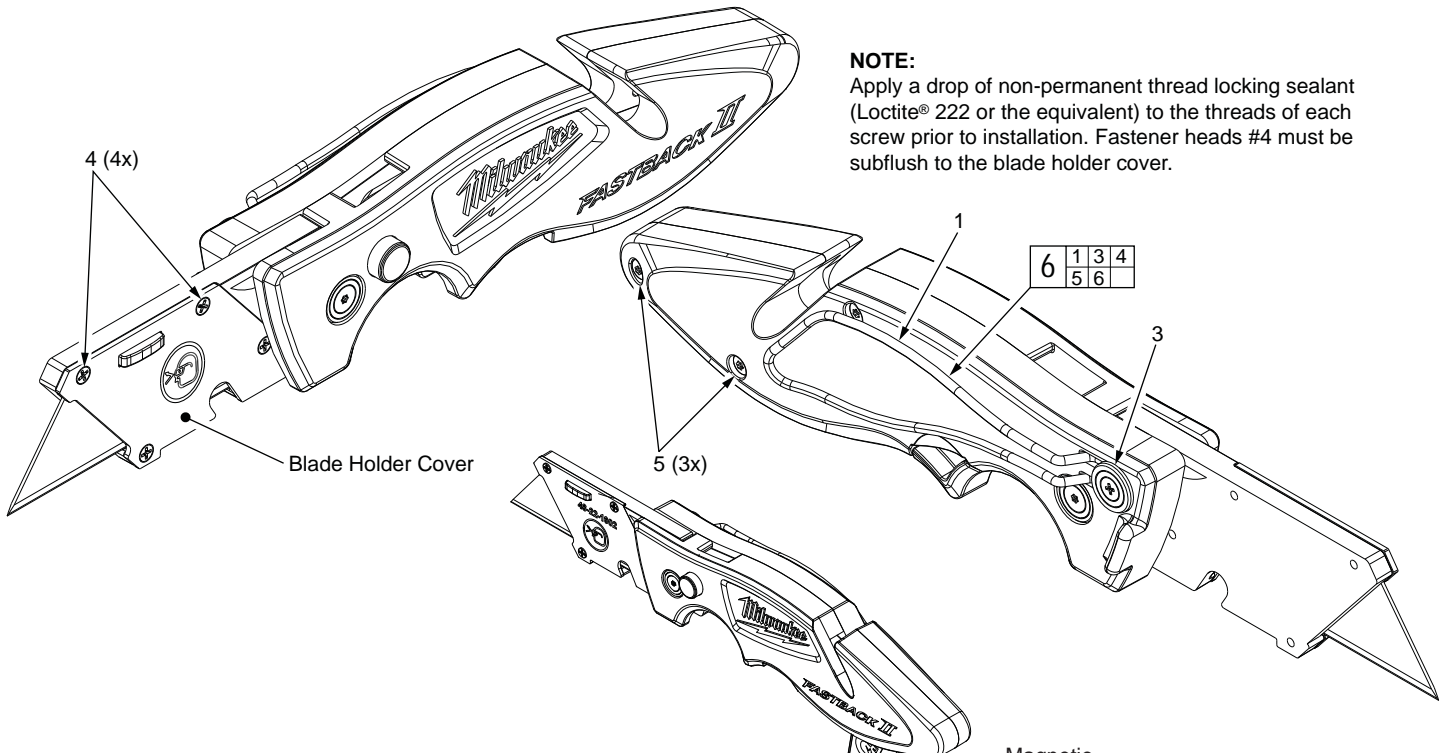

**NOTE:**  
Apply a drop of non-permanent thread locking sealant (Loctite® 222 or the equivalent) to the threads of each screw prior to installation. Fastener heads #4 must be subflush to the blade holder cover.

FIG.	PART NO.	DESCRIPTION OF PART	NO. REQ.
1	-----	Belt Clip	(1)
3	-----	M2.5 x 0.45 Phillips P1 Screw	(1)
4	-----	M2 x 0.4 Flat Hd. Phillips Screw	(4)
5	-----	M2.5 x 0.45 Pan Hd. T-6 Screw	(3)
6	14-46-1901	Belt Clip/Screw Service Kit (Contains all the above)	(1)

Magnetic  
Blade Storage Door

**MILWAUKEE ELECTRIC TOOL CORPORATION**  
13135 W. LISBON RD., BROOKFIELD, WI 53005  
Drwg. 4