

Axiom AMI by StoneL

Installation, Maintenance and
Operating instructions

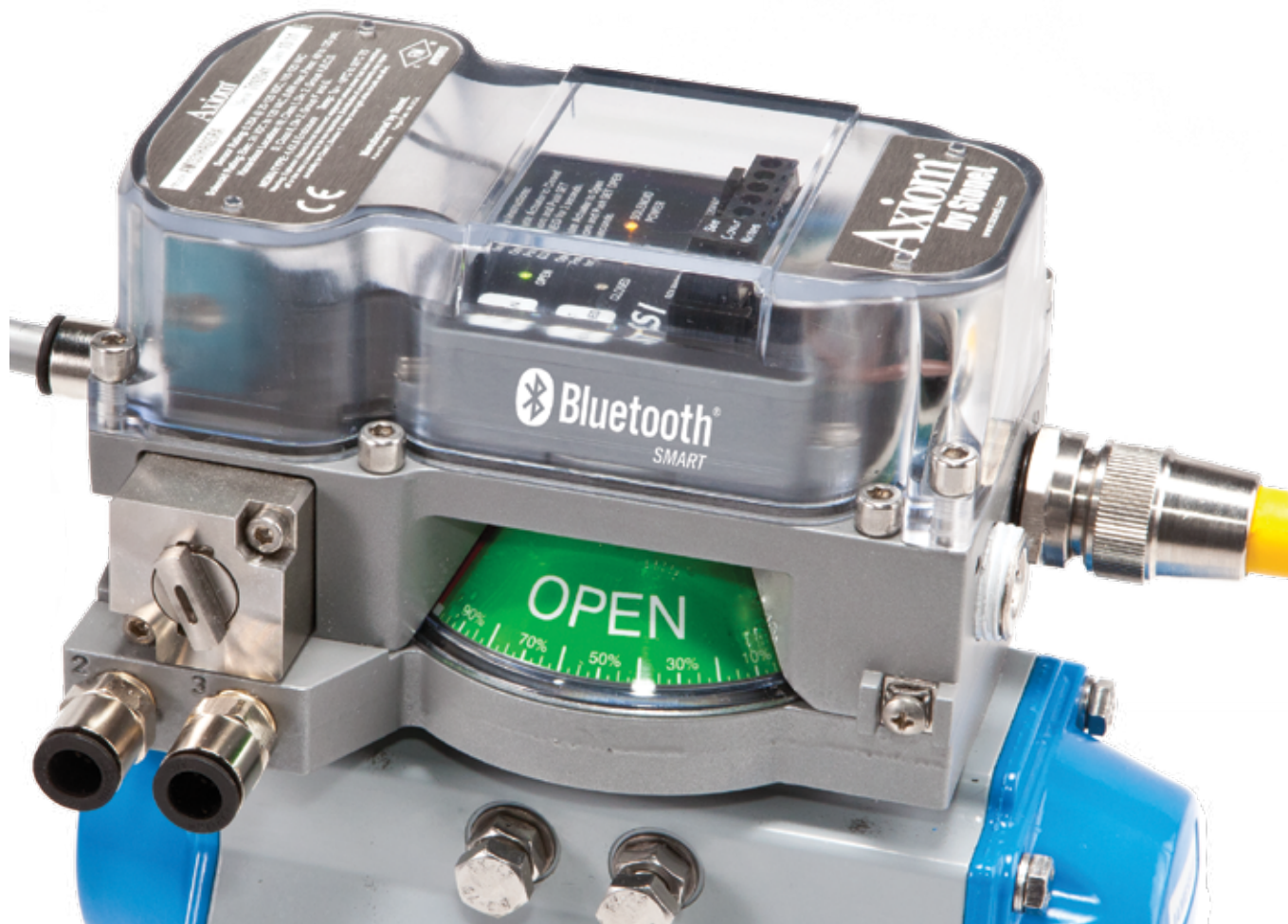

Table of contents

| | |
|--|----|
| 1 General | 3 |
| 1.1 Introduction | 3 |
| 1.2 Title plate markings | 3 |
| 1.3 CE markings | 3 |
| 1.4 Recycling and disposal | 3 |
| 1.5 Safety precautions | 3 |
| 1.6 Assembly drawing | 4 |
| 1.7 Specifications for all models | 4 |
| 1.8 Pneumatic valve specifications | 5 |
| 1.9 Pneumatic valve schematics | 5 |
| 1.10 Dimensions | 6 |
| 2 Assembly and mounting | 7 |
| 2.1 Instructions | 7 |
| 2.2 Axiom AMI assembly figure | 8 |
| 3 Maintenance, repair and installation | 9 |
| 3.1 Maintenance and repair | 9 |
| 3.2 Installation | 9 |
| 3.3 Special conditions of use | 9 |
| 4 Function specific details | 10 |
| 4.1 Sensor/switching modules | 10 |
| 4.1.1 SST N.O. sensor (33) | 10 |
| 4.1.2 SST N.O. sensor; 240 VAC (35) | 12 |
| 4.1.3 NAMUR sensor (44) | 14 |
| 4.1.4 Expeditor (80) | 16 |
| 4.2 Valve communication terminals (VCT) | 19 |
| 4.2.1 VCT with HART diagnostics (71D) | 19 |
| 4.2.2 VCT with DeviceNet™ communication (92S) | 24 |
| 4.2.3 VCT with Foundation Fieldbus communication (93S) | 26 |
| 4.2.4 VCT with Foundation Fieldbus communication with externally powered outputs (94S) | 27 |
| 4.2.5 VCT with AS-Interface communication (96S) | 28 |
| 4.2.6 VCT with AS-Interface communication with diagnostics (96D) | 29 |
| 4.2.7 VCT with AS-Interface communication and extended addressing (97S) | 31 |
| 4.2.8 VCT with AS-Interface with Wireless Link (96W & 97W) | 32 |
| 5 Wireless Link user guide | 34 |
| 5.1 Getting started | 34 |
| 5.2 Home screen | 34 |
| 5.3 Locked screen | 34 |
| 5.4 Device detail screen | 35 |
| 5.5 More information screen | 36 |
| 5.6 Diagnostics screen | 36 |
| 5.7 Federal Communication Commission (FCC) statement | 37 |
| 6 Model/Type code | 39 |
| 7 Regulatory, specific conditions of use, and product marking | 40 |
| 8 Appendix | 42 |
| 8.1 Controlled installation drawings | 42 |

Read these instructions first!

These instructions provide information about safe handling and operation of the Axiom AMI by StoneL. If you require additional assistance, please contact the manufacturer or manufacturer's representative. Addresses and phone numbers are printed on the back cover.

Save these instructions.

Subject to change without notice.

All trademarks are property of their respective owners.

1 General

1.1 Introduction

This manual incorporates the Installation, Maintenance and Operation (IMO) instructions for the Axiom AMI series valve controllers. The Axiom AMI is designed to provide position feedback indication and pneumatic control of on/off automated valves.

Note

The selection and use of the Axiom AMI in a specific application requires close consideration of detailed aspects. Due to the nature of the product, this manual cannot cover all the likely situations that may occur when installing, using, or servicing the Axiom AMI. If you are uncertain about the use of this device, or its suitability for your intended use, please contact StoneL for assistance.

1.2 Title plate markings

The limit switch has an identification plate attached to the cover.

1. Identification plate markings:
2. Model
3. Serial number
4. Date
5. Electrical rating(s)
6. Protection class information*
7. Note
8. Warning
9. Approval marking*
10. Logo

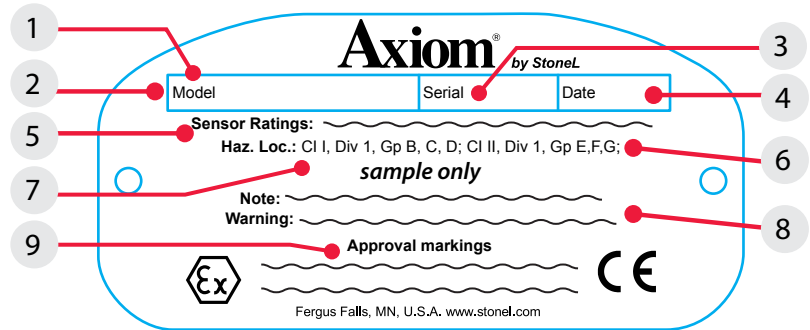

Note

* See page 38 for specific product markings.

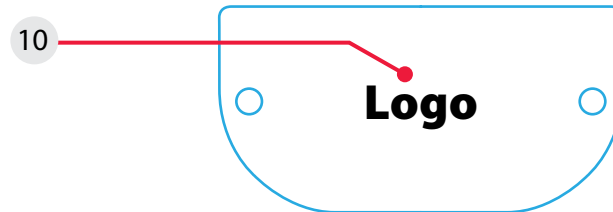

1.3 CE markings

The Axiom AMI meets the requirements of European Directives and has been marked according to the directive.

1.4 Recycling and disposal

Most Axiom AMI parts can be recycled if sorted according to material. In addition, separate recycling and disposal instructions are available from us. A limit switch can also be returned to us for recycling and disposal for a fee.

1.5 Safety precautions

Do not exceed the permitted values! Exceeding the permitted values marked on the Axiom AMI may cause damage to the switch and to equipment attached to the switch and could lead to uncontrolled pressure release in the worst case. Damage to the equipment and personal injury may result.

To prevent ignition of hazardous atmospheres, replace cover before energizing the electrical circuits. Keep cover tightly closed when in operation.

1.6 Assembly drawing

- | | |
|---|--|
| 1. Title plate | 11. Visual indicator drum |
| 2. Cover screws | 12. Visual indicator drum coupler |
| 3. Cover | 13. Visual indicator drive block |
| 4. Body screws | 14. Air manifold plate mounting screws |
| 5. Body | 15. Air manifold plate orifice o-rings |
| 6. Internal ground lug | 16. Visual indicator cover o-ring |
| 7. External ground lug | 17. Air manifold plate |
| 8. DA/SR plug | 18. Actuator shaft |
| 9. Visual indicator cover | |
| 10. Visual indicator drum retaining screw | |

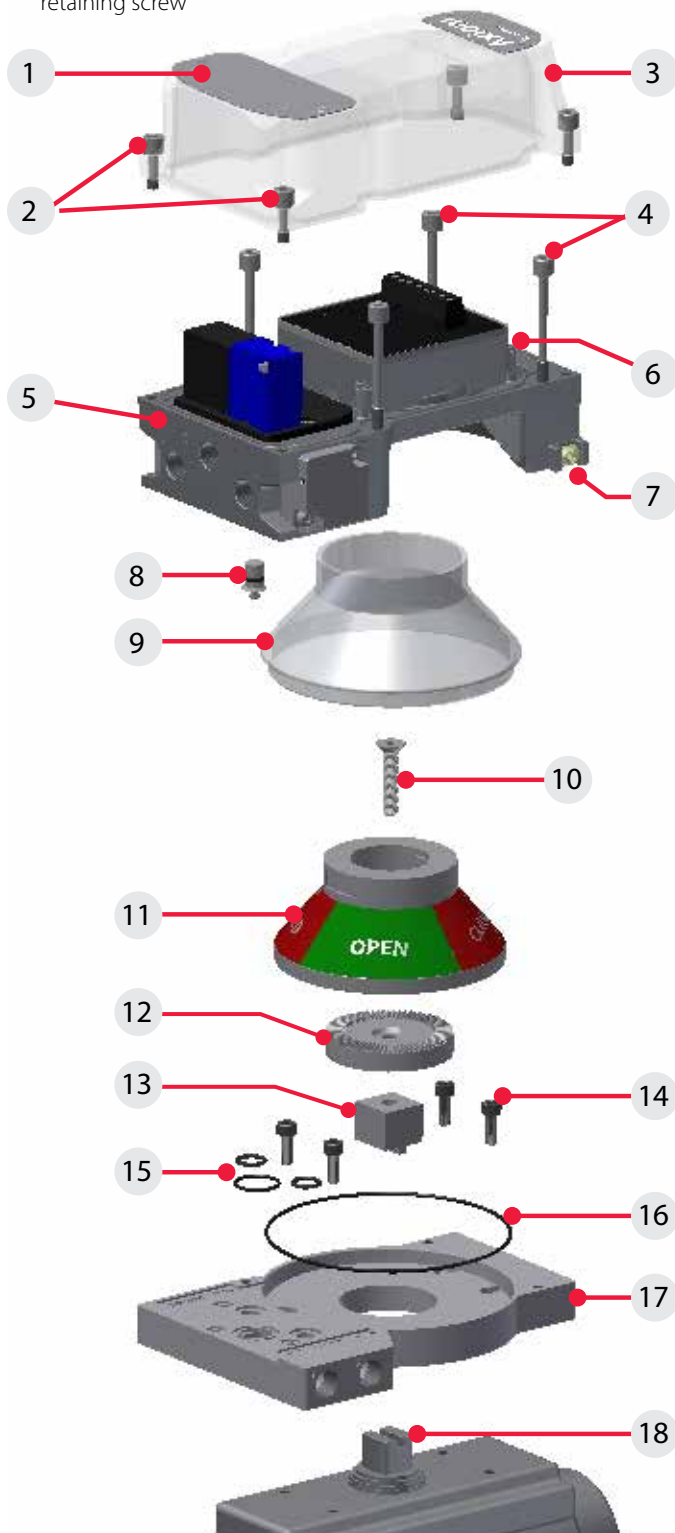

1.7 Specifications for all models

See page 10 for function specific details.

| Specifications | |
|--|--|
| Materials of construction | |
| Cover | Lexan® polycarbonate and Aluminum |
| Housing & air manifold plate | Epoxy-coated anodized aluminum |
| Visual indicator drum | Polysulfone |
| Visual indicator cover | Polycarbonate |
| Fasteners | Stainless steel |
| O-rings | Nitrile compound |
| Operating life | 1 million cycles (500,000 cycles for the Expeditor) |
| Temperature range | See 1.8 Pneumatic valve specifications |
| Enclosure protection | |
| Type 4, 4X, and 6 and IP67 | |
| Warranty | |
| Sensing & communication module | Five years |
| Mechanical components | Two years |
| Unit weights | |
| Aluminum | 2.48 kg / 5.45 lb |
| Unit dimensions | |
| Unit height | 98.43 mm [3.87 in] |
| Cover removal clearance | 148.63 mm [5.87 in] |
| Position sensing | |
| Accuracy | Within 1° |
| Repeatability | Within 1° |
| Setting buffer | 4° from setpoint (<i>Rotational distance from original setpoint where switch will energize on return stroke</i>) |
| Dead band | 6° from setpoint (<i>Rotational distance from original setpoint where switch will de-energize</i>) |
| Max rotational range | 120° |
| Ratings and approvals* | |
| See page 38 or Stonel.com/approvals | |

* Only models listed on Stonel's official website are approved per specific rating.

1.8 Pneumatic valve specifications

| Specifications | |
|---|---|
| General pneumatic specifications | |
| Valve design | Pilot operated spool valve |
| Pilot operator options | Solenoid coil or Piezo |
| Configuration | Single pilot 5-way, 2-position, spring return Dual pilot 5-way, 2-position, shuttle piston |
| Flow rating | 0.70 Cv (Kv = 0.60 based on flow m3/hr) |
| Axiom porting | ¼" NPT |
| Manifold porting | ¼" NPT |
| Operating pressure | 40 psi to 120 psi (2.7 to 7.5 bar) |
| Operating temperature | Standard temp coil -18° C to 50° C (0° F to 122° F) Extended temp coil -40° C to 80° C (-40° F to 176° F) |
| Operating life | 1 million cycles (500,000 cycles for the Expeditor) |
| Manual override | Internal momentary Optional external momentary available Optional external latching available |
| Material of construction | |
| Spool | Nickel plated aluminum |
| Body | Epoxy-coated anodized aluminum |
| Seal spacers | Polysulfone |
| Spool seals | Nitrile compound |
| O-rings | Nitrile compound |
| End caps and fasteners | Stainless steel |
| Solenoid coil specifications | |
| 24 VDC/ 120 VAC Universal (1H, 2H, 3H, 4H, 5H, 6H) | |
| Operating voltage minimum | 22 VDC |
| Operating voltage maximum | 130 VAC |
| Power consumption | 0.6 watts |
| AC current consumption | 18 mA |
| Filtration requirements | 40 microns |
| 24 VDC (1B, 2B, 3B, 4B, 5B, 6B) | |
| Operating voltage | 24 VDC |
| Power consumption | 1.8 watts |
| Filtration requirements | 40 microns |
| 24 VDC (1D, 2D, 3D, 4D, 5D, 6D) | |
| Operating voltage | 24 VDC |
| Power consumption | 0.5 Watts |
| Filtration requirements | 40 microns |
| 12 VDC (1E, 2E, 3E, 4E, 5E, 6E) (Intrinsically Safe) | |
| Operating voltage | 12 VDC (output of barrier) |
| Power consumption | 0.5 watts |
| Filtration requirements | 40 microns |
| Entity parameters | Ui=28VDC; li=120mA; Ci=0; Li=0; Pi=1.0W |
| Piezo (1A, 2A, 3A, 4A, 5A, 6A) | |
| Operating voltage | 5.5 - 9.0 VDC |
| Current consumption | 2.0 mA @ 6.5 VDC |
| Temperature range | -10° C to 60° C (14° F to 140° F) |
| Filtration requirements | Dried/30 microns |

1.9 Pneumatic valve schematics

Fig. 1 Single pilot spring return pneumatic valve on spring return actuator with rebreather open

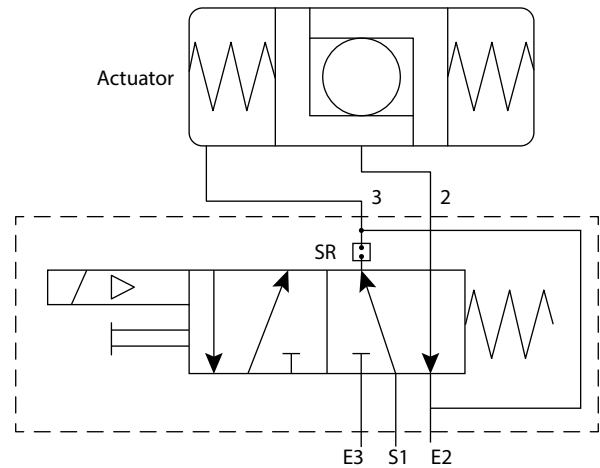

Fig. 2 Single pilot spring return pneumatic valve on double-acting actuator with rebreather closed

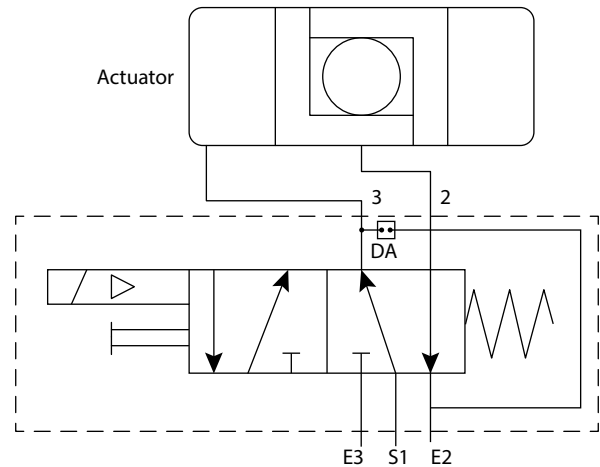
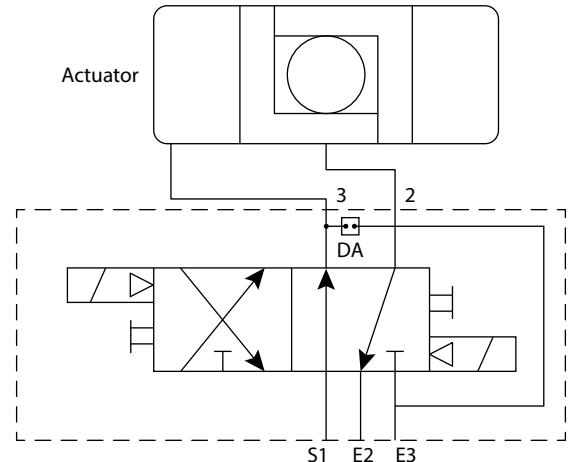

Fig. 3 Axiom dual coil shuttle piston pneumatic valve



Note

Pneumatic valve schematics unique to AX80S functions are on page 18 as Fig. 4 and Fig. 5 with additional information.

1.10 Dimensions

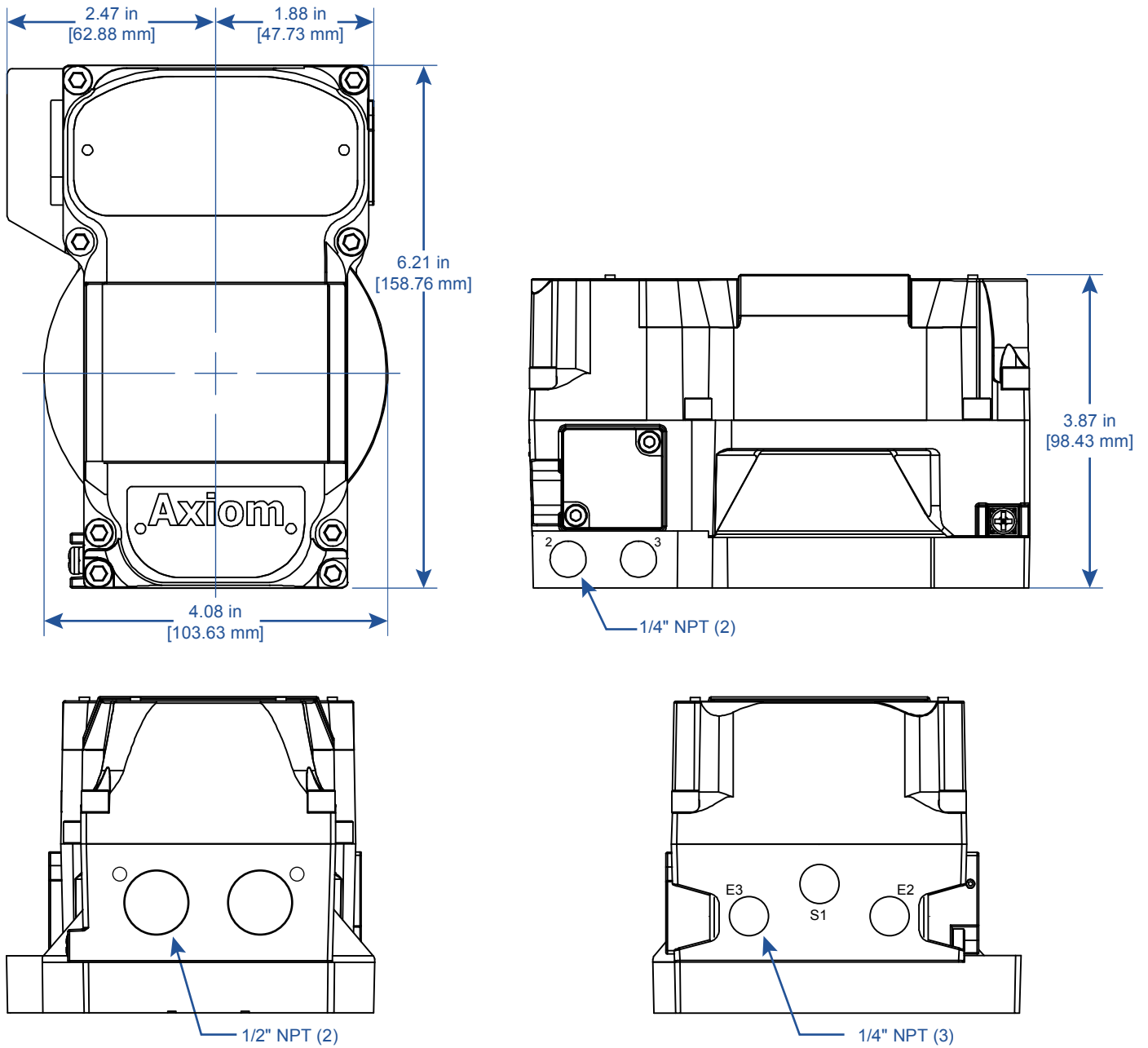

Note

Axiom AMI certified dimensional drawing can be found under the Download tab at www.stonel.com/en/products/axiom_AMI/

2 Assembly and mounting

2.1 Instructions

Special notes:

- Mounting of the Axiom requires a StoneL mounting kit specific to the actuator the Axiom is to be mounted to.
- It is recommended that thread lubricant or anti-seize be used on the Axiom body screws (Item C) prior to assembly.
- In high cycle or high vibration applications, blue Loctite® may be used on the air manifold mounting screws (Item I) and the visual indicator drum retaining screw (Item E).
- It is highly recommended that exhaust ports E2 and E3 be fitted with low restriction mufflers or breather vent caps to prevent ingestion of water and debris into the pneumatic valve.

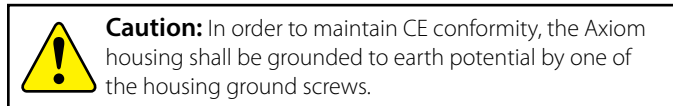

Steps

Refer to Axiom AMI assembly figure on page 8 when performing mounting and assembly procedures. Axiom unit and mounting kit are supplied separately. From Axiom shipping container, ensure items A, D, F, and G are present. From the mounting kit, ensure items E, H, I, J, and K are present.

1. Determine if the actuator the Axiom is to be mounted on is double-acting (DA) or spring return (SR). Ensure the DA/SR plug (Item D) is in the corresponding port in bottom of the Axiom body. (See detailed view from bottom of A). If the DA/SR plug is in the incorrect position, gently remove plug with a pair of pliers and insert into the proper orifice.
2. Locate the air manifold plate (Item K). Place the air manifold plate on the actuator. Using an M4 allen wrench, fasten with the four air manifold mounting screws (Item I). Torque screws to 25 to 30 in.lbs (2.8 to 3.4 Nm).
3. Place visual indicator drive block (Item H) into slot on the actuator shaft. Place visual indicator drum coupler (Item G) onto the visual indicator drive block. Next, place the visual indicator drum (Item F) onto the visual indicator drum coupler. Align the holes in all three items with the threaded hole in the actuator shaft and fasten down with the visual indicator drum retaining screw (Item E). Leave screw loose in order to facilitate indexing of the visual indicator.
4. With the actuator in the closed position, center the visual indicator drum until the OPEN quadrant is centered between the V.I. INDEX marking on the air manifold plate. (See detailed view of K). With M4 allen wrench, tighten down with the visual indicator drum retaining screw 15 to 20 in.lbs (1.7 to 2.3 Nm).
5. Verify air manifold plate orifice o-rings and visual indicator cover o-ring (Item J) are in place.
6. Set the Axiom body (Item A) in place. With an M4 allen wrench, torque the Axiom body screws (Item C) to 25 to 30 in. lbs (2.8 to 3.4 Nm).
7. After all wiring and sensor setting procedures have been completed, install Axiom cover and tighten the Axiom cover screws (Item B) with M4 allen wrench to 15 to 20 in.lbs (1.7 to 2.3 Nm) .

Detailed view from bottom of A

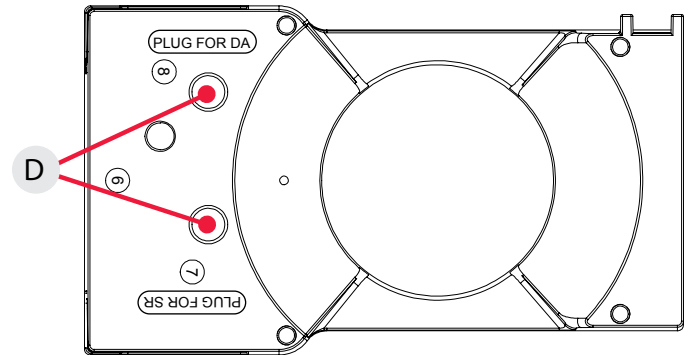

Detailed view of K

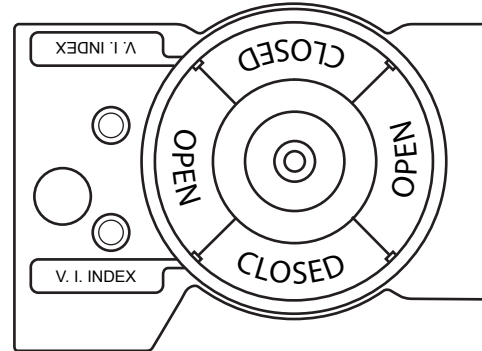

2.2 Axiom AMI assembly figure

- A. Axiom AMI unit
- B. Cover screws (4)
- C. Body screws (4)
- D. DA/SR plug
- E. Visual indicator drum retaining screw
- F. Visual indicator drum
- G. Visual indicator drum coupler
- H. Visual indicator drive block
- I. Air manifold plate mounting screws
- J. Air manifold plate orifice o-rings and Visual indicator cover o-ring
- K. Air manifold plate

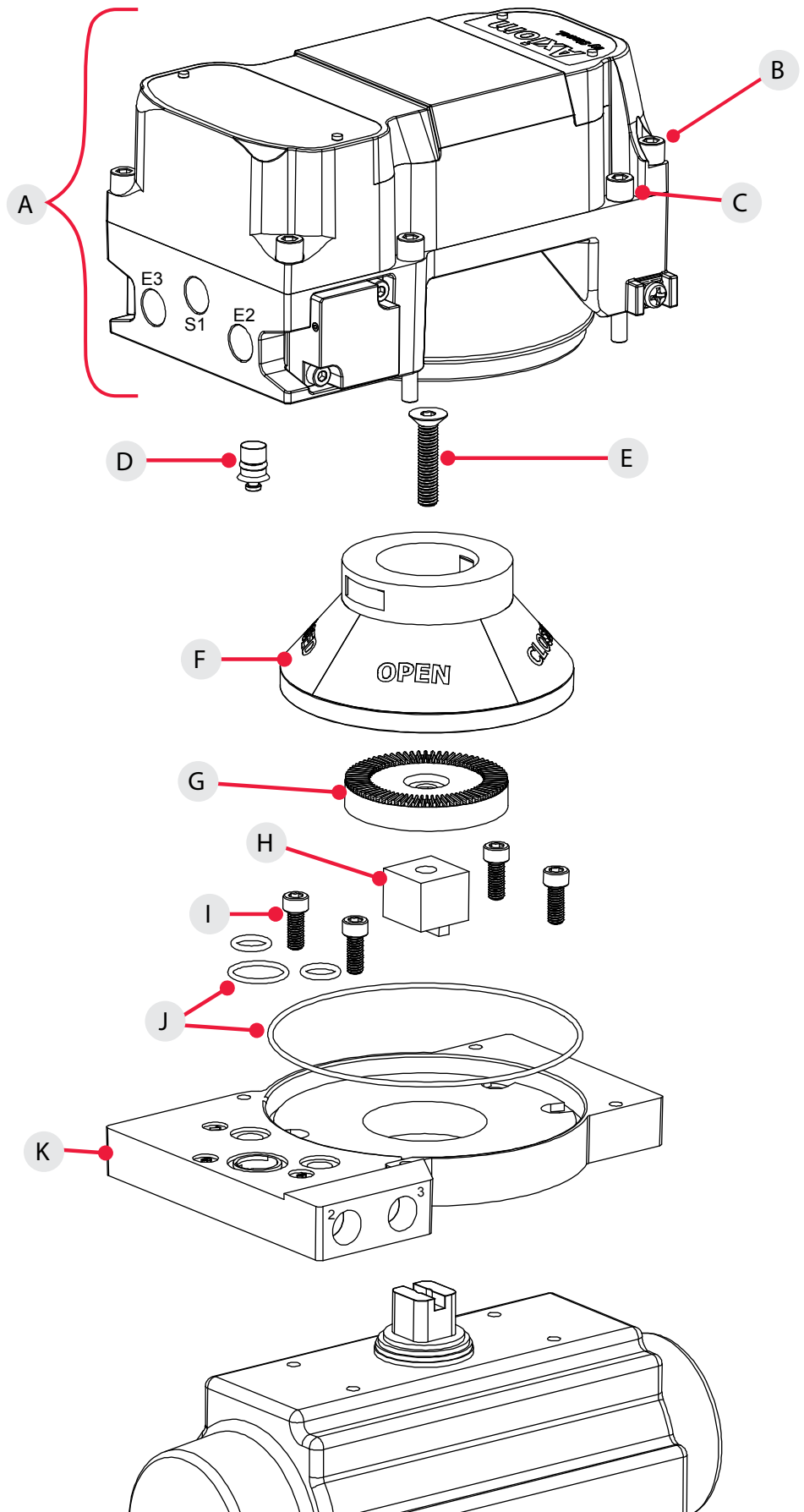

3 Maintenance, repair and installation

3.1 Maintenance and repair

No routine maintenance of Axiom units is required when installed in environments for which they are designed. If installed in severe environments, pneumatic components may require replacement at more frequent intervals for maximum performance. Repair of Axiom units must be done by StoneL or by qualified personnel that are knowledgeable about the installation of electromechanical equipment in hazardous areas. All parts needed for repair must be purchased through a StoneL authorized distributor to maintain warranty and to ensure the safety and compliance of the equipment.

3.2 Installation

WARNING

Solenoid power supplied must be limited with a fuse or circuit breaker rated to 2 Amps maximum.



Attention: If required, the Axiom housing can be grounded to earth potential by either the internal or external ground lug. (See Assembly drawing 1.6 items 6 and 7 on page 4)

Field wiring

- It is the responsibility of the installer, or end user, to install this product in accordance with the National Electrical Code (NFPA 70) or any other national or regional code defining proper practices.
- This product comes shipped with conduit covers in an effort to protect the internal components from debris during shipment and handling. It is the responsibility of the receiving and/or installing personnel to provide appropriate permanent sealing devices to prevent the intrusion of debris or moisture when stored or installed outdoors.
- When installed in ambient temperatures over 60° C, use field wiring rated for 90° C.

3.3 Special conditions of use

For units with quick connect receptacles, when installed in Division 2 areas, an appropriate FM approved mating cord must be used in conjunction with tamper proof guard at the mating point that requires a tool to remove, rendering the connection not normally arcing.

4 Function specific details

4.1 Sensor/switching modules

4.1.1 SST N.O. sensor (33)

| Specifications | |
|-------------------------|--|
| Configuration | (2) N.O. 2-wire solid state sensors |
| Voltage range | 22 - 130 VDC/VAC |
| Maximum current | Continuous 0.1 amps |
| Minimum on current | 2.0 mA |
| Maximum leakage current | 0.5 mA |
| Maximum voltage drop | 6.5 volts @ 10 mA 7.0 volts @ 100 mA |
| Circuit protection | Protected against short circuits and direct application of voltage with no load. |

WARNING

Do not apply external power to the SOL OUT terminals. This will cause permanent damage to the unit.

Bench test procedure and sensor setting instructions

Power must be applied to both sensors to ensure proper circuit operation. Use a 24 VDC power supply with series load resistor, (2K - 6K Ω), connected to the 24 VDC+.

1. Connect 24 VDC+ to the CLOSED C (common) and OPEN C (common) terminals. Connect 24 VDC- to the CLOSED NO and OPEN NO terminals.
 2. Operate actuator to the closed position.
 3. Press and hold SET CLOSED button until CLOSED LED is lit (2 seconds). Release button.
 4. Operate actuator to the open position.
 5. Press and hold SET OPEN button until OPEN LED is lit (2 seconds). Release button.
 6. Setpoints are retained even after power is removed.
- To electrically test solenoid, apply power to the SOL PWR IN terminals only.

Note

If using only one of the sensors for valve position feedback, the open sensor (green) must be used.

Caution: A series load resistor must be used when bench testing in order to prevent permanent damage to the unit.

Wiring diagrams

Single coil solenoid

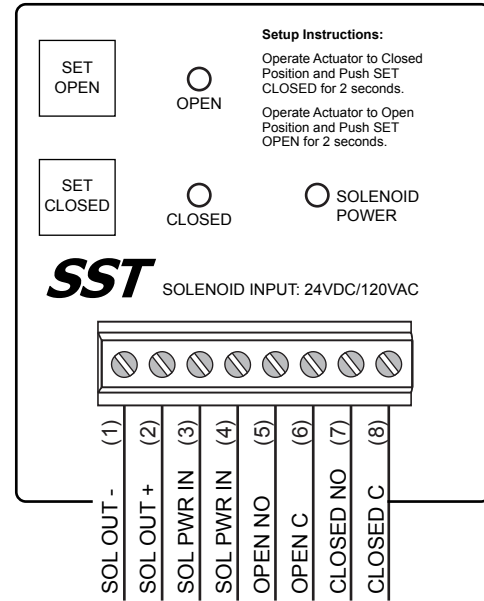

Common receptacle options pin-out

5-PIN MICRO CONNECTOR (M12)

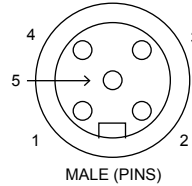

5-PIN MINI CONNECTOR

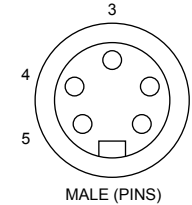

| Pin | Signal |
|-----|---------------|
| 1 | OPEN/CLOSED C |
| 2 | CLOSED NO |
| 3 | OPEN NO |
| 4 | SOL PWR IN + |
| 5 | SOL PWR IN - |

4.1.1 SST N.O. sensor (33) continued

Wiring diagrams

Dual coil solenoid

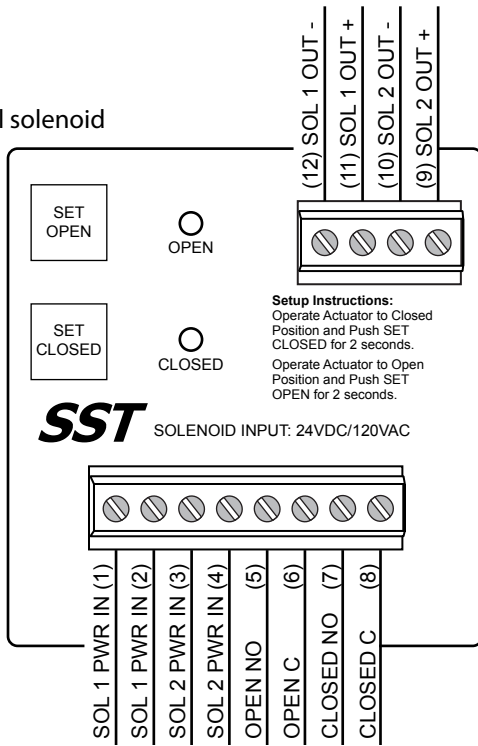

Common receptacle options pin-out

6-PIN MICRO CONNECTOR (M12)

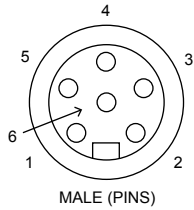

| Pin | Signal |
|-----|--------------------|
| 1 | OPEN/CLOSED C |
| 2 | CLOSED NO |
| 3 | OPEN NO |
| 4 | SOL1 & SOL2 PWR IN |
| 5 | SOL1 PWR IN |
| 6 | SOL2 PWR IN |

6-PIN MINI CONNECTOR

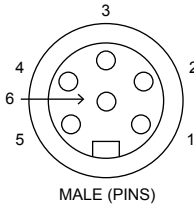

4.1 Sensor/switching modules

4.1.2 SST N.O. sensor; 240 VAC (35)

| Specifications | |
|----------------------------|---|
| Configuration | (2) NO 2-wire solid state sensors |
| Voltage range | 20 - 250 VAC, 8 - 250 VDC |
| Minimum on current | 2.0 mA |
| Maximum continuous current | 0.1 amps |
| Maximum leakage current | 0.5 mA |
| Maximum voltage drop | 6.5 volts @ 10 mA 7.5 volts @ 100 mA |
| Circuit protection | Protected against direct application of voltage up to 20 VDC/125 VAC. No protection at 240 VAC |

WARNING

Do not apply external power to the SOL OUT terminals. This will cause permanent damage to the unit.

Bench test procedure and sensor setting instructions

Power must be applied to both sensors to ensure proper circuit operation. Use a 24 VDC power supply with series load resistor, (2K - 6K Ω), connected to the 24 VDC+.

1. Connect 24 VDC+ to the CLOSED C (common) and OPEN C (common) terminals. Connect 24 VDC- to the CLOSED NO and OPEN NO terminals.
 2. Operate actuator to the closed position.
 3. Press and hold SET CLOSED button until CLOSED LED is lit (2 seconds). Release button.
 4. Operate actuator to the open position.
 5. Press and hold SET OPEN button until OPEN LED is lit (2 seconds). Release button.
 6. Setpoints are retained even after power is removed.
- To electrically test solenoid, apply power to the SOL PWR IN terminals only.

Note

If using only one of the sensors for valve position feedback, the open sensor (green) must be used.

Caution: A series load resistor must be used when bench testing in order to ensure proper module operation.

Wiring diagrams

Single coil solenoid

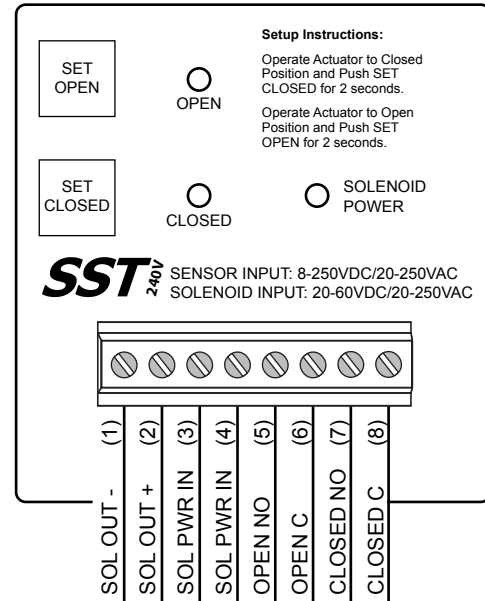

Common receptacle options pin-out

5-PIN MICRO CONNECTOR (M12)

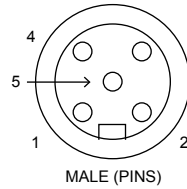

5-PIN MINI CONNECTOR

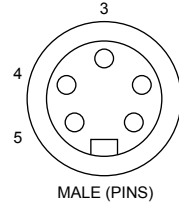

| Pin | Signal |
|-----|---------------|
| 1 | OPEN/CLOSED C |
| 2 | CLOSED NO |
| 3 | OPEN NO |
| 4 | SOL PWR IN + |
| 5 | SOL PWR IN - |

4.1.2 SST N.O. sensor; 240 VAC (35) continued

Wiring diagrams

Dual coil solenoid

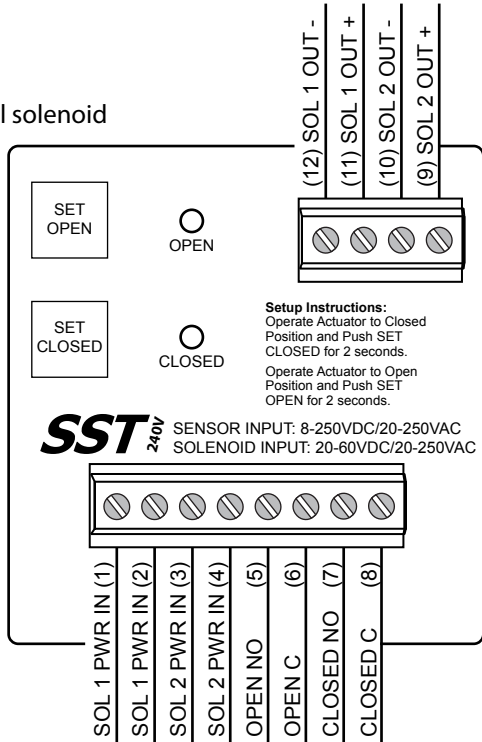

Common receptacle options pin-out

6-PIN MICRO CONNECTOR (M12)

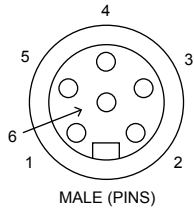

| Pin | Signal |
|-----|--------------------|
| 1 | OPEN/CLOSED C |
| 2 | CLOSED NO |
| 3 | OPEN NO |
| 4 | SOL1 & SOL2 PWR IN |
| 5 | SOL1 PWR IN |
| 6 | SOL2 PWR IN |

6-PIN MINI CONNECTOR

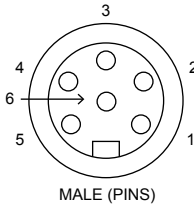

4.1 Sensor/switching modules

4.1.3 NAMUR sensor (44)

| Specifications | | |
|--|--|------------------|
| Configuration | (2) NAMUR sensors (EN 60947-5-6; IS) | |
| Voltage range | 7 - 24 VDC | |
| Current ratings | Target present | Current < 1.0 mA |
| | Target absent | Current > 2.1 mA |
| <i>Use with intrinsically safe repeater barrier. NAMUR sensors conform to EN 60947-5-6 standard.</i> | | |
| Intrinsically safe solenoid coil (E) | | |
| Voltage | 24 VDC to input of solenoid barrier* | |
| | 12 VDC from output of solenoid barrier to coil | |
| *Note: Use of an intrinsically safe 24 VDC solenoid barrier with internal impedance, or end-to-end resistance, of 250 to 305 ohms required for proper solenoid coil operation. | | |

WARNING

Do not apply external power to the SOL OUT terminals. This will cause permanent damage to the unit.

Bench test procedure and sensor setting instructions

Power must be applied to both sensors to ensure proper circuit operation. Use a 24 VDC power supply. A series load resistor is not required when bench testing.

1. Connect 24 VDC+ to the CLOSED + and OPEN + terminals. Connect 24 VDC- to the CLOSED - and OPEN - terminals.
2. Operate actuator to the closed position.
3. Press and hold SET CLOSED button until OPEN LED goes out (2 seconds). Release button.
4. Operate actuator to the open position.
5. Press and hold SET OPEN button until CLOSED LED goes out (2 seconds). Release button. Both OPEN and CLOSED LEDs will be lit during mid-travel.
6. Setpoints are retained even after power is removed.

Note

If using only one of the sensors for valve position feedback, the open sensor (green) must be used.



Reference controlled installation drawing #105157 for proper intrinsic safe installation details. Find document in the Appendix on page 40 or at www.StoneL.com/en/products/axiom/installation-manuals

Wiring diagrams

Single coil solenoid

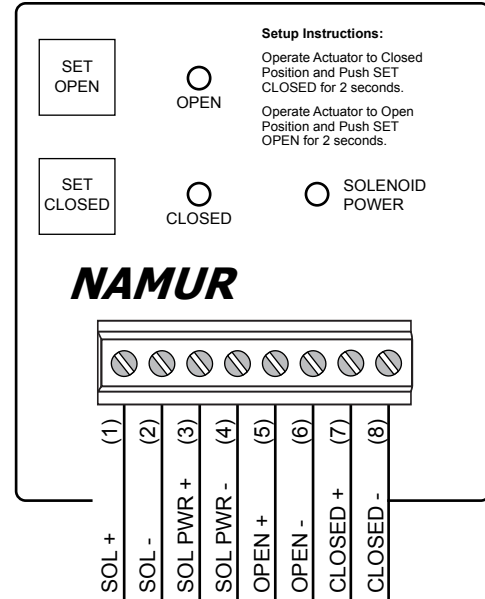

Common receptacle options pin-out

6-PIN MICRO CONNECTOR (M12)

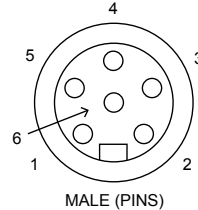

6-PIN MINI CONNECTOR

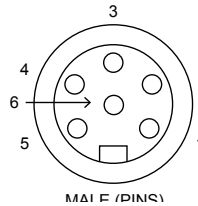

| Pin | Signal |
|-----|-----------|
| 1 | OPEN + |
| 2 | OPEN - |
| 3 | SOL PWR + |
| 4 | CLOSED + |
| 5 | CLOSED - |
| 6 | SOL PWR - |

4.1.3 NAMUR sensor (44) continued

Wiring diagrams

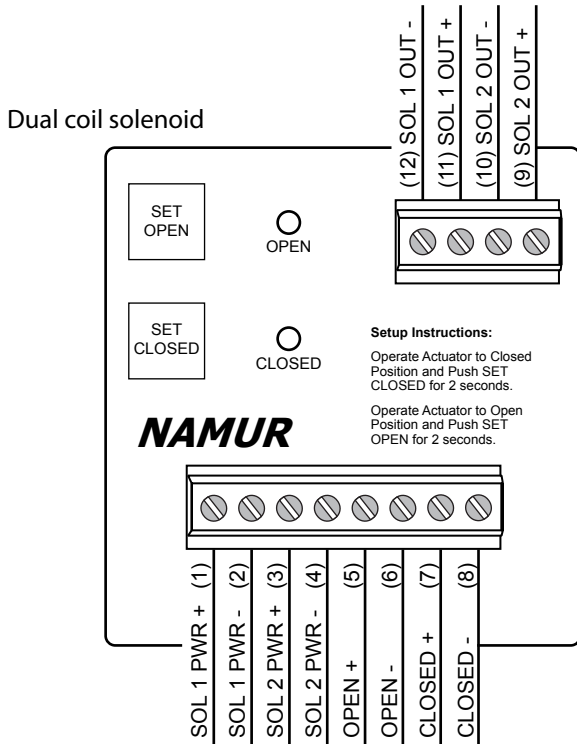

Common receptacle options pin-out

8-PIN MICRO CONNECTOR (M12)

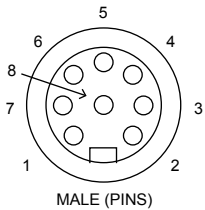

8-PIN MINI CONNECTOR

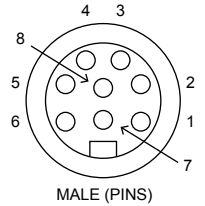

| Pin | Signal |
|-----|---------------|
| 1 | SOL1 PWR IN + |
| 2 | SOL1 PWR IN - |
| 3 | CLOSED + |
| 4 | CLOSED - |
| 5 | SOL2 PWR IN + |
| 6 | SOL2 PWR IN - |
| 7 | OPEN + |
| 8 | OPEN - |

Typical basic intrinsically safe circuits

NAMUR sensor circuit

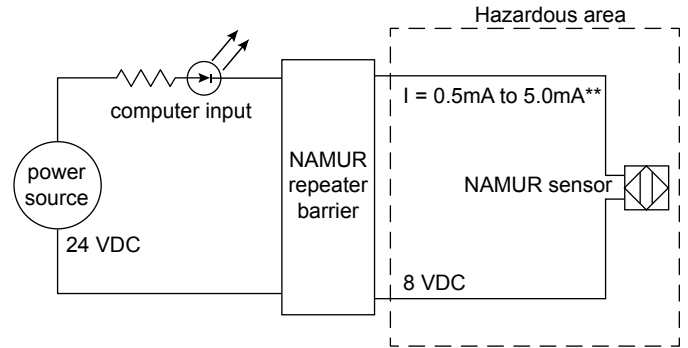

** Barrier off state (target off): current in NAMUR sensor circuit >2.1 mA
Barrier on state (target on): current in NAMUR sensor circuit <1.0 mA

Solenoid circuit

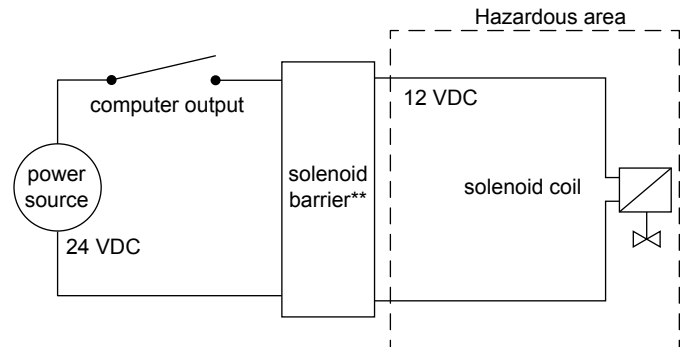

** Use of an intrinsically safe 24 VDC solenoid barrier with internal impedance, or end-to-end resistance, of 250 to 305 ohms required for proper operation of StoneL's intrinsically safe solenoids.

4.1 Sensor/switching modules

4.1.4 Expeditor (80)

| Specifications | |
|------------------------------------|--|
| Position feedback control (AI) | 4-20 mA loop, 9 - 35 VDC |
| Intermediate position control (AO) | 4-20 mA loop, 9 - 35 VDC |
| Position monitoring accuracy | +/- 1° of rotation |
| Intermediate control accuracy | +/- 3° of rotation |
| Solenoid voltage | 24 VDC (conventional models) 12 VDC (intrinsic safety models) |
| Solenoid power | 0.5 watt (20 mA @ 24 VDC) 0.5 watt intrinsically safe (40 mA @ 12 VDC) |
| Cycle life | 500,000 cycles (full cycles with intermediate positioning, cycle life may vary depending on intermediate toggling) |

Wiring diagram

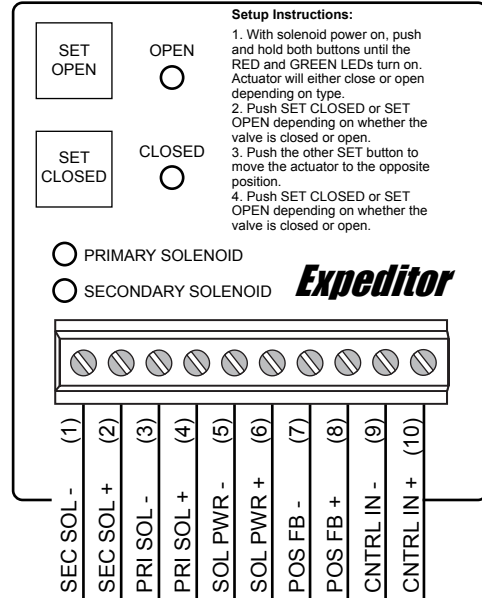

Common receptacle options pin-out

6-PIN MICRO CONNECTOR (M12)

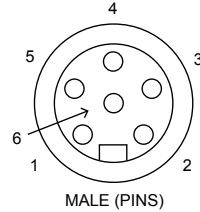

6-PIN MINI CONNECTOR

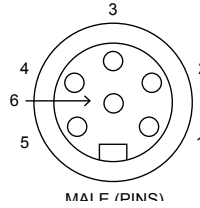

| Pin | Signal |
|-----|------------|
| 1 | CNTRL IN + |
| 2 | CNTRL IN - |
| 3 | POS FB + |
| 4 | POS FB - |
| 5 | SOL PWR + |
| 6 | SOL PWR - |

4.1.4 Expeditor (80) continued

WARNING

Do not apply external power to the primary or secondary solenoid terminals. This will cause permanent damage to the unit.

Description of operation

The Axiom expeditor is a valve monitoring and control package for quarter-turn actuators that require the valve to stop in an intermediate position. Position feedback and intermediate position control are accomplished by two separate 4-20 mA loops.

The Axiom expeditor C-module is powered by a 4-20 mA loop through the position feedback terminals. Therefore, this input is required to be connected to an analog input for calibration and basic operation of the expeditor. The position feedback provides a 4 mA signal for valve closed position, a 20 mA signal for valve open position, and a 4-20 mA feedback signal for any intermediate position. Intermediate positioning control requires a 4-20 mA signal from an analog output to the control input terminals of the C-module. The Axiom expeditor controls the valve/actuator position by the use of an integral dual coil pneumatic solenoid valve. Solenoid power is required from a single discrete output. This single channel provides power to both the primary and secondary pilot valve coils and must be either 24 VDC for nonincendive equipment applications or 12 VDC for intrinsic safety applications (model/application dependent).

Basic operation

Voltage is applied to the solenoid power terminals. This will cause the actuator to fully stroke. Simply remove the solenoid power voltage to fully stroke the valve/actuator to the fail position. The position feedback will provide valve position indication, (4 mA for the closed position or 20 mA for the open position).

Intermediate position control operation

In this mode the expeditor will operate as in basic mode until a 4-20 mA signal from an analog output is applied to the control input terminals. If solenoid power is applied, the valve/actuator will drive to the intermediate control position dictated by the analog output. For example, if the analog output is providing a 12 mA signal, the valve/actuator will drive to the 50% position. The position feedback signal will provide an accurate 4-20 mA signal of valve position that can be monitored by an analog position feedback device.

Note

Solenoid power must be continuously applied for intermediate position control operations. Should the solenoid power be removed at any time, the valve/actuator will drive to the failed position.

Basic installation example

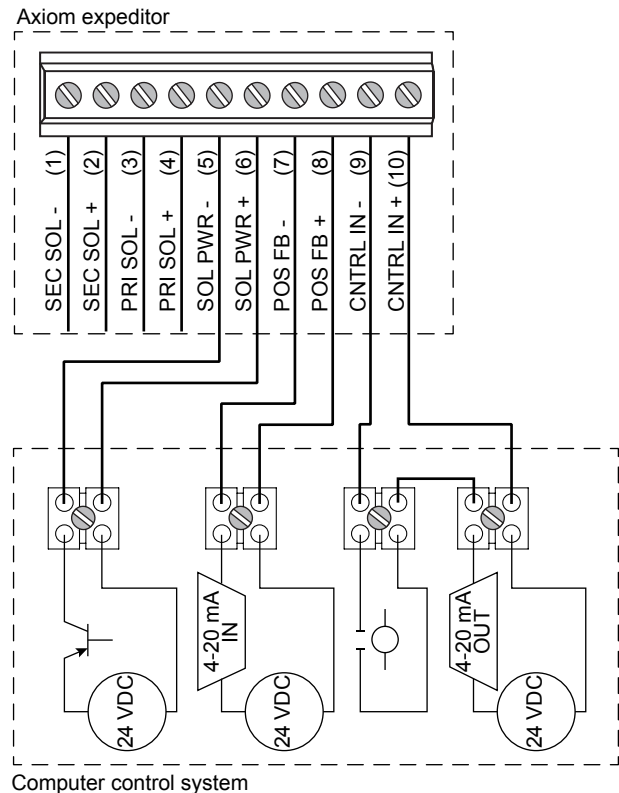

4.1.4 Expeditor (80) continued



Caution: Read all instructions prior to performing this procedure.

Calibration and operating procedures

The Position Feedback terminals (POS FB+ and POS FB-) must be connected to a 4-20 mA Analog Input (or 24 VDC power source when bench testing) and the Solenoid Power terminals (SOL PWR+ and SOL PWR-) must be connected to a Discrete Output (or 24 VDC power source when bench testing) and energized to perform this procedure.

Note

POS FB+ and POS FB- will output 12 mA until both open and closed positions are set.

1. With the Axiom Expeditor connected to the control system (or 24 VDC power sources when bench testing) as instructed above, press and hold both the SET OPEN and SET CLOSED push buttons until both the green OPEN and red CLOSED LEDs light, then release. Both OPEN and CLOSED LEDs will be flashing. The actuator will either open or close, depending on whether it is configured as failed open or failed closed.
2. If the valve/actuator is in the open position from step 1, momentarily press the SET OPEN push button and release. The green OPEN LED will be lit and the open position setpoint programmed.

Or

- If the valve/actuator is in the closed position from step 1, momentarily press the SET CLOSED push button and release. The red CLOSED LED will be lit and the closed position setpoint will be programmed.
3. Based upon the results of step 2, if the green LED is lit, press and release the SET CLOSED push button, or if the red LED is lit, press and release the SET OPEN push button. This will cause the valve/actuator to stroke to that position.
4. After the valve/actuator has fully opened or closed, press and release the corresponding SET OPEN or SET CLOSED push button. This will program that position setpoint and cause the valve/actuator to complete full open/closed cycle.
5. Upon completion of the open/closed cycle, if the valve/actuator is in the open position and only the green OPEN LED is lit or if the valve/actuator is in the closed position and only the red CLOSED LED is lit, unit is ready for normal operation.

Note

If upon completion of the open/closed cycle and both the green OPEN LED and red CLOSED LED are alternately flashing, this indicates the actuator open/close time is too fast and the Stonel supplied adjustable air flow restrictors need to be installed between the Expeditor unit and the actuator. Once the air flow restrictors are installed, the calibration procedure will need to be performed again.

6. Intermediate position control can be verified by applying a 4-20 mA signal to the CNTRL+ and CNTRL- terminals while the solenoid is energized. Verify valve/actuator drove to desired intermediate position. Unit is now ready for normal operation.



Caution: Valve/actuator will automatically stroke while performing this procedure.

Pneumatic valve schematics

Fig. 4 Expeditor pneumatic valve on spring return actuator

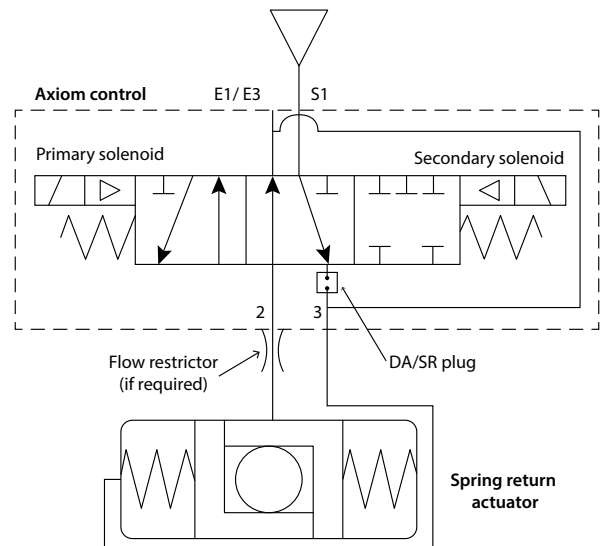
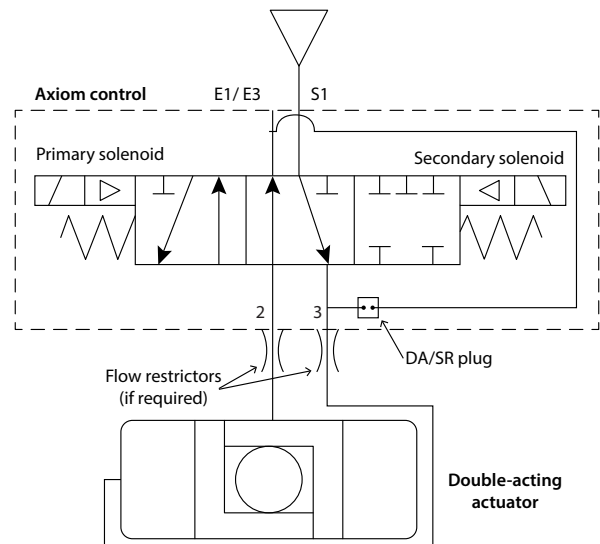

Fig. 5 Expeditor pneumatic valve on double-acting actuator



4.2 Valve communication terminals (VCT)

4.2.1 VCT with HART diagnostics (71D)

| Specifications | | |
|---|-----------------------------|---|
| Communication protocol | HART version 7.0 | |
| Position feedback | Current output | 4-20 mA |
| | Voltage | 14-35 VDC (24 VDC nominal) |
| | Loop resistance | 250 ohms (min) to 400 ohms (max) at 24VDC |
| Pressure accuracy | + 1% of full scale | |
| Solenoid power | Conventional models (D) | 0.5 watt (0.02 amps @ 24VDC) |
| | Intrinsic safety models (E) | 0.5 watt (0.04 amps @ 12VDC) |
| Inputs and outputs | | |
| The Axiom HART C-module comes with an 8-pole terminal block. The terminal block numbering is as indicated | (1) | SOL - (factory wired to solenoid coil) |
| | (2) | SOL+ (factory wired to solenoid coil) |
| | (3) | SOL PWR - (power for solenoid coil) |
| | (4) | SOL PWR+ (power for solenoid coil) |
| | (5) | GND (connected to unit internal ground screw) |
| | (6) | GND (internally connected to terminal #5) |
| | (7) | HART - (HART return) |
| | (8) | HART+ (HART input) |

WARNING

Do not apply external power to the output terminals. This will cause permanent damage to the unit.

Bench test procedure

To test sensors, use a 24 VDC power supply. No series load resistor is required.

1. Apply power across the HART+ and HART- terminal points.
2. Operate actuator to the closed position
3. Press and hold SET CLOSED button until CLOSED LED is lit (2 seconds). Release button.
4. Operate actuator to the open position.
5. Press and hold SET OPEN button until OPEN LED is lit (2 seconds). Release button.
6. Setpoints are retained even after power is removed.

Note

A functioning HART network is required to do basic setup and all other functionalities provided by the HART Sensing and Communications Module.

Calibration instructions

1. With the sensor and communication module (CCM) wired to the control system, power applied to the HART+/- terminals, and solenoid power turned off, press and hold both SET OPEN and SET CLOSED buttons until both the red and green LEDs turn on. Release buttons.
2. If the valve/actuator is in the closed position, push SET CLOSED button and release. If the valve/actuator is in the open position, push SET OPEN button and release.
3. Energize the solenoid.
4. If the valve/actuator goes to the closed position, push SET CLOSED button and release. If the valve/actuator goes to the open position, push SET OPEN button and release.
5. Setpoints are retained even after power is removed.

Wiring diagram

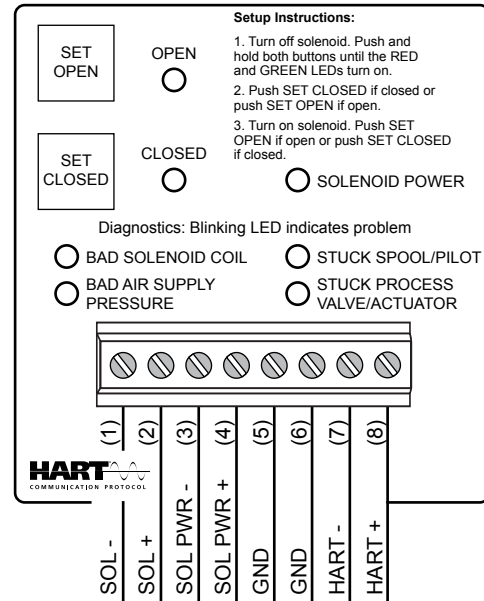

Common receptacle options pin-out

5-PIN MICRO CONNECTOR (M12)

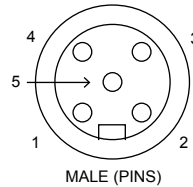

5-PIN MINI CONNECTOR

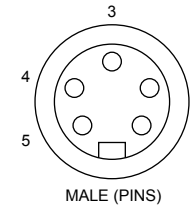

| Pin | Signal |
|-----|-----------|
| 1 | HART - |
| 2 | HART + |
| 3 | SOL PWR - |
| 4 | Ground |
| 5 | SOL PWR + |

4.2.1 VCT with HART diagnostics (71) continued

Description of operation

The Axiom HART is a valve-monitoring package for ¼ turn actuators. It has the added capability of providing diagnostic information on the pilot solenoid, spool valve, and actuator. The device will also store historical data on each cycle.

The Axiom HART (Highway Addressable Remote Transducer) takes advantage of the HART protocol's ability to provide position feedback as well as device variables over 2 wires. HART communication is master/slave over a 4-20 mA current loop. Communication is superimposed on the current loop.

The HART C-module is powered by 24 VDC (14 VDC min). A HART modem and master are required to communicate with the C-module. The C-module will feedback 4 mA for closed or 20 mA for open. It will also provide feedback for any intermediate position.

Solenoid power (24 VDC) is required by the C-module to power the pilot solenoid. For IS applications a special 12 VDC IS coil will be provided.

Connecting the device

The HART C-module requires a power source of 24 VDC. A 250-400 ohm resistor is required between the power source and the HART C-module. A HART modem may be attached across the resistor (or HART unit) to enable communication with the host. See basic installation example below.

Basic operation

To move the actuator/valve, simply apply 24 VDC to the solenoid power input and the actuator will move from closed (4 mA) to open (20 mA). A yellow LED will light on the C-module to indicate power was applied to the solenoid.

LED indications

OPEN (green) and CLOSED (red) LEDs

Will light when the valve position gets within four degrees of either the open or closed setpoint. The valve needs to rotate six degrees away from either the open or closed setpoint in order for that respective LED to turn off.

SOLENOID POWER (yellow)

Lights whenever solenoid power is applied.

BAD SOLENOID COIL (red)

Flashes at 2 Hz whenever there is an open or a short on the pilot coil.

BAD AIR SUPPLY PRESSURE (red)

If the input supply air pressure is below 40 psi or above 110 psi for 3 seconds, the LED will flash at 2 Hz rate. The 40 psi/110 psi pressure levels are factory defaults and may be changed through a HART command.

STUCK SPOOL/PILOT (red)

If pressure to move the actuator is not present within 5 seconds after applying or removing power to the solenoid, and if there is not a bad solenoid or a bad air supply pressure fault, then the LED will flash at 2 Hz rate. The time out is ¼ of the stroke time (5 second with a 20 second stroke time default).

STUCK PROCESS VALVE/ACTUATOR (red)

If, after 20 seconds (factory default), the position sensor doesn't reach its end of travel after the power to the coil has been applied or removed and if there are no other alerts, then the LED will flash at 2 Hz rate. The 20 second stroke time is a factory default and may be changed through a HART command.

Basic installation example

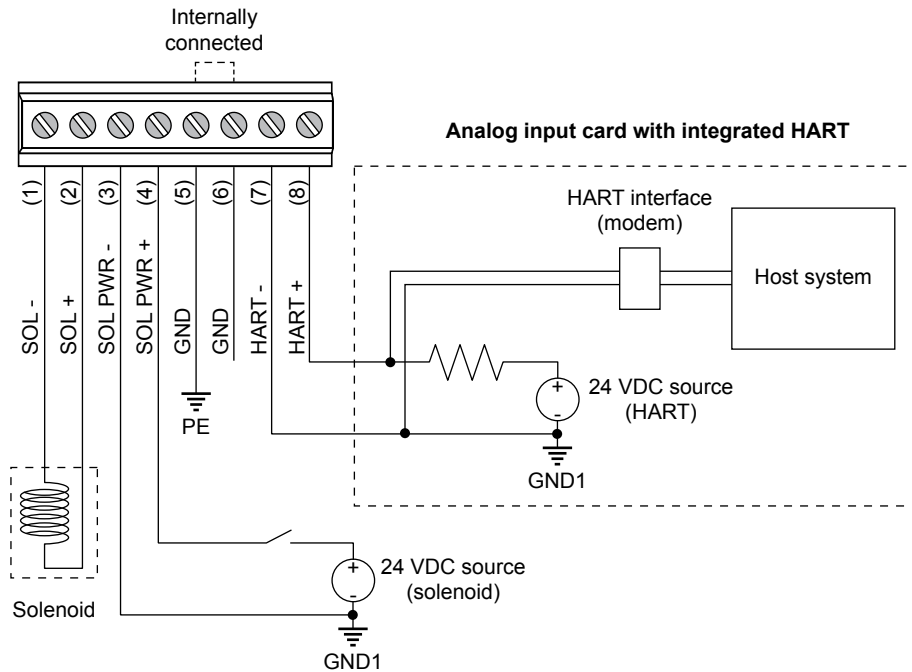

4.2.1 VCT with HART diagnostics (71) continued

Operation overview

The Axiom HART C-module will measure various parameters, store current status, store current and historical data, provide local display indications, and make diagnostic decisions based on the inputs from the sensors. This data will be transmitted, when requested, to the host for display with the use of the StoneL HART EDD files.

Measured parameters

The following is a list of parameters measured by the Axiom HART C-module:

- Position
- Total stroke time (both opening and closing)
- Dead time (time between energizing or de-energizing the solenoid and the actuator moving > 6°) for both opening and closing
- Coil status (good or bad)
- Temperature (internal electronics temperature)
- Cycle count
- Inlet supply air pressure
- Air pressure at A
- Air pressure at B

Status indicators transmitted over HART

The following is a list of status indicators that are displayed locally and transmitted to the host for display:

- Valve open
- Valve closed
- Solenoid energized
- Bad solenoid coil
- Bad supply pressure
- Stuck spool/pilot
- Stuck valve/actuator

List of parameters transmitted over HART

This is a list of parameters the C-module measures and records. They are transmitted through HART when requested by the host:

- Breakaway pressure (derived from the differential pressure A-B) both at opening and closing
- Total time to open – the time from when the coil is energized to when the open sensor is energized
- Total time to close – the time from when the coil is de-energized to when the closed sensor is energized
- Dead time to open – the time it takes to breakaway from the seat when the valve is closed and is directed to open
- Dead time to close – time it takes to breakaway from the seat when the valve is open and directed to close
- Electronics temperature – both opening and closing
- Cycle count
- Inlet air pressure
- Change in closed position from setpoint

Baseline set up

The baseline cycle will be stored so that the user can compare all measured variables with the baseline value. This way, they will be able to determine if the valve is working properly or not or if the valve is possibly about to fail. This will be done in one of two ways. The first will be a command sent via the protocol to set the last stroke as the baseline. The second way is that the baseline will be automatically set as the 50th stroke. This will be transparent to the end user so if he forgets to set the baseline (or doesn't know to do it), it will still get set.

The baseline stroke will store the following parameters:

- Open dead time
- Breakaway pressure to open
- Open time
- Temperature when opening
- Close dead time
- Breakaway pressure to close
- Close time
- Temperature when closing

C-module commands

The following is a list of commands that can be sent over HART to change or manipulate parameter set points or other features:

1. **Wink feature:** When a Wink command is received from the protocol, both the OPEN and CLOSED LEDs will flash at a rate of 2 Hz. This will continue until another Wink command is received.
2. **Remote set open/close:** Open/close positions can be remotely set via the protocol. Determination of fail open, fail close, clockwise or counterclockwise operation is made automatically during set up.
3. **Set baseline:** Used to set the last cycle as the baseline.
4. **Clear cycle count:** Clears cycle count to zero. Also erases all history and baseline data.
5. **Change pressure alarms:** Change the low pressure alarm from 40 PSI to a range of 40 to 95 PSI. Change high pressure alarm from 110 PSI to range of 100 to 120 PSI.
6. **Change pressure units:** Set pressure units to either PSI or BAR. Doing this will also cause a clear cycle count.
7. **Set to defaults:** Set unit back to factory defaults:
 - Pressure units = PSI
 - Low pressure alarm = 40 PSI
 - High pressure alarm = 110 PSI
 - Stroke time = 20 seconds
 - Stuck pilot = 5 seconds

4.2.1 VCT with HART diagnostics (71) continued

Operation overview

There are 4 main screens to view the HART device status: Device Variables screen, Device Diagnostics screen, Historical Data, and Online screen.

Device Variables screen

This screen, shown below, will graphically and numerically display the process variables of the device. Position is displayed in 1/2 degree increments and in current (4-20 mA). It will display pressure in psi or bar. The temperature will be displayed in degrees C. Also shown are position status either OPEN or CLOSED, solenoid power, cycle count, as well as a see device diagnostic indication. If the see device diagnostic light is on there is some issue with the device that needs attention. To view the issue, go to the view menu and select the device diagnostics page.

Observe / Device Variables

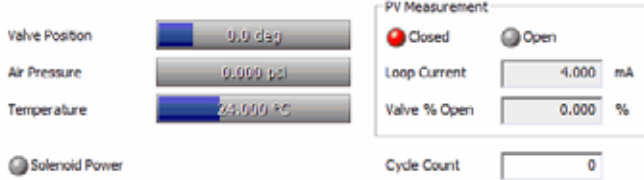

Device Diagnostics screen

To view diagnostic information and historical data on the device select the Device Diagnostic screen. The identity box relates to HART related info on the device. The Device Status box has status/warning flags for HART related communications. The Operation Warning box will give warning indications about the function of the device. A green indication is a good condition while a red indicates a problem or in the case of baseline not set the baseline has not been set.

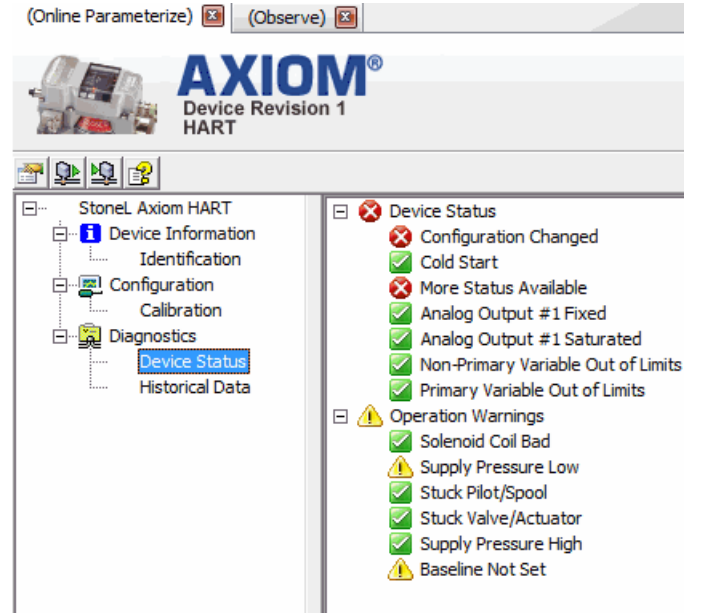

Operation overview continued

Historical Data screen

On the Device Diagnostic screen there is a button labeled Historical Data. Click on the button to access the historical cycle data taken by the device. The Historical Data screen below shows the open dead time of a unit with 11 cycles on it as well as the base line data on the far right colored in blue. There are 9 parameters saved for each cycle. Just click on the tab of interest to view the history of that parameter. The last 16 cycles are displayed on the first row of bar graphs. The bar graphs in the second row are averaged sets of 16 cycles each. The third row is averaged sets of 256 cycles each, the fourth row 4096 averaged cycles each, the fifth row 65536 averaged cycles each. Data is compressed or averaged for 1 million cycles.



4.2.1 VCT with HART diagnostics (71) continued

Online screen

The Online screen is where functional changes to the device are made. Below is a list of those changes:

1. Pressure units button: click button to change from PSI to BAR
2. Low alarm pressure: type in a new value of 40 to 95 psi
3. High alarm pressure: type in a new value of 100 to 120 psi
4. Stroke time: type in a value from 2 to 650 seconds
5. Set open switch: while in the open position push this button to set to 20 mA
6. Set closed switch: while in the closed position push this button to set to 4 mA
7. Clear cycle count: click button to clear the cycle count and history
8. Set baseline: click button to set the last cycle as baseline. Otherwise the fiftieth cycle will be chosen
9. Set to defaults: click this button to return pressure alarms, pressure unit and stroke time to factory defaults:
 - Pressure units = psi
 - Low pressure alarm = 40 psi
 - High pressure alarm = 110 psi
 - Stroke time = 20 seconds
 - Stuck pilot = 5 seconds
10. Wink: click button to enable/disable the Wink feature

The Online screen also has tabs to perform loop current calibration and loop tests:

Loop test

This method allows the user to set the loop current to a fixed value. This is often also used when setting up or maintaining a loop to verify that the loop is active or trace the loop from the transmitter to the control room. The loop test also allows the user to check out other devices in series with the loop such as current monitors, etc. The method provides fixed choices of 4, 12 and 20 mA, as well as allowing the user to input a value between 4 and 20 mA of his choosing.

D/A Trim

This method allows the user to trim the loop current to match his plant meters. The procedure first trims the 4 mA output to match his local meter and then the 20 mA output again to match his local meter.

The screenshot displays the 'Calibration' screen for the 'StoneL Axiom HART' device. The interface includes a top navigation bar with '(Online Parameterize)' and '(Observe)' buttons. Below the navigation bar is the 'AXIOM Device Revision 1 HART' logo and a set of icons. A left-hand tree view shows the following menu items: StoneL Axiom HART, Device Information, Identification, Configuration, Calibration (highlighted), Diagnostics, Device Status, and Historical Data. The main content area is titled 'Calibration' and is divided into three sections:

- Calibrate Valve:** Contains input fields for 'Pressure Unit' (set to 'psi'), 'Low Alarm Pressure' (40 psi), 'High Alarm Pressure' (110 psi), 'Stroke Time' (20 s), and 'Cycle Count' (0). Below these fields are two buttons: 'Set Open Switch' and 'Set Close Switch'.
- Configure Diagnostics:** Contains four buttons: 'Clear Cycle Count', 'Set Baseline', 'Set to Defaults', and 'Wink'.
- Loop Current Cal:** Contains two buttons: 'DA Trim' and 'Loop test'.

4.2 Valve communication terminals (VCT)

4.2.2 VCT with DeviceNet™ communication (92S)

| Specifications | |
|--------------------------------------|--|
| Communication protocol | DeviceNet™ |
| Configuration | (2) Discrete Inputs (sensors) (1) Auxiliary analog input (4-20 mA) (2) Discrete Outputs (solenoids) |
| Input voltage | 11 - 24 VDC via DeviceNet™ network |
| Output voltage | 24 VDC |
| Analog input impedance | 254 ohms |
| Quiescent current | No analog input, no outputs energized: 45 mA @ 24 VDC; 69 mA @ 11 VDC |
| Current consumption (coil energized) | 66 mA @ 24 VDC - 0.5 w coil (D) 120 mA @ 24 VDC - 1.8 w coil (B) |
| Maximum output current | 160 mA (4 watts; both outputs combined) |
| Default address | 63 (software assigned) |
| Default baud rate | 125K (software selectable 125K, 250K or 500K baud) |
| Messaging | Polling, cyclic and change of state |
| DeviceNet™ type | 100 |
| Bit mapping | Inputs (3 bytes) Byte 0, bit 0 = red LED / valve closed Byte 0, bit 1 = green LED / valve open Byte 0, bit 7 = fault bit Byte 1, bits 8-15 = analog input Byte 2, bits 16-23 = analog input (4-20 mA analog input 0-10,000 scaling) Outputs (1 byte) Byte 0, bit 0 = solenoid 1 Byte 0, bit 1 = solenoid 2 Byte 0, bit 2 = wink Byte 0, bit 3 = remote set closed Byte 0, bit 4 = remote set open |

WARNING

Do not apply external power to the output terminals. This will cause permanent damage to the unit.

Bench test procedure and sensor setting instructions

To test sensors, use a 24 VDC power supply. No series load resistor is required.

1. Apply power across the V+ and V- terminal points.
 2. Operate actuator to the closed position.
 3. Press and hold SET CLOSED button until CLOSED LED is lit (2 seconds). Release button.
 4. Operate actuator to the open position.
 5. Press and hold SET OPEN button until OPEN LED is lit (2 seconds). Release button.
 6. Setpoints are retained even after power is removed.
- A functioning DeviceNet™ network is required to test communications and solenoids.

Caution: Power cycling unit with byte 0, bit 3 or bit 4 set will cause the sensor(s) to set at that valve position. Ensure byte 0, bit 3 and bit 4 are reset to 0 after performing a remote sensor setting.

Wiring diagrams

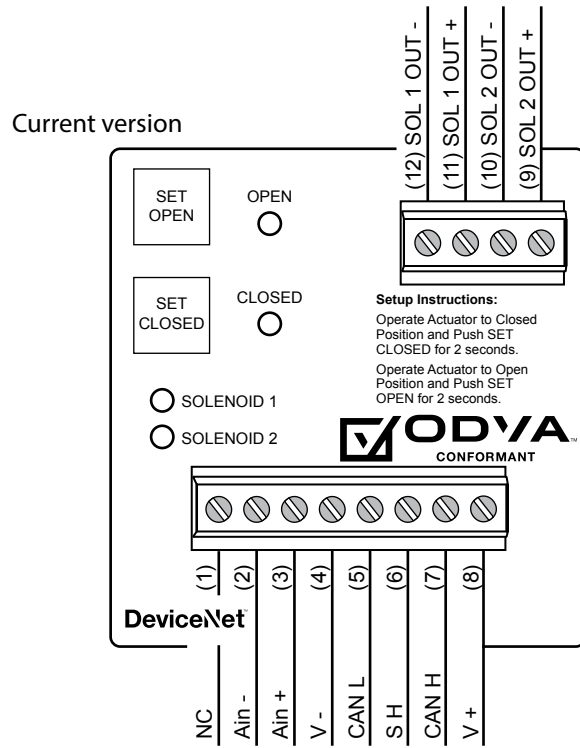

Common receptacle options pin-out

5-PIN MICRO CONNECTOR (M12)

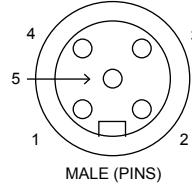

5-PIN MINI CONNECTOR

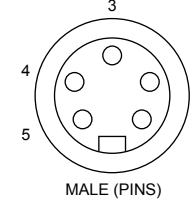

| Pin | Signal |
|-----|--------|
| 1 | Shield |
| 2 | V + |
| 3 | V - |
| 4 | CAN H |
| 5 | CAN L |

4.2.2 VCT with DeviceNet™ communication (92S) continued

Wiring diagrams

Previous version

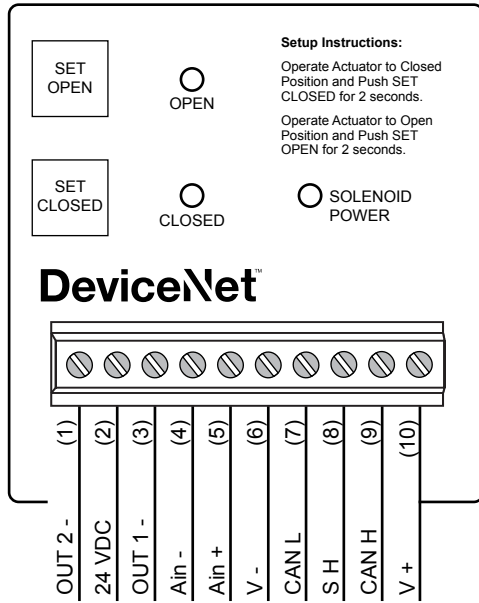

Remote sensor setting feature

The remote sensor setting feature provides the capability of setting the closed and open sensors remotely from the control system.

1. DeviceNet™ communications are required in order to remotely set the sensors. The unit must be addressed and correctly configured to be recognized by the control system.
2. With the valve/actuator in the closed position, set byte 0, bit 3 to 1 for at least two seconds. This will set the closed sensor to that valve/actuator position. Set byte 0, bit 3 back to 0.
3. With the valve/actuator in the open position, set byte 0, bit 4 to 1 for at least two seconds. This will set the open sensor to that valve/actuator position. Set byte 0, bit 4 back to 0.

DeviceNet™ Wink feature

The Wink feature provides the capability of setting the CLOSED and OPEN LEDs to simultaneously flash or wink at a 2 Hz rate. This feature aids in physically locating the unit on the network.

1. DeviceNet™ communications are required in order to set the Wink feature. The unit must be addressed and correctly configured to be recognized by the control system.
2. Set byte 0, bit 2 to 1 in the desired unit. Once the correct unit has been physically located on the network, indicated by the winking of the CLOSED and OPEN LEDs, set byte 0 bit 2 back to 0. Performing this function will not change the closed and open sensor setpoints.

Common receptacle options pin-out

5-PIN MICRO CONNECTOR (M12)

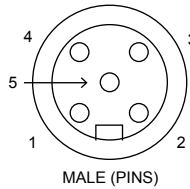

5-PIN MINI CONNECTOR

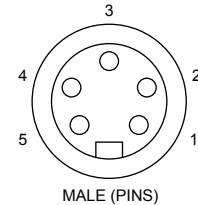

| Pin | Signal |
|-----|--------|
| 1 | Shield |
| 2 | V + |
| 3 | V - |
| 4 | CAN H |
| 5 | CAN L |

DeviceNet™ Fault indication (input byte 0, bit 7)

1. The Fault indication will set to a 1 when input byte 0, bits 0 and 1 are set to 1 at the same time.
2. When input byte 0, bits 0 and 1 are both set to 1, this would indicate that the valve is both open and closed at the same time. This would be an abnormal or Fault condition.

4.2 Valve communication terminals (VCT)

4.2.3 VCT with Foundation Fieldbus communication (93S)

| Specifications | | |
|---------------------------------|---|---------------------|
| Communication protocol | Foundation Fieldbus (H1) | |
| Configuration | (2) Discrete Inputs (sensors) (2) Discrete Outputs (piezo valves) | |
| Function blocks | 2 DI; 2 DO | |
| Execution time | Maximum 30 ms per DI and DO | |
| Voltage | 9 - 32 VDC (bus voltage) | |
| Output voltage | 6.5 VDC | |
| Quiescent current | 16 mA | |
| Maximum output current | 2.0 mA @ 6.5 VDC | |
| Devices per network | Maximum of 16 devices recommended | |
| Standard channel assignments | | |
| Channel 1 (DI1) | Discrete Input 1 (red LED) | 1 = true; 0 = false |
| Channel 2 (DI2) | Discrete Input 1 (green LED) | 1 = true; 0 = false |
| Channel 3 (DO1) | Discrete Output 1 (OUT 1) | 1 = true; 0 = false |
| Channel 4 (DO2) | Discrete Output 1 (OUT 2) | 1 = true; 0 = false |
| Special channel assignments | | |
| Channel 8 (DO1) | Discrete Output 1 (OUT 1) with state report from Discrete Input 1 (READBACK_D) | |
| Channel 9 (DO2) | Discrete Output 2 (OUT 2) with state report from Discrete Input 2 (READBACK_D) | |
| Valve control single block mode | | |
| Channel 10 (DO1) | Discrete Output 1 (OUT 1) will state report Discrete Inputs 1&2 (READBACK_D) | |
| READBACK_D values | 0 = none 1 = Discrete Input 1 is true 2 = Discrete Input 2 is true 3 = both discrete inputs 1&2 are true | |



Reference controlled installation drawing #105157 for proper intrinsic safe installation details. Find document in the Appendix or at www.StoneL.com/en/products/axiom/installation-manuals

Wiring diagram

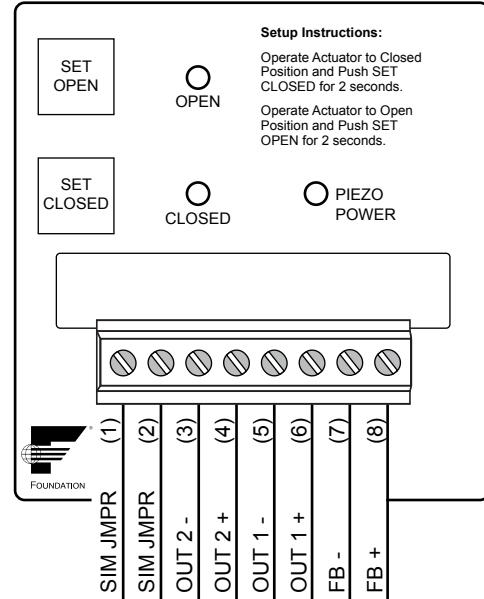

WARNING
Do not apply external power to the output terminals. This will cause permanent damage to the unit.

Bench test procedure and sensor setting instructions

To test sensors, use a 9-32 VDC power supply. No series load resistor is required.

1. Apply power across the FB+ and FB- terminal points.
2. Operate actuator to the closed position.
3. Press and hold SET CLOSED button until CLOSED LED is lit (2 seconds). Release button.
4. Operate actuator to the open position.
5. Press and hold SET OPEN button until OPEN LED is lit (2 seconds). Release button.
6. Setpoints are retained even after power is removed.

A functioning Foundation Fieldbus network is required to test communications.

Common receptacle options pin-out

4-PIN MICRO CONNECTOR (M12)

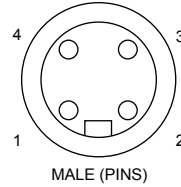

4-PIN MINI CONNECTOR

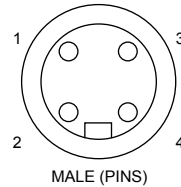

| Pin | Signal |
|-----|----------|
| 1 | FB - |
| 2 | FB + |
| 3 | not used |
| 4 | not used |

4.2 Valve communication terminals (VCT)

4.2.4 VCT with Foundation Fieldbus communication with externally powered outputs (94S)

| Specifications | |
|---|--|
| Communication protocol | Foundation Fieldbus (H1) |
| Configuration | (2) Discrete Inputs (sensors) (2) Externally powered Discrete Outputs |
| Function blocks | 2 DI; 2 DO |
| Execution time | Maximum 30 ms per DI and DO |
| Bus voltage | 9 - 32 VDC via Foundation Fieldbus network |
| Quiescent current | 16 mA |
| External power current consumption (coil energized) | Discrete Outputs - total 160 mA available (4 watts; both outputs combined) 21 mA - 0.5 w coil 75 mA - 1.8 w coil |
| External voltage | 24 VDC (Discrete Outputs) |
| Indication | Input 1 = red LED Input 2 = green LED |
| Devices per network | Maximum of 16 devices recommended |
| Standard channel assignments | |
| Channel 1 (DI1) | Discrete Input 1 (red LED) 1 = true; 0 = false |
| Channel 2 (DI2) | Discrete Input 1 (green LED) 1 = true; 0 = false |
| Channel 3 (DO1) | Discrete Output 1 (OUT 1) 1 = true; 0 = false |
| Channel 4 (DO2) | Discrete Output 1 (OUT 2) 1 = true; 0 = false |
| Special channel assignments | |
| Channel 8 (DO1) | Discrete Output 1 (OUT 1) with state report from Discrete Input 1 (READBACK_D) |
| Channel 9 (DO2) | Discrete Output 2 (OUT 2) with state report from Discrete Input 2 (READBACK_D) |
| Valve control single block mode | |
| Channel 10 (DO1) | Discrete Output 1 (OUT 1) will state report Discrete Inputs 1&2 (READBACK_D) |
| READBACK_D values | 0 = none 1 = Discrete Input 1 is true 2 = Discrete Input 2 is true 3 = both Discrete Inputs 1&2 are true |

WARNING

Do not apply external power to the output terminals. This will cause permanent damage to the unit.

Bench test procedure and sensor setting instructions

To test sensors, use a 9 to 32 VDC power supply. No series load resistor is required.

1. Apply power across the FB+ and FB- terminal points.
2. Operate actuator to the closed position.
3. Press and hold SET CLOSED button until CLOSED LED is lit (2 seconds). Release button.
4. Operate actuator to the open position.
5. Press and hold SET OPEN button until OPEN LED is lit (2 seconds). Release button.
6. Setpoints are retained even after power is removed. A functioning Foundation Fieldbus network is required to test communications and the discrete outputs.

An external 24 VDC to 24 VDC IN+ and 24 VDC IN- is required to energize solenoids connected to the discrete outputs.

Wiring diagram

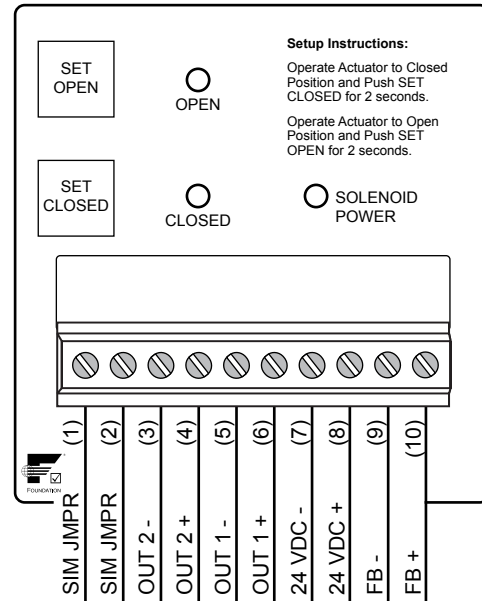

Common receptacle options pin-out

4-PIN MICRO CONNECTOR (M12)

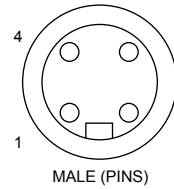

4-PIN MINI CONNECTOR

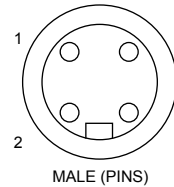

| Pin | Signal |
|-----|----------|
| 1 | FB - |
| 2 | FB + |
| 3 | 24 VDC + |
| 4 | 24 VDC - |

4.2 Valve communication terminals (VCT)

4.2.5 VCT with AS-Interface communication (96S)

| Specifications | | | | | | | | | | | |
|------------------------|---|--------|---------|---------------------|------------------|---------------------|------------------|-------------------|---------------|-----------------|---------------|
| Communication protocol | AS-Interface v3.0 | | | | | | | | | | |
| Configuration | (2) Discrete Inputs (sensors) (2) Auxiliary Discrete Inputs (2) Discrete Outputs (solenoids) | | | | | | | | | | |
| Input voltage | 26.5 - 31.6 VDC (AS-I voltage) | | | | | | | | | | |
| Output voltage | 24 VDC (+/- 10%) | | | | | | | | | | |
| Quiescent current | 21 mA | | | | | | | | | | |
| Current Consumption | 42 mA - 0.5 w coil (D) 96 mA - 1.8 w coil (B) | | | | | | | | | | |
| Maximum output current | 160 mA (4 watts; both outputs combined) | | | | | | | | | | |
| Default address | 00 | | | | | | | | | | |
| ID/IO codes | ID = F; IO = 4; ID1 = F; ID2 = E (S,4.F.E.) | | | | | | | | | | |
| Bit assignment | <table border="0"> <tr> <td>Inputs</td> <td>Outputs</td> </tr> <tr> <td>Bit 0 = aux Input 1</td> <td>Bit 0 = not used</td> </tr> <tr> <td>Bit 1 = aux input 2</td> <td>Bit 1 = not used</td> </tr> <tr> <td>Bit 2 = green LED</td> <td>Bit 2 = OUT 1</td> </tr> <tr> <td>Bit 3 = red LED</td> <td>Bit 3 = OUT 2</td> </tr> </table> | Inputs | Outputs | Bit 0 = aux Input 1 | Bit 0 = not used | Bit 1 = aux input 2 | Bit 1 = not used | Bit 2 = green LED | Bit 2 = OUT 1 | Bit 3 = red LED | Bit 3 = OUT 2 |
| Inputs | Outputs | | | | | | | | | | |
| Bit 0 = aux Input 1 | Bit 0 = not used | | | | | | | | | | |
| Bit 1 = aux input 2 | Bit 1 = not used | | | | | | | | | | |
| Bit 2 = green LED | Bit 2 = OUT 1 | | | | | | | | | | |
| Bit 3 = red LED | Bit 3 = OUT 2 | | | | | | | | | | |

WARNING

Do not apply external power to the output terminals. This will cause permanent damage to the unit.

Bench test procedure and sensor setting instructions

To test sensors, use a 24 VDC power supply. No series load resistor is required.

1. Apply power across the ASi+ and ASi- terminal points.
 2. Operate actuator to the closed position.
 3. Press and hold SET CLOSED button until CLOSED LED is lit (2 seconds). Release button.
 4. Operate actuator to the open position.
 5. Press and hold SET OPEN button until OPEN LED is lit (2 seconds). Release button.
 6. Setpoints are retained even after power is removed.
- A functioning AS-Interface network is required to test communications.

Wiring diagram

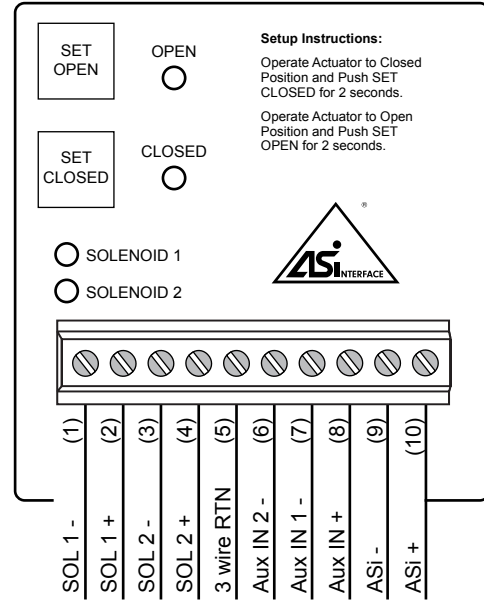

Common receptacle options pin-out

4-PIN MICRO CONNECTOR (M12)

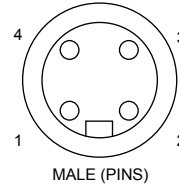

4-PIN MINI CONNECTOR

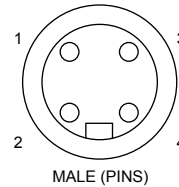

| Pin | Signal |
|-----|----------|
| 1 | ASi + |
| 2 | not used |
| 3 | ASi - |
| 4 | not used |

4.2 Valve communication terminals (VCT)

4.2.6 VCT with AS-Interface communication with diagnostics (96D)

| Specifications | | | | | | | | | | | | | | | | | | | | | |
|---------------------------------|--|--------|---------|-----------------------------|---------------------------------|--------------------------------|--------------------------------|---------------------------------|------------------|---------------------------------|----------------------|-------|-----------------------------|--|------------------------------|-------------------------|----------|---|------------------|---|--|
| Communication protocol | AS-Interface v3.0 | | | | | | | | | | | | | | | | | | | | |
| Configuration | (2) Discrete Inputs (sensors) (1) Discrete Output (solenoid) Onboard diagnostics with LEDs | | | | | | | | | | | | | | | | | | | | |
| Input voltage | 26.5 - 31.6 VDC (AS-I voltage) | | | | | | | | | | | | | | | | | | | | |
| Output voltage | 24 VDC (+/- 10%) | | | | | | | | | | | | | | | | | | | | |
| Quiescent current | 21 mA | | | | | | | | | | | | | | | | | | | | |
| Current Consumption | 42 mA - 0.5 w coil (D) | | | | | | | | | | | | | | | | | | | | |
| Default address | 00 | | | | | | | | | | | | | | | | | | | | |
| ID/IO codes | ID = F; IO = 7 (4DI/4DO) (S.7.FE.) | | | | | | | | | | | | | | | | | | | | |
| Bit assignment | <table border="0"> <tr> <td>Inputs</td> <td>Outputs</td> </tr> <tr> <td>Bit 0 = low supply pressure</td> <td>Bit 0 = remote set close sensor</td> </tr> <tr> <td>Bit 1 = stuck valve / actuator</td> <td>Bit 1 = remote set open sensor</td> </tr> <tr> <td>Bit 2 = open sensor (green LED)</td> <td>Bit 2 = solenoid</td> </tr> <tr> <td>Bit 3 = closed sensor (red LED)</td> <td>Bit 3 = wink feature</td> </tr> </table> <p>Parameters</p> <table border="0"> <tr> <td>Bit 0</td> <td>0 = spring to open actuator</td> </tr> <tr> <td></td> <td>1 = spring to close actuator</td> </tr> <tr> <td>Bit 1, bit 2, and bit 3</td> <td>not used</td> </tr> </table> <p>Peripheral fault bit (pertains v2.1 or higher ASi masters only)</p> <table border="0"> <tr> <td>0</td> <td>= normal status;</td> </tr> <tr> <td>1</td> <td>= bad solenoid coil or stuck spool / pilot valve</td> </tr> </table> | Inputs | Outputs | Bit 0 = low supply pressure | Bit 0 = remote set close sensor | Bit 1 = stuck valve / actuator | Bit 1 = remote set open sensor | Bit 2 = open sensor (green LED) | Bit 2 = solenoid | Bit 3 = closed sensor (red LED) | Bit 3 = wink feature | Bit 0 | 0 = spring to open actuator | | 1 = spring to close actuator | Bit 1, bit 2, and bit 3 | not used | 0 | = normal status; | 1 | = bad solenoid coil or stuck spool / pilot valve |
| Inputs | Outputs | | | | | | | | | | | | | | | | | | | | |
| Bit 0 = low supply pressure | Bit 0 = remote set close sensor | | | | | | | | | | | | | | | | | | | | |
| Bit 1 = stuck valve / actuator | Bit 1 = remote set open sensor | | | | | | | | | | | | | | | | | | | | |
| Bit 2 = open sensor (green LED) | Bit 2 = solenoid | | | | | | | | | | | | | | | | | | | | |
| Bit 3 = closed sensor (red LED) | Bit 3 = wink feature | | | | | | | | | | | | | | | | | | | | |
| Bit 0 | 0 = spring to open actuator | | | | | | | | | | | | | | | | | | | | |
| | 1 = spring to close actuator | | | | | | | | | | | | | | | | | | | | |
| Bit 1, bit 2, and bit 3 | not used | | | | | | | | | | | | | | | | | | | | |
| 0 | = normal status; | | | | | | | | | | | | | | | | | | | | |
| 1 | = bad solenoid coil or stuck spool / pilot valve | | | | | | | | | | | | | | | | | | | | |

Wiring diagram

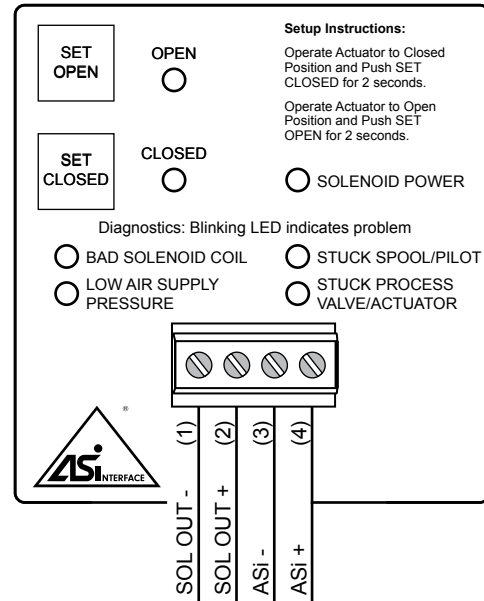

WARNING

Do not apply external power to the output terminals. This will cause permanent damage to the unit.

Bench test procedure and sensor setting instructions

To test sensors, use a 24 VDC power supply. No series load resistor is required.

1. Apply power across the ASi+ and ASi- terminal points.
2. Operate actuator to the closed position.
3. Press and hold SET CLOSED button until CLOSED LED is lit (2 seconds). Release button.
4. Operate actuator to the open position.
5. Press and hold SET OPEN button until OPEN LED is lit (2 seconds). Release button.
6. Setpoints are retained even after power is removed.

A functioning AS-Interface network is required to test communications.

Caution: Valve/actuator will automatically stroke while performing this procedure.

Common receptacle options pin-out

4-PIN MICRO CONNECTOR (M12)

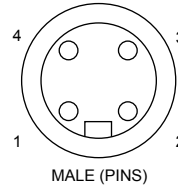

4-PIN MINI CONNECTOR

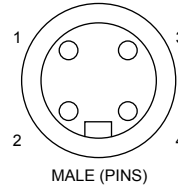

| Pin | Signal |
|-----|----------|
| 1 | ASi + |
| 2 | not used |
| 3 | ASi - |
| 4 | not used |

Stroke time alarm adjustment procedure

1. Read all instructions prior to performing this procedure. Ensure the closed and open sensors have been set prior to performing the stroke time alarm adjustment procedure.
2. The stroke time alarm is adjustable from 1 to 60 seconds. AS-Interface communications is not needed to perform this procedure, however, a 24 VDC power source connected to the ASi+ and ASi- and an air source of a minimum of 40 psi connected to the Axiom supply pressure port (Port 1) will be required.
3. With the valve/actuator in the closed position, verify there are no Fault indications, then press and hold both the SET CLOSED and SET OPEN buttons until both the CLOSED and OPEN LEDs are lit (2 seconds). Release both buttons, the red CLOSED LED should be flashing.
4. Push the SET CLOSED button to start the timer function. The valve/actuator will automatically open and the OPEN LED start to flash.
5. After the valve/actuator has fully opened, wait the desired time the stroke time alarm is to be set to (1 to 60 seconds), then push the SET OPEN button. This will stop the timer function and the valve/actuator will automatically go back to the closed position.
6. The unit is ready to resume normal operation.

4.2.6 VCT with AS-Interface communication with diagnostics (96D) continued

Remote sensor setting procedure

The Axiom with diagnostics provides the capability of setting the closed and open sensors remotely from the control system or from the AS-Interface gateway/master.

1. AS-Interface communications are required in order to remotely set the sensors. The unit must be addressed and correctly configured to be recognized by the control system or the AS-Interface gateway/master.
2. With the valve/actuator in the closed position, set output bit 1 (DO 0) to 1 for at least two seconds. This will set the closed sensor to that valve/actuator position. Set output bit 1 (DO 0) back to 0.
3. With the valve/actuator in the open position, set output bit 2 (DO 1) to 1 for at least two seconds. This will set the open sensor to that valve/actuator position. Set output bit 2 (DO 1) back to 0.

AS-Interface Wink feature

The Axiom with diagnostics provides the capability of setting the CLOSED and OPEN LEDs to simultaneously flash or wink. This feature aids in physically locating the unit on the network.

1. AS-Interface communications are required in order to set the Wink feature. The unit must be addressed and correctly configured to be recognized by the control system or the AS-Interface gateway/master.
2. Set output bit 4 (DO 3) to 1 in the desired unit. Once the correct unit has been physically located on the network, indicated by the winking of the CLOSED and OPEN LEDs, set output bit 4 (DO 3) back to 0. Performing this function will not change the closed and open sensor set points.

| Diagnostic LED indications and interpretation | | | | |
|---|-----------|----------------------------------|-------------------|---|
| LED | LED color | Function description | Operational state | Description |
| OPEN | Green | Process valve is open | Normal operation | LED will be continuously lit when process valve is open |
| CLOSED | Red | Process valve is closed | Normal operation | LED will be continuously lit when process valve is open |
| SOLENOID POWER | Yellow | Solenoid valve is energized | Normal operation | LED will be continuously lit when solenoid is energized |
| BAD SOLENOID COIL | Red | Solenoid coil is open or shorted | Fault state | LED will flash at a 2 Hz rate if solenoid coil is open or shorted |
| LOW AIR SUPPLY PRESSURE | Red | Supply air pressure is low | Fault state | LED will flash at a 2 Hz rate if supply air pressure is <40 psi |
| STUCK SPOOL / PILOT | Red | Solenoid valve will not shift | Fault state | LED will flash at a 2 Hz rate if solenoid valve does not shift |
| STUCK PROCESS VALVE / ACTUATOR | Red | Valve / actuator will not turn | Fault state | LED will flash at a 2 Hz rate if valve/actuator does not turn |

LED indications

1. The OPEN green LED is lit steady when the valve is in the open position and the open position sensor is on. Input bit 3 (DI2) will be set to 1. If the valve is open and the LED is not lit, perform sensor setting procedure.
2. The CLOSED red LED is lit steady when the valve is in the closed position and the closed position sensor is on. Input bit 4 (DI3) will be set to 1. If the valve is closed and the LED is not lit, perform sensor setting procedure.
3. The SOLENOID POWER yellow LED is lit steady when output bit 3 (DO2) is set to 1 to energize the solenoid
4. The BAD SOLENOID COIL red LED will flash at a 2 Hz rate if the solenoid pilot valve coil windings are either open or shorted. The peripheral Fault bit will be set to 1. Fault indication will clear when solenoid pilot valve is replaced.
5. The LOW AIR SUPPLY PRESSURE red LED will flash at a 2 Hz rate if the supply pressure drops below 40 psi. Input bit 1 (DI 0) will be set to 1. Fault indication will clear when supply pressure goes back above 40 psi.
6. The STUCK SPOOL/PILOT red LED will flash at a 2 Hz rate if after 5 seconds* of power being applied to the coil, the internal porting pressure does not rise above 10 psi. Conversely, if after 5 seconds* of power being removed from the coil and the internal porting pressure does not drop below 30 psi, a STUCK SPOOL/PILOT fault will be indicated. For either condition, the peripheral Fault bit will be set to 1. Fault indication will remain active until internal porting pressure requirements are met.
7. The STUCK PROCESS VALVE/ACTUATOR red LED will flash at a 2 Hz rate if after 5 seconds* of power being applied to or removed from the coil, the valve/actuator does not move by a minimum of 10% of stroke, provided there is not a STUCK SPOOL/PILOT or LOW AIR SUPPLY PRESSURE fault already indicated. Input bit 2 (DI 1) will be set to 1.
A STUCK PROCESS VALVE/ACTUATOR fault will also be indicated if the valve/actuator does not reach the commanded position within 20 seconds* (valve open position when solenoid coil is energized or valve closed position when solenoid coil is de-energized). This is also referred to as a stroke time alarm. Input bit 2 (DI 1) will be set to 1.

Note

* The factory default time settings of the stroke time alarm circuit is 20 seconds for valve full stroke time and 5 seconds for the STUCK SPOOL/PILOT and the STUCK PROCESS VALVE/ACTUATOR diagnostic functions. The stroke time alarm circuit timing is manually adjustable from 1 to 60 seconds. When manually setting the full stroke time, the secondary timing used in the STUCK SPOOL/PILOT and the STUCK PROCESS VALVE/ACTUATOR diagnostic functions is fixed to one half the time period of the full stroke time.

For example: if full stroke time is set to 30 seconds, the time out for the STUCK SPOOL/PILOT and the STUCK PROCESS VALVE/ACTUATOR diagnostic functions will be 15 seconds.

4.2 Valve communication terminals (VCT)

4.2.7 VCT with AS-Interface communication and extended addressing (97S)

| Specifications | | | | | | | | | | | |
|------------------------|--|--------|---------|---------------------|------------------|---------------------|---------------|-------------------|---------------|-----------------|-----------------------|
| Communication protocol | AS-Interface v3.0 | | | | | | | | | | |
| Configuration | (2) Discrete inputs (sensors) (2) Auxiliary discrete inputs (2) Discrete outputs (solenoid) | | | | | | | | | | |
| Input voltage | 26.5-31.6 VDC (AS-I voltage) | | | | | | | | | | |
| Output voltage | 24 VDC (+/- 10%) | | | | | | | | | | |
| Quiescent current | 21 mA | | | | | | | | | | |
| Current Consumption | 42 mA - 0.5 w coil (D) | | | | | | | | | | |
| Maximum output current | 100 mA (2 watts) | | | | | | | | | | |
| Default address | 0A | | | | | | | | | | |
| ID/IO codes | ID = A; IO = 7; ID1 = F; ID2 = E (S-7.A.E.) | | | | | | | | | | |
| Bit assignment | <table border="0"> <tr> <td>Inputs</td> <td>Outputs</td> </tr> <tr> <td>Bit 0 = Aux input 1</td> <td>Bit 0 = Not used</td> </tr> <tr> <td>Bit 1 = Aux input 2</td> <td>Bit 1 = OUT 2</td> </tr> <tr> <td>Bit 2 = Green LED</td> <td>Bit 2 = OUT 1</td> </tr> <tr> <td>Bit 3 = Red LED</td> <td>Bit 3 = Not available</td> </tr> </table> | Inputs | Outputs | Bit 0 = Aux input 1 | Bit 0 = Not used | Bit 1 = Aux input 2 | Bit 1 = OUT 2 | Bit 2 = Green LED | Bit 2 = OUT 1 | Bit 3 = Red LED | Bit 3 = Not available |
| Inputs | Outputs | | | | | | | | | | |
| Bit 0 = Aux input 1 | Bit 0 = Not used | | | | | | | | | | |
| Bit 1 = Aux input 2 | Bit 1 = OUT 2 | | | | | | | | | | |
| Bit 2 = Green LED | Bit 2 = OUT 1 | | | | | | | | | | |
| Bit 3 = Red LED | Bit 3 = Not available | | | | | | | | | | |

WARNING

Do not apply external power to the output terminals. This will cause permanent damage to the unit.

Bench test procedure and sensor setting instructions

To test sensors, use a 24 VDC power supply. No series load resistor is required.

1. Apply power across the ASi+ and ASi- terminal points.
2. Operate actuator to the closed position.
3. Press and hold SET CLOSED button until CLOSED LED is lit (2 seconds). Release button.
4. Operate actuator to the open position.
5. Press and hold SET OPEN button until OPEN LED is lit (2 seconds). Release button.

Setpoints are retained even after power is removed. A functioning AS-Interface network is required to test communications.

Wiring diagram

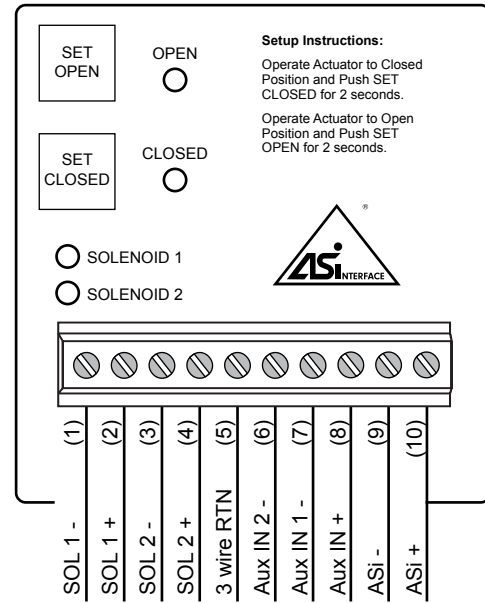

Common receptacle options pin-out

4-PIN MICRO CONNECTOR (M12)

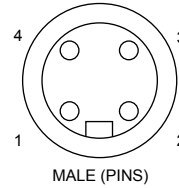

| Pin | Signal |
|-----|----------|
| 1 | ASi + |
| 2 | not used |
| 3 | ASi - |
| 4 | not used |

4-PIN MINI CONNECTOR

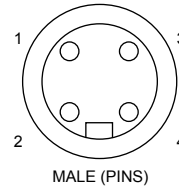

4.2 Valve communication terminals (VCT)

4.2.8 VCT with AS-Interface with Wireless Link (96W & 97W)

| Specifications for AS-Interface VCT module | | | | | | | | | | | |
|--|--|--------|---------|---------------------|--------------------------|---------------------|---------------|-------------------|---------------|-----------------|-----------------------|
| Communication protocol | AS-Interface v3.0 | | | | | | | | | | |
| Configuration | (2) Discrete inputs (sensors) (2) Auxiliary discrete inputs (2) Discrete outputs (solenoids) | | | | | | | | | | |
| Input voltage | 26.5-31.6 VDC (AS-I voltage) | | | | | | | | | | |
| Output voltage | 24 VDC (+/- 10%) | | | | | | | | | | |
| Quiescent current | 21 mA | | | | | | | | | | |
| Current Consumption | 42 mA - 0.5 w coil (D) | | | | | | | | | | |
| Maximum output current | 170 mA (4 watts; both outputs combined) | | | | | | | | | | |
| Specifications unique to 96W | | | | | | | | | | | |
| Default address | 00 | | | | | | | | | | |
| ID/IO codes | ID = F; IO = 4; ID1 = F; ID2 = E (S.7.F.E.) | | | | | | | | | | |
| Bit assignment | <table border="0"> <tr> <td>Inputs</td> <td>Outputs</td> </tr> <tr> <td>Bit 0 = Aux input 1</td> <td>Bit 0 = Control override</td> </tr> <tr> <td>Bit 1 = Aux input 2</td> <td>Bit 1 = Wink</td> </tr> <tr> <td>Bit 2 = Green LED</td> <td>Bit 2 = OUT 1</td> </tr> <tr> <td>Bit 3 = Red LED</td> <td>Bit 3 = OUT 2</td> </tr> </table> | Inputs | Outputs | Bit 0 = Aux input 1 | Bit 0 = Control override | Bit 1 = Aux input 2 | Bit 1 = Wink | Bit 2 = Green LED | Bit 2 = OUT 1 | Bit 3 = Red LED | Bit 3 = OUT 2 |
| Inputs | Outputs | | | | | | | | | | |
| Bit 0 = Aux input 1 | Bit 0 = Control override | | | | | | | | | | |
| Bit 1 = Aux input 2 | Bit 1 = Wink | | | | | | | | | | |
| Bit 2 = Green LED | Bit 2 = OUT 1 | | | | | | | | | | |
| Bit 3 = Red LED | Bit 3 = OUT 2 | | | | | | | | | | |
| Specifications unique to 97W | | | | | | | | | | | |
| Default address | 0A | | | | | | | | | | |
| ID/IO codes | ID = A; IO = 7; ID1 = F; ID2 = E (S.7.A.E.) | | | | | | | | | | |
| Bit assignment | <table border="0"> <tr> <td>Inputs</td> <td>Outputs</td> </tr> <tr> <td>Bit 0 = Aux input 1</td> <td>Bit 0 = Control override</td> </tr> <tr> <td>Bit 1 = Aux input 2</td> <td>Bit 1 = out 2</td> </tr> <tr> <td>Bit 2 = green LED</td> <td>Bit 2 = out 1</td> </tr> <tr> <td>Bit 3 = red LED</td> <td>Bit 3 = not available</td> </tr> </table> | Inputs | Outputs | Bit 0 = Aux input 1 | Bit 0 = Control override | Bit 1 = Aux input 2 | Bit 1 = out 2 | Bit 2 = green LED | Bit 2 = out 1 | Bit 3 = red LED | Bit 3 = not available |
| Inputs | Outputs | | | | | | | | | | |
| Bit 0 = Aux input 1 | Bit 0 = Control override | | | | | | | | | | |
| Bit 1 = Aux input 2 | Bit 1 = out 2 | | | | | | | | | | |
| Bit 2 = green LED | Bit 2 = out 1 | | | | | | | | | | |
| Bit 3 = red LED | Bit 3 = not available | | | | | | | | | | |
| Specifications for Wireless Link | | | | | | | | | | | |
| Communication | Bluetooth® Smart technology; single mode (not compatible with Bluetooth® Classic) | | | | | | | | | | |
| Transmit power | 4dBm or ~2.5 milliwatts | | | | | | | | | | |
| Data rate | 1 Mbit/second; effective information transmit rate ~10 Kbits/second | | | | | | | | | | |
| Range | Up to 100 meters (330 feet) in free space. Range is reduced by obstructions between hand-held device and Wireless Link VCT. Line of site is not necessary. | | | | | | | | | | |
| Registrations | FCC, IC, CE | | | | | | | | | | |
| CE compliance | Exceeds industrial compliance standards | | | | | | | | | | |
| VCT identification | VCTs in range will be displayed | | | | | | | | | | |
| VCT link | One device accessed at a time between client (hand-held device) and server (VCT). Each server accessed by one client at a time | | | | | | | | | | |
| Application | StoneL Wireless Link available from the App store | | | | | | | | | | |
| Handhelds | Compatible with iPhone® and iPad® with iOS 8 or later | | | | | | | | | | |

Wiring diagram

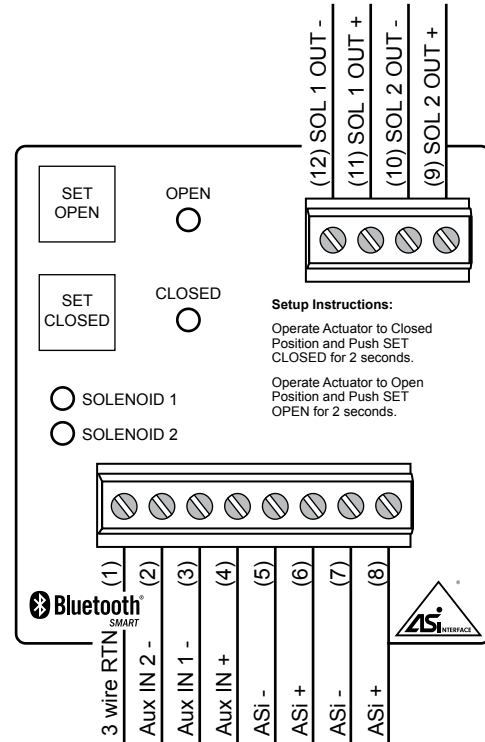

Setup Instructions:
Operate Actuator to Closed Position and Push SET CLOSED for 2 seconds.
Operate Actuator to Open Position and Push SET OPEN for 2 seconds.

Common receptacle options pin-out

4-PIN MICRO CONNECTOR (M12)

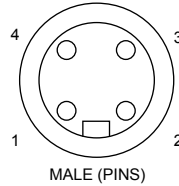

MALE (PINS)

4-PIN MINI CONNECTOR

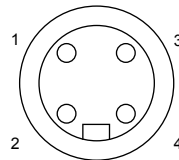

MALE (PINS)

| Pin | Signal |
|-----|----------|
| 1 | ASi + |
| 2 | not used |
| 3 | ASi - |
| 4 | not used |

WARNING

Do not apply external power to the output terminals. This will cause permanent damage to the unit.

Bench test procedure and sensor setting instructions

To test sensors, use a 24 VDC power supply. No series load resistor is required.

1. Apply power across the ASi+ and ASi- terminal points.
2. Operate actuator to the closed position.
3. Press and hold SET CLOSED button until CLOSED LED is lit (2 seconds). Release button.
4. Operate actuator to the open position.
5. Press and hold SET OPEN button until OPEN LED is lit (2 seconds). Release button.

Setpoints are retained even after power is removed. A functioning AS-Interface network is required to test communications.

5 Wireless Link user guide

5.1 Getting started

Before using this guide, ensure that you have downloaded the most current version of the StoneL Wireless Link app to your iPhone® or iPad® from the App Store. It is an iPhone® app but designed to work with an iPad® as well. When searching the App Store on an iPad®, ensure that the drop-down menu at the top of search results page is set to "iPhone Only." Your iOS device must be running iOS 8 or later and be equipped with *Bluetooth*® technology to use the StoneL Wireless Link app. The app is not compatible with *Bluetooth*® Classic.

Make sure that your iOS device has its *Bluetooth*® capability turned on when attempting to use the StoneL Wireless Link app. This can be found under your iOS device's settings. To ensure that you have good *Bluetooth*® reception, keep your iOS device within 33 ft [10 m] of the module that you wish to connect to. The range of your *Bluetooth*® device may be affected by many things, including interference from other devices and physical obstructions.

WARNING

Upon disconnect or master disabling overrides, output forces will be removed and valve may cycle.

5.2 Home screen

Selecting a valve

After opening the StoneL Wireless Link app, you are directed to the home screen. This screen allows you to browse and select a specific automated valve when multiple valves are present.

1. All energized wireless modules within range of your iOS device will appear on the screen (Image 1). If no powered devices are within range, the device list will be blank.
2. To identify a specific valve when multiple valves are present, select the wink button next to the unit you wish to select (Item A). This will cause the module's LEDs to blink for 30 seconds, or until you press the "Stop Winking" button (Item B)
3. Choose a specific valve by selecting the row that relates to the unit you wish to select (Item C), this will direct you to the device detail screen.

Note

The list of devices present can be refreshed by swiping downward on the home screen.

Releasing a device

Once you have selected a device, it will be paired to your Apple device until you unpair it.

1. In order for another Apple device user to access control with their wireless link app, unpair your device by going back to the home screen/device list.

Menu

Selecting the menu (Item D) on the upper left corner of the home screen allows you access import and export features (Image 2).

1. The device list import allows you to import: valve tag number, device address, baud rate (if applicable), valve/actuator description and additional information from a CSV file.
2. The device list export allows you to export: valve tag number, device address, baud rate (if applicable), valve/actuator description, valve position, stroke time, cycle count data, and additional information to a CSV file.

5.3 Locked screen

If the icons on the device detail screen appear grayed-out or unavailable to select, this means the master is still in control. (Image 3) Check to ensure that the power supply is set to IR addressing mode (AS-i only) or enable the control override bit for the device (AS-i DO Bit 2; DeviceNet™ Byte 0, Bit 7).

Image 1

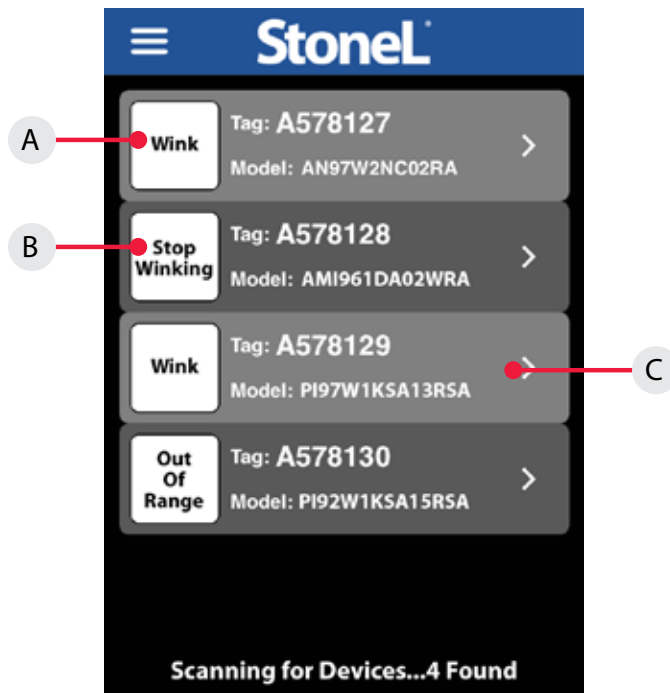
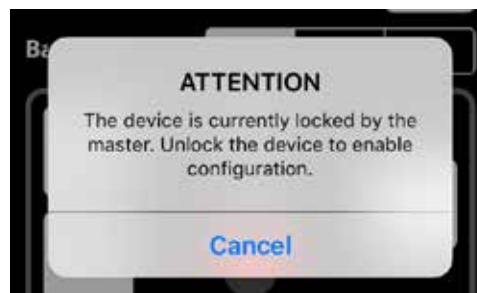

Image 2



Image 3



5.4 Device detail screen

You can customize the tag for a device, change the address, change the baud rate (if applicable), force the solenoids on or off, cause the device to wink, and set the open/closed limits from the device detail screen (Image 4a or 4b).

Changing the device tag or address on a DeviceNet unit

- To change the tag, edit the existing tag in the associated text field (Item E). The tag can be up to sixteen characters long.
- To change the DeviceNet address, edit the existing address in the associated text field (Item G). The DeviceNet address for the 92W can be 1 to 63
 - When changing the address, a warning screen will appear indicating this action could disrupt the process. Select cancel or continue.
 - Select continue and alter the address via number pad and select done. A warning screen will appear indicating the choice to reset now or reset later. Resetting the device could disrupt the process.
 - Selecting reset now will implement the address change of the device.
 - Selecting reset later will not implement device address change until selecting reset slave (Item F) and will cause the device address to indicate pending status.
- To change the device baud rate (Item H), select the desired rate from the choices. The device default baud rate is 125K.
 - When changing the baud rate, a warning screen will appear indicating this action could disrupt the process. Select reset now or reset later.
 - Selecting reset now will implement the change to the baud rate of the device.
 - Selecting reset later will not implement the change to the baud rate of the device until selecting reset slave.
- Selecting reset slave will cause a warning screen to appear indicating resetting the device could disrupt the process. Select continue to implement changes made to the device address and/or device baud rate.

Changing the device tag or address on an ASi unit

- To change the tag, edit the existing tag in the associated text field (Item M). The tag can be up to sixteen characters long.
- To change the AS-i address, edit the existing address in the associated text field (Item N). The AS-i address for the 97W can be 0A to 31A or 0B to 31B.
 - When changing the address, a warning screen will appear indicating this action could disrupt the process. Select cancel or continue.
 - Select continue and alter the address via number pad and select done.

Forcing the solenoids on/off

Forcing a solenoid on or off will override master control if wireless link overrides are enabled.

- The solenoid control state is forced on or forced off when it is highlighted in orange (Item J).
 - Warning screen will appear indicating this action could disrupt the process. Select cancel or continue.
 - Select continue and when a solenoid is on, a yellow light will illuminate next to the solenoid (Item K).
 - Select continue and when a solenoid is off, no light will illuminate next to the solenoid (Item L).

Image 4a - DeviceNet detail

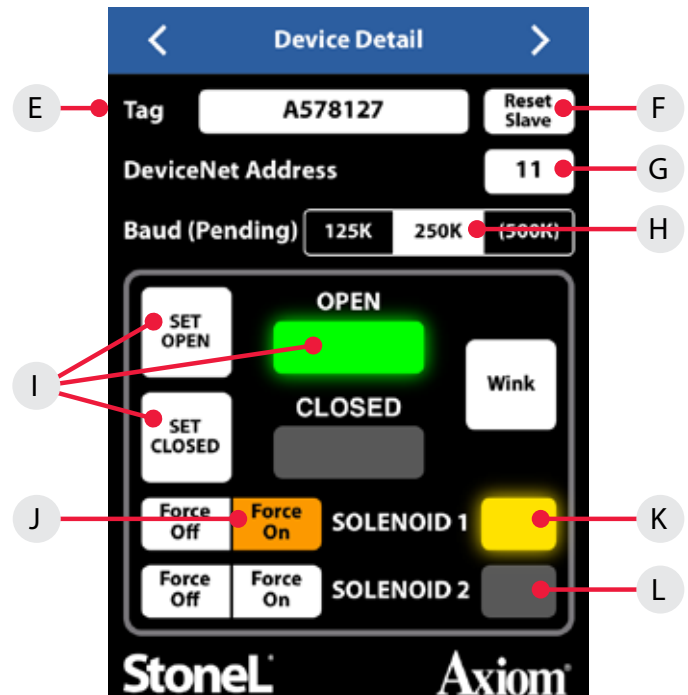

Image 4b - ASi detail



Setting the valve position

Forcing the solenoid on and off is one way of actuating the valve when setting the open and closed positions.

- To set a valve to the closed position:
 - Actuate the valve to the CLOSED position. This can be done by forcing the solenoid(s) on or off.
 - Select set closed. A warning screen will appear indicating this action could disrupt the process. Select cancel or continue.
 - Select continue and the red closed light will illuminate (Item I).
 - The valve now remembers the current position as the closed position.
- To set a valve to the open position:
 - Actuate the valve to the OPEN position. This can be done by forcing the solenoid(s) on or off.
 - Select set open. A warning screen will appear indicating this action could disrupt the process. Select cancel or continue.
 - Select continue and the green open light will illuminate (Item I).
 - The valve now remembers the current position as the open position.

5.5 More information screen

To see additional information about a specific valve, swipe right or use the arrows at the top of the device detail screen.

1. At the top of the more Information screen (Image 5), the Axiom model number, serial number, and date code are displayed (Item O). These are preset from the factory and cannot be changed.
2. There are two customizable text boxes titled "Valve/Actuator Description" and "Additional Information" where up to 160 characters can be added for user notes, such as maintenance or service records (Item P).

Website and instruction manual

The direct links to Stonel's website and the Axiom AX Installation, Maintenance and Operating Instructions located on the bottom buttons of the More Information screen require an internet connection to access (Item Q).

5.6 Diagnostics screen

To see additional diagnostics about a specific valve, advance a page to the right using the arrows at the top of the more information screen.

1. The valve position information includes real time valve position, stroke time baseline, and stroke time of last cycle (Item R).
2. The valve cycle count is displayed and indicates how many cycles the valve has made since last reset (Item S). A cycle is considered to be a complete actuation of the valve. Selecting the reset button (Item U) will erase the cycle count and start counting again from 0.
3. The current temperature of the valve monitor is displayed; along with the temperature range of the valve since last reset (Item T). Selecting the reset button (Item V) will erase the historical temperature data and start a new period of temperature data collection.
4. If an external 4-20mA loop powered device is connected to the auxiliary analog input of the module, the feedback signal can be monitored here. (DeviceNet only - Item W)
5. If external switches are connected to the Aux 1 or Aux 2 inputs of the module, these switches can be monitored here. (AS-i only - Item Y)
6. The Error Status register (Item X) can display numerous faults that are detected by the module. This data is only available via the Wireless Link app and is not accessible from the bus network. The following is a list of errors/faults that can be detected and display on the iOS device:

| Error status register | | |
|-----------------------|--------------------------|------------------|
| Common | DeviceNet only | ASi only |
| Output shorted | Major DeviceNet fault | No data exchange |
| Internal sensor fault | Minor DeviceNet fault | |
| No magnet detected | DeviceNet timed-out | |
| Bus protocol error | Pending DeviceNet change | |
| | Duplicate address | |
| | Bus-off fault | |

Image 5

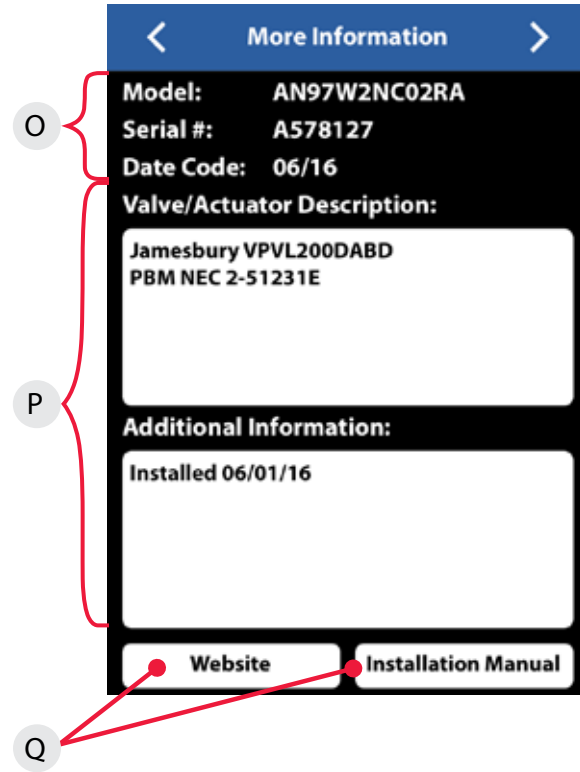

Image 6a - DeviceNet detail

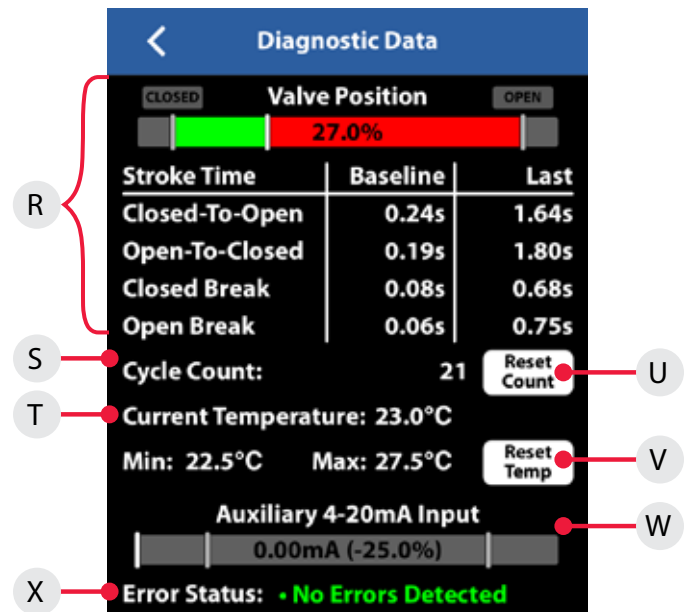

Image 6b - ASi detail



5.7 Federal Communication Commission (FCC) statement

This device complies with Part 15 of the FCC Rules. Operation is subject to the following two conditions:

1. This device may not cause harmful interference.
2. This device must accept any interference received, including interference that may cause undesired operation.

Note

This equipment has been tested and found to comply with the limits for a Class B digital device, pursuant to Part 15 of the FCC Rules. These limits are designed to provide reasonable protection against harmful interference in a residential installation. This equipment generates, uses, and can radiate radio frequency energy and, if not installed and used in accordance with the instructions, may cause harmful interference to radio communications. However, there is no guarantee that interference will not occur in a particular installation. If this equipment does cause harmful interference to radio or television reception, which can be determined by turning the equipment off and on, the user is encouraged to correct the interference by one or more of the following measures:

- Re-orient or relocate the receiving antenna
- Increase the separation between the equipment and the receiver
- Connect the equipment to an outlet on a circuit that is different from that to which the receiver is connected.
- Consult the dealer or an experienced radio/TV technician for help.

Contains FCC ID: PI4BL600



Caution: Any changes or modifications not expressly approved by the party responsible for compliance could void the user's authority to operate the equipment.

FCC Radiation Exposure Statement

This equipment is in compliance with SAR for general population/uncontrolled exposure limits in ANSI/IEEE C95.1-1999 and had been tested in accordance with the measurement methods and procedures specified in OET Bulletin 65 Supplement C.

This transmitter must not be co-located or operating in conjunction with any other antenna or transmitter

6 Model/Type code

| Model selector | | | |
|---|---|--|--|
| SERIES | | | |
| AMI | Nonincendive or intrinsically safe | | |
| FUNCTIONS | | | |
| Sensor modules | | Valve communication Terminals (VCTs) | |
| 33 | SST NO sensor | 71 | 4-20 mA with HART diagnostics |
| 35 | SST 240V Universal (NO sensor) | 92 | DeviceNet™ |
| 44 | NAMUR sensors intrinsically safe (EN 60947-5-6; I.S.) | 93 | Foundation Fieldbus (bus powered; I.S.) |
| 80 | Expeditor | 94 | Foundation Fieldbus (externally powered) |
| | | 96 | AS-Interface |
| | | 97 | AS-Interface with extended addressing |
| PNEUMATIC VALVE | | | |
| No external override | | External override | Latching external override |
| 1H | Single pilot, universal voltage solenoid | 3H | Single pilot, universal voltage solenoid |
| 1J | Single pilot, 240 VAC (4.5 watts) | 3J | Single pilot, 240 VAC (4.5 watts) |
| 1D | Single pilot, 24 VDC (0.5 watt) | 3D | Single pilot, 24 VDC (0.5 watt) |
| 1E | Single pilot, 12 VDC intrinsically safe | 3E | Single pilot, 12 VDC intrinsically safe |
| 1B | Single pilot, 1.8 W 24 VDC | 3B | Single pilot, 1.8 W 24 VDC |
| 2H | Dual pilot, universal voltage solenoid | 4H | Dual pilot, universal voltage solenoid |
| 2J | Dual pilot, 240 VAC (4.5 watts) | 4J | Dual pilot, 240 VAC (4.5 watts) |
| 2D | Dual pilot, 24 VDC (0.5 watt) | 4D | Dual pilot, 24 VDC (0.5 watt) |
| 2E | Dual pilot, 12 VDC intrinsically safe | 4E | Dual pilot, 12 VDC intrinsically safe |
| 2B | Dual pilot, 1.8 W 24 VDC | 4B | Dual pilot, 1.8 W 24 VDC |
| 1A | Single piezo, intrinsically safe or standard | 3A | Single piezo, intrinsically safe or standard |
| 2A | Dual piezo, intrinsically safe or standard | 4A | Dual piezo, intrinsically safe or standard |
| | | 5A | Single piezo, intrinsically safe or standard |
| ENCLOSURE | | | |
| A | North American (NEC/CEC) | L | Brazilian |
| V | International (IEC) | E | Aluminum cover |
| CONDUIT/CONNECTORS | | | |
| Standard | | Mini-connectors | Micro-connectors |
| 02 | (2) ½ in NPT | 10 | (1) 4-pin |
| 05 | (2) M20 | 11 | (1) 5-pin |
| | | 19 | (1) 6-pin |
| | | 20 | (1) 7-pin |
| | | 21 | (1) 8-pin |
| CAPABILITIES | | | |
| S | Standard | | |
| D | Diagnostics | | |
| W | Wireless Link | | |
| VISUAL INDICATOR | | | |
| R | Red closed/green open | 1 | Three-way flow path |
| G | Green closed/red open | 2 | Three-way flow path |
| | | X | Special |
| BRANDING | | | |
| A | Stonel | | |
| M | Metso | | |
| Model number example | | | |
| AMI | 96 | 1B | A |
| | | | 02 |
| | | | W |
| | | | R |
| | | | M |
| | | | - |
| | | | OPTIONAL |
| | | | OR |
| | | | -T |
| MODEL NUMBER | | PARTNERSHIP ID | TEMPERATURE* |
| Mounting hardware required and sold separately. | | Some models may include 5-digit identification suffix. | Specify -T suffix for extended temperature. |
| | | | *Special notes |
| | | | Extended temperature range for function "80" (Expeditor): -20°C to 80°C. Extended temperature is not an option for Function 93 and Piezo |

7 Regulatory, specific conditions of use, and product marking



DECLARATION OF CONFORMITY

Manufacturer:

StoneL
26271 US Highway 59
Fergus Falls, Minnesota 56537 USA

Products:

Axiom AMI Series – Valve Position Monitors and Valve Communication Terminals

| Model - Type | Certificates / Directives / Standards | Marking |
|--------------|---|---|
| AMI Series | EU Type Examination Certificate FM08ATEX0040X ATEX 2014/34/EU EN 60079-0:2012+A11:2013, EN 60079-15:2010, EN 60079-18:2015 EMC 2014/30/EU EN 60947-5-2:2007/A1:2012 EN 62026-2:2013, EN 62026-3:2009 |  ATEX II 3 G Ex nA mc IIC T5 Gc |
| AMI Series | EU Type Examination Certificate FM07ATEX0047X ATEX 2014/34/EU EN 60079-0:2012+A11:2013, EN 60079-11:2012 EMC 2014/30/EU EN 60947-5-2:2007/A1:2012 EN 62026-2:2013, EN 62026-3:2009 |  ATEX II 1 G Ex ia IIC T5 Ga |
| AMI Series | EMC 2014/30/EU EN 60947-5-2:2007/A1:2012 EN 62026-2:2013, EN 62026-3:2009 |  |

ATEX Notified Bodies for EU Type Examination Certificates:

FM Approvals Ltd. Windsor, Berkshire, UK (Notified Body Number 1725)

Quality Assurance Certificates:

ISO 9001:2008.....TUV SUD America Inc.
QAN FM06ATEXQ0013.....FM Approvals (Notified Body Number 1725)
QAR GB/FME/QAR11.0003.....FM Approvals (Notified Body Number 1725)

We declare under our sole responsibility that the products, as described, are in conformity with the listed standards and directives.

Fergus Falls, 1st June 2017



Bryan Beckman, Quality Manager
Authorized Person of the Manufacturer

7 Regulatory, specific conditions of use, and product marking continued

SPECIFIC CONDITIONS OF USE / MARKING

| For AMI Series – FM08ATEX0040X | |
|---|---|
| Specific Conditions of Use | Marking |
| <p>1. On installation the AMI Series Valve Position Monitor shall be provided with supply transient protection external to the apparatus such that the voltage at the supply terminals of the AMI Series Valve Position Monitor does not exceed 140% of the voltage rating of the equipment.</p> <p>2. The plastic cover of the apparatus may constitute an electrostatic hazard. Clean only with a damp cloth.</p> | <p>ATEX II 3 G Ex nA mc IIC T5 Gc Ta = -18°C to +50°C ATEX II 3 G Ex nA mc IIC T5 Gc Ta = -10°C to +60°C ATEX II 3 G Ex nA mc IIC T5 Gc Ta = -40°C to +70°C</p> |
| For AMI Series – FM07ATEX0047X | |
| Specific Conditions of Use - Notes | Marking |
| <p>1. When used within a Zone 0 location, the aluminum enclosure shall be installed in such a manner as to prevent the possibility of sparks resulting from friction or impact.</p> <p>2. To prevent the risk of electrostatic sparking, the equipment enclosure shall be cleaned only with a damp cloth.</p> | <p>ATEX II 1 G Ex ia IIC T5 Ga Ta = -40°C to +80°C ATEX II 1 G Ex ia IIC T5 Ga Ta = -18°C to +50°C</p> |

8 Appendix

8.1 Controlled installation drawings

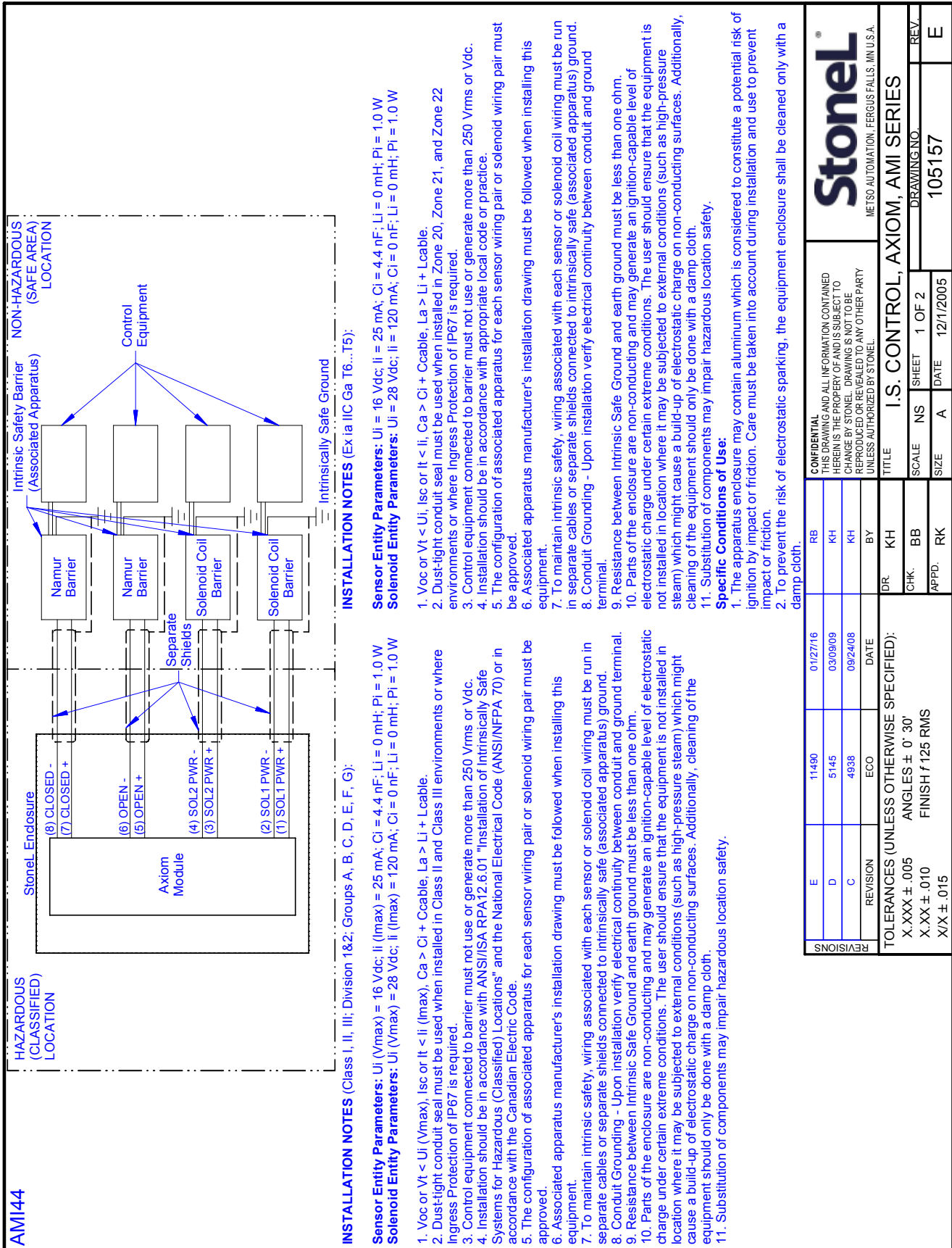

AMI144

HAZARDOUS (CLASSIFIED) LOCATION

NON-HAZARDOUS (SAFE AREA) LOCATION

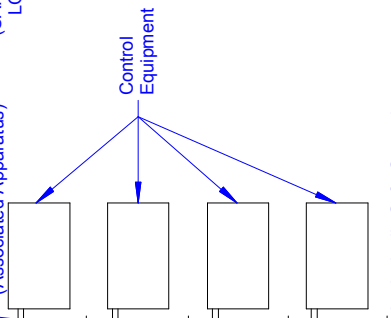
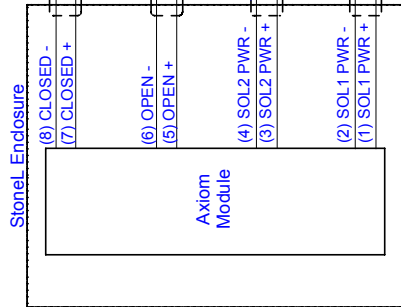

INSTALLATION NOTES (Class I, II, III; Division 1&2; Groups A, B, C, D, E, F, G):

Sensor Entity Parameters: U_i (Vmax) = 16 Vdc; i_i (Imax) = 25 mA; C_i = 4.4 nF; L_i = 0 mH; P_i = 1.0 W
Solenoid Entity Parameters: U_i (Vmax) = 28 Vdc; i_i (Imax) = 120 mA; C_i = 0 nF; L_i = 0 mH; P_i = 1.0 W

1. V_{oc} or $V_t < U_i$ (Vmax), I_{sc} or $I_t < i_i$ (Imax), $C_a > C_i$ + Ccable, $L_a > L_i$ + Lcable.
2. Dust-tight conduit seal must be used when installed in Class II and Class III environments or where Ingress Protection of IP67 is required.
3. Control equipment connected to barrier must not use or generate more than 250 Vrms or Vdc.
4. Installation should be in accordance with ANSI/ISA RPA12.6.01 "Installation of Intrinsically Safe Systems for Hazardous (Classified) Locations" and the National Electrical Code (ANSI/NFPA 70) or in accordance with the Canadian Electric Code.
5. The configuration of associated apparatus for each sensor wiring pair or solenoid wiring pair must be approved.
6. Associated apparatus manufacturer's installation drawing must be followed when installing this equipment.
7. To maintain intrinsic safety, wiring associated with each sensor or solenoid coil wiring must be run in separate cables or separate shields connected to intrinsically safe (associated apparatus) ground.
8. Conduit Grounding - Upon installation verify electrical continuity between conduit and ground terminal.
9. Resistance between Intrinsic Safe Ground and earth ground must be less than one ohm.
10. Parts of the enclosure are non-conducting and may generate an ignition-capable level of electrostatic charge under certain extreme conditions. The user should ensure that the equipment is not installed in location where it may be subjected to external conditions (such as high-pressure steam) which might cause a build-up of electrostatic charge on non-conducting surfaces. Additionally, cleaning of the equipment should only be done with a damp cloth.
11. Substitution of components may impair hazardous location safety.

Sensor Entity Parameters: U_i = 16 Vdc; i_i = 25 mA; C_i = 4.4 nF; L_i = 0 mH; P_i = 1.0 W
Solenoid Entity Parameters: U_i = 28 Vdc; i_i = 120 mA; C_i = 0 nF; L_i = 0 mH; P_i = 1.0 W

1. V_{oc} or $V_t < U_i$, I_{sc} or $I_t < i_i$, $C_a > C_i$ + Ccable, $L_a > L_i$ + Lcable.
2. Dust-tight conduit seal must be used when installed in Zone 20, Zone 21, and Zone 22 environments or where Ingress Protection of IP67 is required.
3. Control equipment connected to barrier must not use or generate more than 250 Vrms or Vdc.
4. Installation should be in accordance with appropriate local code or practice.
5. The configuration of associated apparatus for each sensor wiring pair or solenoid wiring pair must be approved.
6. Associated apparatus manufacturer's installation drawing must be followed when installing this equipment.
7. To maintain intrinsic safety, wiring associated with each sensor or solenoid coil wiring must be run in separate cables or separate shields connected to intrinsically safe (associated apparatus) ground.
8. Conduit Grounding - Upon installation verify electrical continuity between conduit and ground terminal.
9. Resistance between Intrinsic Safe Ground and earth ground must be less than one ohm.
10. Parts of the enclosure are non-conducting and may generate an ignition-capable level of electrostatic charge under certain extreme conditions. The user should ensure that the equipment is not installed in location where it may be subjected to external conditions (such as high-pressure steam) which might cause a build-up of electrostatic charge on non-conducting surfaces. Additionally, cleaning of the equipment should only be done with a damp cloth.
11. Substitution of components may impair hazardous location safety.

Specific Conditions of Use:

1. The apparatus enclosure may contain aluminum which is considered a potential risk of ignition by impact or friction. Care must be taken into account during installation and use to prevent impact or friction.
2. To prevent the risk of electrostatic sparking, the equipment enclosure shall be cleaned only with a damp cloth.

| | | | |
|---|---------|--|--------|
| CONFIDENTIAL THIS DRAWING AND ALL INFORMATION CONTAINED HEREIN IS THE PROPERTY OF AND IS SUBJECT TO CHANGE BY STONEL. DRAWING IS NOT TO BE REPRODUCED OR REVEALED TO ANY OTHER PARTY UNLESS AUTHORIZED BY STONEL. | | Stonel METSO AUTOMATION, FERGUS FALLS, MN U.S.A. | |
| TITLE: I.S. CONTROL, AXIOM, AMI SERIES | | DRAWING NO. 105157 | |
| DR: KH | NS | SHEET 1 OF 2 | REV. E |
| CHK: BB | SCALE A | DATE 12/1/2005 | |
| APPD: RK | SIZE | | |
| TOLERANCES (UNLESS OTHERWISE SPECIFIED): X.XXX ± 0.005 ANGLES ± 0° 30' X.XX ± 0.010 FINISH f 125 RMS X/X ± .015 | | | |
| REVISIONS | 11490 | 01/27/16 | RB |
| D | 5145 | 03/09/09 | KH |
| C | 4938 | 09/24/08 | KH |
| REVISION | ECO | DATE | BY |

8.1 Controlled installation drawings continued

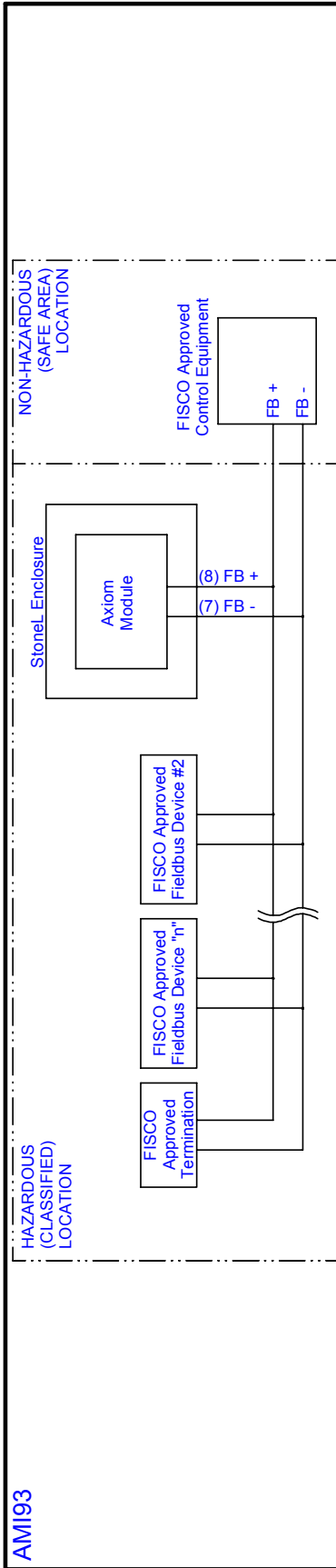

AMI93

INSTALLATION NOTES (Class I, II, III; Division 1&2; Groups A, B, C, D, E, F, G):

Entity Parameters (FISCO): $U_i = 30 \text{ Vdc}$; $I_i(\text{max}) = 380 \text{ mA}$; $C_i = 0 \text{ nF}$; $L_i = 0 \text{ mH}$; $P_i = 5.32 \text{ W}$
Outputs: $U_o = 7.14 \text{ Vdc}$; $I_o = 47 \text{ mA}$; $P_o = 0.1 \text{ W}$

1. Installation shall be in accordance with ANSI/ISA RPT12.6.01, ANSI/NFPA 70, and the National Electrical Code or in accordance with the Canadian Electric Code.
2. Dust-tight conduit seal must be used when installed in Class II and Class III environments or where Ingress Protection of IP67 is required.
3. Control equipment must be FISCO Approved Associated Apparatus.
4. Control equipment connected to FISCO barrier must not use or generate more than 250Vrms or Vdc.
5. Resistance between FISCO Intrinsically Safe Ground and earth ground must be less than 1.0 Ohm.
6. Parts of the enclosure are non-conducting and may generate an ignition-capable level of electrostatic charge under certain extreme conditions. The user should ensure that the equipment is not installed in location where it may be subjected to external conditions (such as high-pressure steam) which might cause a build-up of electrostatic charge on non-conducting surfaces. Additionally, cleaning of the equipment should only be done with a damp cloth.
7. Substitution of components may impair hazardous location safety.
8. Approval Agency controlled Installation Diagram. No revision to diagram allowed without prior Factory Mutual or Approval Agency authority.

INSTALLATION NOTES (Ex Ia IIC T5):

Entity Parameters (FISCO): $U_i = 30 \text{ Vdc}$; $I_i = 380 \text{ mA}$; $C_i = 0 \text{ nF}$; $L_i = 0 \text{ mH}$; $P_i = 5.32 \text{ W}$
Outputs: $U_o = 7.14 \text{ Vdc}$; $I_o = 47 \text{ mA}$; $P_o = 0.1 \text{ W}$

1. Installation shall be in accordance with appropriate Electrical Code or practices.
2. Dust-tight conduit seal must be used when installed in Zone 20, Zone 21, and Zone 22 environments or where Ingress Protection of IP67 is required.
3. Control equipment must be FISCO Approved Associated Apparatus.
4. Control equipment connected to FISCO barrier must not use or generate more than 250Vrms or Vdc.
5. Resistance between FISCO Intrinsically Safe Ground and earth ground must be less than 1.0 Ohm.
6. Parts of the enclosure are non-conducting and may generate an ignition-capable level of electrostatic charge under certain extreme conditions. The user should ensure that the equipment is not installed in location where it may be subjected to external conditions (such as high-pressure steam) which might cause a build-up of electrostatic charge on non-conducting surfaces. Additionally, cleaning of the equipment should only be done with a damp cloth.
7. Substitution of components may impair hazardous location safety.
8. Approval Agency controlled Installation Diagram. No revision to diagram allowed without prior Factory Mutual or Approval Agency authority.

Specific Conditions of Use:

1. The apparatus enclosure may contain aluminum which is considered to constitute a potential risk of ignition by impact or friction. Care must be taken into account during installation and use to prevent impact or friction.
2. To prevent the risk of electrostatic sparking, the equipment enclosure shall be cleaned only with a damp cloth.

| HAZARDOUS (CLASSIFIED) LOCATION | | NON-HAZARDOUS (SAFE AREA) LOCATION | | | | | | | | | | | | | | | | | | | |
|---|----------|---|------|---|--------|---|------|---|------|----|-----|--|--|----|------|----|----------|----|----------|----|----------|
| FISCO Approved Termination | | FISCO Approved Control Equipment | | | | | | | | | | | | | | | | | | | |
| FISCO Approved Fieldbus Device #1 | | Axiom Module | | | | | | | | | | | | | | | | | | | |
| FISCO Approved Fieldbus Device #2 | | (7) FB + | | | | | | | | | | | | | | | | | | | |
| | | (8) FB + | | | | | | | | | | | | | | | | | | | |
| | | FB + | | | | | | | | | | | | | | | | | | | |
| | | FB - | | | | | | | | | | | | | | | | | | | |
| <p>INSTALLATION NOTES (Class I, II, III; Division 1&2; Groups A, B, C, D, E, F, G):</p> <p>Entity Parameters (FISCO): $U_i = 30 \text{ Vdc}$; $I_i(\text{max}) = 380 \text{ mA}$; $C_i = 0 \text{ nF}$; $L_i = 0 \text{ mH}$; $P_i = 5.32 \text{ W}$ Outputs: $U_o = 7.14 \text{ Vdc}$; $I_o = 47 \text{ mA}$; $P_o = 0.1 \text{ W}$</p> <ol style="list-style-type: none"> 1. Installation shall be in accordance with ANSI/ISA RPT12.6.01, ANSI/NFPA 70, and the National Electrical Code or in accordance with the Canadian Electric Code. 2. Dust-tight conduit seal must be used when installed in Class II and Class III environments or where Ingress Protection of IP67 is required. 3. Control equipment must be FISCO Approved Associated Apparatus. 4. Control equipment connected to FISCO barrier must not use or generate more than 250Vrms or Vdc. 5. Resistance between FISCO Intrinsically Safe Ground and earth ground must be less than 1.0 Ohm. 6. Parts of the enclosure are non-conducting and may generate an ignition-capable level of electrostatic charge under certain extreme conditions. The user should ensure that the equipment is not installed in location where it may be subjected to external conditions (such as high-pressure steam) which might cause a build-up of electrostatic charge on non-conducting surfaces. Additionally, cleaning of the equipment should only be done with a damp cloth. 7. Substitution of components may impair hazardous location safety. 8. Approval Agency controlled Installation Diagram. No revision to diagram allowed without prior Factory Mutual or Approval Agency authority. | | | | | | | | | | | | | | | | | | | | | |
| <p>INSTALLATION NOTES (Ex Ia IIC T5):</p> <p>Entity Parameters (FISCO): $U_i = 30 \text{ Vdc}$; $I_i = 380 \text{ mA}$; $C_i = 0 \text{ nF}$; $L_i = 0 \text{ mH}$; $P_i = 5.32 \text{ W}$ Outputs: $U_o = 7.14 \text{ Vdc}$; $I_o = 47 \text{ mA}$; $P_o = 0.1 \text{ W}$</p> <ol style="list-style-type: none"> 1. Installation shall be in accordance with appropriate Electrical Code or practices. 2. Dust-tight conduit seal must be used when installed in Zone 20, Zone 21, and Zone 22 environments or where Ingress Protection of IP67 is required. 3. Control equipment must be FISCO Approved Associated Apparatus. 4. Control equipment connected to FISCO barrier must not use or generate more than 250Vrms or Vdc. 5. Resistance between FISCO Intrinsically Safe Ground and earth ground must be less than 1.0 Ohm. 6. Parts of the enclosure are non-conducting and may generate an ignition-capable level of electrostatic charge under certain extreme conditions. The user should ensure that the equipment is not installed in location where it may be subjected to external conditions (such as high-pressure steam) which might cause a build-up of electrostatic charge on non-conducting surfaces. Additionally, cleaning of the equipment should only be done with a damp cloth. 7. Substitution of components may impair hazardous location safety. 8. Approval Agency controlled Installation Diagram. No revision to diagram allowed without prior Factory Mutual or Approval Agency authority. | | | | | | | | | | | | | | | | | | | | | |
| <p>Specific Conditions of Use:</p> <ol style="list-style-type: none"> 1. The apparatus enclosure may contain aluminum which is considered to constitute a potential risk of ignition by impact or friction. Care must be taken into account during installation and use to prevent impact or friction. 2. To prevent the risk of electrostatic sparking, the equipment enclosure shall be cleaned only with a damp cloth. | | | | | | | | | | | | | | | | | | | | | |
| <p>REVISIONS</p> <table border="1"> <tr> <th>REVISION</th> <th>DATE</th> </tr> <tr> <td>E</td> <td>11/490</td> </tr> <tr> <td>D</td> <td>5145</td> </tr> <tr> <td>C</td> <td>4938</td> </tr> <tr> <td>BY</td> <td>ECO</td> </tr> </table> | | REVISION | DATE | E | 11/490 | D | 5145 | C | 4938 | BY | ECO | <p>RB</p> <table border="1"> <tr> <th>RB</th> <th>DATE</th> </tr> <tr> <td>RB</td> <td>01/27/16</td> </tr> <tr> <td>RH</td> <td>03/09/09</td> </tr> <tr> <td>RH</td> <td>09/24/08</td> </tr> </table> | | RB | DATE | RB | 01/27/16 | RH | 03/09/09 | RH | 09/24/08 |
| REVISION | DATE | | | | | | | | | | | | | | | | | | | | |
| E | 11/490 | | | | | | | | | | | | | | | | | | | | |
| D | 5145 | | | | | | | | | | | | | | | | | | | | |
| C | 4938 | | | | | | | | | | | | | | | | | | | | |
| BY | ECO | | | | | | | | | | | | | | | | | | | | |
| RB | DATE | | | | | | | | | | | | | | | | | | | | |
| RB | 01/27/16 | | | | | | | | | | | | | | | | | | | | |
| RH | 03/09/09 | | | | | | | | | | | | | | | | | | | | |
| RH | 09/24/08 | | | | | | | | | | | | | | | | | | | | |
| <p>TOLERANCES (UNLESS OTHERWISE SPECIFIED):</p> <p>X.XXX ± .005 ANGLES ± 0° 30'</p> <p>X.XX ± .010 FINISH f 125 RMS</p> <p>X/X ± .015</p> | | <p>DR. KH</p> <p>CHK. BB</p> <p>APPD. RK</p> | | | | | | | | | | | | | | | | | | | |
| <p>CONFIDENTIAL THIS DRAWING AND ALL INFORMATION CONTAINED HEREIN IS THE PROPERTY OF AND IS SUBJECT TO CHANGE BY STONEL. DRAWING IS NOT TO BE REPRODUCED OR REVEALED TO ANY OTHER PARTY UNLESS AUTHORIZED BY STONEL.</p> | | | | | | | | | | | | | | | | | | | | | |
| <p>Stonel METSO AUTOMATION, FERGIUS FALLS, MN U.S.A.</p> | | <p>TITLE I.S. CONTROL, AXIOM, AMI SERIES</p> | | | | | | | | | | | | | | | | | | | |
| <p>SCALE NS</p> <p>SIZE A</p> | | <p>SHEET 2 OF 2</p> <p>DATE 12/1/2005</p> | | | | | | | | | | | | | | | | | | | |
| <p>DRAWING NO. 105157</p> | | <p>REV. E</p> | | | | | | | | | | | | | | | | | | | |

StoneL Production Center

North America, 26271 US Hwy 59, Fergus Falls, MN 56537, USA. Tel. +1 218 739 5774. Fax +1 218 739 5776

www.StoneL.com

Metso Flow Control Inc.

South Korea, 235 Cheomdansaneop 1-ro, Daesowon-myeon, Chungju-si, Chungbuk-do, 380-871, Korea Tel. +82 43 852 7708, Fax +82 43 841 9890

Europe, Vanha Porvoontie 229, P.O. Box 304, FI-01301 Vantaa, Finland. Tel. +358 20 483 150. Fax +358 20 483 151

North America, 44 Bowditch Drive, P.O. Box 8044, Shrewsbury, MA 01545, USA. Tel. +1 508 852 0200. Fax +1 508 852 8172

South America, Av. Independência, 2500-Iporanga, 18087-101, Sorocaba-São Paulo, Brazil. Tel. +55 15 2102 9700. Fax +55 15 2102 9748

Asia Pacific, Haw Par Centre #06-01, 180 Clemenceau Avenue, Singapore 239922. Tel. +65 6511 1011. Fax +65 6250 0830

China, 11/F, China Youth Plaza, No.19 North Rd of East 3rd Ring Rd, Chaoyang District, Beijing 100020, China. Tel. +86 10 6566 6600. Fax +86 10 6566 2583.

Middle East, Roundabout 8, Unit AB-07, P.O. Box 17175, Jebel Ali Freezone, Dubai, United Arab Emirates. Tel. +971 4 883 6974. Fax +971 4 883 6836

www.metso.com/valves