

SEPARATION TUBE INSTALLATION MANUAL



For authorized service personnel only.
(PART NO. 9371636139-03)

- This manual describes the "Installation Specifications for Separation Tube Kits". For the "outdoor unit", refer to the Installation Instruction Sheet supplied with the outdoor unit, and for the "indoor unit", refer to the Installation Instruction Sheet supplied with the indoor unit.
- Please read this Installation Instruction Sheet thoroughly prior to installation, and perform the installation work in accordance with the instructions.
- Before performing the installation work, thoroughly read the "Safety Precautions" in the Installation Instruction Sheet supplied with the outdoor unit, and work accordingly.
- After installing the unit, perform a test run to make sure the unit operates normally. Then, explain to the customer how to operate and maintain the unit in accordance with the Operating Manual (supplied with the indoor unit).
- Hand this Installation Instruction Sheet, together with the Operating Manual, to the customer. Request the customer to keep them on hand.



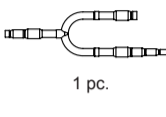
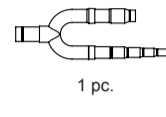
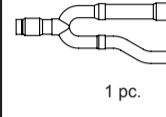

1

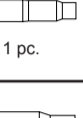
PARTS LIST

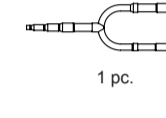
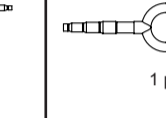

KIT NAME : UTP-BX567A

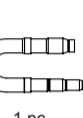
Description					
Liquid pipe	Discharge gas pipe	Suction gas pipe	Reducer	Insulation	Tape
			1 pc.		
1 pc.	1 pc.	1 pc.	1 pc.	Large 1 pc. Medium: 1 pc. Small 1 pc.	8 pcs.

KIT NAME : UTP-BX180A

Description					
Liquid pipe	Discharge gas pipe	Suction gas pipe	Reducer	Insulation	Tape
			1 pc.		
1 pc.	1 pc.	1 pc.	1 pc.	Large 1 pc. Medium: 1 pc. Small 1 pc.	8 pcs.

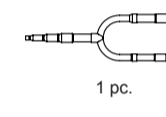
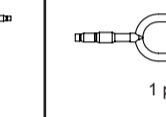
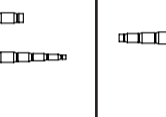
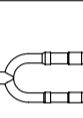
KIT NAME : UTP-BX090A

Description					
Liquid pipe	Discharge gas pipe	Suction gas pipe	Reducer	Insulation	Tape
			1 pc.		
1 pc.	1 pc.	1 pc.	1 pc.	Large 1 pc. Medium: 1 pc. Small 1 pc.	8 pcs.

2

SELECTION PROCEDURE

For details on the selection of the separation tube kits, refer to the Installation Manual supplied with the outdoor unit or the DESIGN & TECHNICAL DATA.

2. Select the connections with the pipe diameters that match the selected pipe sizes from the separation tubes, and cut them with a pipe cutter.

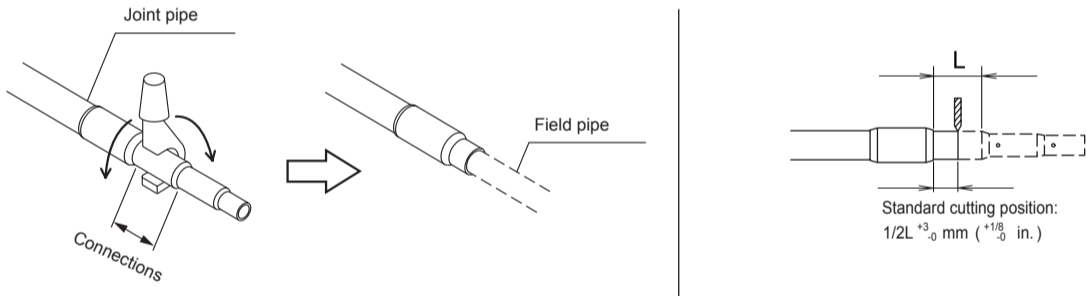

NOTE: Insert the field pipe firmly until it touches the joint pipe (Branch kit).

CAUTION

Use a pipe cutter to cut a pipe. Point the pipe downward while deburring so that cutting chips will not enter inside the pipe.

3. Place the separation tubes horizontally or vertically so that the refrigerant separates evenly.

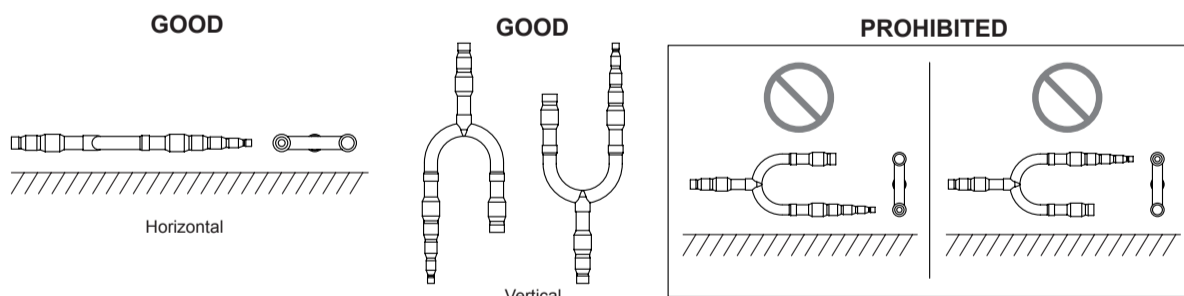

CAUTION

If it is placed horizontally, keep it within $\pm 15^\circ$. Otherwise, it will not separate the refrigerant evenly, causing a reduction in performance.

- During piping work, apply nitrogen gas while brazing the pipes. If pipes are brazed without applying nitrogen gas, it will create a large amount of oxidation film, which will cause a critical malfunction.
- To prevent moisture or foreign matter from entering during work, do not leave the piping open.
- Refer to the Installation Manual supplied with the outdoor unit for airtightness test and evacuation procedures.

PROHIBITED

GOOD: $\pm 15^\circ$

PROHIBITED

CAUTION

About the connecting curvature of field pipe and branch kit:

The field pipe should be connected to the branch kit so that the curved angle on each side is 3 degree or less.

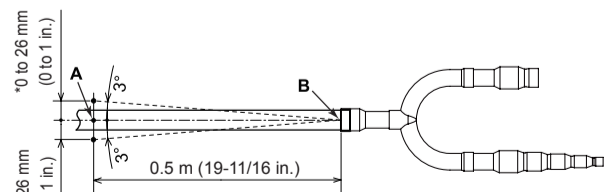

*: Allowed value based on "A" (center of field pipe) at 0.5 m (19-11/16 in.) from "B" (junction of the branch kit).

3

INSTALLATION PROCEDURE

1. The following table shows the sizes of the inlet and outlet pipes of the separation tubes.

KIT NAME : UTP-BX567A

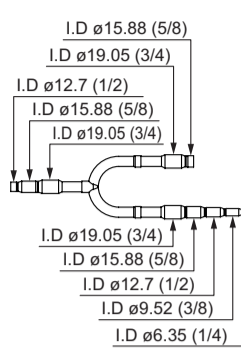
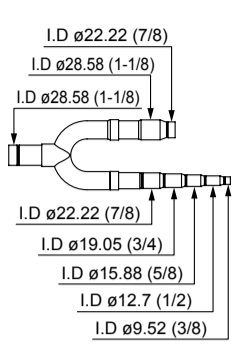
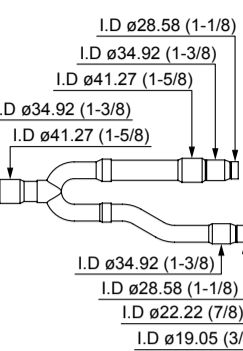
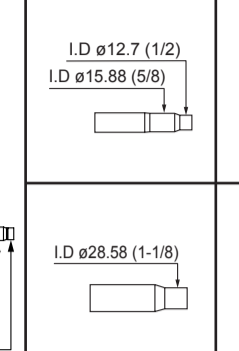
Description				Unit: mm (in.)
Liquid pipe	Discharge gas pipe	Suction gas pipe	Reducer	
				
I.D. $\phi 15.88$ (5/8) I.D. $\phi 19.05$ (3/4) I.D. $\phi 12.7$ (1/2) I.D. $\phi 15.88$ (5/8) I.D. $\phi 19.05$ (3/4) I.D. $\phi 19.05$ (3/4) I.D. $\phi 15.88$ (5/8) I.D. $\phi 12.7$ (1/2) I.D. $\phi 9.52$ (3/8) I.D. $\phi 6.35$ (1/4)	I.D. $\phi 22.22$ (7/8) I.D. $\phi 28.58$ (1-1/8) I.D. $\phi 28.58$ (1-1/8) I.D. $\phi 22.22$ (7/8) I.D. $\phi 19.05$ (3/4) I.D. $\phi 15.88$ (5/8) I.D. $\phi 12.7$ (1/2) I.D. $\phi 9.52$ (3/8)	I.D. $\phi 28.58$ (1-1/8) I.D. $\phi 34.92$ (1-3/8) I.D. $\phi 41.27$ (1-5/8) I.D. $\phi 34.92$ (1-3/8) I.D. $\phi 41.27$ (1-5/8) I.D. $\phi 34.92$ (1-3/8) I.D. $\phi 28.58$ (1-1/8) I.D. $\phi 22.22$ (7/8) I.D. $\phi 19.05$ (3/4)	I.D. $\phi 12.7$ (1/2) I.D. $\phi 15.88$ (5/8) I.D. $\phi 34.92$ (1-3/8) I.D. $\phi 28.58$ (1-1/8)	I.D. $\phi 34.92$ (1-3/8) I.D. $\phi 28.58$ (1-1/8)

KIT NAME : UTP-BX180A

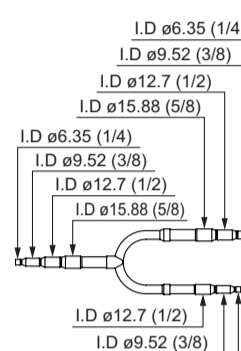
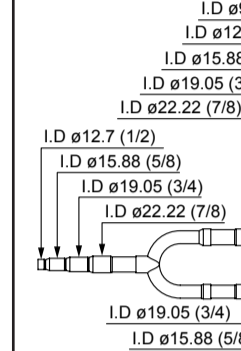
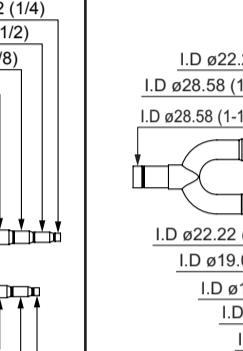
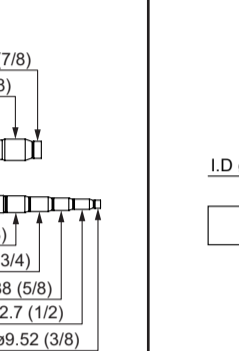
Description				Unit: mm (in.)
Liquid pipe	Discharge gas pipe	Suction gas pipe	Reducer	
				
I.D. $\phi 6.35$ (1/4) I.D. $\phi 9.52$ (3/8) I.D. $\phi 12.7$ (1/2) I.D. $\phi 15.88$ (5/8) I.D. $\phi 6.35$ (1/4) I.D. $\phi 9.52$ (3/8) I.D. $\phi 12.7$ (1/2) I.D. $\phi 15.88$ (5/8)	I.D. $\phi 9.52$ (3/8) I.D. $\phi 12.7$ (1/2) I.D. $\phi 15.88$ (5/8) I.D. $\phi 19.05$ (3/4) I.D. $\phi 22.22$ (7/8) I.D. $\phi 12.7$ (1/2) I.D. $\phi 15.88$ (5/8) I.D. $\phi 19.05$ (3/4) I.D. $\phi 22.22$ (7/8) I.D. $\phi 19.05$ (3/4) I.D. $\phi 15.88$ (5/8) I.D. $\phi 12.7$ (1/2) I.D. $\phi 9.52$ (3/8)	I.D. $\phi 22.22$ (7/8) I.D. $\phi 28.58$ (1-1/8) I.D. $\phi 22.22$ (7/8) I.D. $\phi 19.05$ (3/4) I.D. $\phi 15.88$ (5/8) I.D. $\phi 12.7$ (1/2) I.D. $\phi 9.52$ (3/8)	I.D. $\phi 22.22$ (7/8)	

KIT NAME : UTP-BX090A

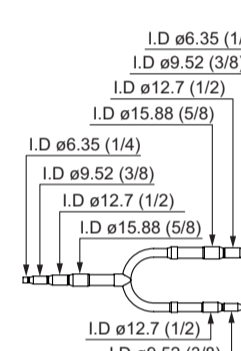
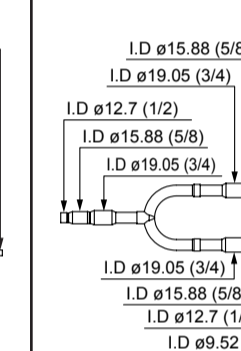
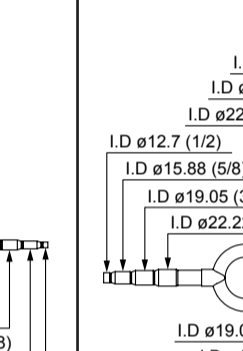
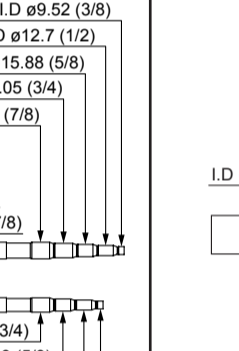
Description				Unit: mm (in.)
Liquid pipe	Discharge gas pipe	Suction gas pipe	Reducer	
				
I.D. $\phi 6.35$ (1/4) I.D. $\phi 9.52$ (3/8) I.D. $\phi 12.7$ (1/2) I.D. $\phi 15.88$ (5/8) I.D. $\phi 6.35$ (1/4) I.D. $\phi 9.52$ (3/8) I.D. $\phi 12.7$ (1/2) I.D. $\phi 15.88$ (5/8)	I.D. $\phi 15.88$ (5/8) I.D. $\phi 19.05$ (3/4) I.D. $\phi 12.7$ (1/2) I.D. $\phi 15.88$ (5/8) I.D. $\phi 19.05$ (3/4) I.D. $\phi 19.05$ (3/4) I.D. $\phi 15.88$ (5/8) I.D. $\phi 12.7$ (1/2) I.D. $\phi 9.52$ (3/8) I.D. $\phi 6.35$ (1/4)	I.D. $\phi 9.52$ (3/8) I.D. $\phi 12.7$ (1/2) I.D. $\phi 15.88$ (5/8) I.D. $\phi 19.05$ (3/4) I.D. $\phi 22.22$ (7/8) I.D. $\phi 12.7$ (1/2) I.D. $\phi 15.88$ (5/8) I.D. $\phi 19.05$ (3/4) I.D. $\phi 22.22$ (7/8) I.D. $\phi 19.05$ (3/4) I.D. $\phi 15.88$ (5/8) I.D. $\phi 12.7$ (1/2) I.D. $\phi 9.52$ (3/8)	I.D. $\phi 12.7$ (1/2)	

CAUTION

If the field pipe is connected with angle larger than specified, the balance of split refrigerant flow will be lost, and the refrigerant may concentrate upon specific outdoor unit as shown in the following figure. Such unbalanced refrigerant flow may cause a compressor malfunction.

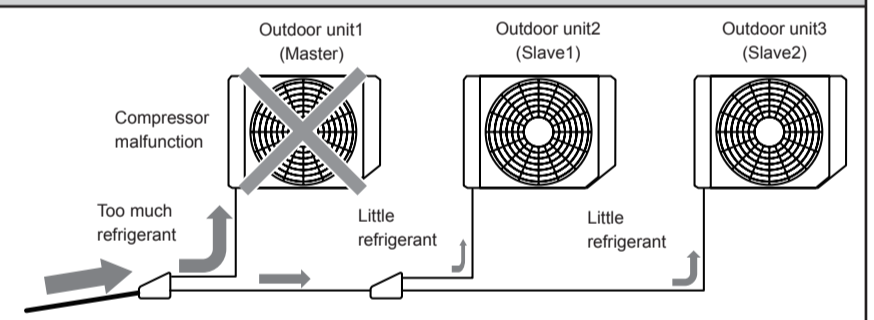

4. After brazing the pipes, use the supplied insulation to insulate them.

- 1) Remove the protective sheet from the double-stick tape that is affixed to the heat insulation.

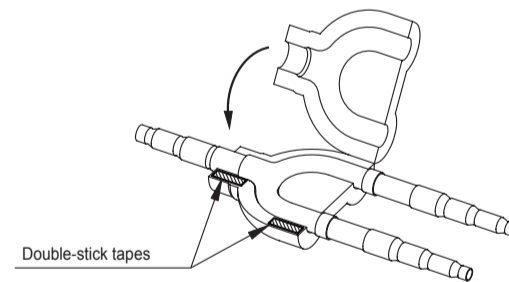

- 2) Be sure to install the tape (accessory) in each heat insulation to the 2 positions as shown in the following figure.

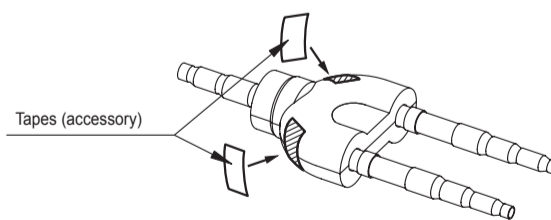

- 3) Use tape (Field supply) to seal the seam so that there will be no gap at the junction between the aforementioned heat insulation and the heat insulation on the local piping.

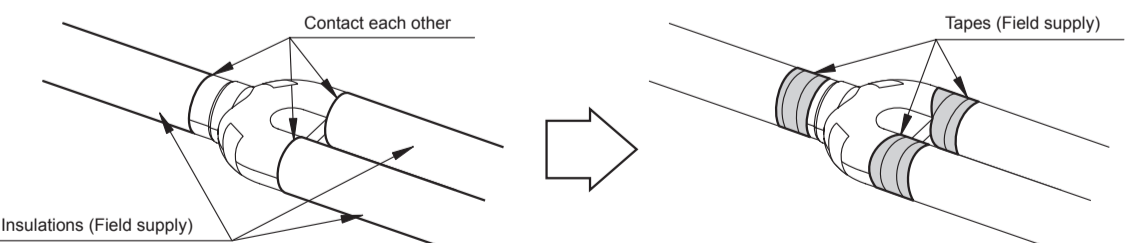

CAUTION

- Insulate the liquid and gas pipe completely. If not, it may cause the water condensation or performance reduction.
- Wrap the heat insulation with tape or pipe cover in order to extend the life time of heat insulation.
- Take proper measurement to strengthen by using another heat insulation at the following installing environment.
 - Environment temperature $\geq 35^\circ\text{C}$ (95°F) and humidity 85%.
 - Environment temperature $\geq 25^\circ\text{C}$ (77°F) and humidity 90%.

