

SUBMITTAL DATA: MSZ-GE06NA-9

6,000 BTU/H WALL-MOUNTED INDOOR UNIT FOR MXZ MULTI-ZONE HEAT-PUMP SYSTEMS

Job Name:

System Reference:

Date:



Indoor Unit: MSZ-GE06NA-9



Wireless Remote Controller

SPECIFICATIONS

Cooling Capacity* 6,000 Btu/h
Heating Capacity* 7,200 Btu/h

* Rating Conditions per AHRI Standard

Cooling | Indoor: 80° F (27° C) DB / 67° F (19° C) WB
Cooling | Outdoor: 95° F (35° C) DB / 75° F (24° C) WB
Heating at 47° F | Indoor: 70° F (21° C) DB / 60° F (16° C) WB
Heating at 47° F | Outdoor: 47° F (8° C) DB / 43° F (6° C) WB

(For data on specific indoor units [all ducted, all non-ducted, and both ducted and non-ducted] combinations, see the MXZ Technical and Service Manual.)

Electrical Requirements

Power Supply 208 / 230V, 1-Phase, 60 Hz
MCA 1 A

Voltage

Indoor - Outdoor S1-S2 AC 208 / 230V
Indoor - Outdoor S2-S3 DC ±24V
Indoor - Remote Controller MHK1 DC 3V
PAR-31MAA DC 12V
PAC-YT53CRAU DC 12V

Blower Motor (ECM) 0.76 F.L.A.

Airflow (Quiet - Lo - Med - Hi - Super Hi)

Cooling 145 - 170 - 237 - 321 - 399 Dry CFM
109 - 134 - 201 - 286 - 364 Wet CFM
Heating 145 - 170 - 233 - 321 - 406 CFM

Sound Pressure Level (Quiet - Lo - Med - Hi - Super Hi)

Cooling 19 - 22 - 30 - 37 - 43 dB(A)
Heating 19 - 22 - 30 - 37 - 43 dB(A)

| DIMENSIONS | UNIT INCHES / MM |
|------------|------------------|
| W | 31-7/16 / 799 |
| D | 9-1/8 / 232 |
| H | 11-5/8 / 295 |

Weight 22 lbs. / 10 kg
External Finish Munsell No. 1.0Y 9.2 / 0.2
Field Drainpipe Size O.D. 5/8" / 15.88 mm

Refrigerant Type R410A
Refrigerant Pipe Size O.D.
Gas Side 3/8" / 9.52 mm
Liquid Side 1/4" / 6.35 mm
Connection Method Flared

GENERAL FEATURES

- Wall-mounted indoor unit
- Standard Hybrid Catechin Prefilter is included with indoor unit
- Quiet operation
- Auto fan speed control: Quiet, Low, Medium, High, and Super High
- Hand-held Wireless Remote Controller
- Indoor unit powered from outdoor unit using A-Control
- Auto restart following a power outage
- Anti-allergy Enzyme Filter
- Limited warranty: five years parts and seven years compressor

ACCESSORIES

Indoor Unit

- Condensate Pump (230V; SI3100-230)

Controller Options

- Wireless Wall-mounted Remote Controller Kit (MHK1)*
 - Portable Central Controller (MCCH1)*
 - Outdoor Air Sensor (MOS1)*
 - Wired Wall-mounted Controller (PAR-31MAA requires MAC-333IF)*
 - Simple MA Remote Controller (PAC-YT53CRAU requires MAC-333IF)*
- *See Submittal for information on each option.
- System Control Interface (MAC-333IF)
 - Remote Temperature Sensor (M21-JKO-307)
 - Lockdown Bracket for Hand-held Controller (RCMKP1CB)



DIMENSIONS: MSZ-GE06NA-9

Unit: inch

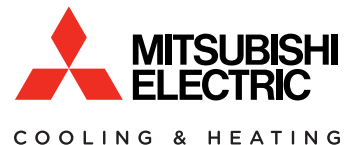
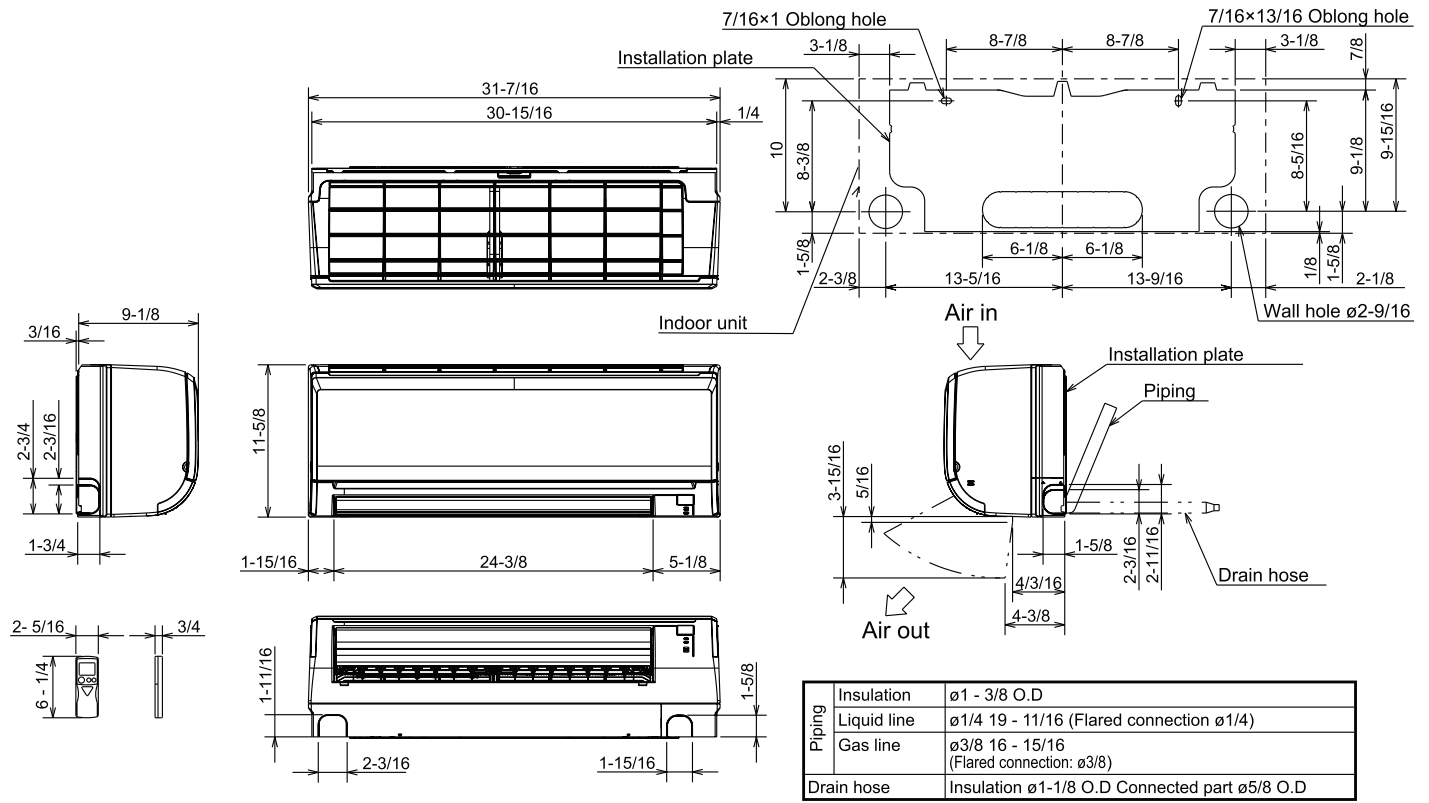

1340 Satellite Boulevard
Suwanee, GA 30024
Toll Free: 800-433-4822
www.mehvac.com