

5000-3 Series Lead Free ($\leq .25\%$ Pb) Mixing Valve

SUPERSEDES: AUGUST 1, 2013

EFFECTIVE: OCTOBER 24, 2016

Plant I.D. 001-4170

- ⚠ WARNING: Water temperatures above 120°F can cause serious injury. Mixing valve temperature setting should be done by a licensed professional per local code requirements. Use an accurate water thermometer to verify the final water temperature. The thermostatic strip provided must not be used for final water temperature verification.**
- ⚠ WARNING: The 5000 Series must not be installed on steam systems (water systems only).**
- ⚠ WARNING: 5000 Series mixing valves are certified to ASSE 1017 and not designed to compensate for system pressure fluctuations beyond the valves variation rating and should not be used where more sophisticated pressure compensating temperature controls are required.**

GENERAL:

The Taco 5000-3 Series is listed for ASSE 1017 applications.

- **NOTE: Non-union NPT valve does not have check valves.**
- All installations should be carried out by a Licensed Professional. Failure to comply with all aspects of these instructions may result in unsafe performance. All installations must comply with relevant State and Local codes or authorities.
- Ensure compatibility of valve installation, e.g. temperature of hot water, inlet pressure, flow rates, etc. - refer to product specifications. If the site conditions are outside of the specifications for the valve, the site conditions must be corrected or a valve that meets the conditions must be selected.
- Install in accordance with markings on valve body, i.e. hot water inlet - marked "H", cold water inlet - marked "C" and mixed outlet - marked with directional arrow.
- Valve may be installed in any position.
- Any inconsistency between these instructions and any specific instructions, bylaws or codes issued by local authorities must be referred back to Taco, Inc. prior to any installation taking place.
- During startup ensure that the valve is set to the desired temperature (valve preset at 105-115°F (41-46°C) with 150°F (66°C) hot water inlet temperature). If the valve temperature needs to be adjusted please refer to the instructions below (**SETTING VALVE OUTLET TEMPERATURE**).

NOTE: If the water supply is of poor quality a filter or strainer should be fitted at the system inlet so that both the water heater and the mixing valve are protected from dirt and debris.

FITTING VALVE TO PIPING SYSTEM:

- Flush all piping thoroughly before installing the valve (using water only). Not flushing the system properly is the most common cause of improper valve performance.
- Union valves come complete with union type connections for ease of installation and service. Non-union versions have NPT threads built into the body.
- Valve must be removed from the piping prior to soldering the end connections. It is recommended to use a spacer piece while soldering.
- For models using the temperature gauge and adaptor on the mixed outlet, attach the adaptor to the mixing valve body, insert the temperature gauge into the adaptor well and then attach the valve union connection to the adaptor.

SETTING VALVE OUTLET TEMPERATURE:

The Taco Series 5000-3 Mixing Valve is supplied factory set at 105-115°F with 150°F hot water inlet temperature. It may need to be altered depending on operating requirements.

1. Remove the green knob by inserting a small screwdriver in the notch and gently prying up. (See Figure 1)
2. Turn both the hot and cold water supplies on. Open an outlet, preferably a sink or basin rather than a shower. To calibrate, let the water run for 2 minutes and measure the outlet temperature with an accurate thermometer. Use the inset on the top of the cover provided to fit over the adjustment screw, adjust the knob counterclockwise to increase temperature and clockwise to decrease temperature. (See Figure 2)
3. Once the desired outlet temperature has been achieved refit the knob so that it snaps onto the body. This helps to prevent tempering with the set temperature.
4. A temperature strip is provided with each mixing valve and can be used as a reference to set the temperature, however a more accurate device should be used to ensure a correct temperature setting.

Taco	
F	C
160	71
155	68
150	65
145	63
140	60
135	57
130	54
125	52
120	49
115	46
110	43
105	40
100	38
95	35
90	32
85	29

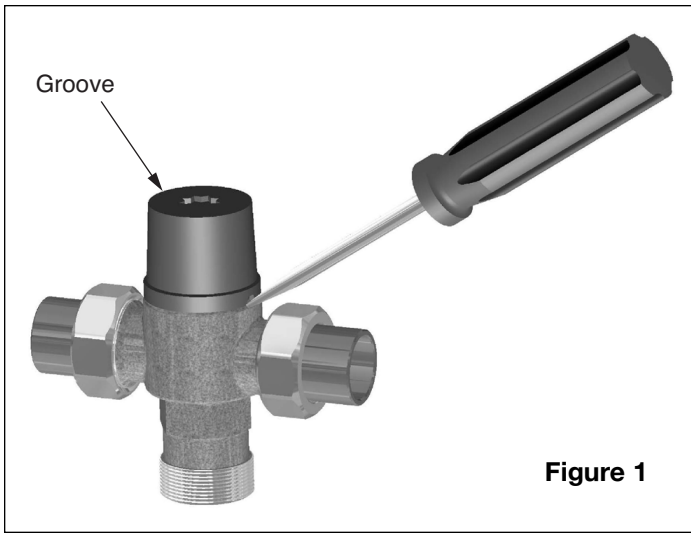

Figure 1

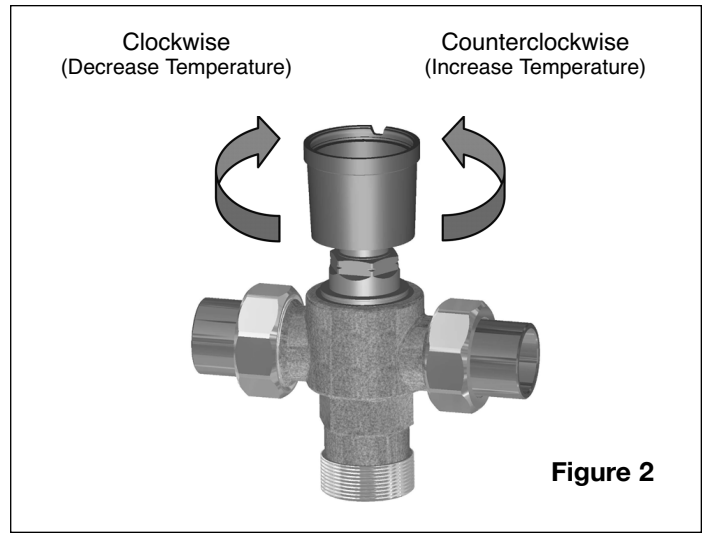
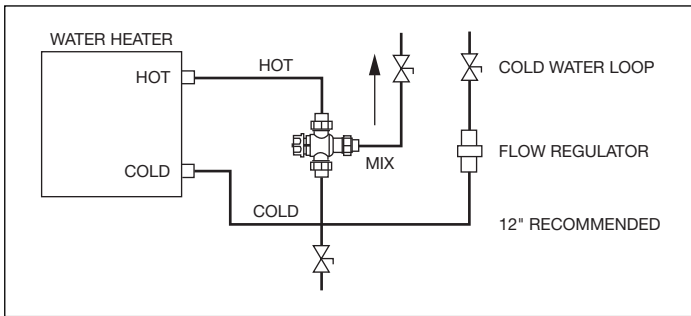
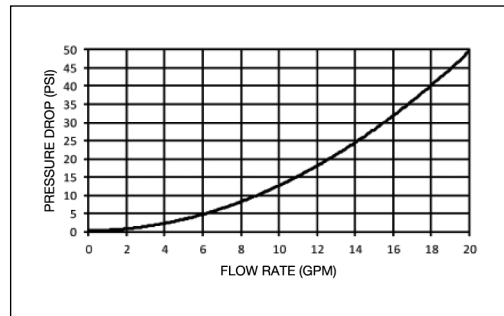

Figure 2

TYPICAL ASSE 1017 INSTALLATION:



FLOW CURVE:



TROUBLESHOOTING:

This troubleshooting table is intended as a helpful guide and is not all inclusive. There could be other causes and solutions for a non-functioning product.

FAULT / SYMPTOM	CAUSE	POSSIBLE SOLUTION
1. The desired mixed water temperature cannot be obtained or valve is difficult to set.	<ul style="list-style-type: none"> Inlet temperatures are not within specification limits. Hot and cold supplies are reversed. Strainers are blocked. 	<ul style="list-style-type: none"> Ensure inlet temperatures are within the specified limits for the valve. Refit the valve with Hot/Cold supplies fitted to the correct connections. Clean strainers.
2. Mix temperature unstable or changing over time.	<ul style="list-style-type: none"> Strainers are blocked. Fluctuating supply pressures. 	<ul style="list-style-type: none"> Clean strainers. Install pressure regulating valves on both hot and cold supplies.
3. Either full hot or full cold water flowing from outlet fixture.	<ul style="list-style-type: none"> Valve is incorrectly set. Hot and cold supplies are reversed. Hot/Cold water has migrated to other inlet. Refer also to point 1. 	<ul style="list-style-type: none"> Adjust mix temperature as required. Refit the valve with Hot/Cold supplies fitted to the correct connections. Verify the check valve is not fouled. Clean if necessary.
4. No flow from the valve outlet.	<ul style="list-style-type: none"> Hot or cold water supply failure. Strainers are blocked. 	<ul style="list-style-type: none"> Restore inlet supplies and check mix temperature. Clean strainers.
5. Flow rate reduced or fluctuating.	<ul style="list-style-type: none"> Strainers are blocked. Fluctuating supply pressures. 	<ul style="list-style-type: none"> Clean strainers. Install pressure regulating valves.
6. Mixed water temperature does not change when temperature adjuster is altered.	<ul style="list-style-type: none"> Hot and cold supplies are reversed. 	<ul style="list-style-type: none"> Refit the valve with Hot/Cold supplies fitted to the correct connections.
7. Hot water flows into the cold water system or vice versa.	<ul style="list-style-type: none"> Check valves fouled. 	<ul style="list-style-type: none"> Clean check valves, ensuring debris is removed.
8. Valve is noisy.	<ul style="list-style-type: none"> Excessive water velocity. Valve sized incorrectly. 	<ul style="list-style-type: none"> Reduce water velocity (best achieved by fitting a pressure regulating valve). Check valve specifications and ensure the appropriate valve is used for required flow.

SPECIFICATIONS:

Hot Water Inlet Temperature:	120-180°F (60-82°C)	Factory Preset:	115-120°F (41-46°C)
Cold Water Inlet Temperature:	39-80°F (4-27°C)	Outlet Water Temperature Range:	85-176°F (29-80°C)
Maximum Design Pressure:	230 psi (13.8 Bar)	Minimum Temperature Differential (between hot supply and outlet):	10°F (5.6°C)
Minimum Flow Rate:	1 GPM (3.8 L/min)	Allowable Supply Pressure Variation:	±20% ¹
Maximum Flow Rate:	20 GPM (76 L/min)	Accuracy of Outlet Temperature:	±3°F (±2°C) ²

Notes:

1. Maximum allowable variation in either supply pressure in order to control the outlet temperature to within ±3°F.
Warning: Pressure variations outside of this range may cause changes in the outlet temperature.
2. Per ASSE 1017 testing process.

MAINTENANCE:

The Taco Series 5000-3 Mixing Valve is an ASSE 1017 SAFETY VALVE. It does not require routine maintenance but should be checked annually to be sure it is functioning properly. For installations with poor water quality it may be necessary to inspect the mixing valve more frequently. Replacement element assemblies are available.

O-RING/PISTON SUB-ASSEMBLY REPLACEMENT:

1. Isolate the valve from the water supply.
2. Unscrew the union nuts and remove the valve body from the system. For non-union valves remove the valve body from the piping system. **Removing the valve from the piping system is not required but may make replacement easier.**
3. Using a screwdriver, pry the green cap from the valve.
4. Secure the valve body (using the flats on the body) and unscrew the brass cap to remove the internals of the valve.
5. Remove the piston assembly out of the top of the valve. If necessary, push the piston assembly from the outlet port of the valve.
6. Using a clean cloth gently wipe out the valve body paying particular attention to the o-ring half way down the inside of the valve body.
7. Remove the o-ring from the cap. Lightly grease the new cap o-ring and re-grease the o-ring half way down the inside of the valve with the grease packet provided.
8. Assemble in the reverse order.
9. When re-fitting the brass cap do not over tighten, as this is an o-ring seal.
10. If removed, reinstall the valve into the piping system and set the outlet mix temperature as indicated above in **SETTING THE OUTLET TEMPERATURE.**

LIMITED WARRANTY STATEMENT

Taco, Inc. will repair or replace without charge (at the company's option) any product or part which is proven defective under normal use within one (1) year from the date of start-up or one (1) year and six (6) months from date of shipment (whichever occurs first).

In order to obtain service under this warranty, it is the responsibility of the purchaser to promptly notify the local Taco stocking distributor or Taco in writing and promptly deliver the subject product or part, delivery prepaid, to the stocking distributor. For assistance on warranty returns, the purchaser may either contact the local Taco stocking distributor or Taco. If the subject product or part contains no defect as covered in this warranty, the purchaser will be billed for parts and labor charges in effect at time of factory examination and repair.

Any Taco product or part not installed or operated in conformity with Taco instructions or which has been subject to misuse, misapplication, the addition of petroleum-based fluids or certain

chemical additives to the systems, or other abuse, will not be covered by this warranty.

If in doubt as to whether a particular substance is suitable for use with a Taco product or part, or for any application restrictions, consult the applicable Taco instruction sheets or contact Taco at (401-942-8000).

Taco reserves the right to provide replacement products and parts which are substantially similar in design and functionally equivalent to the defective product or part. Taco reserves the right to make changes in details of design, construction, or arrangement of materials of its products without notification.

TACO OFFERS THIS WARRANTY IN LIEU OF ALL OTHER EXPRESS WARRANTIES. ANY WARRANTY IMPLIED BY LAW INCLUDING WARRANTIES OF MERCHANTABILITY OR FITNESS IS IN EFFECT ONLY FOR THE DURATION OF THE EXPRESS WARRANTY SET

FORTH IN THE FIRST PARAGRAPH ABOVE.

THE ABOVE WARRANTIES ARE IN LIEU OF ALL OTHER WARRANTIES, EXPRESS OR STATUTORY, OR ANY OTHER WARRANTY OBLIGATION ON THE PART OF TACO.

TACO WILL NOT BE LIABLE FOR ANY SPECIAL, INCIDENTAL, INDIRECT OR CONSEQUENTIAL DAMAGES RESULTING FROM THE USE OF ITS PRODUCTS OR ANY INCIDENTAL COSTS OF REMOVING OR REPLACING DEFECTIVE PRODUCTS.

This warranty gives the purchaser specific rights, and the purchaser may have other rights which vary from state to state. Some states do not allow limitations on how long an implied warranty lasts or on the exclusion of incidental or consequential damages, so these limitations or exclusions may not apply to you.



A Taco Family Company

Taco, Inc., 1160 Cranston Street, Cranston, RI 02920 | Tel: (401) 942-8000 | FAX: (401) 942-2360

Taco (Canada), Ltd., 8450 Lawson Road, Suite #3, Milton, Ontario L9T 0J8 | Tel: (905) 564-9422 | FAX: (905) 564-9436

Visit our web site: www.TacoComfort.com | Printed in USA | ©2016 Taco, Inc.

