



LF PEX TEE WATER HAMMER ARRESTOR

Product Features

- Helps to eliminate shock waves generated in piping systems by sudden on/off changes in flow
- Polypropylene piston
- AA arrestors are suitable for 1-3 fixture units
- May be installed at any angle
- To function more effectively, please install within 6 feet of the fixture the arrestor is servicing.
- Temperature range: 33°F to 180°F
- Max. working pressure: 350psi
- Meets ASSE 1010
- NSF 61 & NSF 372 compliant
- cUPC/IAPMO listed



PFXWHAPTD

Model Numbers:

- PFXWHAPTD 1/2" F1807 PEX
- PFXWHAPPTD 1/2" F1960 PEX

Product Specifications

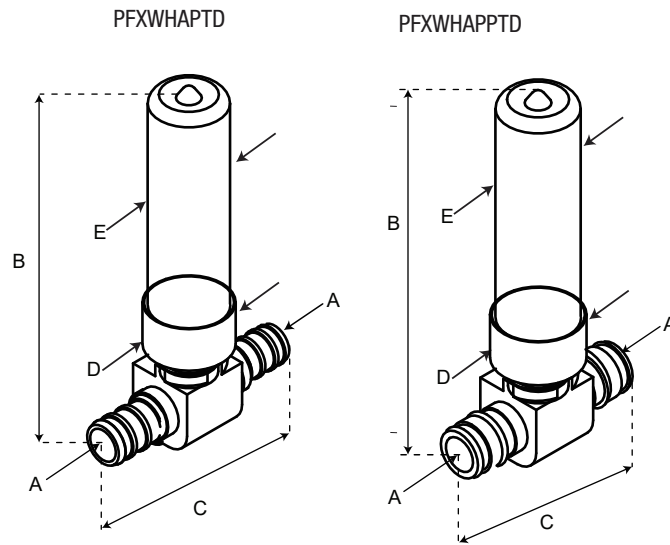

Model Numbers	A	B	C	D	E
PFXWHAPTD	1/2" F1807 PEX	3-7/8" (98.4mm)	2-3/16" (55.6mm)	15/16"(25.01mm)	7/8"(22.2mm)
PFXWHAPPTD	1/2" F1960 PEX	3-7/8" (98.4mm)	2-1/4" (57.2mm)	15/16"(25.01mm)	7/8"(22.2mm)

* All measurements are nominal. Please verify before actual installation.

Warranty and Codes

This PROFLO product carries a 1-year limited warranty.

