

CADDY[®]

Fire Sprinkler Hanging & Bracing Products



Innovative Hanging & Bracing Fire Protection Solutions



ERICO[®]

Innovative Products From a Trusted Leader

To help ensure the availability and operation of safety systems after an earthquake event, many building and industry codes now include requirements for the design and installation of seismic sway bracing for non-structural components, such as fire sprinkler, mechanical, electrical and plumbing systems. The innovative line of CADDY® Bracing Systems was developed to help keep fire sprinkler systems intact after a seismic event and to minimize water damage resulting from leaks or ruptures.

CADDY Bracing Systems provide contractors with high-quality, engineered solutions, which include rigid bracing, cable bracing and rod stiffeners.

Features:

- Quick and easy installation
- Lower total installed cost
- OSHPD® Pre-Approved
- Meets NFPA® 13
- cULus® Listed
- FM® Approved



CADDY® Bracing System Software

CADDY® Bracing Systems software for fire protection simplifies the selection and engineering calculations associated with CADDY bracing products. The software supports various editions of NFPA® 13, as well as various editions of the IBC® and other building codes. It also generates submittal documents for engineering companies or the Authorities Having Jurisdiction (AHJ).

Features:

- Web-based version incorporates customer feedback from the highly successful CADDY® Bracing Systems Calculator
- Users can create and save brace designs for multiple projects
- Create, edit and copy brace designs for multiple zones of influence
- Choose rigid or cable bracing depending on code and listing conditions
- Use for sway brace design and branch line restraint design
- Includes ability to design bracing to FM® Loss Prevention Datasheet 2-8 for Earthquake Protection for Water-Based Fire Protection Systems
- Checks for net vertical seismic load when required
- Provides a real-time visual image and drawing for the specific brace configuration
- Generates NFPA 13 and FM DS 2-8 calculation sheets
- Produces project or brace bill of materials

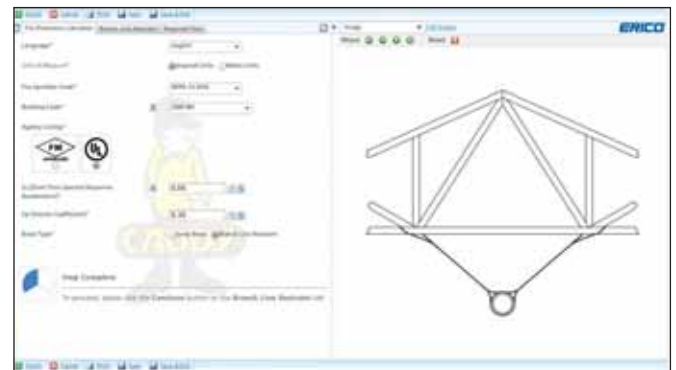

Pipe Hangers



115 Standard Duty
Loop Hanger
Page 15



Surge Restraint
Page 16



Yook Hanger
Page 16



105 Stainless Steel
Loop Hanger
Page 17



401 Galvanized
Clevis Hanger
Page 18-19



410 Light Duty
Clevis Hanger
Page 20



512 CADDY® EZ RISER
for Close Quarters
Page 21



510 CADDY® EZ RISER
Page 22-23



455 Malleable
Split Ring Hanger
Page 24



456 Malleable Split Ring
Hanger for Copper Tube
Page 25



CPVC Hanging System



107 Wraparound Strap
for CPVC Pipe
Page 27



108 2-Hole Strap
for CPVC Pipe
Page 28



109 Side Mount Strap
for CPVC Pipe
Page 29



SOSR Stand Off 2-Hole Strap
for CPVC Pipe
Page 30



CADDY® MACROFIX PLUS NI
with Easy Closure
Page 31



3TW Fastener for
SOSR Series
Page 32

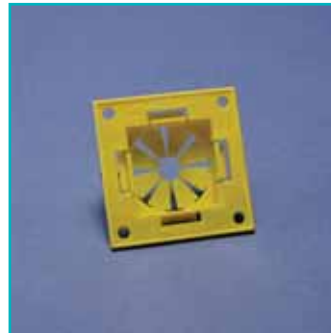

Easy Snap Grommet for
Factory Punched Holes
Page 32



Snap-On Nail Plate
Page 33

Pipe Supports



721 Pipe Support
with U-Bolt
Page 35



722 Adjustable
Pipe Support
Page 36



723 Adjustable
Pipe Support Assembly
Page 36



724 Adjustable Pipe Support
Assembly with U-Bolt
Page 37

CADDY® ROD LOCK



CADDY® ROD LOCK
Beam Clamp
Page 39



CADDY® ROD LOCK
Anchor Screw
Page 40



SN Series Nut
Page 41

Structural Attachments



300 Universal Beam Clamp
Page 44



310 Universal Beam Clamp,
Wide Mouth
Page 45



305 Stainless Steel
Top-Mount Beam Clamp
Page 46



300C Standard
Retainer Strap
Page 47



34SL Retrofit
Retainer Strap
Page 48



PH Multi-Purpose
Purlin Clamp
Page 49



PHSW Multi-Purpose
Purlin Clamp with Swivel
Page 50



315 Malleable Iron
Purlin Clamp
Page 51



Structural Attachments



547/548 C-Clamp
Page 51

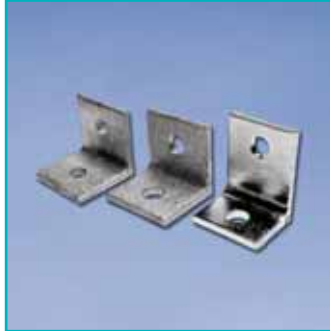

325 Steel
Side Beam Attachment
Page 52



327 Malleable Iron
Side Beam Attachment
Page 53



326 Universal Steel
Side Beam Attachment
Page 54



329 Side Beam Attachment
Page 55



328 Threaded Steel
Side Beam Attachment
Page 56



37 Steel Eye Socket
Rod Hanger
Page 57



38 Offset Steel
Eye Socket Rod Hanger
Page 58



365 Steel Wall or
Ceiling Plate
Page 59



365M Malleable Iron Wall
or Ceiling Plate
Page 60



352 Standard Duty
Welded Wall Bracket
Page 61



353 Heavy Duty
Welded Wall Bracket
Page 62



370A Single Concrete
Insert Plate and Rod
Page 63



355 Concrete Insert Plate
Page 64

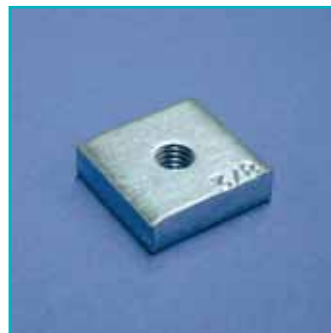

355N Nut for 355 Series
Page 65

Rigid Bracing System



Bar Joist Attachment
Page 68-69



Adjustable I-Beam Attachment
Page 70



I-Beam Attachment
Page 71



Multi Attachment
Page 72



Universal Structural Attachment
Page 73



Easy Universal Sway Brace
Page 74-75



Standard Universal Sway Brace
Page 76-77



Quick Grip Jr. Lateral Sway Brace
Page 78-79



Quick Grip Lateral Sway Brace
Page 80-81



Shear Bolt
Page 82



Shear Nut
Page 82



Cable Bracing System



Cable Spool
Page 86



Crimping Sleeve
Page 86



Stake Eye Kit
Page 87



Loop Attachment Clip
Page 88



No Pry Clip
Page 88



Universal Restraint Clip
Page 89



Universal Restraint Clip,
Retrofit
Page 90



Cable Cutter
Page 91

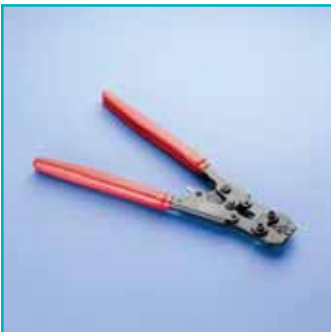

Manual Swaging Tool
Page 91



Multi-Size Manual
Swaging Tool
Page 92



Battery Powered
Swaging Tool
Page 92



Die Set for Battery Powered
Swaging Tool
Page 92

Branch Line Restraint System



Branch Line Restraint
Pipe Attachment
Page 94



Branch Line Restraint Structure
Attachment to Steel
Page 95



Branch Line Restraint Structure
Attachment to Wood/Concrete
Page 96



Branch Line Restraint Structure
Attachment to Threaded Hole
Page 97

Bracing Accessories



Strut Seismic Hinge
Page 99



Pipe Rod Stiffener
Page 100



Strut Rod Stiffener
Page 101



Hardware



Threaded Rod
Page 103



150M Standard U-Bolt
Page 104-105



EM-HEX Rod Coupler
Page 106



25R Hex Rod Reducer
Page 106



42 Hex Head Lag Screw
Page 107



43 Wood Drive Screw
Page 108



80 Tie Bolt
Page 109

Anchors



Drop-In Anchor
Page 112



Flanged Drop-in Anchor
Page 112



Spike Anchor
Page 113



Wedge Expansion
Anchor Bolt
Page 114



Concrete Anchor Screw
Page 115



Screw Drill Bits
Page 115



HangerMate® Vertical
Mount Screw for Steel
Page 116



HangerMate® Vertical Mount
Screw for Steel with Lock Nut
Page 116



HangerMate® Horizontal
Mount Screw for Steel
Page 117



HangerMate® Horizontal Mount
Screw for Steel with Lock Nut
Page 117



HangerMate® Vertical Mount
Screw for Wood
Page 118



HangerMate® Horizontal
Mount Screw for Wood
Page 118



Anchors



HangerMate® Vertical Mount
Screw for Concrete
Page 119



HangerMate® SDS Drill Bit
for Hammer Drills
Page 119



HangerMate® Drill Bit
Adaptor
Page 120



HangerMate® Tanged Drill Bit
for Hammer Drills
Page 120



HangerMate® Hex
Drive Socket
Page 121



HangerMate® Drive Sleeve
Page 121

Pipe Hangers



115 Standard Duty
Loop Hanger
Page 15



Surge Restraint
Page 16



Yook Hanger
Page 16



105 Stainless Steel
Loop Hanger
Page 17



401 Galvanized
Clevis Hanger
Page 18-19



410 Light Duty
Clevis Hanger
Page 20



512 CADDY® EZ RISER
for Close Quarters
Page 21



510 CADDY® EZ RISER
Page 22-23



455 Malleable
Split Ring Hanger
Page 24



456 Malleable Split Ring
Hanger for Copper Tube
Page 25



115 Standard Duty Loop Hanger

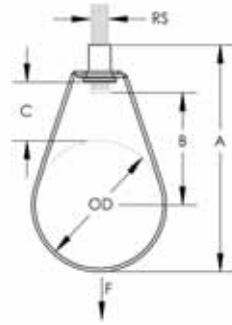

The 115 Standard Duty Loop Hanger, part of the CADDY® line of fasteners and supports from ERICO, is ideal for suspending stationary, non-insulated pipe lines, including CPVC pipes, in fire sprinkler systems. A knurled insert nut helps simplify vertical adjustments and flared edges on the base (1/2" to 2" sizes) help protect pipes from coming into contact with any sharp edges of the hanger.

Features

- Flared edges help prevent any sharp surfaces from coming into contact with the pipe (1/2" to 2" sizes)
- Retained insert nut helps ensure the loop hanger and insert nut stay together
- Recommended for the suspension of stationary non-insulated pipe lines
- Manufactured to use the minimum rod size permitted by NFPA® for fire sprinkler piping
- Conforms with Federal Specification WW-H-171 (Type 10), Manufacturers Standardization Society (MSS) SP-58 and SP-69 (Type 10)

Specifications

Material: Steel

Finish: Pre-galvanized



Part Number	Pipe Size	Outer Diameter OD	Rod Size RS	A	B	C	Static Load F
1150050EG	1/2"	0.840"	3/8"	2 13/16"	1 1/8"	1"	300 lb
1150075EG	3/4"	1.050"	3/8"	3"	1 3/16"	15/16"	300 lb
1150100EG	1"	1.315"	3/8"	3 1/4"	1 3/8"	15/16"	300 lb
1150125EG	1 1/4"	1.660"	3/8"	3 9/16"	1 1/2"	15/16"	300 lb
1150150EG	1 1/2"	1.900"	3/8"	3 13/16"	1 5/8"	15/16"	300 lb
1150200EG	2"	2 3/8"	3/8"	4 1/4"	1 7/8"	15/16"	300 lb
1150250EG	2 1/2"	2 7/8"	3/8"	5 9/16"	2 13/16"	1 9/16"	525 lb
1150300EG	3"	3 1/2"	3/8"	6 9/16"	3 1/2"	1 15/16"	525 lb
1150350EG	3 1/2"	4"	3/8"	7 1/16"	3 3/4"	1 15/16"	585 lb
1150400EG	4"	4 1/2"	3/8"	7 9/16"	4"	1 15/16"	650 lb
1150500EG	5"	5 9/16"	1/2"	9 13/16"	4 3/4"	2 1/4"	1,000 lb
1150600EG	6"	6 5/8"	1/2"	11 5/16"	6 5/16"	3 5/16"	1,000 lb
1150800EG	8"	8 5/8"	1/2"	12 7/8"	6 7/8"	2 7/8"	1,000 lb

Surge Restraint



Features

- Surge restraint for 115 standard duty loop hangers

Specifications

Material: Steel
Finish: CADDY® ARMOUR



Part Number	Pipe Size
SR6	1/2" – 2"

Yook Hangers

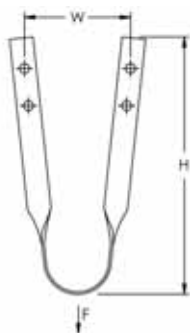

Features

- Use in place of U-hook
- Use with Model #43, size #16 x 2" L Wood Drive Screws

Specifications

Material: Steel
Finish: Pre-galvanized



Part Number	Pipe Size	Height H	Width W	Static Load F
1351206EG	1" – 1 1/4"	6 7/8"	2 13/16"	250 lb
1352006EG	1 1/2" – 2"	6 7/8"	3 1/2"	250 lb
1353008EG	2 1/2" – 3"	8 7/8"	4 13/16"	320 lb
1354008EG	3 1/2" – 4"	8 7/8"	5 15/16"	560 lb

For 2-1/2" thru 4" pipe sizes, use two drive screws per leg.



105 Stainless Steel Loop Hanger

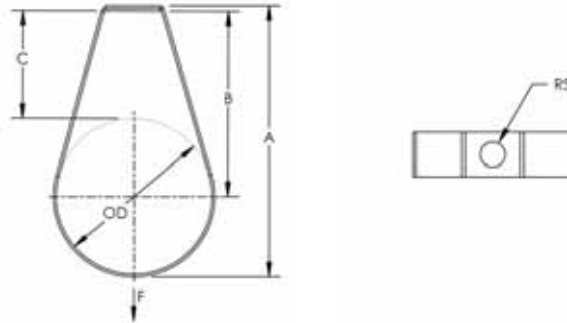

Features

- Recommended for the suspension of stationary stainless steel pipe lines
- Conforms with Federal Specification WW-H-171 (Type 10), Manufacturers Standardization Society (MSS) SP-58 and SP-69 (Type 10)

Specifications

Part Number	Pipe Size	Outer Diameter OD	Rod Size RS	A	B	C	Static Load F
Material: Stainless steel 304							
1050050S4	1/2"	0.675"	3/8"	2 7/8"	2 5/16"	1 7/8"	610 lb
1050075S4	3/4"	1.050"	3/8"	3 1/8"	2 3/8"	1 7/8"	610 lb
1050100S4	1"	1.315"	3/8"	3 3/8"	2 9/16"	1 7/8"	610 lb
1050125S4	1 1/4"	1.660"	3/8"	3 3/4"	2 11/16"	1 7/8"	610 lb
1050150S4	1 1/2"	1.900"	3/8"	4 1/16"	2 15/16"	2"	610 lb
1050200S4	2"	2 3/8"	3/8"	4 7/16"	3 1/16"	1 7/8"	610 lb
1050250S4	2 1/2"	2 7/8"	1/2"	4 15/16"	3 5/16"	1 7/8"	970 lb
1050300S4	3"	3 1/2"	1/2"	5 9/16"	3 5/8"	1 7/8"	970 lb
1050350S4	3 1/2"	4"	1/2"	6 1/16"	3 7/8"	1 7/8"	970 lb
1050400S4	4"	4 1/2"	5/8"	6 9/16"	4 1/8"	1 7/8"	1,250 lb
1050500S4	5"	5 9/16"	5/8"	7 5/8"	4 11/16"	1 7/8"	1,250 lb
1050600S4	6"	6 5/8"	3/4"	8 3/4"	5 1/16"	1 3/4"	1,600 lb
1050800S4	8"	8 5/8"	3/4"	10 3/4"	6 1/16"	1 3/4"	1,800 lb
Material: Stainless steel 316							
1050200S6	2"	2 3/8"	3/8"	4 7/16"	3 1/16"	1 7/8"	610 lb
1050300S6	3"	3 1/2"	1/2"	5 9/16"	3 5/8"	1 7/8"	970 lb
1050400S6	4"	4 1/2"	5/8"	6 9/16"	4 1/8"	1 7/8"	1,250 lb
1050600S6	6"	6 5/8"	3/4"	8 3/4"	5 1/16"	1 3/4"	1,600 lb

401 Galvanized Clevis Hanger



Features

- Recommended for the suspension of stationary non-insulated pipe lines
- Conforms with U.S. Federal Specification WW-H-171 (Type 1), Manufacturers Standardization Society (MSS) SP-58 and SP-69 (Type 1)

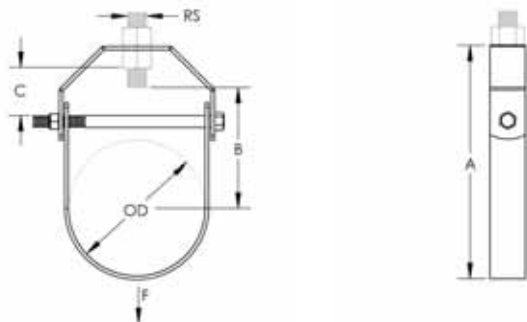

Specifications

Material: Steel



Part Number	Pipe Size	Outer Diameter OD	Rod Size RS	A	B	C	Static Load F	Listings Approvals
Finish: Electro-galvanized								
4010050EG	1/2"	0.840"	3/8"	2 1/8"	1 1/16"	1/4"	610 lb	cUL, UL
4010075EG	3/4"	1.050"	3/8"	2 3/8"	1 3/16"	3/8"	610 lb	cUL, UL
4010100EG	1"	1.315"	3/8"	2 13/16"	1 1/2"	9/16"	610 lb	cUL, UL
4010125EG	1 1/4"	1.660"	3/8"	3 5/16"	1 13/16"	11/16"	610 lb	cUL, UL
4010150EG	1 1/2"	1.900"	3/8"	4"	2 3/8"	1 1/16"	610 lb	cUL, UL
4010200EG	2"	2 3/8"	3/8"	4 1/2"	2 5/8"	1 1/8"	610 lb	cUL, UL
4010250EG	2 1/2"	2 7/8"	1/2"	5 1/4"	3"	1 1/16"	1,130 lb	cUL, UL, FM
4010300EG	3"	3 1/2"	1/2"	6"	3 7/16"	7/8"	1,130 lb	cUL, UL, FM
4010350EG	3 1/2"	4"	1/2"	6 1/2"	3 11/16"	1 3/8"	1,130 lb	cUL, UL, FM
4010400EG	4"	4 1/2"	5/8"	7 3/4"	4 5/8"	1 3/4"	1,130 lb	cUL, UL, FM



401 Galvanized Clevis Hanger

Part Number	Pipe Size	Outer Diameter OD	Rod Size RS	A	B	C	Static Load F	Listings Approvals
Finish: Electro-galvanized								
4010500EG	5"	5 9/16"	5/8"	9 3/4"	5 5/8"	2 3/16"	1,430 lb	cUL, UL, FM
4010600EG	6"	6 5/8"	3/4"	11 3/4"	7 1/16"	2 11/16"	1,940 lb	cUL, UL, FM
4010800EG	8"	8 5/8"	3/4"	14"	8"	3 1/8"	2,000 lb	cUL, UL, FM
4011000EG	10"	10 3/4"	7/8"	16 1/2"	9 1/16"	2 9/16"	3,600 lb	-
4011200EG	12"	12 3/4"	7/8"	18 5/8"	10 3/16"	3 1/16"	3,800 lb	-
4011400EG	14"	14"	1"	21 3/4"	12 1/8"	4 3/8"	4,200 lb	-
4011600EG	16"	16"	1"	24"	13 1/2"	4 5/8"	4,600 lb	-
4011800EG	18"	18"	1 1/8"	26 3/4"	15"	5 1/8"	4,800 lb	-
4012000EG	20"	20"	1 1/4"	30"	17"	6"	4,800 lb	-
4012400EG	24"	24"	1 1/4"	34 1/8"	18 5/8"	5 11/16"	4,800 lb	-
Finish: Hot-dip galvanized								
4010050HD	1/2"	0.840"	3/8"	2 1/8"	15/16"	1/4"	610 lb	cUL, UL
4010075HD	3/4"	1.050"	3/8"	2 3/8"	1 1/16"	3/8"	610 lb	cUL, UL
4010100HD	1"	1.315"	3/8"	2 13/16"	1 3/8"	9/16"	610 lb	cUL, UL
4010125HD	1 1/4"	1.660"	3/8"	3 5/16"	1 3/4"	11/16"	610 lb	cUL, UL
4010150HD	1 1/2"	1.900"	3/8"	4"	2 1/4"	1 1/16"	610 lb	cUL, UL
4010200HD	2"	2 3/8"	3/8"	4 1/2"	2 9/16"	1 1/8"	610 lb	cUL, UL
4010250HD	2 1/2"	2 7/8"	1/2"	5 1/4"	2 13/16"	1 1/16"	1,130 lb	cUL, UL, FM
4010300HD	3"	3 1/2"	1/2"	6"	3 1/4"	7/8"	1,130 lb	cUL, UL, FM
4010400HD	4"	4 1/2"	5/8"	7 3/4"	4 1/4"	1 3/4"	1,130 lb	cUL, UL, FM
4010500HD	5"	5 9/16"	5/8"	9 3/4"	5 11/16"	2 3/16"	1,430 lb	cUL, UL, FM
4010600HD	6"	6 5/8"	3/4"	11 3/4"	6 7/8"	2 11/16"	1,940 lb	cUL, UL, FM
4010800HD	8"	8 5/8"	3/4"	14"	8 1/8"	3 1/8"	2,000 lb	cUL, UL, FM
4011000HD	10"	10 3/4"	7/8"	16 1/2"	9 1/16"	2 9/16"	3,600 lb	-
4011200HD	12"	12 3/4"	7/8"	18 5/8"	10 3/16"	3 1/16"	3,800 lb	-

410 Light Duty Clevis Hanger



Features

- Recommended for the suspension of stationary non-insulated pipe lines
- Conforms with U.S. Federal Specification WW-H-171 (Type 1), Manufacturers Standardization Society (MSS) SP-58 and SP-69 (Type 1)

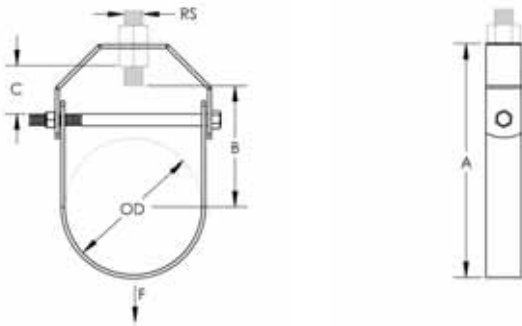

Specifications

Material: Steel
Finish: Electro-galvanized



Part Number	Pipe Size	Outer Diameter OD	Rod Size RS	A	B	C	Static Load F
4100050EG	1/2"	0.840"	3/8"	2 1/8"	1 1/16"	1/4"	150 lb
4100075EG	3/4"	1.050"	3/8"	2 3/8"	1 3/16"	3/8"	150 lb
4100100EG	1"	1.315"	3/8"	2 3/4"	1 1/2"	9/16"	250 lb
4100125EG	1 1/4"	1.660"	3/8"	3 5/16"	1 13/16"	11/16"	250 lb
4100150EG	1 1/2"	1.900"	3/8"	4"	2 3/8"	1 1/16"	250 lb
4100200EG	2"	2 3/8"	3/8"	4 1/2"	2 5/8"	1 1/8"	250 lb
4100250EG	2 1/2"	2 7/8"	1/2"	5 1/4"	3"	1 1/16"	350 lb
4100300EG	3"	3 1/2"	1/2"	6"	3 7/16"	7/8"	350 lb
4100350EG	3 1/2"	4"	1/2"	6 1/2"	3 11/16"	1 3/8"	400 lb
4100400EG	4"	4 1/2"	5/8"	7 3/4"	4 5/8"	1 3/4"	500 lb
4100500EG	5"	5 9/16"	5/8"	9 3/4"	5 5/8"	2 3/16"	600 lb
4100600EG	6"	6 5/8"	3/4"	11 3/4"	7 1/16"	2 11/16"	800 lb
4100800EG	8"	8 5/8"	3/4"	14"	8"	3 1/8"	1,200 lb



512 CADDY® EZ RISER for Close Quarters



Features

- Innovative design eliminates loose hardware, simplifying installation
- Serrated flange-head bolts eliminate need for wrenches on both bolt and nut
- Short ears allow for use in spaces where full-sized risers do not fit
- Conforms with Federal Specification WW-H-171 (Type 8), Manufacturers Standardization Society (MSS) SP-58 and SP-69 (Type 8)

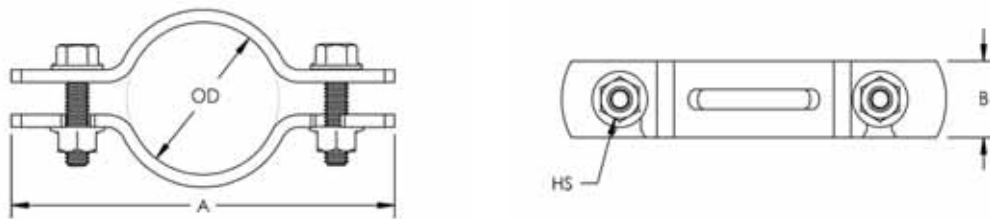

Specifications

Material: Steel

Finish: Electro-galvanized



Part Number	Pipe Size	Outer Diameter OD	Hole Size HS	A	B	Static Load F
5120100EG	1"	1.315"	7/16"	5"	1"	255 lb
5120125EG	1 1/4"	1.660"	7/16"	5 5/8"	1"	255 lb
5120150EG	1 1/2"	1.900"	7/16"	6 1/8"	1"	255 lb
5120200EG	2"	2 3/8"	7/16"	6 5/8"	1 3/16"	255 lb
5120250EG	2 1/2"	2 7/8"	7/16"	7 5/8"	1 3/16"	390 lb
5120300EG	3"	3 1/2"	9/16"	8 5/8"	1 3/16"	530 lb
5120400EG	4"	4 1/2"	9/16"	10 1/4"	1 1/2"	810 lb
5120500EG	5"	5 9/16"	9/16"	12 5/16"	1 1/2"	1,160 lb
5120600EG	6"	6 5/8"	9/16"	14 5/16"	2"	1,570 lb

510 CADDY® EZ RISER



Features

- Recommended for suspending vertical steel pipe risers
- Slotted holes make assembly easy, eliminating loose hardware
- Serrated flange-head bolts eliminate need for wrenches on both bolt and nut
- Conforms with Federal Specification WW-H-171 (Type 8), Manufacturers Standardization Society (MSS) SP-58 and SP-69 (Type 8)

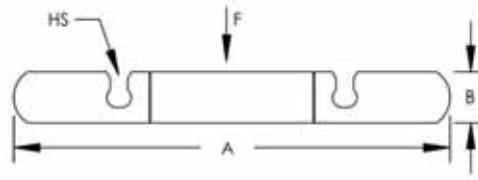
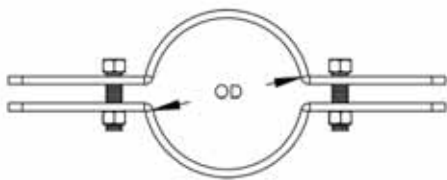

Specifications



Part Number	Pipe Size	Outer Diameter OD	Hole Size HS	A	B	Static Load F	Listings
Material: Steel – Finish: Electro-galvanized							
5100050EG	1/2"	0.840"	7/16"	8 1/2"	1"	255 lb	-
5100075EG	3/4"	1.050"	7/16"	9"	1"	255 lb	-
5100100EG	1"	1.315"	7/16"	9"	1"	255 lb	-
5100125EG	1 1/4"	1.660"	7/16"	9 7/16"	1"	255 lb	-
5100150EG	1 1/2"	1.900"	7/16"	9 7/8"	1"	255 lb	-
5100200EG	2"	2 3/8"	7/16"	10 1/4"	1 3/16"	255 lb	cUL, UL
5100250EG	2 1/2"	2 7/8"	7/16"	11"	1 3/16"	390 lb	cUL, UL
5100300EG	3"	3 1/2"	7/16"	11 3/4"	1 3/16"	530 lb	cUL, UL
5100350EG	3 1/2"	4"	9/16"	12 5/8"	1 3/16"	670 lb	cUL, UL
5100400EG	4"	4 1/2"	9/16"	13"	1 1/2"	810 lb	cUL, UL
5100500EG	5"	5 9/16"	9/16"	14 1/2"	1 1/2"	1,160 lb	cUL, UL
5100600EG	6"	6 5/8"	9/16"	16"	2"	1,570 lb	cUL, UL
5100800EG	8"	8 5/8"	11/16"	18 1/4"	2"	2,500 lb	cUL, UL



510 CADDY® EZ RISER

Part Number	Pipe Size	Outer Diameter OD	Hole Size HS	A	B	Static Load F	Listings
5101000EG	10"	10 3/4"	11/16"	20 5/8"	2"	2,500 lb	-
5101200EG	12"	12 3/4"	11/16"	22 3/8"	2"	2,700 lb	-
5101400EG	14"	14"	11/16"	24 1/8"	2"	2,700 lb	-
5101600EG	16"	16"	13/16"	27 7/8"	2 1/2"	2,900 lb	-
5101800EG	18"	18"	13/16"	29 13/16"	2 1/2"	2,900 lb	-
5102000EG	20"	20"	13/16"	32 1/4"	2 1/2"	2,900 lb	-
5102400EG	24"	24"	15/16"	36 1/8"	3"	2,900 lb	-
Material: Steel – Finish: Hot-dip galvanized							
5100050HD	1/2"	0.840"	7/16"	8 1/2"	1"	255 lb	-
5100100HD	1"	1.315"	7/16"	9"	1"	255 lb	-
5100125HD	1 1/4"	1.660"	7/16"	9 7/16"	1"	255 lb	-
5100150HD	1 1/2"	1.900"	7/16"	9 7/8"	1"	255 lb	-
5100200HD	2"	2 3/8"	7/16"	10 1/4"	1 3/16"	255 lb	cUL, UL
5100250HD	2 1/2"	2 7/8"	7/16"	11"	1 3/16"	390 lb	cUL, UL
5100300HD	3"	3 1/2"	7/16"	11 3/4"	1 3/16"	530 lb	cUL, UL
5100400HD	4"	4 1/2"	9/16"	13"	1 1/2"	810 lb	cUL, UL
5100500HD	5"	5 9/16"	9/16"	14 1/2"	1 1/2"	1,160 lb	cUL, UL
5100600HD	6"	6 5/8"	9/16"	16"	2"	1,570 lb	cUL, UL
5100800HD	8"	8 5/8"	11/16"	18 1/4"	2"	2,500 lb	cUL, UL
Material: Stainless steel 304							
5100050S4	1/2"	0.840"	7/16"	8 1/2"	1"	255 lb	-
5100075S4	3/4"	1.050"	7/16"	9"	1"	255 lb	-
5100100S4	1"	1.315"	7/16"	9"	1"	255 lb	-
5100125S4	1 1/4"	1.660"	7/16"	9 7/16"	1"	255 lb	-
5100150S4	1 1/2"	1.900"	7/16"	9 7/8"	1"	255 lb	-
5100200S4	2"	2 3/8"	7/16"	10 1/4"	1 3/16"	255 lb	cUL, UL
5100250S4	2 1/2"	2 7/8"	7/16"	11"	1 3/16"	390 lb	cUL, UL
5100300S4	3"	3 1/2"	7/16"	11 3/4"	1 3/16"	530 lb	cUL, UL
5100400S4	4"	4 1/2"	9/16"	13"	1 1/2"	810 lb	cUL, UL
5100500S4	5"	5 9/16"	9/16"	14 1/2"	1 1/2"	1,160 lb	cUL, UL
5100600S4	6"	6 5/8"	9/16"	16"	2"	1,570 lb	cUL, UL
5100800S4	8"	8 5/8"	11/16"	18 1/4"	2"	2,500 lb	cUL, UL
5101000S4	10"	10 3/4"	11/16"	20 5/8"	2"	2,500 lb	-

Clamp is fitted for steel pipe and should be installed below a coupling or shear lug, with bolts torqued to recommended value. Slotted holes and bolts for pipe sizes up to 12" only.

455 Malleable Split Ring Hanger

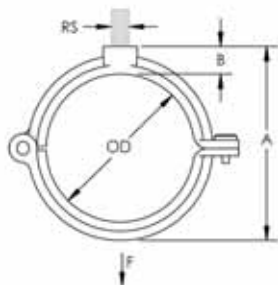

Features

- Recommended for the suspension of stationary non-insulated pipe lines
- Allows for piping runs close to ceiling or walls
- Conforms with Federal Specification WW-H-171 (Type 25), Manufacturers Standardization Society (MSS) SP-58 and SP-69 (Type 12)

Specifications

Material: Cast iron

Part Number	Pipe Size	Outer Diameter OD	Rod Size RS	A	B	Static Load F
Finish: Electro-galvanized						
4550037EG	3/8"	0.675"	3/8"	1 5/16"	3/8"	180 lb
4550050EG	1/2"	0.840"	3/8"	1 1/2"	3/8"	180 lb
4550075EG	3/4"	1.050"	3/8"	1 3/4"	7/16"	180 lb
4550100EG	1"	1.315"	3/8"	2"	7/16"	180 lb
4550125EG	1 1/4"	1.660"	3/8"	2 3/8"	1/2"	180 lb
4550150EG	1 1/2"	1.900"	3/8"	2 5/8"	1/2"	180 lb
4550200EG	2"	2 3/8"	3/8"	3 1/8"	1/2"	180 lb
4550250EG	2 1/2"	2 7/8"	1/2"	3 1/4"	5/8"	300 lb
4550300EG	3"	3 1/2"	1/2"	4 3/8"	5/8"	300 lb
4550400EG	4"	4 1/2"	1/2"	5 3/8"	11/16"	300 lb
Finish: Plain						
4550037PL	3/8"	0.675"	3/8"	1 5/16"	3/8"	180 lb
4550050PL	1/2"	0.840"	3/8"	1 1/2"	3/8"	180 lb
4550075PL	3/4"	1.050"	3/8"	1 3/4"	7/16"	180 lb
4550100PL	1"	1.315"	3/8"	2"	7/16"	180 lb
4550125PL	1 1/4"	1.660"	3/8"	2 3/8"	1/2"	180 lb
4550150PL	1 1/2"	1.900"	3/8"	2 5/8"	1/2"	180 lb
4550200PL	2"	2 3/8"	3/8"	3 1/8"	1/2"	180 lb
4550250PL	2 1/2"	2 7/8"	1/2"	3 1/4"	5/8"	300 lb
4550300PL	3"	3 1/2"	1/2"	4 3/8"	5/8"	300 lb
4550400PL	4"	4 1/2"	1/2"	5 3/8"	11/16"	300 lb

Bolt and rivet are carbon steel.



456 Malleable Split Ring Hanger for Copper Tube



Features

- Recommended for the suspension of stationary non-insulated copper tube lines
- Allows for piping runs close to ceiling or walls
- Conforms with Federal Specification WW-H-171 (Type 25), Manufacturers Standardization Society (MSS) SP-58 and SP-69 (Type 12)

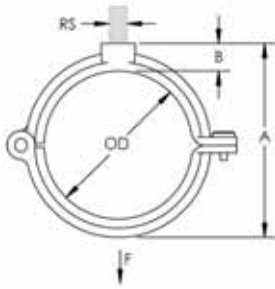

Specifications

Material: Cast iron
 Finish: Electro-galvanized
 Color: Brown

Part Number	Pipe Size	Outer Diameter OD	Rod Size RS	A	B	Static Load F
4560037CP	3/8"	0.675"	3/8"	15/16"	5/16"	180 lb
4560050CP	1/2"	0.840"	3/8"	1 1/8"	3/8"	180 lb
4560075CP	3/4"	1.050"	3/8"	1 3/8"	3/8"	180 lb
4560100CP	1"	1.315"	3/8"	1 5/8"	3/8"	180 lb
4560125CP	1 1/4"	1.660"	3/8"	1 7/8"	3/8"	180 lb
4560150CP	1 1/2"	1.900"	3/8"	2 1/8"	3/8"	180 lb
4560200CP	2"	2 3/8"	3/8"	2 5/8"	3/8"	180 lb
4560250CP	2 1/2"	2 7/8"	1/2"	3 3/8"	5/8"	180 lb
4560300CP	3"	3 1/2"	1/2"	3 7/8"	5/8"	180 lb
4560400CP	4"	4 1/2"	1/2"	5"	5/8"	180 lb

Bolt and rivet are carbon steel.

CPVC Hanging System



107 Wraparound Strap
for CPVC Pipe
Page 27



108 2-Hole Strap
for CPVC Pipe
Page 28



109 Side Mount Strap
for CPVC Pipe
Page 29



SOSR Stand Off 2-Hole Strap
for CPVC Pipe
Page 30



CADDY® MACROFIX PLUS NI
with Easy Closure
Page 31



3TW Fastener for
SOSR Series
Page 32

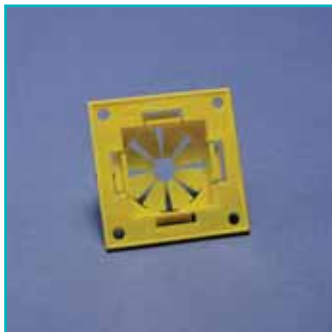

Easy Snap Grommet for
Factory Punched Holes
Page 32



Snap-On Nail Plate
Page 33



107 Wraparound Strap for CPVC Pipe



Features

- Includes flared edges to protect piping
- Rated for use with CPVC fire sprinkler pipe

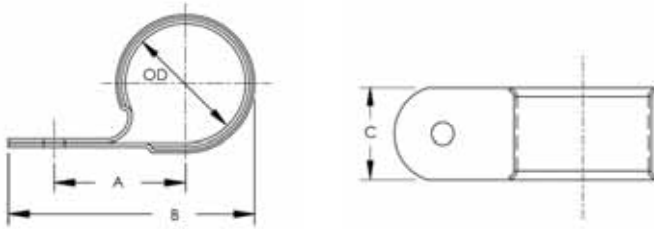

Specifications

Material: Steel

Finish: Pre-galvanized



Part Number	Pipe Size	Outer Diameter OD	Hole Size HS	A	B	C	Hanger Spacing
1070075EG	3/4"	1.050"	7/32"	1 1/4"	2 3/8"	1 3/16"	6' Max
1070100EG	1"	1.315"	7/32"	1 7/16"	2 11/16"	1 3/16"	6' Max
1070125EG	1 1/4"	1.660"	7/32"	1 5/8"	3 1/16"	1 3/16"	7' Max
1070150EG	1 1/2"	1.900"	7/32"	1 3/4"	3 5/16"	1 3/16"	7' Max
1070200EG	2"	2 3/8"	7/32"	1 7/8"	3 11/16"	1 3/16"	8' Max

108 2-Hole Strap for CPVC Pipe



CPVC HANGER SYSTEM

Features

- Includes flared edges to protect piping
- Rated for use with CPVC fire sprinkler pipe

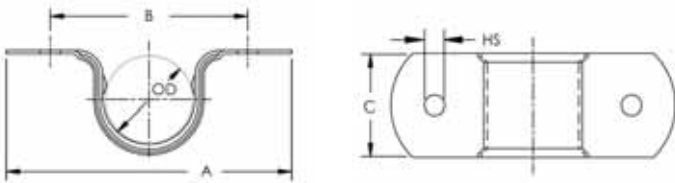

Specifications

Material: Steel
Finish: Pre-galvanized



Part Number	Pipe Size	Outer Diameter OD	Hole Size HS	A	B	C	Hanger Spacing
1080075EG	3/4"	1.050"	7/32"	3 1/4"	2 1/4"	1 3/16"	6' Max
1080100EG	1"	1.315"	7/32"	3 1/2"	2 1/2"	1 3/16"	6' Max
1080125EG	1 1/4"	1.660"	7/32"	4 1/4"	3 1/4"	1 3/16"	7' Max
1080150EG	1 1/2"	1.900"	7/32"	4 7/16"	3 7/16"	1 3/16"	7' Max
1080200EG	2"	2 3/8"	7/32"	4 15/16"	3 15/16"	1 3/16"	8' Max



109 Side Mount Strap for CPVC Pipe



Features

- Includes flared edges to protect piping
- Rated for use with CPVC fire sprinkler pipe

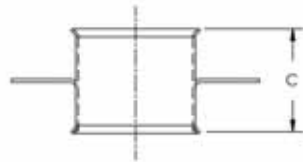
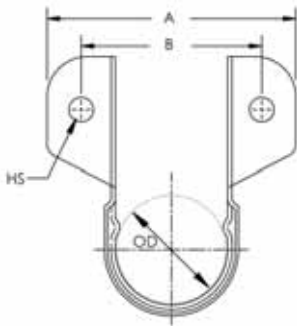

Specifications

Material: Steel

Finish: Pre-galvanized



Part Number	Pipe Size	Outer Diameter OD	Hole Size HS	A	B	C	Hanger Spacing
1090075EG	3/4"	1.050"	7/32"	2 5/16"	1 11/16"	1 3/16"	6' Max
1090100EG	1"	1.315"	7/32"	2 5/8"	1 15/16"	1 3/16"	6' Max
1090125EG	1 1/4"	1.660"	7/32"	2 15/16"	2 5/16"	1 3/16"	7' Max
1090150EG	1 1/2"	1.900"	7/32"	3 3/16"	2 1/2"	1 3/16"	7' Max
1090200EG	2"	2 3/8"	7/32"	3 5/8"	3"	1 3/16"	8' Max

SOSR Stand Off 2-Hole Strap for CPVC Pipe

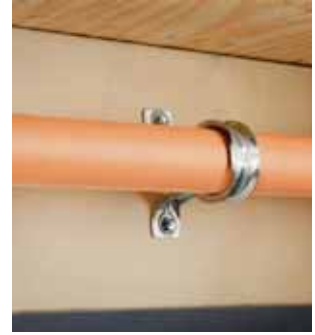

Features

- Includes flared edges to protect piping
- Rated for use with CPVC fire sprinkler pipe

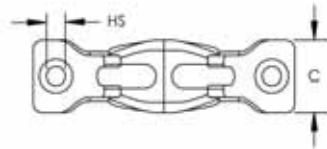
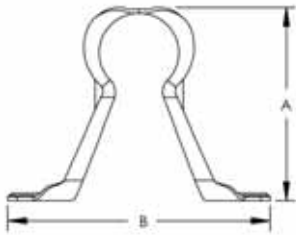

Specifications

Material: Steel
Finish: Pre-galvanized



Part Number	Pipe Size	Hole Size HS	A	B	C	Hanger Spacing	Standard Packaging Quantity	Listings
SOSR075	3/4"	0.2"	2 11/16"	3 5/8"	1"	6' Max	100 pc	cUL, UL
SOSR075B10	3/4"	0.2"	2 11/16"	3 5/8"	1"	6' Max	10 x 10 pc	-
SOSR100	1"	0.2"	2 15/16"	3 11/16"	1"	6' Max	100 pc	cUL, UL
SOSR100B10	1"	0.2"	2 15/16"	3 11/16"	1"	6' Max	10 x 10 pc	-
SOSR125	1 1/4"	0.2"	3 5/16"	3 5/8"	1"	6' Max	100 pc	cUL, UL
SOSR125B10	1 1/4"	0.2"	3 5/16"	3 5/8"	1"	6' Max	10 x 10 pc	-
SOSR150	1 1/2"	0.2"	3 7/8"	4 1/2"	1"	7' Max	100 pc	cUL, UL
SOSR150B10	1 1/2"	0.2"	3 7/8"	4 1/2"	1"	7' Max	10 x 10 pc	-
SOSR200	2"	0.2"	4"	5 1/4"	1"	8' Max	100 pc	cUL, UL
SOSR200B10	2"	0.2"	4"	5 1/4"	1"	8' Max	10 x 10 pc	-



CADDY® MACROFIX PLUS NI with Easy Closure



Features

- Contains easy closing mechanism
- Plastic washers help prevent crushing the CPVC or plastic pipe and assure a floating fit
- Flared edges and specially designed welding area help protect CPVC piping

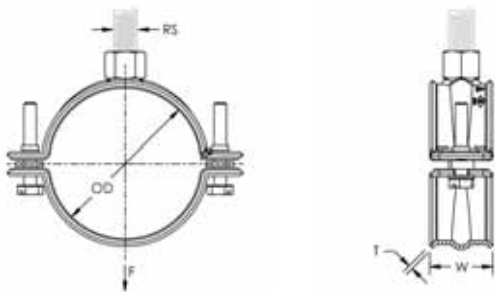

Specifications

Nut Included: Yes
 Material: Steel
 Finish: Electro-galvanized



Part Number	Pipe Size	Outer Diameter OD	Rod Size RS	Width W	Thickness T	Static Load F	Listings Approvals
4290050EG	1/2"	0.787" – 0.840"	3/8"	1 3/16"	1/16"	250 lb	cUL, UL
4290075EG	3/4"	0.984" – 1.059"	3/8"	1 3/16"	1/16"	250 lb	cUL, UL, FM
4290100EG	1"	1.260" – 1.327"	3/8"	1 3/16"	1/16"	250 lb	cUL, UL, FM
4290125EG	1 1/4"	1.575" – 1.669"	3/8"	1 3/16"	1/16"	250 lb	cUL, UL, FM
4290150EG	1 1/2"	1.900" – 1.969"	3/8"	1 3/16"	5/64"	380 lb	cUL, UL, FM
4290200EG	2"	2.374" – 2.480"	3/8"	1 3/16"	5/64"	380 lb	cUL, UL, FM
4290250EG	2 1/2"	2 7/8" – 2.996"	3/8"	1 3/16"	5/64"	380 lb	cUL, UL
4290300EG	3"	3 1/2" – 3.543"	3/8"	1 3/16"	5/64"	380 lb	cUL, UL
4290350EG	3 1/2"	4" – 4.106"	3/8"	1 3/16"	3/32"	440 lb	-
4290400EG	4"	4.331" – 4 1/2"	3/8"	1 3/16"	3/32"	440 lb	cUL, UL
4290500EG	5"	5 1/2" – 5.563"	3/8"	1 3/16"	3/32"	440 lb	-

3TW Fastener for SOSR Series

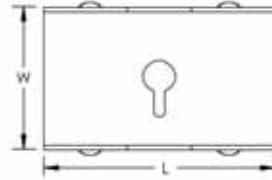
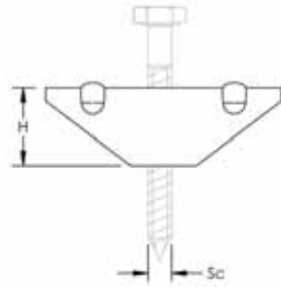

Features

- Backing nut for use with SOSR on composite wood joist installations

Specifications

Material: Steel

Finish: CADDY® ARMOUR

Part Number	Screw Diameter Sc	Height H	Length L	Width W
3TW	#10	7/16"	1 1/2"	1 1/4"

Easy Snap Grommet for Factory Punched Holes

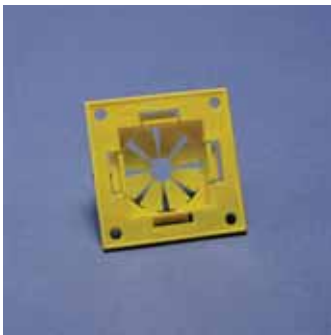

Features

- Snap grommet into a factory punched hole of any shape
- Provides anti-rattle protection
- Provides 360° protection of conduit, plumbing and fire sprinkler plumbing in metal studs

Specifications

Material: Polyethylene

Part Number	Copper Tube Size	EMT Conduit Size	Rigid Conduit/Pipe Size
ESGFP	1" Max	1/2", 3/4", 1"	1/2", 3/4", 1"



Snap-On Nail Plate



Features

- Protects electrical and mechanical installation through studs
- For wood and metal studs
- Press-on installation
- No tools required
- Breakable tabs permit multiple plates to be ganged together
- Holes on legs and surface of plate are provided to secure with nail or screw

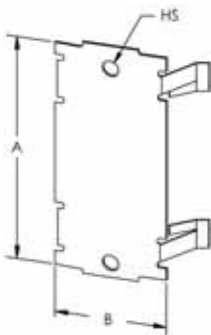

Specifications

Material: Steel
Finish: CADDY® ARMOUR



Part Number	Hole Size HS	A	B
304B2	3/16"	1 3/8"	3 1/8"

Pipe Supports



721 Pipe Support
with U-Bolt
Page 35



722 Adjustable
Pipe Support
Page 36



723 Adjustable
Pipe Support Assembly
Page 36



724 Adjustable Pipe Support
Assembly with U-Bolt
Page 37



721 Pipe Support with U-Bolt



Features

- Stanchion type support where vertical adjustment is not needed
- U-bolt provides additional stability

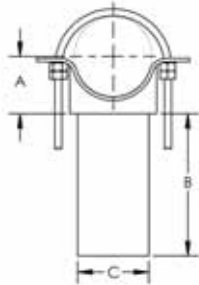

Specifications

Material: Steel
Finish: Plain

Part Number	Pipe Size	A	B	C
7210250PL	2 1/2"	3 5/8"	4"	1"
7210300PL	3"	3 7/8"	4"	2"
7210400PL	4"	4 3/16"	4"	3"
7210500PL	5"	4 13/16"	4"	3"
7210600PL	6"	5 7/16"	4"	3"
7210800PL	8"	6 15/16"	4"	3"
7211000PL	10"	8 7/16"	4"	3"
7211200PL	12"	9 15/16"	4"	3"
7211400PL	14"	10 15/16"	4"	4"
7211600PL	16"	12 3/8"	4"	4"
7211800PL	18"	13 7/8"	4"	4"
7212400PL	24"	17 15/16"	4"	6"

Install in accordance with applicable code.

722 Adjustable Pipe Support



Features

- NPT pipe welded to pipe saddle with a NPT pipe lock nut allowing for vertical adjustment in the pipe stanchion
- Conforms with Federal Specification WW-H-171 (Type 39), Manufacturers Standardization Society ANSI®/MSS-SP-58 (Type 38)

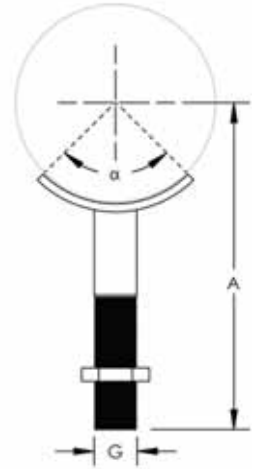

Specifications

Material: Steel

Finish: Plain

Part Number	Pipe Size	G	Angle	A
7220400PL	4"	1 1/2"	120 °	10 5/8"
7220600PL	6"	1 1/2"	120 °	11 11/16"
7220800PL	8"	1 1/2"	120 °	12 11/16"
7221000PL	10"	1 1/2"	120 °	13 3/4"

Install in accordance with applicable code.

723 Adjustable Pipe Support Assembly



Features

- Supports horizontal pipe from stanchions where vertical adjustment is needed
- Conforms with Federal Specification WW-H-171 (Type 38, 39), Manufacturers Standardization Society ANSI®/MSS-SP-58 (Type 38)

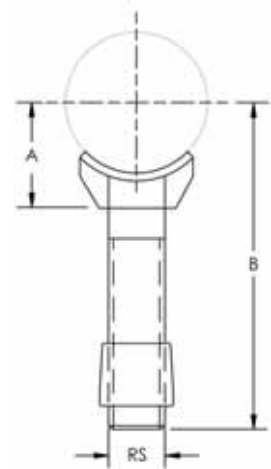

Specifications

Material: Steel

Finish: Plain

Part Number	Pipe Size	Rod Size RS	A	B
7230250PL	2 1/2"	1 1/2"	2 11/16"	7 15/16" – 12 7/16"
7230300PL	3"	1 1/2"	2 7/8"	8 1/8" – 12 5/8"
7230400PL	4"	2 1/2"	3 3/4"	9 7/16" – 13 15/16"
7230600PL	6"	2 1/2"	4 3/4"	10 7/16" – 14 15/16"
7230800PL	8"	2 1/2"	6 11/16"	12 3/8" – 16 7/8"

Gussets furnished on 8" and larger.
Install in accordance with applicable code.



724 Adjustable Pipe Support Assembly with U-Bolt



Features

- Supports horizontal pipe from stanchions where vertical adjustment is needed
- Conforms with Federal Specification WW-H-171 (Type 38, 39), Manufacturers Standardization Society ANSI®/MSS-SP-58 (Type 37, 38)

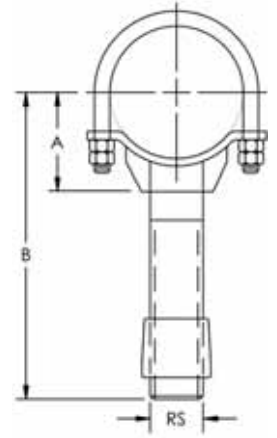

Specifications

Material: Steel

Finish: Plain

Part Number	Pipe Size	Rod Size RS	A	B
7240250PL	2 1/2"	1 1/2"	3 1/8"	8 3/8" – 12 7/8"
7240300PL	3"	1 1/2"	3 7/16"	8 11/16" – 13 3/16"
7240400PL	4"	2 1/2"	4 1/4"	9 15/16" – 14 7/16"
7240600PL	6"	2 1/2"	5 1/2"	11 3/16" – 15 11/16"
7240800PL	8"	2 1/2"	7"	12 11/16" – 17 3/16"
7241000PL	10"	2 1/2"	8"	13 11/16" – 18 3/16"
7241200PL	12"	2 1/2"	9 3/16"	14 7/8" – 19 3/8"

Gussets furnished on 8" and larger.
Install in accordance with applicable code.

CADDY® ROD LOCK



CADDY® ROD LOCK
Beam Clamp
Page 39



CADDY® ROD LOCK
Anchor Screw
Page 40



SN Series Nut
Page 41



CADDY® ROD LOCK Beam Clamp

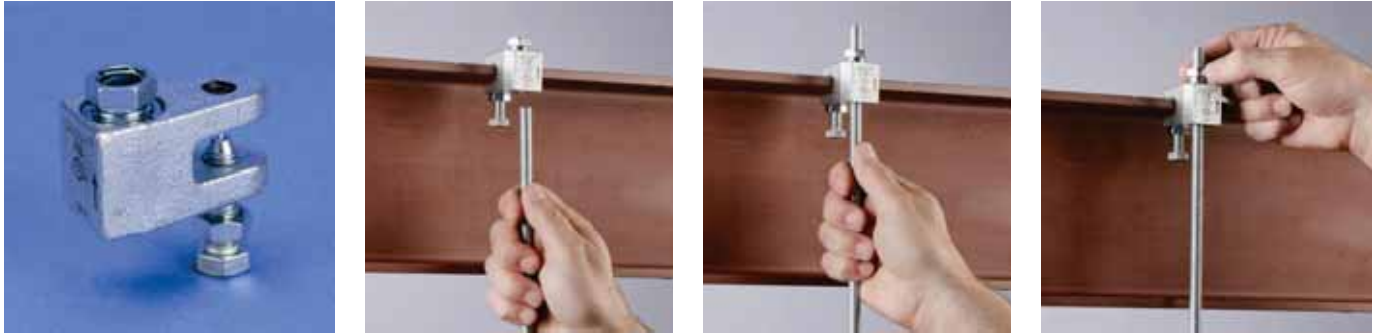

Features

- Easy "push-to-install" design allows installers to simply push the threaded rod through the mounting hole, instantly locking it into position
- Works with slightly damaged threads and minor burrs on the threaded rod
- Reduces installation time up to 60%

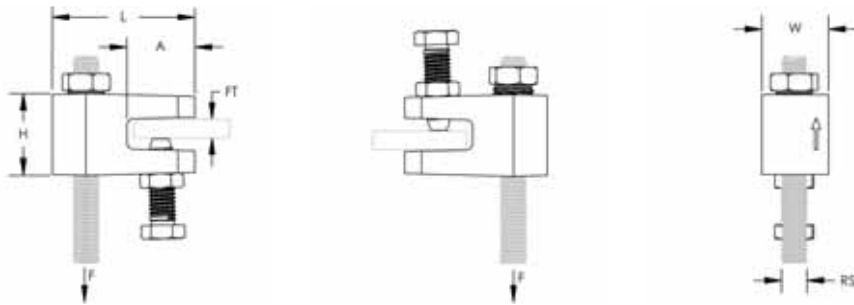

Specifications

Material: Cast iron
Finish: Electro-galvanized



Part Number	Rod Size RS	Flange Thickness FT	Height H	Length L	Width W	A	Static Load F
CRLB37EG	3/8"	1/8" – 7/16"	1 3/16"	2.06"	1"	0.98"	500 lb

For use on plain and electro zinc plated hardware only.

Recognizing that torque wrenches are generally not used or available on many job sites, the setscrew should be tightened so it contacts the I-beam and then an additional 1/2 turn added.

CADDY® ROD LOCK Anchor Screw



Features

- For use with concrete and solid brick
- Works with slightly damaged threads and minor burrs on the threaded rod
- Reduces installation time up to 35%

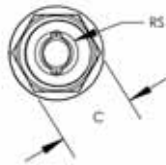
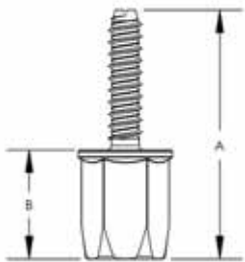

Specifications

Material: Steel
Finish: Electro-galvanized



Part Number	Rod Size RS	A	B	C	Drill Bit Size	Drill Hole Depth	Static Load F
CRLA37EG	3/8"	2 7/8"	1 1/4"	7/8"	5/16"	2"	660 lb

For use on plain and electro zinc plated hardware only.
Tested in 3000 psi (20.67 Mpa) concrete.

CADDY® ROD LOCK



SN Series Nut



Features

- Allows side mounting of nut to threaded rod
- Reduces the need for threading compared to standard nuts and washers
- Ideal for retrofit projects, such as trapeze installations
- Works with slightly damaged threads and minor burrs on the threaded rod
- Reduces installation time up to 50%

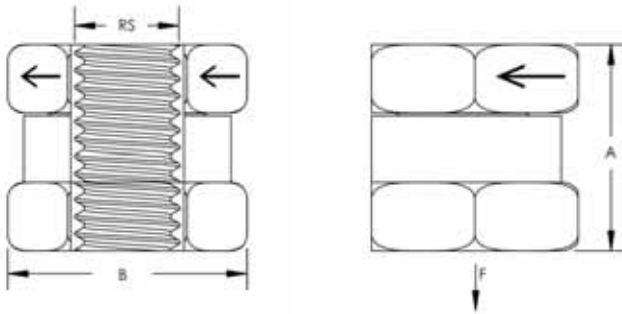

Specifications

Material: Steel

Finish: Electro-galvanized

Part Number	Rod Size RS	A	B	Static Load F
SN25	1/4"	3/4"	7/8"	500 lb
SN37	3/8"	3/4"	7/8"	1,350 lb
SN50	1/2"	3/4"	7/8"	2,250 lb

For use on plain and electro zinc plated hardware only.

Structural Attachments



300 Universal Beam Clamp
Page 44



310 Universal Beam Clamp,
Wide Mouth
Page 45



305 Stainless Steel
Top-Mount Beam Clamp
Page 46

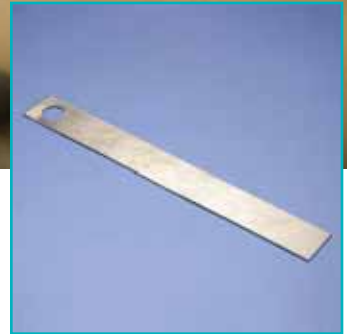

300C Standard
Retainer Strap
Page 47



34SL Retrofit
Retainer Strap
Page 48



PH Multi-Purpose
Purlin Clamp
Page 49



PHSW Multi-Purpose
Purlin Clamp with Swivel
Page 50



315 Malleable Iron
Purlin Clamp
Page 51





547/548 C-Clamp
Page 21

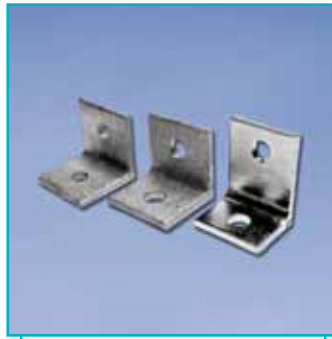

325 Steel
Side Beam Attachment
Page 52



327 Malleable Iron
Side Beam Attachment
Page 53



326 Universal Steel
Side Beam Attachment
Page 54



329 Side Beam Attachment
Page 55



328 Threaded Steel
Side Beam Attachment
Page 56



37 Steel Eye Socket
Rod Hanger
Page 57



38 Offset Steel
Eye Socket Rod Hanger
Page 58



365 Steel Wall or
Ceiling Plate
Page 59



365M Malleable Iron Wall
or Ceiling Plate
Page 60



352 Standard Duty
Welded Wall Bracket
Page 61



353 Heavy Duty
Welded Wall Bracket
Page 62



370A Single Concrete
Insert Plate and Rod
Page 63



355 Concrete Insert Plate
Page 64

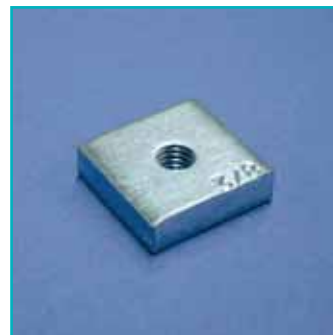

355N Nut for 355 Series
Page 65

300 Universal Beam Clamp



Features

- Conforms with Federal Specification WW-H-171 (Type 23), Manufacturers Standardization Society ANSI®/MSS-SP-58 (Type 19 and 23), install in accordance with ANSI/MSS-SP-69

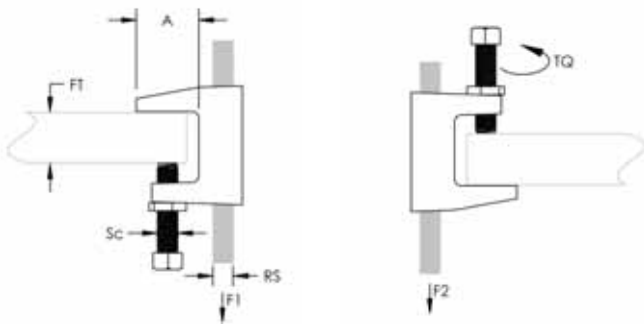

Specifications

Material: Steel



Part Number	Rod Size RS	Flange Thickness FT	A	Screw Diameter Sc	Torque TQ	Static Load 1 F1	Static Load 2 F2	Standard Packaging Quantity	Listings Approvals
Finish: Electro-galvanized									
3000037EG	3/8"	13/16" Max	1 1/8"	3/8"	5 ft lb	500 lb	250 lb	100 pc	cUL, UL, FM
3000050EG	1/2"	13/16" Max	1 1/8"	7/16"	8 ft lb	950 lb	760 lb	50 pc	cUL, UL, FM
3000062EG	5/8"	13/16" Max	1 1/8"	3/8"	5 ft lb	950 lb	760 lb	50 pc	cUL, UL
3000075EG	3/4"	13/16" Max	1 1/8"	3/8"	5 ft lb	950 lb	760 lb	50 pc	cUL, UL
3000087EG	7/8"	13/16" Max	1 1/8"	3/8"	5 ft lb	950 lb	760 lb	50 pc	cUL, UL
Finish: Plain									
3000037PL	3/8"	13/16" Max	1 1/8"	3/8"	5 ft lb	500 lb	250 lb	100 pc	cUL, UL, FM
3000050PL	1/2"	13/16" Max	1 1/8"	7/16"	8 ft lb	950 lb	760 lb	50 pc	cUL, UL, FM
3000062PL	5/8"	13/16" Max	1 1/8"	3/8"	5 ft lb	950 lb	760 lb	50 pc	cUL, UL
3000075PL	3/4"	13/16" Max	1 1/8"	3/8"	5 ft lb	950 lb	760 lb	50 pc	cUL, UL
3000087PL	7/8"	13/16" Max	1 1/8"	3/8"	5 ft lb	950 lb	760 lb	50 pc	cUL, UL

Setscrew must be tightened and torqued onto the sloped side of the I-beam.

Recognizing that torque wrenches are generally not used or available on many job sites, the setscrew should be tightened so it contacts the I-beam and then an additional 1/4 to 1/2 turn added.



310 Universal Beam Clamp, Wide Mouth



Features

- Universal beam clamp for thick beams
- Conforms with Federal Specification WW-H-171 (Type 23), Manufacturers Standardization Society ANSI®/MSS-SP-58 (Type 19 and 23), install in accordance with ANSI/MSS-SP-69

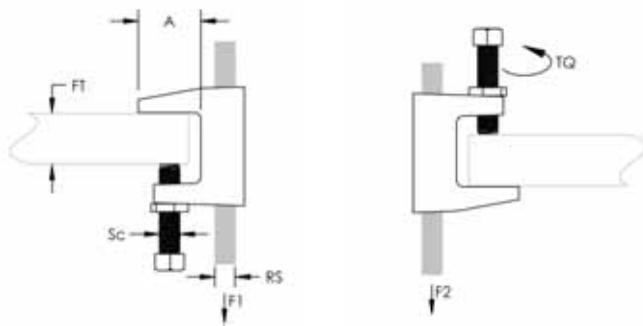

Specifications

Material: Steel

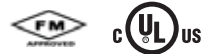

Part Number	Rod Size RS	Flange Thickness FT	A	Screw Diameter Sc	Torque TQ	Static Load 1 F1	Static Load 2 F2
Finish: Electro-galvanized							
3100037EG	3/8"	1 1/4" Max	1"	3/8"	5 ft lb	500 lb	250 lb
3100050EG	1/2"	1 1/4" Max	1"	1/2"	11 ft lb	950 lb	760 lb
Finish: Plain							
3100037PL	3/8"	1 1/4" Max	1"	3/8"	5 ft lb	500 lb	250 lb
3100050PL	1/2"	1 1/4" Max	1"	1/2"	11 ft lb	950 lb	760 lb

Setscrew must be tightened and torqued onto the sloped side of the I-beam.

Recognizing that torque wrenches are generally not used or available on many job sites, the setscrew should be tightened so it contacts the I-beam and then an additional 1/4 to 1/2 turn added.

305 Stainless Steel Top-Mount Beam Clamp



Features

- Pressed steel beam clamp
- Conforms with Federal Specification WW-H-171 (Type 23), Manufacturers Standardization Society ANSI®/MSS-SP-58 (Type 19 and 23), install in accordance with ANSI/MSS-SP-69 •Structural attachment to top flange of metal beams, purlins, channel, or angle iron

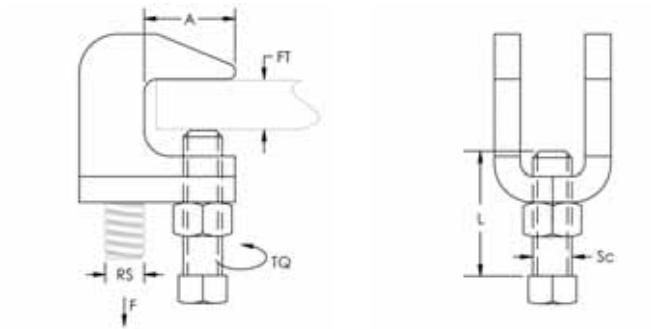

Specifications

Material: Stainless steel 304

Part Number	Rod Size RS	Flange Thickness FT	A	Screw Diameter Sc	Screw Length L	Torque TQ	Static Load F
3050037S4	3/8"	5/8" Max	7/8"	3/8"	1 1/2"	5 ft lb	500 lb
3050050S4	1/2"	5/8" Max	7/8"	3/8"	1 1/2"	5 ft lb	1,130 lb

Set screw must be tightened and torqued onto the sloped side of the I-beam, channel, or angle iron flange.

Recognizing that torque wrenches are generally not used or available on many job sites, the setscrew should be tightened so it contacts the I-beam and then an additional 1/4 to 1/2 turn added.



300C Standard Retainer Strap

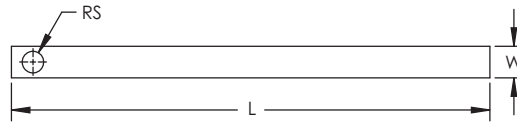

Features

- Retainer strap for beam clamps

Specifications

Material: Steel

Finish: Electro-galvanized

Part Number	Rod Size	Length	Width
300C3706EG	3/8"	6"	15/16"
300C3708EG	3/8"	8"	15/16"
300C3710EG	3/8"	10"	15/16"
300C3712EG	3/8"	12"	15/16"
300C3714EG	3/8"	14"	15/16"
300C3716EG	3/8"	16"	15/16"
300C3718EG	3/8"	18"	15/16"
300C5008EG	1/2"	8"	15/16"
300C5010EG	1/2"	10"	15/16"
300C5012EG	1/2"	12"	15/16"
300C5014EG	1/2"	14"	15/16"
300C5016EG	1/2"	16"	15/16"
300C6206EG	5/8"	6"	1 3/16"
300C6208EG	5/8"	8"	1 3/16"
300C6210EG	5/8"	10"	1 3/16"
300C6212EG	5/8"	12"	1 3/16"
300C6214EG	5/8"	14"	1 3/16"
300C7506EG	3/4"	6"	1 3/16"
300C7508EG	3/4"	8"	1 3/16"
300C7510EG	3/4"	10"	1 3/16"
300C7514EG	3/4"	14"	1 3/16"
300C8706EG	7/8"	6"	2"
300C8708EG	7/8"	8"	2"
300C8714EG	7/8"	14"	2"

Field bend and use jam nut over hanger rod to secure.
Add 2" to width of flange to determine minimum length strap required.

34SL Retrofit Retainer Strap



Features

- Retrofit retainer strap for beam clamps

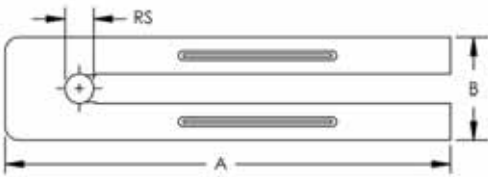

Specifications

Material: Steel

Finish: Electro-galvanized



Part Number	Rod Size RS	A	B
034SL0600EG	3/8"	6"	1 3/8"
034SL0800EG	3/8"	8"	1 3/8"
034SL1000EG	3/8"	10"	1 3/8"
034SL1200EG	3/8"	12"	1 3/8"
034SL1400EG	3/8"	14"	1 3/8"

Field bend and use jam nut over hanger rod to secure.
Add 2" to width of flange to determine minimum length strap required.



PH Multi-Purpose Purlin Clamp



Features

- Attaches to bottom of purlins and beams to support threaded rod

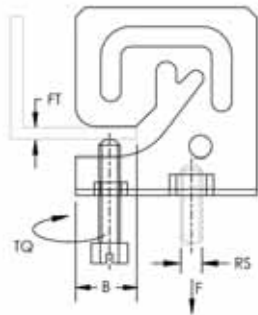

Specifications

Material: Steel

Finish: Electro-galvanized



Part Number	Rod Size RS	Flange Thickness FT	B	Torque TQ	Static Load 1 F1	Static Load 2 F2	Nut Included
PH4	1/4"	1/4" Max	3/4" Min	30 in lb	200 lb	160 lb	No
PH6	3/8"	1/4" Max	3/4" Min	30 in lb	200 lb	160 lb	No
PH6FP	3/8"	1/4" Max	3/4" Min	30 in lb	200 lb	-	Yes

A jam nut is required for fire protection applications.

Refer to Static Load 1 when attaching to C and Z purlins. Refer to Static Load 2 when attaching to a flat flange.

Recognizing that torque wrenches are generally not used or available on many job sites, the setscrew should be tightened so it contacts the I-beam and then an additional 1/4 to 1/2 turn added.

PHSW Multi-Purpose Purlin Clamp with Swivel



Features

- Attachment to bottom of purlins and beams to support threaded rod
- Swivel feature option for attachment to purlins under sloped roofs

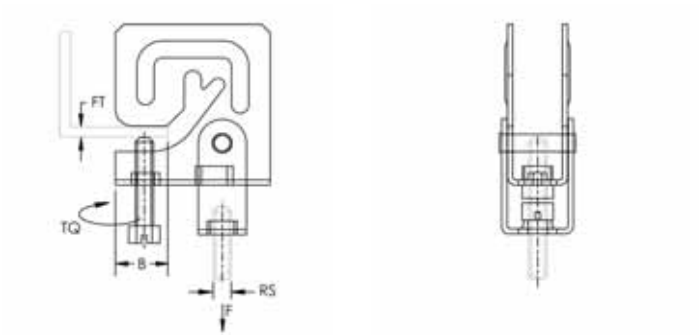

Specifications

Material: Steel

Finish: Electro-galvanized



Part Number	Rod Size RS	Flange Thickness FT	B	Torque TQ	Static Load 1 F1	Static Load 2 F2	Nut Included
PHSW4	1/4"	1/4" Max	3/4" Min	30 in lb	200 lb	160 lb	No
PHSW6	3/8"	1/4" Max	3/4" Min	30 in lb	200 lb	160 lb	No
PHSW6FP	3/8"	1/4" Max	3/4" Min	30 in lb	200 lb	-	Yes

A jam nut is required for fire protection applications.

Refer to Static Load 1 when attaching to C and Z purlins. Refer to Static Load 2 when attaching to a flat flange.

Recognizing that torque wrenches are generally not used or available on many job sites, the setscrew should be tightened so it contacts the I-beam and then an additional 1/4 to 1/2 turn added.



315 Malleable Iron Purlin Clamp



Features

- Attaches to lower flange of metal beams or purlins
- Supports 45° flanges up to 2" long, and 90° flanges up to 1-1/2" high

Specifications

Material: Cast iron

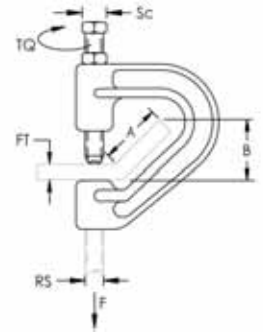

Part Number	Rod Size RS	Flange Thickness FT	A	B	Screw Diameter Sc	Torque TQ	Pipe Size	Static Load F
Finish: Electro-galvanized								
3150037EG	3/8"	1" Max	2"	1 1/2"	3/8"	5 ft lb	4" Max	400 lb
Finish: Plain								
3150037PL	3/8"	1" Max	2"	1 1/2"	3/8"	5 ft lb	4" Max	400 lb

Setscrew must be tightened and torqued onto the sloped side of the I-beam.

Install in accordance with applicable code.

Recognizing that torque wrenches are generally not used or available on many job sites, the setscrew should be tightened so it contacts the I-beam and then an additional 1/4 to 1/2 turn added.

547/548 C-Clamp



Features

- For use on steel beams and purlins

Specifications

Material: Steel

Finish: Plain

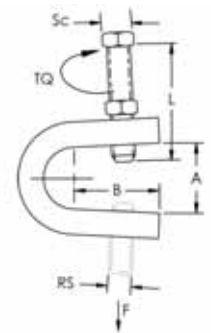

Part Number	Rod Size RS	A	B	Screw Diameter Sc	Screw Length L	Torque TQ	Static Load F	Listings Approvals
5470037PL	3/8"	1"	1 5/16"	3/8"	1 3/4"	5 ft lb	250 lb	cUL, UL, FM
5480050PL	1/2"	1 1/8"	1 1/4"	1/2"	1 3/4"	11 ft lb	250 lb	FM

Setscrew must be tightened and torqued onto the sloped side of the I-beam.

Recognizing that torque wrenches are generally not used or available on many job sites, the setscrew should be tightened so it contacts the I-beam and then an additional 1/4 to 1/2 turn added.

325 Steel Side Beam Attachment

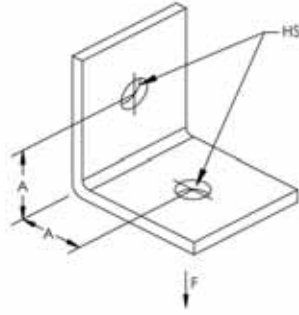
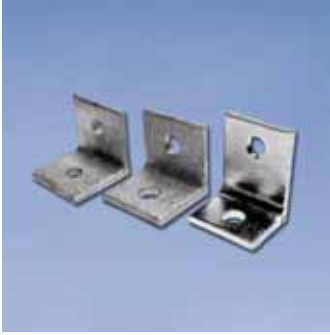

Features

- Fastens to the wall or the side of a joist to support hanger rod
- Conforms with Federal Specification WW-H-171 (Type 35), Manufacturers Standardization Society ANSI®/MSS-SP-58 (Type 34)

Specifications

Material: Steel

Part Number	Rod Size RS	Hole Size HS	Hole Type	A	Static Load 1 F1	Static Load 2 F2
Finish: Electro-galvanized						
3250037EG	3/8"	7/16"	Plain	1 5/32"	650 lb	1,150 lb
3250050EG	1/2"	9/16"	Plain	1 5/32"	650 lb	1,150 lb
3250062EG	5/8"	11/16"	Plain	1 3/8"	850 lb	2,000 lb
3250075EG	3/4"	13/16"	Plain	1 3/4"	900 lb	3,500 lb
3250087EG	7/8"	15/16"	Plain	2 1/2"	900 lb	3,600 lb
3250100EG	1"	1 1/16"	Plain	2 1/2"	900 lb	3,700 lb
Finish: Plain						
3250037PL	3/8"	7/16"	Plain	1 5/32"	650 lb	1,150 lb
3250050PL	1/2"	9/16"	Plain	1 5/32"	650 lb	1,150 lb
3250062PL	5/8"	11/16"	Plain	1 3/8"	850 lb	2,000 lb
3250075PL	3/4"	13/16"	Plain	1 3/4"	900 lb	3,500 lb
3250087PL	7/8"	15/16"	Plain	2 1/2"	900 lb	3,600 lb
3250100PL	1"	1 1/16"	Plain	2 1/2"	900 lb	3,700 lb

Refer to Static Load 1 when used with lag screw. Refer to Static Load 2 with bolt to steel.

Follow fastener manufacturer's recommended shear and pull-out strength when fastening to the structure. Fastener not included.

Install in accordance with applicable code.



327 Malleable Iron Side Beam Attachment



Features

- Pre-threaded structural attachment fastened to wall or the side of a joist to support hanger rod where two #43 Wood Drive Screws are necessary for proper support

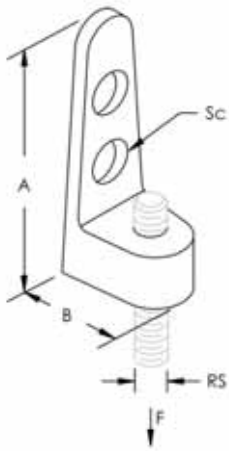

Specifications

Material: Steel

Part Number	Rod Size RS	A	B	Screw Diameter Sc	Static Load F
Finish: Electro-galvanized					
3270037EG	3/8"	2 3/8"	15/16"	#14	250 lb
3270050EG	1/2"	2 3/4"	1 5/16"	#16	480 lb
Finish: Plain					
3270037PL	3/8"	2 3/8"	15/16"	#14	250 lb
3270050PL	1/2"	2 3/4"	1 5/16"	#16	480 lb

Load rating dependent on wood structure strength.

Follow fastener manufacturer's recommended shear and pull-out strength when fastening to the structure. Fastener not included.

326 Universal Steel Side Beam Attachment



Features

- Fastens to the wall or the side of a joist to support hanger rod
- Either 3/8" or 1/2" fasteners can be used to reduce inventories
- Conforms with Federal Specification WW-H-171 (Type 35), Manufacturers Standardization Society ANSI®/MSS-SP-58 (Type 34)

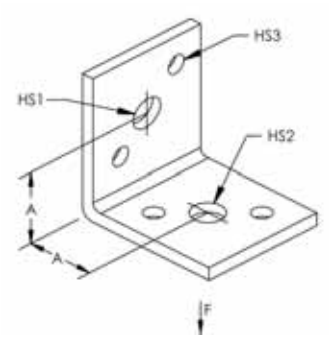

Specifications

Material: Steel

Part Number	Hole Size 1 HS1	Hole Size 2 HS2	Hole Size 3 HS3	A	Static Load 1 F1	Static Load 2 F2
Finish: Electro-galvanized						
3260037EG	7/16"	9/16"	9/32"	1 5/32"	560 lb	620 lb
Finish: Plain						
3260037PL	7/16"	9/16"	9/32"	1 5/32"	560 lb	620 lb

Refer to Static Load 1 when used with lag screw. Refer to Static Load 2 with bolt to steel.

Follow fastener manufacturer's recommended shear and pull-out strength when fastening to the structure. Fastener not included.

Install in accordance with applicable code.



329 Side Beam Attachment



Features

- Supports pipe from wood, concrete or steel structures
- Pre-threaded

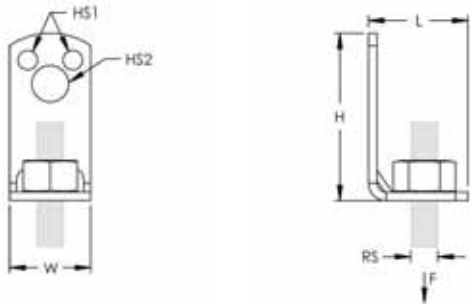

Specifications

Material: Steel

Finish: Electro-galvanized



Part Number	Rod Size RS	Hole Size 1 H51	Hole Size 2 H52	Height H	Length L	Width W	Static Load F
3290037EG	3/8"	0.276"	0.51"	2.31"	1.1"	1.102"	350 lb

Structure	Fastener Type	Fastener Quantity	UL Nominal Pipe Size	FM Nominal Pipe Size
Wood (Pre-drilling not Required)	#14 x 2" Drive Screw	2	2" Max	3" Max
	1/4" x 1 1/2" Lag Bolt	2	2" Max	3" Max
	1/4" x 2" Lag Bolt	2	2" Max	3 1/2" Max
	3/8" x 3" Lag Bolt, Washer	1	2" Max	3 1/2" Max
Wood (1/4" Pilot Hole Required)	1/2" x 3" Lag Bolt	1	4" Max	4" Max
Steel (Minimum 16 GA)	3/8" Bolt, Washer, Nut	1	4" Max	4" Max
	1/4" x 1" Self Drill & Tap Screw	2	4" Max	4" Max
Concrete	3/8" Bolt	1	4" Max	4" Max

Install in accordance with applicable code.

328 Threaded Steel Side Beam Attachment



Features

- Fastens to wall or the side of a joist to support hanger rod
- Pre-threaded
- Conforms with Federal Specification WW-H-171 (Type 35), Manufacturers Standardization Society ANSI®/MSS-SP-58 (Type 34)

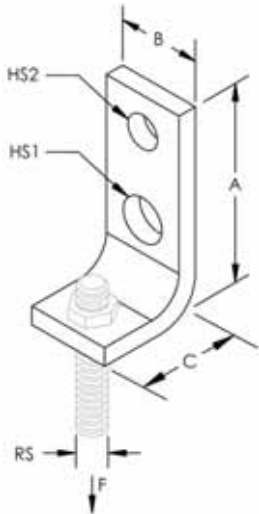

Specifications

Material: Steel



Part Number	Rod Size RS	Hole Size 1 HS1	Hole Size 2 HS2	A	B	C	Static Load 1 F1	Static Load 2 F2
Finish: Electro-galvanized								
3280037EG	3/8"	17/32"	13/32"	2 9/16"	1"	1 1/4"	560 lb	620 lb
Finish: Plain								
3280037PL	3/8"	17/32"	13/32"	2 9/16"	1"	1 1/4"	560 lb	620 lb
3280050PL	1/2"	17/32"	13/32"	2 9/16"	1"	1 1/4"	560 lb	620 lb

Refer to Static Load 1 when used with lag screw. Refer to Static Load 2 with bolt to steel.
Follow fastener manufacturer's recommended shear and pull-out strength when fastening to the structure. Fastener not included.
Install in accordance with applicable code.



37 Steel Eye Socket Rod Hanger



Features

- Joins hanger rod to a structure

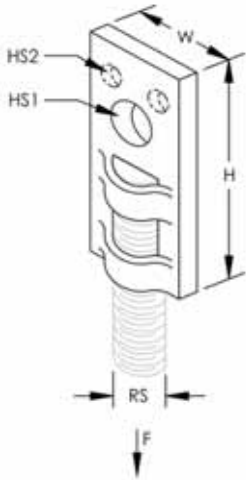

Specifications

Material: Steel

Finish: Pre-galvanized



Part Number	Rod Size RS	Pipe Size	Hole Size 1 HS1	Hole Size 2 HS2	Height H	Width W	Static Load F
0370037EG	3/8"	3/4" – 4"	1/2"	1/4"	2 1/4"	1 1/8"	250 lb
0370050EG	1/2"	2 1/2" – 6"	11/16"	-	2 3/4"	1 1/2"	760 lb

Load rating dependent on wood structure strength.

38 Offset Steel Eye Socket Rod Hanger



Features

- Structural attachment used to join hanger rod to a structure
- Provides full vertical rod adjustment

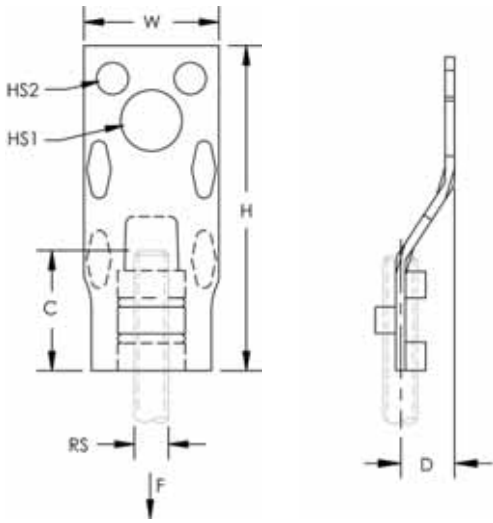

Specifications

Material: Steel

Finish: Electro-galvanized



Part Number	Rod Size RS	Pipe Size	Hole Size 1 HS1	Hole Size 2 HS2	Height H	Width W	C	D	Static Load F
0380037EG	3/8"	4" Max	1/2"	1/4"	3 1/4"	1 1/8"	1 3/16"	3/4"	250 lb

Load rating dependent on wood structure strength.

For 3/8" rod through 2" pipe, use two Model #43 Wood Drive Screws. For 3/8" rod through 4" pipe, use one Model #42 1/2" x 3" Lag Screw.



365 Steel Wall or Ceiling Plate



Features

- Structural attachment to support hanger rod from a ceiling or a wall

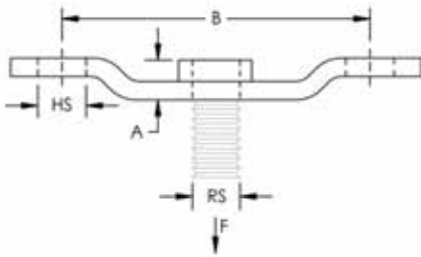

Specifications

Material: Steel

Part Number	Rod Size RS	Hole Size HS	A	B	Pipe Size	Static Load F
Finish: Electro-galvanized						
3650037EG	3/8"	5/16"	5/16"	2 1/4"	2" Max	100 lb
Finish: Copper electro plated						
3650037CP	3/8"	5/16"	5/16"	2 1/4"	2" Max	100 lb
Finish: Plain						
3650037PL	3/8"	5/16"	5/16"	2 1/4"	2" Max	100 lb

Follow fastener manufacturer's recommended shear and pull-out strength when fastening to the structure. Fastener not included.

365M Malleable Iron Wall or Ceiling Plate



Features

- Structural attachment to support hanger rod from a ceiling or a wall

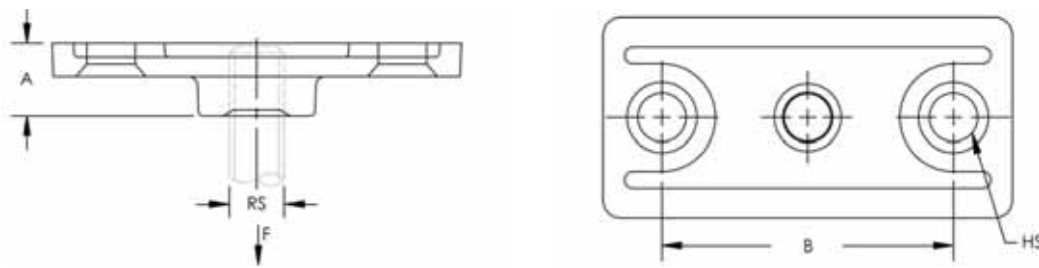

Specifications

Material: Cast iron

Part Number	Rod Size RS	Hole Size HS	A	B	Pipe Size	Static Load F
Finish: Electro-galvanized						
365M0037EG	3/8"	5/16"	15/32"	1 15/16"	2" Max	180 lb
365M0050EG	1/2"	5/16"	15/32"	1 15/16"	3 1/2" Max	180 lb
Finish: Copper electro plated						
365M0037CP	3/8"	5/16"	15/32"	1 15/16"	2" Max	180 lb
365M0050CP	1/2"	5/16"	15/32"	1 15/16"	3 1/2" Max	180 lb
Finish: Plain						
365M0037PL	3/8"	5/16"	15/32"	1 15/16"	2" Max	180 lb
365M0050PL	1/2"	5/16"	15/32"	1 15/16"	3 1/2" Max	180 lb

Follow fastener manufacturer's recommended shear and pull-out strength when fastening to the structure. Fastener not included.



352 Standard Duty Welded Wall Bracket



Features

- Wall attachment to support or suspend static piping
- Conforms with Federal Specification WW-H-171 (Type 32), Manufacturers Standardization Society ANSI®/MSS-SP-58 (Type 32)

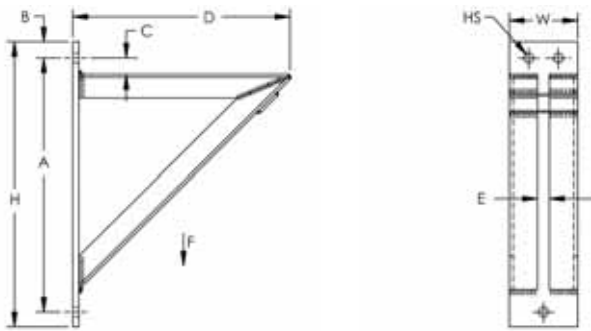

Specifications

Material: Steel

Finish: Plain

Part Number	Height H	Width W	A	B	C	D	E	Hole Size HS	Static Load F
3520100PL	18"	4"	15 1/2"	1 1/4"	1 1/4"	12"	1"	13/16"	1,500 lb
3520200PL	24"	4 1/2"	21 1/2"	1 1/4"	1 1/4"	18"	1"	13/16"	1,500 lb
3520300PL	30"	5"	27 1/2"	1 1/4"	1 1/4"	24"	1"	13/16"	1,500 lb

Follow fastener manufacturer's recommended shear and pull-out strength when fastening to the structure. Fastener not included.
Install in accordance with applicable code.

353 Heavy Duty Welded Wall Bracket



Features

- Wall attachment to support or suspend static piping
- Conforms with Federal Specification WW-H-171 (Type 33), Manufacturers Standardization Society ANSI®/MSS-SP-58 (Type 33)

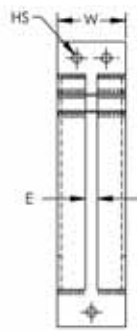
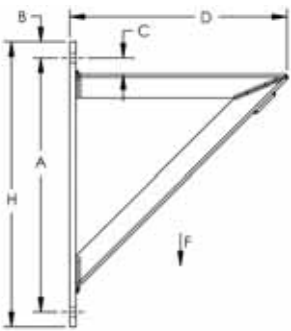

Specifications

Material: Steel

Finish: Plain

Part Number	Height H	Width W	A	B	C	D	E	Hole Size HS	Static Load F
3530100PL	18"	4"	15 1/4"	1 1/2"	7/8"	12"	1"	13/16"	3,000 lb
3530200PL	24"	5"	21 3/8"	1 3/8"	1"	18"	1"	15/16"	3,000 lb
3530300PL	30"	5"	27 1/2"	1 1/4"	1 1/8"	24"	1"	1 1/16"	3,000 lb
3530400PL	36"	5"	33 1/4"	1 1/2"	1 1/2"	30"	1"	1 1/16"	3,000 lb

Follow fastener manufacturer's recommended shear and pull-out strength when fastening to the structure. Fastener not included.
Install in accordance with applicable code.



370A Single Concrete Insert Plate and Rod



Features

- Used to support hanger rod from metal deck-poured concrete ceiling
- For use when adjustment for concrete thickness is needed

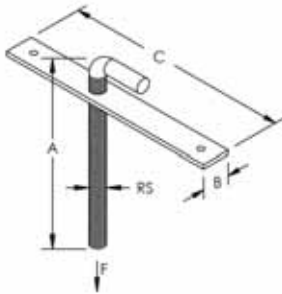

Specifications

Material: Steel

Finish: Plain

Part Number	Rod Size RS	A	B	C	Static Load F
370A0037PL	3/8"	8"	1 1/4"	10"	240 lb
370A0050PL	1/2"	8"	1 1/4"	10"	240 lb
370A0062PL	5/8"	8"	1 1/4"	10"	610 lb

Threaded rod supplied with an Electro Zinc Plated finish.

Maximum load ratings are dependent on many factors, which include, but are not limited to: type of concrete, depth of slab, location of anchor in slab, and depth of anchor in slab. Consult a professional engineer regarding anchor positioning.

355 Concrete Insert Plate



Features

- Structural attachment in all grades of concrete
- Knockout keeps interior empty during pour
- Allows for horizontal rod adjustment up to 1-1/4"
- 355N Nut required for UL Listing and FM Approval
- Conforms with Federal Specification WW-H-171 (Type 19), Manufacturers Standardization Society ANSI®/MSS-SP-58 (Type 18)

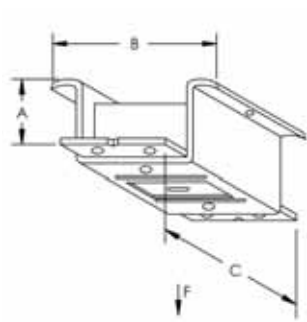

Specifications

Material: Steel
Finish: Plain



Part Number	Rod Size RS	A	B	C	Pipe Size	Static Load F
3550000PL	3/8", 1/2", 5/8", 3/4", 7/8"	1 5/8"	3 9/16"	3"	10" Max	1,200 lb

Rod should be threaded through the nut until it tightens against the top of the insert.

For installation, place knockout side down on concrete form and nail in place. Wire 12" piece of #4 reinforcing rod on both sides. After concrete pour, knockout can be removed with a screwdriver.

Install in accordance with applicable code.



355N Nut for 355 Series

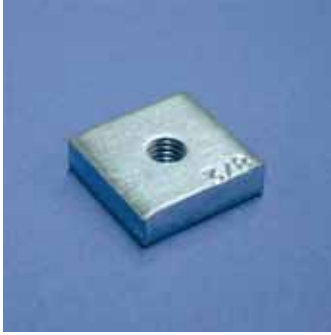

Features

- Insert nut for model 355 Concrete Insert
- Conforms with Federal Specification WW-H-171 (Type 19), Manufacturers Standardization Society ANSI®/MSS-SP-58 (Type 18)

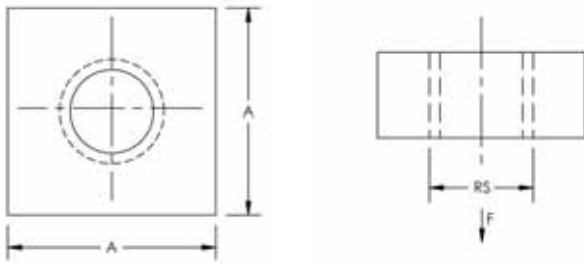

Specifications

Material: Steel

Part Number	Rod Size RS	A	Pipe Size	Static Load F
Finish: Electro-galvanized				
355N0025EG	1/4"	1 1/4"	-	240 lb
355N0037EG	3/8"	1 1/4"	4" Max	610 lb
355N0075EG	3/4"	1 1/4"	8" Max	1,200 lb
355N0087EG	7/8"	1 1/4"	10" Max	1,200 lb
Finish: Plain				
355N0025PL	1/4"	1 1/4"	-	240 lb
355N0037PL	3/8"	1 1/4"	4" Max	610 lb
355N0050PL	1/2"	1 1/4"	8" Max	1,130 lb
355N0062PL	5/8"	1 1/4"	8" Max	1,200 lb
355N0075PL	3/4"	1 1/4"	8" Max	1,200 lb
355N0087PL	7/8"	1 1/4"	10" Max	1,200 lb

Reduced support spacing is required.
Install in accordance with applicable code.

Rigid Bracing System



The CADDY® line of innovative rigid bracing products was designed to provide superior performance and meet the highest seismic load requirements. The products have been designed with the end user in mind and provide contractors with labor-saving features to promote quick and easy installation. The system of products supports lateral and longitudinal bracing and offers a wide range of structural and pipe attachments.

Features:

- Patent-pending lateral braces eliminate need for multiple trips up and down ladders
- Adjustable design can be used with different brace pipe sizes, providing flexibility on the jobsite and reducing contractor inventory
- Snap-off bolt heads help make installation and inspection quick and easy
- Single wrench size installs all products
- For use with brace pipe lengths up to 19' - 8" (6m)
- cULus® Listed
- FM® Approved
- OSHPD® Pre-Approved (OPA-2629-10) to the 2010 California Building Code



Bar Joist Attachment
Page 68-69



Adjustable I-Beam
Attachment
Page 70



I-Beam Attachment
Page 71

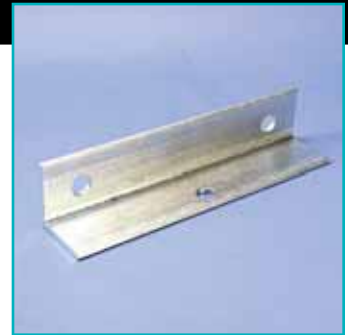

Multi Attachment
Page 72





Universal Structural
Attachment
Page 73



Easy Universal
Sway Brace
Page 74-75



Standard Universal
Sway Brace
Page 76-77



Quick Grip Jr.
Lateral Sway Brace
Page 78-79



Quick Grip Lateral Sway Brace
Page 80-81



Shear Bolt
Page 82



Shear Nut
Page 82

Bar Joist Attachment



Features

- Can be installed on bar joists or I-beams
- Thumb spring retainer allows for ease of positioning
- Snap-off bolt head helps enable easy installation and inspection of seismic sway braces
- No assembly required
- No loose parts
- Meets NFPA®-13 requirements for seismic sway bracing

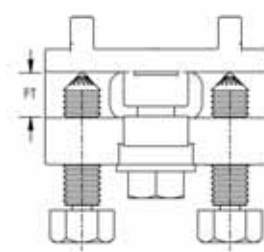
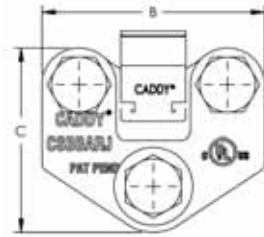
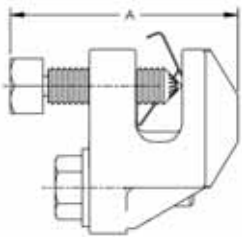

Bar Joist Attachment

Specifications

Material: Steel



Part Number	Flange Thickness FT	A	B	C
Finish: Electro-galvanized				
CSBBARJEG	1/4" – 1/2"	2"	3"	2 1/2"
Finish: Hot-dip galvanized				
CSBBARJHD	1/4" – 1/2"	2"	3"	2 1/2"

UL Loads		
Brace Direction to Structure	Service Pipe Size	Rating
Parallel	1" - 10"	3,000 lb
Perpendicular	1" - 12"	3,740 lb

FM Loads					
Brace Direction to Structure	Service Pipe Size	Horizontal Capacity per Installation Angle from Vertical			
		30° - 44°	45° - 59°	60° - 74°	75° - 90°
Parallel	N/A	1,410 lb	2,110 lb	2,540 lb	2,830 lb
Perpendicular	N/A	1,740 lb	1,710 lb	2,060 lb	2,300 lb

Adjustable I-Beam Attachment



Features

- No loose parts
- No assembly required
- Snap-off bolt head helps enable easy installation and inspection of seismic sway braces
- Meets NFPA®-13 requirements for seismic sway bracing

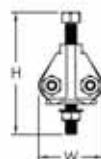
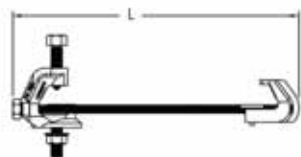
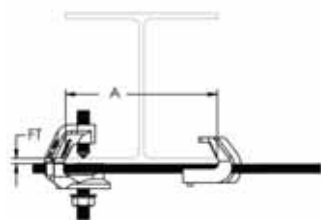

Specifications

Material: Steel



Part Number	Flange Thickness FT	A	Height H	Length L	Width W
Finish: Electro-galvanized					
CSBIB075085EG	1/4" – 3/4"	4" – 8 1/2"	2 1/2"	12"	2 3/4"
CSBIB075145EG	1/4" – 3/4"	8 1/2" – 14 1/2"	2 1/2"	17"	2 3/4"
CSBIB125180EG	3/4" – 1 1/4"	4" – 18"	3 1/2"	21 1/2"	3 1/8"
Finish: Hot-dip galvanized					
CSBIB075085HD	1/4" – 3/4"	4" – 8 1/2"	2 1/2"	12"	2 3/4"
CSBIB075145HD	1/4" – 3/4"	8 1/2" – 14 1/2"	2 1/2"	17"	2 3/4"
CSBIB125180HD	3/4" – 1 1/4"	4" – 18"	3 1/2"	21 1/2"	3 1/8"

UL Loads		
Brace Direction to Structure	Service Pipe Size	Rating
Parallel	1" - 12"	3,740 lb
Perpendicular	1" - 12"	3,740 lb

FM Loads					
Brace Direction to Structure	Service Pipe Size	Horizontal Capacity per Installation Angle from Vertical			
		30° - 44°	45° - 59°	60° - 74°	75° - 90°
Parallel	N/A	1,620 lb	1,710 lb	1,010 lb	1,110 lb
Perpendicular	N/A	1,620 lb	2,300 lb	2,820 lb	3,140 lb



I-Beam Attachment



Features

- Snap-off bolt head helps enable easy installation and inspection of seismic sway braces
- Meets NFPA®-13 requirements for seismic sway bracing

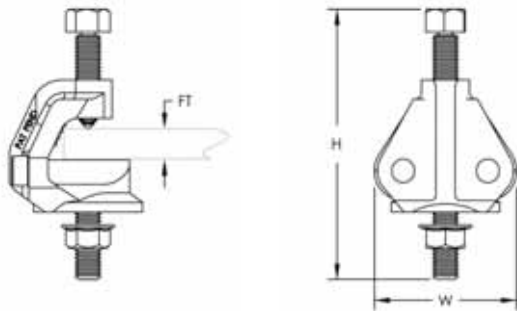

Specifications

Material: Steel
Finish: Electro-galvanized

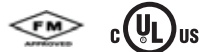

Part Number	Flange Thickness FT	Height H	Width W
CSBBC075EG	1/4" – 3/4"	2 1/2"	2 3/4"

UL Loads		
Brace Direction to Structure	Service Pipe Size	Rating
Parallel	1" - 4"	1,200 lb
Perpendicular	1" - 4"	1,200 lb

FM Loads					
Brace Direction to Structure	Service Pipe Size	Horizontal Capacity per Installation Angle from Vertical			
		30° - 44°	45° - 59°	60° - 74°	75° - 90°
Parallel	N/A	1,190 lb	1,680 lb	1,160 lb	1,280 lb
Perpendicular	N/A	1,620 lb	1,710 lb	1,010 lb	1,110 lb

Multi Attachment



Features

- Disperses load over two anchors
- Minimizes the number of installed braces needed for concrete and wood structures
- Ideal for deck installations
- Use for both lateral and longitudinal sway brace applications
- Meets NFPA®-13 requirements for seismic sway bracing

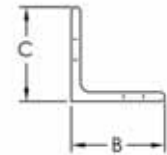
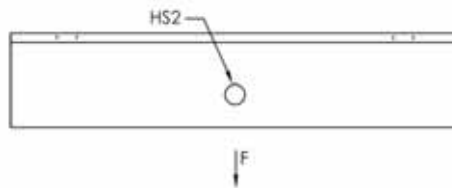
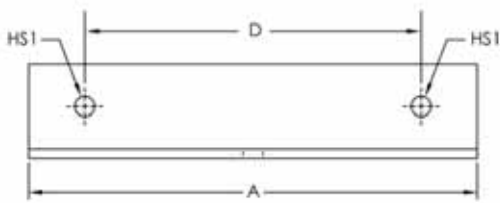

Specifications

Material: Steel
Finish: Electro-galvanized



Part Number	Hole Size 1 HS1	Hole Size 2 HS2	A	B	C	D	UL Listed Load
CSBMA050050EG	9/16"	9/16"	12"	2 1/2"	2 1/2"	9"	3,740 lb
CSBMA050075EG	13/16"	9/16"	12"	2 1/2"	2 1/2"	9"	3,740 lb

Mount to structure using holes indicated in HS1.



Universal Structural Attachment

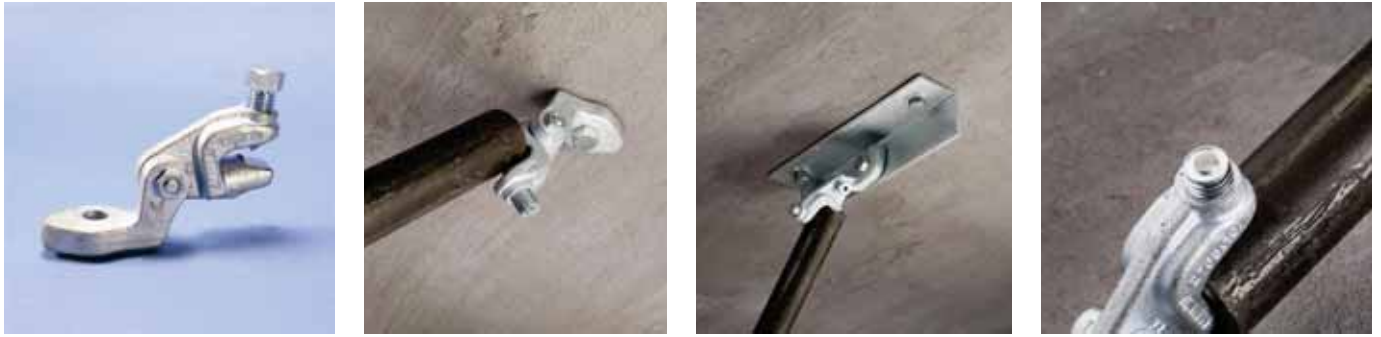

Features

- Universal design allows one product to attach directly to concrete, wood, bar joist or I-beam adapters
- Snap-off bolt head helps enable easy installation and inspection of seismic sway braces
- Use for both lateral and longitudinal sway brace applications
- Works with 1" through 2" brace pipes and 1/4" angle iron braces to reduce inventory
- Center bolt does not require tightening
- Meets NFPA®-13 requirements for seismic sway bracing

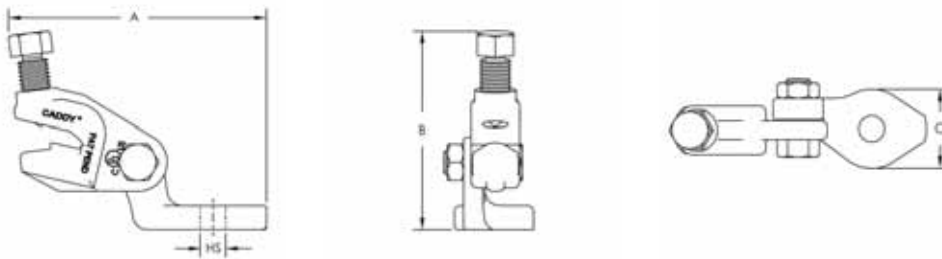

Specifications

Material: Steel

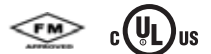

Part Number	Hole Size HS	A	B	C
Finish: Electro-galvanized				
CSBUNIV050EG	9/16"	5 1/4"	4"	1 5/8"
CSBUNIV075EG	13/16"	5 1/4"	4"	1 5/8"
Finish: Hot-dip galvanized				
CSBUNIV050HD	9/16"	5 1/4"	4"	1 5/8"

UL® Loads		
Brace Type	Service Pipe Size	Rating
Pipe	1" - 12"	3,740 lb
1/4" Thick Angle	1" - 8"	2,015 lb

FM® Loads					
Brace Type	Service Pipe Size	Horizontal Capacity per Installation Angle from Vertical			
		30° - 44°	45° - 59°	60° - 74°	75° - 90°
Pipe	N/A	1,620 lb	2,300 lb	2,820 lb	3,140 lb

Easy Universal Sway Brace



Features

- Use for both lateral and longitudinal sway brace applications
- Unique slotted holes provide for easy slip-on installation eliminating loose hardware
- Snap-off bolt head helps enable easy installation and inspection of seismic sway braces
- Works with 1" through 2" brace pipes and 1/4" angle iron braces to reduce inventory
- Meets NFPA®-13 requirements for seismic sway bracing

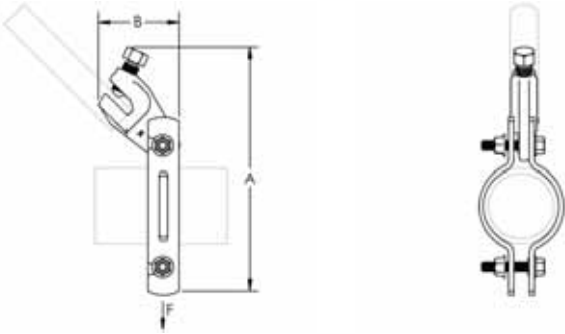

Specifications

Material: Steel

Finish: Electro-galvanized



Part Number	Pipe Size	A	B	Listings Approvals
CSBEZU0100EG	1"	6 7/8"	1"	UL, FM
CSBEZU0125EG	1 1/4"	7 3/8"	1"	UL, FM
CSBEZU0150EG	1 1/2"	7 3/4"	1"	UL, FM
CSBEZU0200EG	2"	8 1/8"	1 3/16"	UL, FM
CSBEZU0250EG	2 1/2"	8 7/8"	1 3/16"	cUL, UL, FM
CSBEZU0300EG	3"	9 3/8"	1 3/16"	cUL, UL, FM
CSBEZU0400EG	4"	10 5/8"	1 1/2"	cUL, UL, FM
CSBEZU0500EG	5"	12 1/8"	1 1/2"	cUL, UL, FM
CSBEZU0600EG	6"	13 5/8"	2"	cUL, UL, FM



Easy Universal Sway Brace

UL® Loads						
Part Number	Lateral			Longitudinal		
	Lightwall Service Pipe	Sch 10 Service Pipe	Sch 40 Service Pipe	Lightwall Service Pipe	Sch 10 Service Pipe	Sch 40 Service Pipe
CSBEZU0100EG	N/A	655 lb	655 lb	N/A	655 lb	655 lb
CSBEZU0125EG	655 lb	655 lb	655 lb	655 lb	655 lb	655 lb
CSBEZU0150EG	655 lb	655 lb	655 lb	655 lb	655 lb	655 lb
CSBEZU0200EG	3,000 lb	3,000 lb	3,000 lb	655 lb	655 lb	655 lb
CSBEZU0250EG	3,000 lb	3,000 lb	3,000 lb	1,265 lb	1,265 lb	1,265 lb
CSBEZU0300EG	3,000 lb	3,000 lb	3,000 lb	1,265 lb	1,265 lb	1,265 lb
CSBEZU0400EG	3,000 lb	3,000 lb	3,000 lb	1,265 lb	1,265 lb	1,265 lb
CSBEZU0500EG	3,000 lb	3,000 lb	3,000 lb	1,600 lb	1,600 lb	1,600 lb
CSBEZU0600EG	3,000 lb	3,000 lb	3,000 lb	1,600 lb	1,600 lb	1,600 lb

FM® Loads (Lightwall, Sch 10 and Sch 40 Service Pipes)								
Part Number	Horizontal Capacity per Installation Angle from Vertical							
	Lateral				Longitudinal			
	30° - 44°	45° - 59°	60° - 74°	75° - 90°	30° - 44°	45° - 59°	60° - 74°	75° - 90°
CSBEZU0100EG	860 lb	1,220 lb	1,500 lb	1,670 lb	390 lb	550 lb	670 lb	750 lb
CSBEZU0125EG	860 lb	1,220 lb	1,500 lb	1,670 lb	390 lb	550 lb	670 lb	750 lb
CSBEZU0150EG	860 lb	1,220 lb	1,500 lb	1,670 lb	390 lb	550 lb	670 lb	750 lb
CSBEZU0200EG	1,530 lb	2,160 lb	2,650 lb	2,960 lb	520 lb	690 lb	830 lb	930 lb
CSBEZU0250EG	1,530 lb	2,160 lb	2,650 lb	2,960 lb	520 lb	690 lb	830 lb	930 lb
CSBEZU0300EG	1,530 lb	2,160 lb	2,650 lb	2,960 lb	520 lb	690 lb	830 lb	930 lb
CSBEZU0400EG	1,570 lb	2,220 lb	2,720 lb	3,030 lb	630 lb	900 lb	1,100 lb	1,230 lb
CSBEZU0500EG	1,570 lb	2,220 lb	2,720 lb	3,030 lb	630 lb	900 lb	1,100 lb	1,230 lb
CSBEZU0600EG	1,980 lb	2,810 lb	3,440 lb	3,840 lb	730 lb	1,000 lb	1,230 lb	1,370 lb

Standard Universal Sway Brace

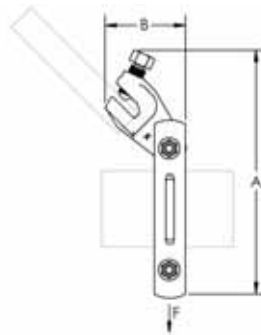

Features

- Use for both lateral and longitudinal sway brace applications
- Snap-off bolt head helps enable easy installation and inspection of seismic sway braces
- Works with 1" through 2" brace pipes and 1/4" angle iron braces to reduce inventory
- Slotted design grabs service pipe for added gripping strength
- Meets NFPA®-13 requirements for seismic sway bracing

Specifications

Material: Steel



Part Number	Pipe Size	A	B	Listings Approvals
Finish: Electro-galvanized				
CSBSTU0100EG	1"	6 7/8"	1"	UL, FM
CSBSTU0125EG	1 1/4"	7 3/8"	1"	UL, FM
CSBSTU0150EG	1 1/2"	7 3/4"	1"	UL, FM
CSBSTU0200EG	2"	8 1/8"	1 3/16"	UL, FM
CSBSTU0250EG	2 1/2"	8 7/8"	1 3/16"	cUL, UL, FM
CSBSTU0300EG	3"	9 3/8"	1 3/16"	cUL, UL, FM
CSBSTU0400EG	4"	10 5/8"	1 1/2"	cUL, UL, FM
CSBSTU0500EG	5"	12 1/8"	1 1/2"	cUL, UL, FM
CSBSTU0600EG	6"	13 5/8"	2"	cUL, UL, FM
CSBSTU0800EG	8"	15 3/4"	2"	cUL, UL, FM
CSBSTU1000EG	10"	18"	2"	cUL, UL, FM
Finish: Hot-dip galvanized				
CSBSTU0100HD	1"	6 7/8"	1"	UL, FM
CSBSTU0125HD	1 1/4"	7 3/8"	1"	UL, FM
CSBSTU0150HD	1 1/2"	7 3/4"	1"	UL, FM
CSBSTU0200HD	2"	8 1/8"	1 3/16"	UL, FM
CSBSTU0250HD	2 1/2"	8 7/8"	1 3/16"	cUL, UL, FM
CSBSTU0300HD	3"	9 3/8"	1 3/16"	cUL, UL, FM
CSBSTU0400HD	4"	10 5/8"	1 1/2"	cUL, UL, FM
CSBSTU0500HD	5"	12 1/8"	1 1/2"	cUL, UL, FM
CSBSTU0600HD	6"	13 5/8"	2"	cUL, UL, FM
CSBSTU0800HD	8"	15 3/4"	2"	cUL, UL, FM
CSBSTU1000HD	10"	18"	2"	cUL, UL, FM



Standard Universal Sway Brace

UL Loads						
Part Number	Lateral			Longitudinal		
	Lightwall Service Pipe	Sch 10 Service Pipe	Sch 40 Service Pipe	Lightwall Service Pipe	Sch 10 Service Pipe	Sch 40 Service Pipe
CSBSTU0100xx	N/A	655 lb	655 lb	N/A	655 lb	655 lb
CSBSTU0125xx	655 lb	655 lb	655 lb	655 lb	655 lb	655 lb
CSBSTU0150xx	655 lb	655 lb	655 lb	655 lb	655 lb	655 lb
CSBSTU0200xx	3,000 lb	3,000 lb	3,000 lb	655 lb	655 lb	655 lb
CSBSTU0250xx	3,000 lb	3,000 lb	3,000 lb	2,015 lb	2,015 lb	2,015 lb
CSBSTU0300xx	3,000 lb	3,000 lb	3,000 lb	2,015 lb	2,015 lb	2,015 lb
CSBSTU0400xx	3,000 lb	3,000 lb	3,000 lb	2,015 lb	2,015 lb	2,015 lb
CSBSTU0500xx	3,000 lb	3,000 lb	3,000 lb	N/A	2,015 lb	2,015 lb
CSBSTU0600xx	3,000 lb	3,000 lb	3,000 lb	2,015 lb	2,015 lb	2,015 lb
CSBSTU0800xx	N/A	3,000 lb	3,000 lb	N/A	2,015 lb	2,015 lb
CSBSTU1000xx	N/A	3,000 lb	3,000 lb	N/A	3,000 lb	3,000 lb

FM Loads (Lightwall, Sch 10 and Sch 40 Service Pipes)								
Part Number	Horizontal Capacity per Installation Angle from Vertical							
	Lateral				Longitudinal			
	30° - 44°	45° - 59°	60° - 74°	75° - 90°	30° - 44°	45° - 59°	60° - 74°	75° - 90°
CSBSTU0100xx	860 lb	1,220 lb	1,500 lb	1,670 lb	970 lb	720 lb	860 lb	960 lb
CSBSTU0125xx	860 lb	1,220 lb	1,500 lb	1,670 lb	970 lb	720 lb	860 lb	960 lb
CSBSTU0150xx	860 lb	1,220 lb	1,500 lb	1,670 lb	970 lb	720 lb	860 lb	960 lb
CSBSTU0200xx	1,530 lb	2,160 lb	2,650 lb	2,960 lb	870 lb	690 lb	830 lb	930 lb
CSBSTU0250xx	1,530 lb	2,160 lb	2,650 lb	2,960 lb	870 lb	690 lb	830 lb	930 lb
CSBSTU0300xx	1,530 lb	2,160 lb	2,650 lb	2,960 lb	870 lb	690 lb	830 lb	930 lb
CSBSTU0400xx	1,570 lb	2,220 lb	2,720 lb	3,030 lb	1,550 lb	1,390 lb	1,680 lb	1,870 lb
CSBSTU0500xx	1,570 lb	2,220 lb	2,720 lb	3,030 lb	1,550 lb	1,390 lb	1,680 lb	1,870 lb
CSBSTU0600xx	1,980 lb	2,810 lb	3,440 lb	3,840 lb	1,470 lb	1,170 lb	1,410 lb	1,570 lb

FM Loads (0.188" wall and Sch 40 Service Pipes)								
Part Number	Horizontal Capacity per Installation Angle from Vertical							
	Lateral				Longitudinal			
	30° - 44°	45° - 59°	60° - 74°	75° - 90°	30° - 44°	45° - 59°	60° - 74°	75° - 90°
CSBSTU0800xx	2,040 lb	2,890 lb	3,540 lb	3,950 lb	1,200 lb	1,700 lb	2,090 lb	2,330 lb
CSBSTU1000xx	2,040 lb	2,890 lb	3,540 lb	3,950 lb	1,200 lb	1,700 lb	2,090 lb	2,330 lb

Quick Grip Jr. Lateral Sway Brace



Features

- Easy two-step installation eliminates extra trips between structure and service pipe
- Works with 1" and 1 1/4" (25 mm and 32 mm) brace pipes to reduce inventory
- Snap-off bolt head helps enable easy installation and inspection of seismic sway braces
- Meets NFPA®-13 requirements for seismic sway bracing

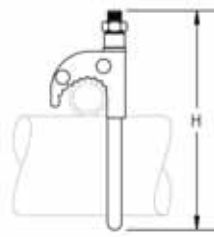
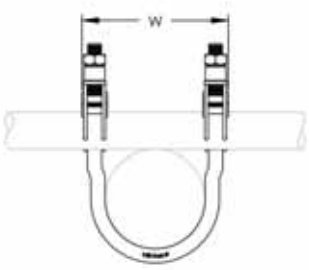

Specifications

Material: Steel
Finish: Electro-galvanized



Part Number	Pipe Size	Height H	Width W
CSBQIKCL0100EG	1"	5 1/8"	2 5/8"
CSBQIKCL0125EG	1 1/4"	5 3/8"	3"
CSBQIKCL0150EG	1 1/2"	5 5/8"	3 1/4"
CSBQIKCL0200EG	2"	6 3/8"	3 5/8"



Quick Grip Jr. Lateral Sway Brace

UL Loads			
Part Number	Service Pipe Schedule	Lateral	
		1" Brace Pipe	1 1/4" Brace Pipe
CSBQIKCL0100EG	Lightwall	N/A	N/A
	10	655 lb	655 lb
	40	655 lb	655 lb
CSBQIKCL0125EG	Lightwall	655 lb	540 lb
	10	655 lb	540 lb
	40	655 lb	540 lb
CSBQIKCL0150EG	Lightwall	750 lb	655 lb
	10	750 lb	655 lb
	40	750 lb	655 lb
CSBQIKCL0200EG	Lightwall	750 lb	540 lb
	10	750 lb	540 lb
	40	750 lb	540 lb

FM Loads					
Part Number	Service Pipe Schedule	Lateral			
		Horizontal Capacity per Installation Angle from Vertical			
		30° - 44°	45° - 59°	60° - 74°	75° - 90°
CSBQIKCL0100EG	Lightwall	290 lb	410 lb	495 lb	550 lb
	10	150 lb	210 lb	280 lb	315 lb
	40	475 lb	665 lb	825 lb	925 lb
CSBQIKCL0125EG	Lightwall	290 lb	410 lb	495 lb	550 lb
	10	150 lb	210 lb	280 lb	315 lb
	40	475 lb	665 lb	825 lb	925 lb
CSBQIKCL0150EG	Lightwall	290 lb	410 lb	495 lb	550 lb
	10	150 lb	210 lb	280 lb	315 lb
	40	475 lb	665 lb	825 lb	925 lb
CSBQIKCL0200EG	Lightwall	390 lb	550 lb	670 lb	750 lb
	10	350 lb	500 lb	620 lb	690 lb
	40	490 lb	690 lb	850 lb	950 lb

Quick Grip Lateral Sway Brace



The Quick Grip Lateral Brace, part of the CADDY® line of fire sprinkler bracing systems from ERICO, is designed to help simplify installations when bracing service pipe for seismic or other catastrophic events. It features an innovative design for quick attachment of brace pipe to service pipe saving time and money.

Features

- Easy two-step installation eliminates extra trips between structure and service pipe
- Works with 1" and 1 1/4" (25 mm and 32 mm) brace pipes to reduce inventory
- Yellow tips provide a visual indicator that the bolts have been properly torqued
- Easy installation with an impact wrench from the bottom side of the clamp
- Meets NFPA®-13 requirements for seismic sway bracing

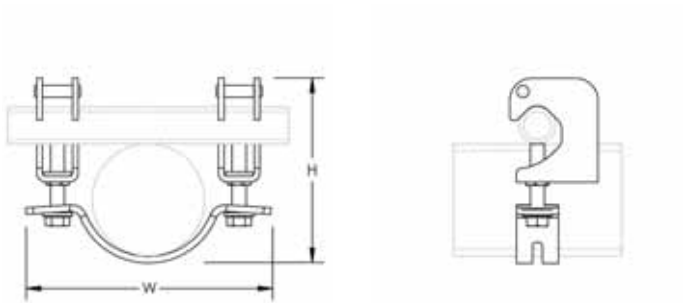

Specifications

Material: Steel

Finish: Electro-galvanized



Part Number	Pipe Size	Height H	Width W
CSBQG0250EG	2 1/2"	5 7/16" – 5 7/8"	6 3/4"
CSBQG0300EG	3"	6 1/8" – 6 1/2"	7 1/2"
CSBQG0400EG	4"	7 1/8" – 7 1/2"	8 3/4"
CSBQG0500EG	5"	8 1/8" – 8 9/16"	10 1/4"
CSBQG0600EG	6"	9 1/4" – 9 5/8"	11 3/4"
CSBQG0800EG	8"	11 3/8" – 11 13/16"	13 7/8"



Quick Grip Lateral Sway Brace

UL Loads				
Part Number	Service Pipe Size	Service Pipe Schedule	Lateral	
			1" Brace Pipe	1 1/4" Brace Pipe
CSBQG0250EG	2 1/2"	Lightwall	2,015 lb	2,015 lb
		10	2,015 lb	2,015 lb
		40	2,015 lb	2,015 lb
CSBQG0300EG	3"	Lightwall	2,015 lb	2,015 lb
		10	2,015 lb	2,015 lb
		40	2,015 lb	2,015 lb
CSBQG0400EG	4"	Lightwall	2,015 lb	2,015 lb
		10	2,015 lb	2,015 lb
		40	2,015 lb	2,015 lb
CSBQG0500EG	5"	10	2,015 lb	2,015 lb
		40	2,015 lb	2,015 lb
CSBQG0600EG	6"	Lightwall	2,015 lb	2,015 lb
		10	2,015 lb	2,015 lb
		40	2,015 lb	2,015 lb
CSBQG0800EG	8"	10	2,015 lb	2,015 lb
		40	2,015 lb	2,015 lb

FM Loads						
Part Number	Service Pipe Size	Service Pipe Schedule	Lateral			
			Horizontal Capacity per Installation Angle from Vertical			
			30° - 44°	45° - 59°	60° - 74°	75° - 90°
CSBQG0250EG	2 1/2"	Lightwall	1,410 lb	2,000 lb	2,450 lb	2,740 lb
		10	1,410 lb	2,000 lb	2,450 lb	2,740 lb
		40	1,410 lb	2,000 lb	2,450 lb	2,740 lb
CSBQG0300EG	3"	Lightwall	1,190 lb	1,680 lb	2,060 lb	2,300 lb
		10	1,190 lb	1,680 lb	2,060 lb	2,300 lb
		40	1,190 lb	1,680 lb	2,060 lb	2,300 lb
CSBQG0400EG	4"	Lightwall	1,190 lb	1,680 lb	2,060 lb	2,300 lb
		10	1,190 lb	1,680 lb	2,060 lb	2,300 lb
		40	1,190 lb	1,680 lb	2,060 lb	2,300 lb
CSBQG0500EG	5"	Lightwall	870 lb	1,230 lb	1,510 lb	1,690 lb
		10	870 lb	1,230 lb	1,510 lb	1,690 lb
		40	970 lb	1,370 lb	1,680 lb	1,870 lb
CSBQG0600EG	6"	Lightwall	870 lb	1,230 lb	1,510 lb	1,690 lb
		10	870 lb	1,230 lb	1,510 lb	1,690 lb
		40	970 lb	1,370 lb	1,680 lb	1,870 lb
CSBQG0800EG	8"	0.188" (Wall Thickness)	790 lb	1,110 lb	1,360 lb	1,520 lb
		40	790 lb	1,110 lb	1,360 lb	1,520 lb

Shear Bolt



Specifications

Material: Steel

Finish: Electro-galvanized

Part Number	Description
CSBBARJSB50EG	Shear Bolt for Bar Joist Attachment
CSBIBSB50EG	Shear Bolt for I-Beam Attachment
CSBUNIVSB62EG	Shear Bolt for Easy/Standard Universal Sway Brace and Universal Structural Attachment

Shear Nut

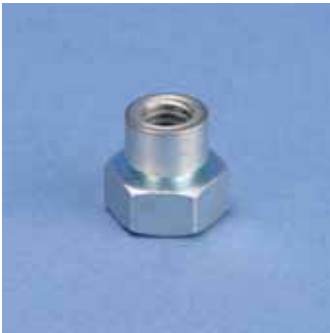

Specifications

Material: Steel

Finish: Electro-galvanized

Part Number	Description
CSBIBSN37EG	Shear Nut for Adjustable I-Beam Attachment
CSBQIKCLSN37EG	Shear Nut for Quick Grip Jr. Lateral Sway Brace, 1" - 2" Pipe



Now There's a Faster, Easier Way to Restrain Branch Lines in a Fire Sprinkler System



The New CADDY® Branch Line Restraint System

- Complete restraint system includes structure and pipe attachments
- Works with 3/8" and 1/2" rod
- Quick and easy installation
- Meets NFPA® 13
- cULus Listed and FM® Approved
- OSHPD pre-approved



Wide Range of Structural Attachments:



Pipe Attachment:

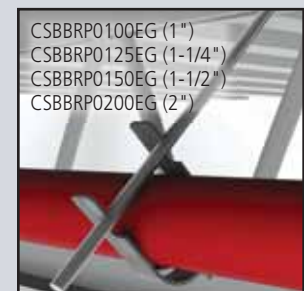

Another Innovative Hanging & Bracing Fire Protection Solution From ERICO.



FM is a registered certification mark of FM Approvals LLC, LTD.
NFPA is a registered trademark of the National Fire Protection Association.

**Save time on your next installation
with the Branch Line Restraint System.
See page 93 for full details.**

ERICO®

Cable Bracing System

CADDY® cable bracing is an ideal alternative to rigid bracing for fire sprinkler systems when brace lengths greater than 19'- 8" (6m) are required or when confined/crowded spaces make rigid systems difficult to install. The system includes pre-stretched steel cable, attachment fittings, crimping sleeves and related tools. The system can also be used to brace electrical, mechanical and plumbing systems.

Features:

- Color-coated cable conforms to NFPA® 13 requirements and makes it highly visible and easier to identify cable sizes
- UL® Listed
- OSHPD® Pre-Approved (OPA-0619)
- Made in the USA



Cable Spool
Page 86



Crimping Sleeve
Page 86



Stake Eye Kit
Page 87



Loop Attachment Clip
Page 88





No Pry Clip
Page 88



Universal Restraint Clip
Page 89



Universal Restraint Clip,
Retrofit
Page 90



Cable Cutter
Page 91



Manual Swaging Tool
Page 91



Multi-Size Manual
Swaging Tool
Page 92



Power Swaging Tool
Page 92



Die Set for Power
Swaging Tool
Page 92

Cable Spool



Features

- Cut to length as needed
- Pre-stretched restraint cable

Specifications

Material: Steel

Finish: Pre-galvanized, Painted



Part Number	Brace Size	Diameter	Cable Length	UL Listed Load	Color
CSB12CBL	#12	3/32"	250'	613 lb	Red
CSB18CBL	#18	1/8"	250'	1,133 lb	White
CSB36CBL	#36	3/16"	250'	2,800 lb	Blue
CSB48CBL	#48	1/4"	250'	4,667 lb	Yellow

Cable is powder coated.

Crimping Sleeve



Features

- Creates secure loop ends
- Crimp with swaging tools

Specifications

Material: Copper

Finish: Electro-galvanized



Part Number	Brace Size
CSB12SLVB	#12
CSB18SLVB	#18
CSB36SLVB	#36
CSB48SLVB	#48

Two side-by-side crimps required on #12 and #18 cable. Three side-by-side crimps required on #36 and #48 cable. Check crimp with gauge (not included).



Stake Eye Kit



Features

- Attaches to steel, wood or concrete structures
- Two-way bracing kit with crimp sleeves and stake eyes
- Swaged-on stake eye, pre-bent to 45 degrees

Specifications

Material: Steel



Part Number	Brace Size	Hole Size	Brace Length	Cable Length	UL Listed Load	Color
CSB12BD38L7	#12	7/16"	7'	11'	600 lb	Red
CSB12BD38L10	#12	7/16"	10'	14'	600 lb	Red
CSB12BD50L7	#12	9/16"	7'	11'	600 lb	Red
CSB12BD50L10	#12	9/16"	10'	14'	600 lb	Red
CSB18BD38L7	#18	7/16"	7'	11'	1,100 lb	White
CSB18BD38L10	#18	7/16"	10'	14'	1,100 lb	White
CSB18BD50L7	#18	9/16"	7'	11'	1,100 lb	White
CSB18BD50L10	#18	9/16"	10'	14'	1,100 lb	White
CSB36BD38L7	#36	7/16"	7'	11'	2,800 lb	Blue
CSB36BD38L10	#36	7/16"	10'	14'	2,800 lb	Blue
CSB36BD50L7	#36	9/16"	7'	11'	2,800 lb	Blue
CSB36BD50L10	#36	9/16"	10'	14'	2,800 lb	Blue

Kits contain copper sleeves.

Loop Attachment Kit



Features

- Two-way bracing kit with crimp sleeves
- Wraps around structural steel members

Specifications

Material: Steel



Part Number	Brace Size	Brace Length	Cable Length	UL Listed Load	Color
CSB12B00L7	#12	7'	11'	600 lb	Red
CSB12B00L10	#12	10'	14'	600 lb	Red
CSB18B00L7	#18	7'	11'	1,100 lb	White
CSB18B00L10	#18	10'	14'	1,100 lb	White

Stake eyes not included.

CABLE BRACING SYSTEM

No Pry Clip



Features

- Eliminates prying effect on fasteners and anchors

Specifications

Material: Steel

Finish: Electro-galvanized



Part Number	Brace Size	Hole Size	UL Listed Load
CSBNPC12	#12, #18, #36	9/16"	2,800 lb



Universal Restraint Clip



Features

- Attaches cable brace to structure

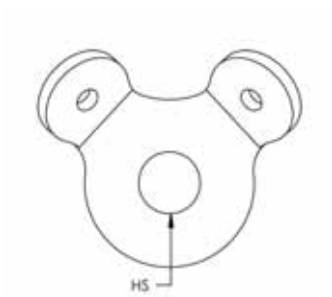

Specifications

Material: Steel
Finish: Electro-galvanized



Part Number	Brace Size	Hole Size HS	UL Listed Load
CSBURC38	#12, #18, #36	7/16"	1,600 lb
CSBURC12	#12, #18, #36	9/16"	1,600 lb
CSBURC58	#12, #18, #36	11/16"	1,600 lb
CSBURC4812	#48	9/16"	4,600 lb
CSBURC4858	#48	11/16"	4,600 lb
CSBURC4834	#48	13/16"	4,600 lb

Mount to the structure using the center hole. Loop cable through the holes in the bent tabs and crimp in place.
For #48 cable, use two clips stacked together.

Universal Restraint Clip, Retrofit

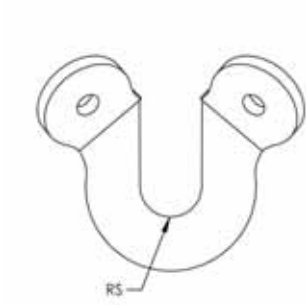

Features

- Slotted design ideal for attaching to existing threaded rod on trapezes

Specifications

Material: Steel

Finish: Electro-galvanized

Part Number	Brace Size	Rod Size RS
CSBURCR38	#12, #18	3/8"
CSBURCR12	#12, #18	1/2"
CSBURCR58	#12, #18	5/8"

One fastener required for #12 cable. Two stacked fasteners required for #18 cable.



Cable Cutter



Features

- Designed to reduce cable fraying

Specifications

Material: Steel

Part Number	Brace Size
CSBC9	#12, #18, #36, #48

Manual Swaging Tool



Specifications

Material: Steel



Part Number	Brace Size	Listings
CSB12SBHS	#12	--
CSB48	#48	UL

Multi-Size Manual Swaging Tool



Specifications

Material: Steel

Part Number	Brace Size
CSB3346SB	#12, #18, #36

Power Swaging Tool



Features

- Additional die sets available

Specifications

Material: Steel

Part Number	Brace Size	Voltage
CSBHS02	#12, #18, #36, #48	110 V - 60 Hz

Die Set for Power Swaging Tool



Specifications

Material: Steel

Part Number	Brace Size
CSBDI23	#12
CSBDI24	#18
CSBDI26	#36
CSBDI28	#48



Branch Line Restraint System



Traditional methods for installing branch line restraints in fire sprinkler systems are cumbersome and time-consuming. Contractors often cut (and re-cut) threaded rod to precise measurements to restrain the sprinkler pipe with a loop hanger and surge restraint. Traditional methods also commonly require five or more parts per restraint.

To avoid these labor-intensive methods, ERICO has streamlined the process and developed the Branch Line Restraint System, part of the CADDY® line of hanging and bracing solutions for the fire protection market. Ideal for restraining 1" (25 mm) through 2" (50 mm) branch lines, this innovative system is significantly faster and easier to install than current methods. It attaches directly to steel bar joists, I-beams or purlins, as well as concrete and wood structures. The hardware is installed with only one tool, a 5/16" (8 mm) socket drill driver, which provides significant labor savings and convenience. It features a simple, two-step installation process, allowing a time savings of up to 80% compared to other methods.

Unlike most solutions that only accept 3/8" (M10) threaded rod, the versatile Branch Line Restraint System features a swivel attachment that can be rotated to accept 3/8" or 1/2" (M10 or M12) threaded rod. This allows greater restraint distances from the pipe to structure with 1/2" (M12) threaded rod.

The system meets the requirements of NFPA® 13, making it ideal for new construction applications. The total system is cULus® Listed and FM® Approved, and has been pre-approved by the state of California (OSHPD OPA-2629-10).



Branch Line Restraint
Pipe Attachment
Page 94



Branch Line Restraint Structure
Attachment to Steel
Page 95



Branch Line Restraint Structure
Attachment to Wood/Concrete
Page 96



Branch Line Restraint Structure
Attachment to Threaded Hole
Page 97

Branch Line Restraint Pipe Attachment



Features

- Accepts 3/8" or 1/2" (M10 or M12) threaded rod
- Quick grip clamp simplifies measuring and cutting of threaded rod
- Works with rough-cut threaded rod and eliminates pipe-side deburring
- Can be installed with threaded rod above or below the service pipe
- Shear-off head helps ensure correct torque and simplifies inspection

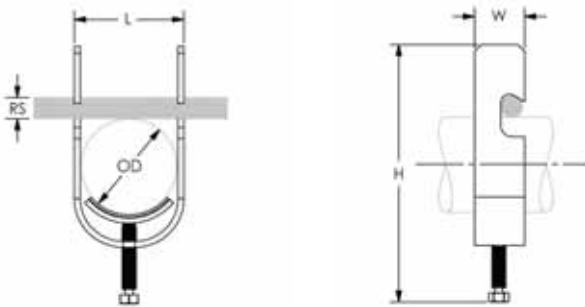

Specifications

Material: Steel
Finish: Electro-galvanized



Part Number	Pipe Size	Outer Diameter OD	Rod Size RS	Height H	Length L	Width W
CSBBRP0100EG	1"	1.32"	3/8", 1/2"	6.67"	1.63"	0.88"
CSBBRP0125EG	1 1/4"	1.66"	3/8", 1/2"	7.56"	1.97"	0.88"
CSBBRP0150EG	1 1/2"	1.90"	3/8", 1/2"	8.20"	2.21"	0.88"
CSBBRP0200EG	2"	2.38"	3/8", 1/2"	9.45"	2.69"	0.88"



Branch Line Restraint Structure Attachment to Steel



Features

- Swivel connector accepts 3/8" or 1/2" (M10 or M12) threaded rod
- Attaches to steel members with self-drilling/tapping screw

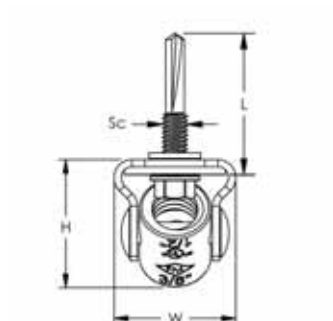
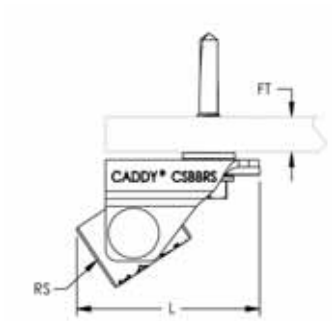

Specifications

Material: Steel

Finish: Electro-galvanized



Part Number	Rod Size RS	Flange Thickness FT	Height H	Length L	Width W	Screw Diameter Sc	Screw Length L
CSBBS1EG	3/8", 1/2"	0.105" – 1/2"	1.11"	1.59"	1.06"	#12	1 1/4"

Branch line structural attachments are for restraint only and not for the hanging of fire sprinkler piping.

Branch Line Restraint Structure Attachment to Wood/Concrete



Features

- Swivel connector accepts 3/8" or 1/2" (M10 or M12) threaded rod
- Attaches to wood or concrete structures

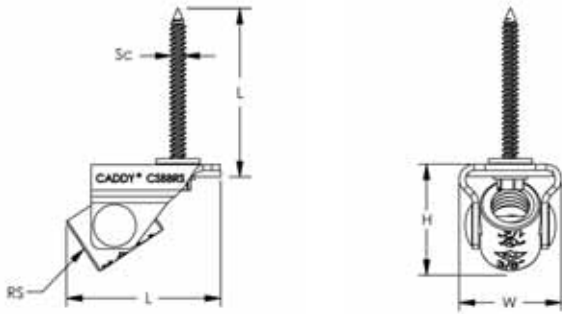

Specifications

Material: Steel
Finish: Electro-galvanized



Part Number	Rod Size RS	Height H	Length L	Width W	Screw Diameter Sc	Screw Length L	Drill Bit Size
CSBRS2EG	3/8", 1/2"	1.11"	1.59"	1.06"	1/4"	1 3/4"	3/16"

Branch line structural attachments are for restraint only and not for the hanging of fire sprinkler piping.



Branch Line Restraint Structure Attachment to Threaded Hole

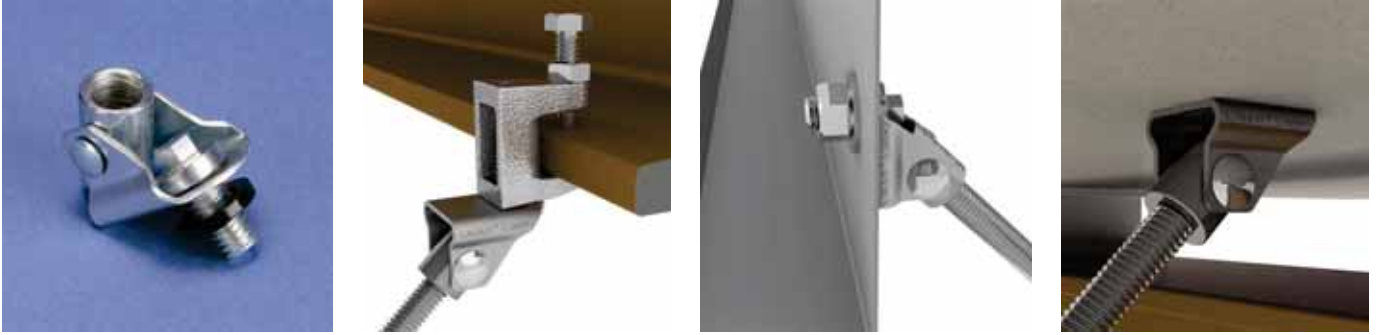

Features

- Swivel connector accepts 3/8" or 1/2" (M10 or M12) threaded rod
- Attaches to concrete anchors or structural attachments with female threads

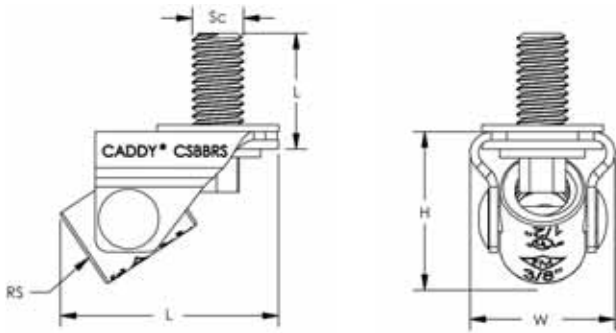

Specifications

Material: Steel

Finish: Electro-galvanized



Part Number	Rod Size RS	Height H	Length L	Width W	Screw Diameter Sc	Screw Length L
CSBBRS3EG	3/8", 1/2"	1.11"	1.59"	1.06"	3/8"	3/4"

Branch line structural attachments are for restraint only and not for the hanging of fire sprinkler piping.

Bracing Accessories



Strut Seismic Hinge
Page 99



Pipe Rod Stiffener
Page 100



Strut Rod Stiffener
Page 101



Strut Seismic Hinge



Features

- Complete hinge assembly
- Ideal for attaching sway bracing to MEP system supports
- Attaches to strut trapezes and to structure

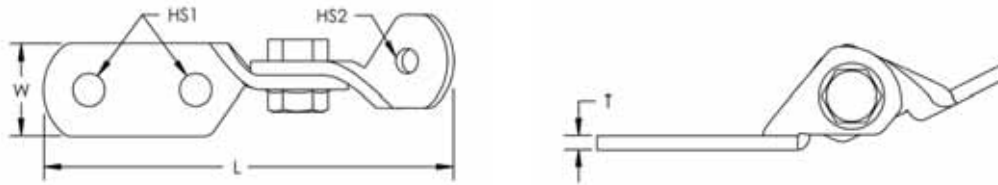

Specifications

Material: Steel

Finish: Electro-galvanized

Part Number	Hole Size 1 HS1	Hole Size 2 HS2	Length L	Width W	Thickness T
CSBSH00375EG	9/16"	7/16"	7 1/16"	1 5/8"	1/4"
CSBSH00500EG	9/16"	9/16"	7 1/16"	1 5/8"	1/4"
CSBSH00625EG	9/16"	11/16"	7 1/16"	1 5/8"	1/4"
CSBSH00750EG	9/16"	13/16"	7 1/16"	1 5/8"	1/4"

Pipe Rod Stiffener



Features

- For use with Schedule 40 or Schedule 10 pipe
- Secures pipe to threaded rod for stiffening

Specifications

Material: Steel

Finish: Electro-galvanized

Part Number	Brace Pipe Size	Rod Size
CSBRS1	1"	3/8", 1/2", 5/8"



Strut Rod Stiffener



Features

- Secures strut channel to threaded rod for stiffening

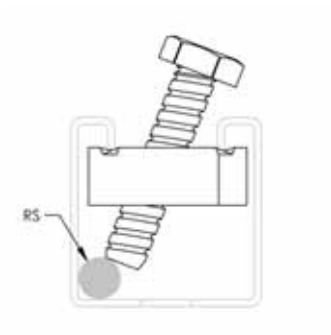

Specifications

Material: Steel
 Finish: Electro-galvanized

Part Number	Strut Type	Rod Size RS
CSBRS37EG	A	3/8", 1/2", 5/8", 3/4"

BRACING ACCESSORIES

Hardware

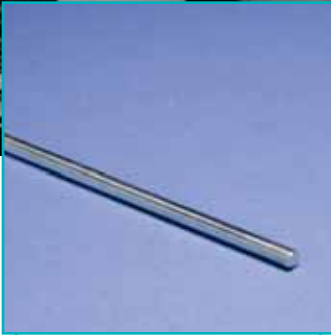

Threaded Rod
Page 103



150M Standard U-Bolt
Page 104-405

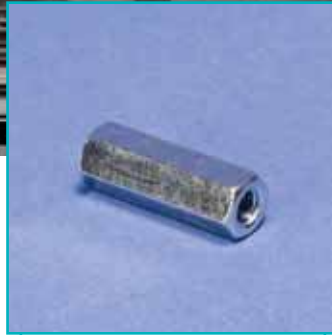

EM-HEX Rod Coupler
Page 106



25R Hex Rod Reducer
Page 106



42 Hex Head Lag Screw
Page 107



43 Wood Drive Screw
Page 108



80 Tie Bolt
Page 109



Threaded Rod

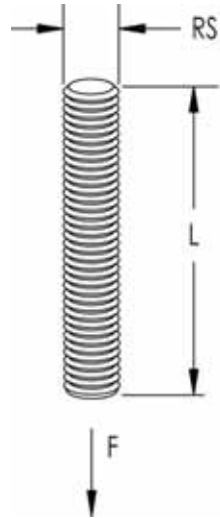
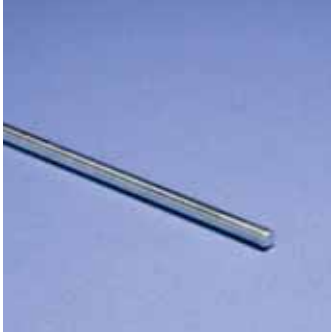

Features

- Attaches hangers to structural attachments without threading the rod

Specifications

Material: Steel

Tensile Strength: 58,000 psi

Yield Strength: 36,000 psi

Part Number	Rod Size RS	Length L	Static Load F
Finish: Electro-galvanized			
0502506EG	1/4"	6'	240 lb
0502510EG	1/4"	10'	240 lb
0502512EG	1/4"	12'	240 lb
0503706EG	3/8"	6'	610 lb
0503710EG	3/8"	10'	610 lb
0503712EG	3/8"	12'	610 lb
0505006EG	1/2"	6'	1,130 lb
0505010EG	1/2"	10'	1,130 lb
0505012EG	1/2"	12'	1,130 lb
0506206EG	5/8"	6'	1,810 lb
0506210EG	5/8"	10'	1,810 lb
0506212EG	5/8"	12'	1,810 lb
0507506EG	3/4"	6'	2,710 lb
0507510EG	3/4"	10'	2,710 lb
0507512EG	3/4"	12'	2,710 lb
0508706EG	7/8"	6'	3,770 lb
0508710EG	7/8"	10'	3,770 lb
0508712EG	7/8"	12'	3,770 lb
0501010EG	1"	10'	4,770 lb

Load based on Max. 650 degrees F.

Part Number	Rod Size RS	Length L	Static Load F
Finish: Plain			
0502506PL	1/4"	6'	240 lb
0502510PL	1/4"	10'	240 lb
0502512PL	1/4"	12'	240 lb
0503706PL	3/8"	6'	610 lb
0503710PL	3/8"	10'	610 lb
0503712PL	3/8"	12'	610 lb
0505006PL	1/2"	6'	1,130 lb
0505010PL	1/2"	10'	1,130 lb
0505012PL	1/2"	12'	1,130 lb
0506206PL	5/8"	6'	1,810 lb
0506210PL	5/8"	10'	1,810 lb
0506212PL	5/8"	12'	1,810 lb
0507506PL	3/4"	6'	2,710 lb
0507510PL	3/4"	10'	2,710 lb
0507512PL	3/4"	12'	2,710 lb
0508706PL	7/8"	6'	3,770 lb
0508710PL	7/8"	10'	3,770 lb
0508712PL	7/8"	12'	3,770 lb
0501010PL	1"	10'	4,770 lb

Load based on Max. 650 degrees F.

150M Standard U-Bolt

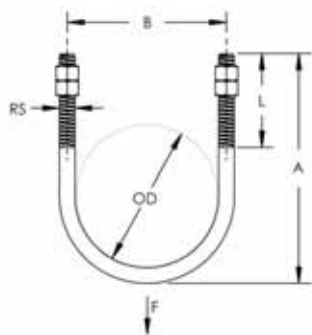

Features

- Complete with 4 nuts

Specifications

Part Number	Pipe Size	Outer Diameter OD	Rod Size RS	Screw Length L	A	B	Static Load F
Material: Steel – Finish: Electro-galvanized							
150M0050EG	1/2"	0.840"	1/4"	2 3/8"	3 1/2"	1 1/16"	435 lb
150M0075EG	3/4"	1.050"	1/4"	2 3/8"	3 9/16"	1 5/16"	435 lb
150M0100EG	1"	1.315"	1/4"	2 3/8"	3 11/16"	1 9/16"	435 lb
150M0125EG	1 1/4"	1.660"	3/8"	2 3/8"	4 1/8"	2 1/16"	1,090 lb
150M0150EG	1 1/2"	1.900"	3/8"	2 1/2"	4 5/16"	2 1/4"	1,090 lb
150M0200EG	2"	2 3/8"	3/8"	2 1/2"	4 13/16"	2 3/4"	1,090 lb
150M0250EG	2 1/2"	2 7/8"	1/2"	3"	5 3/4"	3 3/8"	2,020 lb
150M0300EG	3"	3 1/2"	1/2"	3"	6 5/16"	4"	2,020 lb
150M0400EG	4"	4 1/2"	1/2"	3"	7 5/16"	5"	2,020 lb
150M0500EG	5"	5 9/16"	1/2"	3"	8 5/16"	6 1/16"	2,020 lb
150M0600EG	6"	6 5/8"	5/8"	3 3/4"	10 1/8"	7 1/4"	3,230 lb
150M0800EG	8"	8 5/8"	5/8"	3 3/4"	12 1/8"	9 1/4"	3,230 lb
150M1000EG	10"	10 3/4"	3/4"	4"	14 9/16"	11 1/2"	4,830 lb
150M1200EG	12"	12 3/4"	7/8"	4 1/4"	16 15/16"	13 5/8"	6,730 lb
150M1400EG	14"	14"	7/8"	4 1/4"	18 3/16"	14 7/8"	6,730 lb
150M1600EG	16"	16"	7/8"	4 1/4"	20 3/16"	16 7/8"	6,730 lb
150M1800EG	18"	18"	1"	4 3/4"	22 11/16"	19"	8,850 lb



150M Standard U-Bolt

Part Number	Pipe Size	Outer Diameter OD	Rod Size RS	Screw Length L	A	B	Static Load F
Material: Steel – Finish: Hot-dip galvanized							
150M0075HD	3/4"	1.050"	1/4"	2 3/8"	3 9/16"	1 5/16"	435 lb
150M0100HD	1"	1.315"	1/4"	2 3/8"	3 11/16"	1 9/16"	435 lb
150M0125HD	1 1/4"	1.660"	3/8"	2 3/8"	4 1/8"	2 1/16"	1,090 lb
150M0150HD	1 1/2"	1.900"	3/8"	2 1/2"	4 5/16"	2 1/4"	1,090 lb
150M0200HD	2"	2 3/8"	3/8"	2 1/2"	4 13/16"	2 3/4"	1,090 lb
150M0250HD	2 1/2"	2 7/8"	1/2"	3"	5 3/4"	3 3/8"	2,020 lb
150M0300HD	3"	3 1/2"	1/2"	3"	6 5/16"	4"	2,020 lb
150M0400HD	4"	4 1/2"	1/2"	3"	7 5/16"	5"	2,020 lb
150M0500HD	5"	5 9/16"	1/2"	3"	8 5/16"	6 1/16"	2,020 lb
150M0600HD	6"	6 5/8"	5/8"	3 3/4"	10 1/8"	7 1/4"	3,230 lb
150M0800HD	8"	8 5/8"	5/8"	3 3/4"	12 1/8"	9 1/4"	3,230 lb
150M1000HD	10"	10 3/4"	3/4"	4"	14 9/16"	11 1/2"	4,830 lb
150M1200HD	12"	12 3/4"	7/8"	4 1/4"	16 15/16"	13 5/8"	6,730 lb
150M1400HD	14"	14"	7/8"	4 1/4"	18 3/16"	14 7/8"	6,730 lb
150M1600HD	16"	16"	7/8"	4 1/4"	20 3/16"	16 7/8"	6,730 lb
Material: Steel – Finish: Plain							
150M0050PL	1/2"	0.840"	1/4"	2 3/8"	3 1/2"	1 1/16"	435 lb
150M0075PL	3/4"	1.050"	1/4"	2 3/8"	3 9/16"	1 5/16"	435 lb
150M0100PL	1"	1.315"	1/4"	2 3/8"	3 11/16"	1 9/16"	435 lb
150M0125PL	1 1/4"	1.660"	3/8"	2 3/8"	4 1/8"	2 1/16"	1,090 lb
150M0150PL	1 1/2"	1.900"	3/8"	2 1/2"	4 5/16"	2 1/4"	1,090 lb
150M0200PL	2"	2 3/8"	3/8"	2 1/2"	4 13/16"	2 3/4"	1,090 lb
150M0250PL	2 1/2"	2 7/8"	1/2"	3"	5 3/4"	3 3/8"	2,020 lb
150M0300PL	3"	3 1/2"	1/2"	3"	6 5/16"	4"	2,020 lb
150M0400PL	4"	4 1/2"	1/2"	3"	7 5/16"	5"	2,020 lb
150M0500PL	5"	5 9/16"	1/2"	3"	8 5/16"	6 1/16"	2,020 lb
150M0600PL	6"	6 5/8"	5/8"	3 3/4"	10 1/8"	7 1/4"	3,230 lb
150M0800PL	8"	8 5/8"	5/8"	3 3/4"	12 1/8"	9 1/4"	3,230 lb
150M1000PL	10"	10 3/4"	3/4"	4"	14 9/16"	11 1/2"	4,830 lb
150M1200PL	12"	12 3/4"	7/8"	4 1/4"	16 15/16"	13 5/8"	6,730 lb
150M1400PL	14"	14"	7/8"	4 1/4"	18 3/16"	14 7/8"	6,730 lb
150M1600PL	16"	16"	7/8"	4 1/4"	20 3/16"	16 7/8"	6,730 lb
150M1800PL	18"	18"	1"	4 3/4"	22 11/16"	19"	8,850 lb
Material: Stainless steel 304							
150M0050S4	1/2"	0.840"	1/4"	2 3/8"	3 1/2"	1 1/16"	435 lb
150M0075S4	3/4"	1.050"	1/4"	2 3/8"	3 9/16"	1 5/16"	435 lb
150M0100S4	1"	1.315"	1/4"	2 3/8"	3 11/16"	1 9/16"	435 lb
150M0125S4	1 1/4"	1.660"	3/8"	2 3/8"	4 1/8"	2 1/16"	1,090 lb
150M0150S4	1 1/2"	1.900"	3/8"	2 1/2"	4 5/16"	2 1/4"	1,090 lb
150M0200S4	2"	2 3/8"	3/8"	2 1/2"	4 13/16"	2 3/4"	1,090 lb
150M0250S4	2 1/2"	2 7/8"	1/2"	3"	5 3/4"	3 3/8"	2,020 lb
150M0300S4	3"	3 1/2"	1/2"	3"	6 5/16"	4"	2,020 lb
150M0400S4	4"	4 1/2"	1/2"	3"	7 5/16"	5"	2,020 lb
150M0500S4	5"	5 9/16"	1/2"	3"	8 5/16"	6 1/16"	2,020 lb
150M0600S4	6"	6 5/8"	5/8"	3 3/4"	10 1/8"	7 1/4"	3,230 lb
150M0800S4	8"	8 5/8"	5/8"	3 3/4"	12 1/8"	9 1/4"	3,230 lb
150M1000S4	10"	10 3/4"	3/4"	4"	14 9/16"	11 1/2"	4,830 lb
150M1200S4	12"	12 3/4"	7/8"	4 1/4"	16 15/16"	13 5/8"	6,730 lb
150M1400S4	14"	14"	7/8"	4 1/4"	18 3/16"	14 7/8"	6,730 lb
150M1600S4	16"	16"	7/8"	4 1/4"	20 3/16"	16 7/8"	6,730 lb

EM-HEX Rod Coupler



Specifications

Material: Steel
Finish: Electro-galvanized



Part Number	Rod Size RS	Length L	Static Load F
0250025EG	1/4"	7/8"	240 lb
0250037EG	3/8"	1 3/4"	610 lb
0250050EG	1/2"	1 3/4"	1,130 lb
0250062EG	5/8"	2 1/8"	1,810 lb
0250075EG	3/4"	2 1/4"	2,710 lb
0250087EG	7/8"	2 1/2"	3,770 lb

25R Hex Rod Reducer



Features

- Threaded rod reducing coupling

Specifications

Material: Steel
Finish: Electro-galvanized

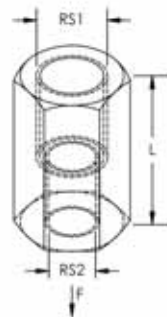

Part Number	Rod Size 1 RS1	Rod Size 2 RS2	Length L	Pipe Size	Static Load F
025R3725EG	3/8"	1/4"	1"	3/8" Max	240 lb
025R5037EG	1/2"	3/8"	1 1/4"	2" Max	610 lb
025R6250EG	5/8"	1/2"	1 1/4"	3 1/2" Max	1,130 lb

Never use smaller rod sizes than the minimum rod sizes defined by applicable code.



42 Hex Head Lag Screw



Features

- For use with wood structures

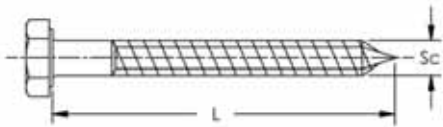

Specifications

Material: Steel

Finish: Electro-galvanized

Part Number	Screw Diameter Sc	Screw Length L
0422515EG	1/4"	1 1/2"
0422520EG	1/4"	2"
0423710EG	3/8"	1"
0423715EG	3/8"	1 1/2"
0423720EG	3/8"	2"
0423725EG	3/8"	2 1/2"
0423730EG	3/8"	3"
0423740EG	3/8"	4"
0425015EG	1/2"	1 1/2"
0425020EG	1/2"	2"
0425025EG	1/2"	2 1/2"
0425030EG	1/2"	3"
0425040EG	1/2"	4"

43 Wood Drive Screw



Features

- Light duty fastener for mounting various structural attachments onto wood

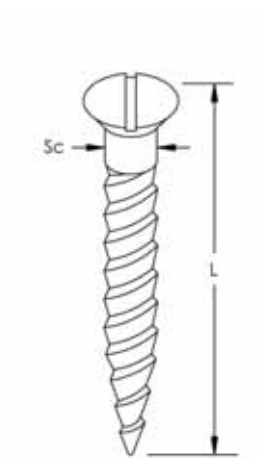

Specifications

Material: Steel

Finish: Electro-galvanized

Part Number	Screw Diameter Sc	Screw Length L
0431402EG	#14	2"
0431602EG	#16	2"

Install only in shear, never use under pull-out configuration.



80 Tie Bolt



Features

- Recommended for securing the connection of steel pipe to ductile pipe
- Threaded rod passes through eye and is retained with a Heavy Duty Hex Nut
- May be used for either vertical or horizontal installations

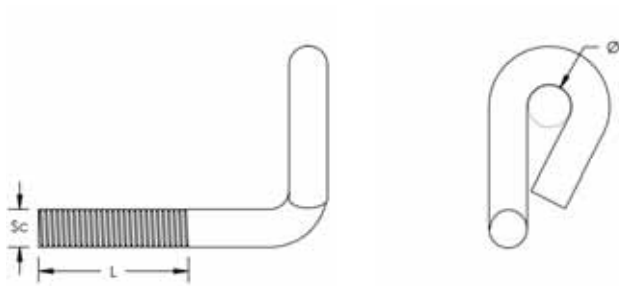

Specifications

Material: Steel

Part Number	Diameter	Screw Diameter Sc	Screw Length L
080750450PL	13/16"	3/4"	4 1/2"

Conforms to NFPA® pamphlet #2, 4"-12" pipe size.

Anchors



Drop-In Anchor
Page 112



Flanged Drop-in Anchor
Page 112



Spike Anchor
Page 113



Wedge Expansion
Anchor Bolt
Page 114



Concrete Anchor Screw
Page 115



Screw Drill Bits
Page 115



HangerMate® Vertical
Mount Screw for Steel
Page 116



HangerMate® Vertical Mount
Screw for Steel with Lock Nut
Page 116





HangerMate® Horizontal
Mount Screw for Steel
Page 117



HangerMate® Horizontal Mount
Screw for Steel with Lock Nut
Page 117



HangerMate® Vertical Mount
Screw for Wood
Page 118



HangerMate® Horizontal
Mount Screw for Wood
Page 118



HangerMate® Vertical Mount
Screw for Concrete
Page 119



HangerMate® SDS Drill Bit
for Hammer Drills
Page 119



HangerMate® Drill Bit
Adaptor
Page 120



HangerMate® Tanged Drill Bit
for Hammer Drills
Page 120

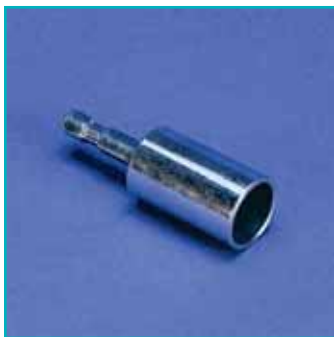

HangerMate® Hex
Drive Socket
Page 121



HangerMate® Drive Sleeve
Page 121

Drop-In Anchor



Features

- Internal thread provides easy removal and serviceability
- Installs flush or below the base surface

Specifications

Material: Steel
Finish: Plain

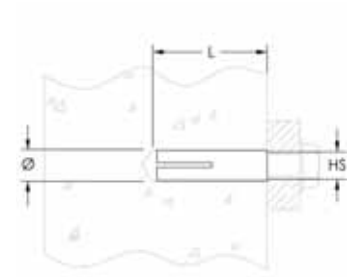

Part Number	Hole Size HS	Length L	Diameter
CA0025EG	1/4"	1"	3/8"
CA0037EG	3/8"	1 9/16"	1/2"
CA0050EG	1/2"	2"	5/8"

Flanged Drop-in Anchor



Features

- Internal thread provides easy removal and serviceability
- Installs flush for standard embedment

Specifications

Material: Steel
Finish: Plain

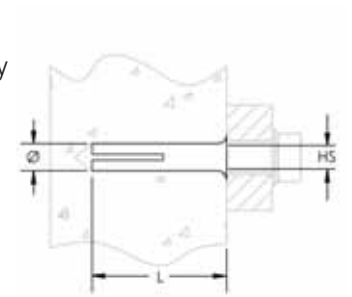

Part Number	Hole Size HS	Length L	Diameter
LA0025EG	1/4"	1"	3/8"
LA0037EG	3/8"	1 9/16"	1/2"
LA0050EG	1/2"	2"	5/8"



Spike Anchor



Features

- Use in concrete with threaded rod
- Vibration resistant
- Pre-expanded anchor design allows for easy installation
- Mushroom and flat head spike anchors are tamper-proof
- Removable forming spike can be used for temporary installations
- Pipe spike is an easy to install alternative to direct fastening



Specifications

Material: Steel

Finish: Electro-galvanized



Part Number	Rod Size RS	Drill Bit Size	Drill Hole Depth
RAWL3758	3/8"	1/4"	1 1/4"

Wedge Expansion Anchor Bolt



Features

- ICC approved for use in cracked and uncracked concrete
- Includes nut and washer
- Meets NFPA® 13 - 2010 as pre-qualified for seismic applications

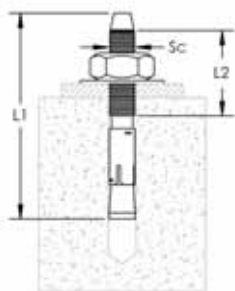

Specifications

Material: Steel

Finish: Electro-galvanized

Part Number	Screw Diameter Sc	Length 1 L1	Length 2 L2	Drill Bit Size	Torque TQ
CSBCAB030037EG	3/8"	3"	1 3/4"	3/8"	20 ft lb
CSBCAB037550EG	1/2"	3 3/4"	2 1/8"	1/2"	40 ft lb
CSBCAB045050EG	1/2"	4 1/2"	2 7/8"	1/2"	40 ft lb
CSBCAB055050EG	1/2"	5 1/2"	3 7/8"	1/2"	40 ft lb
CSBCAB047562EG	5/8"	4 3/4"	2 7/8"	5/8"	60 ft lb
CSBCAB060062EG	5/8"	6"	4 1/8"	5/8"	60 ft lb
CSBCAB055075EG	3/4"	5 1/2"	3 1/4"	3/4"	110 ft lb
CSBCAB062575EG	3/4"	6 1/4"	4"	3/4"	110 ft lb
CSBCAB070075EG	3/4"	7"	4 3/4"	3/4"	110 ft lb
CSBCAB085075EG	3/4"	8 1/2"	6 1/4"	3/4"	110 ft lb



Concrete Anchor Screw



Features

- For use with screw drill bits

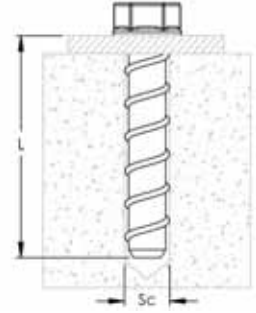

Specifications

Material: Steel

Finish: Electro-galvanized

Part Number	Screw Diameter Sc	Screw Length L	Drill Bit Size	Torque TQ
CSBCAS025037EG	3/8"	2 1/2"	3/8"	245 ft lb
CSBCAS030050EG	1/2"	3"	1/2"	300 ft lb
CSBCAS040050EG	1/2"	4"	1/2"	300 ft lb
CSBCAS050050EG	1/2"	5"	1/2"	300 ft lb
CSBCAS040062EG	5/8"	4"	5/8"	350 ft lb
CSBCAS050062EG	5/8"	5"	5/8"	350 ft lb
CSBCAS050075EG	3/4"	5"	3/4"	400 ft lb

Screw Drill Bits



Features

- For use with concrete anchor screws

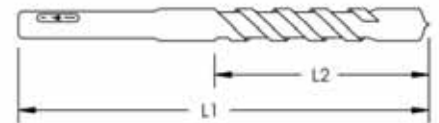

Specifications

Material: Steel

Part Number	Drill Bit Size	Length 1 L1	Length 2 L2
CSBCASDB060037	3/8"	6"	4"
CSBCASDB060050	1/2"	6"	4"
CSBCASDB080062	5/8"	8"	6"
CSBCASDB080075	3/4"	8"	6"
CSBCASDB100050	1/2"	10"	8"
CSBCASDB120062	5/8"	12"	10"

HangerMate® Vertical Mount Screw for Steel



Features

- Convenient design allows fast and easy installation
- Eliminates the need for labor-intensive operations, such as pre-punching or drilling of steel components
- Only one driver needed for all anchor sizes
- Tapped head permits in-line mounting of threaded rod systems

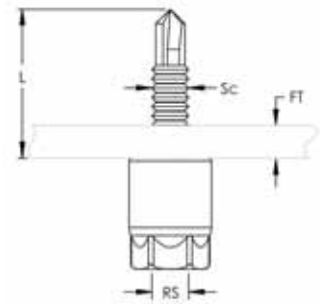

Specifications

Material: Steel

Finish: Electro-galvanized

Part Number	Rod Size RS	Flange Thickness FT	Screw Diameter Sc	Screw Length L
HMZG160	1/4"	0.06" – 1/4"	1/4"	1"
HMZG470	3/8"	0.06" – 1/4"	1/4"	1"

HangerMate® Vertical Mount Screw for Steel with Lock Nut



Features

- Convenient design allows fast and easy installation
- Eliminates the need for labor-intensive operations, such as pre-punching or drilling of steel components
- Only one driver needed for all anchor sizes
- Tapped head permits in-line mounting of threaded rod systems

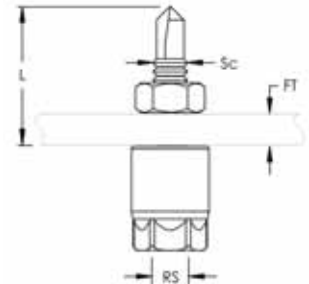

Specifications

Material: Steel

Finish: Electro-galvanized

Nut Included: Yes

Part Number	Rod Size RS	Flange Thickness FT	Screw Diameter Sc	Screw Length L
HMZG471	3/8"	0.06" – 1/4"	1/4"	1"



HangerMate® Horizontal Mount Screw for Steel



Features

- Convenient design allows fast and easy installation
- Eliminates the need for labor-intensive operations, such as pre-punching or drilling of steel components
- Only one driver needed for all anchor sizes
- Cross-drilled and tapped head permits horizontal mounting of threaded rod systems

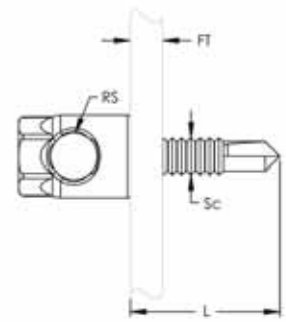

Specifications

Material: Steel

Finish: Electro-galvanized

Part Number	Rod Size RS	Flange Thickness FT	Screw Diameter Sc	Screw Length L
HMZH455	3/8"	0.060" – 1/8"	1/4"	1"
HMZH475	3/8"	0.060" – 1/4"	1/4"	1"

HangerMate® Horizontal Mount Screw for Steel with Lock Nut



Features

- Convenient design allows fast and easy installation
- Eliminates the need for labor-intensive operations, such as pre-punching or drilling of steel components
- Only one driver needed for all anchor sizes
- Cross-drilled and tapped head permits horizontal mounting of threaded rod systems

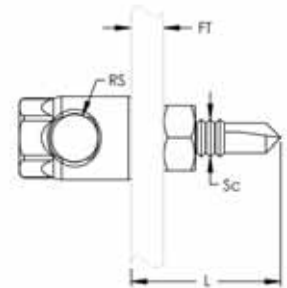

Specifications

Material: Steel

Finish: Electro-galvanized

Part Number	Rod Size RS	Flange Thickness FT	Screw Diameter Sc	Screw Length L
HMZH476	3/8"	0.06" – 1/4"	1/4"	1"

HangerMate® Vertical Mount Screw for Wood



Features

- Convenient design allows fast and easy installation
- Only one driver needed for all anchor sizes
- Tapped head permits in-line mounting of threaded rod systems

Specifications

Material: Steel
Finish: Electro-galvanized

Part Number	Rod Size	Screw Diameter	Screw Length
HMZG315	1/4"	5/16"	2 1/4"
HMZG650	3/8"	5/16"	2 1/4"

HangerMate® Horizontal Mount Screw for Wood



Features

- Convenient design allows fast and easy installation
- Only one driver needed for all anchor sizes
- Cross-drilled and tapped head permits horizontal mounting of threaded rod systems

Specifications

Material: Steel
Finish: Electro-galvanized

Part Number	Rod Size	Screw Diameter	Screw Length
HMZH665	3/8"	5/16"	2 1/4"



HangerMate® Vertical Mount Screw for Concrete



Features

- End-drilled and tapped for attaching threaded components to concrete
- Solid, one piece cold formed part; head cannot spin off or unscrew from body
- Tapered threads allow for easy starting in pre-drilled hole

Specifications

Material: Steel

Finish: Electro-galvanized

Part Number	Rod Size	Screw Diameter	Screw Length	Ultimate Static Load
HMZG365	1/4"	5/16"	2 1/4"	2,188 lb
HMZG730	3/8"	5/16"	2 1/4"	2,188 lb

Tested in 3650 psi concrete.

Appropriate safety factors should be applied for design purposes.

HangerMate® SDS Drill Bit for Hammer Drills



Features

- Engineered for accurate drilling in concrete applications
- Hex collar allows attachment of drive sleeve

Specifications

Material: Steel

Part Number	Drill Bit Size
HMZE350	1/4"
HMZE380	3/8"

HangerMate® Drill Bit Adaptor



Features

- Hex collar allows drive sleeve to be used with tanged drill bit

Specifications

Material: Steel

Part Number
HMZE240

HangerMate® Tanged Drill Bit for Hammer Drills



Features

- Engineered for accurate drilling in concrete applications
- For use with HangerMate® drill bit adaptor

Specifications

Material: Steel

Part Number	Drill Bit Size
HMZE340	1/4"



HangerMate® Hex Drive Socket



Features

- Installs anchors quickly and easily
- Automatically disengages when anchor is seated

Specifications

Material: Steel

Part Number
HMZE215

HangerMate® Drive Sleeve



Features

- Installs anchors quickly and easily
- Automatically disengages when anchor is seated
- Easily slips over drill bit adaptor and drill bits
- Allows installation of anchors without removing the drill bit

Specifications

Material: Steel

Part Number
HMZE220

Technical Information

DIMENSIONAL LEGEND

A	Adjustment	BS	Bolt Size
CL	Center Line	H	Height
HS	Hole Size	ID	Inside Diameter
L	Length	MRI	Minimum Rod Insertion
OD	Outside Diameter	PS	Pipe Size
R	Radius	RS	Rod Size
T	Thickness	W	Width

MATERIAL USED

CAST IRON:

Grey Cast Iron, ANSI®/ASTM® A 48-76, Class #20

MALLEABLE IRON:

ANSI/ASTM A 47-77, Grade Number 32510

SPRING STEEL:

High Carbon Steel, tempered.

STAINLESS STEEL:

(S4) ANSI Type 304 Stainless Steel: (S6) ANSI Type 316, ASTM A240

STEEL:

- M1020 Merchant Bar Quality, ANSI/ASTM A 36
- Prime Quality, Low Carbon, Hot Rolled Sheet, (may be Pickled and Oiled) ANSI/ASTM A 569
- Commercial Quality, Low Carbon, Cold Rolled, ANSI/ASTM A 366

INSTALLATION

1. All pipe supports, hangers, intermediate components and structural attachments must **ONLY** be used to support pipe, tubing or conduit as stated herein and are **NEVER** to be used for any other purpose.
2. All pipe supports and hangers are designed **ONLY** for **STATIONARY** piping unless otherwise noted.
3. All supports, hangers, clamps and accessories shown to use two nuts on the hanger rod or a jam nut must have nuts tightened securely to assure proper performance.

COATINGS

Zinc Electroplate, Electrogalvanized (EG)

ANSI/ASTM B633

This corrosion protective coating is applied after the fabrication of steel or malleable iron parts and uses an electrolytic plating process that deposits zinc up to 0.5 mils. A second passivation coating of chromate is then applied for additional protection.

Zinc electroplate products are recommended for indoor and mildly corrosive applications.

Pre-galvanized Zinc (PG)

ANSI/ASTM A 525 and 526

Pregalvanized zinc is produced by continuously rolling steel coils or sheets through molten zinc at the mills. The coils or sheets are slit to size and fabricated by forming, shearing or punching to produce the finished product. During fabrication cut edges are not generally zinc coated; however, the zinc near the uncoated metal becomes a sacrificial anode to protect the bare areas.

Pregalvanized zinc products are generally recommended for indoor use on mildly corrosive environments.

Hot Dip Galvanized Zinc (HDG)

ASTM A123

After a product has finished its fabrication process, it is dipped into a bath of molten zinc. The zinc completely coats all edges and surfaces. Zinc thickness is controlled by the time the part is immersed in the molten zinc bath.

Hot dip galvanized zinc products are recommended for indoor, outdoor and mildly corrosive environments.

IMPORTANT: For more detailed information on a specific product, application or application environment, please contact ERICO Engineering.

CADDY® ARMOUR

The CADDY® ARMOUR coating system features bi-metallic corrosion protection with an inorganic basecoat for sacrificial protection and an organic topcoat for barrier protection. The ERICO standard for CADDY ARMOUR includes at least 1,000 hours resistance against red rust when tested per the ASTM B117, DIN 50021, or ISO/R 1456 salt spray tests.

The CADDY ARMOUR manufacturing line is optimized to control heat energy, thereby minimizing fossil fuel use. Our energy-efficient coating process minimizes waste by reusing coatings in the process, rather than by burning off excess coatings, into the air. The entire coating process has been designed with a waste minimization approach, which allows the reuse of water and process streams.

CADDY® ARMOUR is RoHS compliant.

*Note : Spring steel fasteners are for indoor use in non-corrosive environments. Mild steel fasteners can be used outdoors in humid or mildly corrosive environments. Not to be used in certain areas such as over indoor pools, etc.



Technical Information

FIRE SPRINKLER WATER-FILLED WEIGHTS

Steel Pipe																					
Nominal Pipe Size		Schedule 40		Schedule 10		Schedule 5		Dyna Flow®		XL®		BLT®		EDDY Flow		EZ Flow™		Mega-Flow		Mega Thread	
in	mm	lb / ft	kg / m	lb / ft	kg / m	lb / ft	kg / m	lb / ft	kg / m	lb / ft	kg / m	lb / ft	kg / m	lb / ft	kg / m	lb / ft	kg / m	lb / ft	kg / m	lb / ft	kg / m
1	25	2.05	3.05	1.81	2.69	1.35	2.01	1.31	1.95	1.61	2.4	1.61	2.4	na	na	na	na	na	na	1.87	1.25
1 1/4	32	2.93	4.36	2.52	3.75	1.91	2.84	1.87	2.78	2.25	3.35	2.25	3.35	2.02	3.01	na	na	1.90	1.28	2.67	1.79
1 1/2	40	3.61	5.37	3.04	4.52	2.35	3.49	2.71	4.03	2.84	4.23	2.84	4.23	2.86	4.26	na	na	2.59	1.74	3.30	2.21
2	50	5.13	7.63	4.22	6.28	3.33	4.95	3.79	5.64	4.06	6.04	4.06	6.04	3.98	5.93	na	na	3.63	2.44	4.62	3.10
2 1/2	65	7.89	11.74	5.89	8.77	4.98	7.41	5.10	7.59	6.34	9.45	na	na	5.30	7.90	na	na	5.00	3.35	na	na
3	80	10.82	16.10	7.94	11.82	6.81	10.14	7.18	10.69	8.49	12.7	na	na	7.14	10.64	na	na	7.09	4.76	na	na
4	100	16.40	24.41	11.78	17.53	10.31	15.35	10.86	16.16	na	na	na	na	11.29	16.82	11.22	7.53	10.67	7.16	na	na
5	125	23.47	34.93	17.30	25.75	16.07	23.92	na	na	na	na	na	na	na	na	na	na	na	na	na	na
6	150	31.69	47.16	23.03	34.27	21.56	32.08	na	na	na	na	na	na	na	na	23.26	15.61	21.90	14.70	na	na
8	200	47.70	70.99	40.08	59.65	33.97	50.55	na	na	na	na	na	na	na	na	na	na	na	na	na	na

CPVC Pipe			
Nominal Pipe Size		BlazeMaster®	
in	mm	lb / ft	kg / m
3/4	20	0.43	0.64
1	25	0.68	1.00
1 1/4	32	1.08	1.61
1 1/2	40	1.42	2.11
2	50	2.22	3.31
2 1/2	65	3.26	4.84
3	80	4.83	7.19

Dyna-Flow is a registered trademark of Allied Tube and Conduit, a brand of Atkore International
 XL is a registered trademark of Allied Tube and Conduit, a brand of Atkore International
 BLT is a registered trademark of Allied Tube and Conduit, a brand of Atkore International
 Eddy Flow is a product of Bull Moose Tube Company
 EZ Flow is a trademark of Northwest Pipe Company
 Mega-Flow is a product of Wheatland Tube, JMC Steel Group
 Mega-Thread is a product of Wheatland Tube, JMC Steel Group
 BlazeMaster® is a registered trademark of The Lubrizol Corporation

Data Sources:

Dyna-Flow : http://www.alliedtube-sprinkler.com/pdf/STP1105_DynaFlow_Mcoat_Data.pdf
 XL : http://www.alliedtube-sprinkler.com/pdf/STP1105_XL_BLT_Mcoat_data.pdf
 BLT : http://www.alliedtube-sprinkler.com/pdf/STP1105_XL_BLT_Mcoat_data.pdf
 EDDY Flow : <http://www.bullmoosetube.com/downloads/downloads.asp?dldid=5>
 EZ Flow : http://nwpipe.com/Home_Redirect/Tubular_Products/
 Mega-Flow : http://www.wheatlandtube.ca/images/specs/SubmittalSheetRevised_MegaFlow.pdf
 Mega-Thread : http://www.wheatlandtube.ca/images/specs/SubmittalSheetRevised_MegaFlow.pdf
 BlazeMaster : http://newscenter.lubrizol.com/phoenix.zhtml?c=250972&p=irol-newsArticle_Print&ID=1650024&highlight=

HANGER SPACING

Pipe Hanger Spacing			
Nominal Dimensions		Max span between supports	
in	mm	ft	m
1	25	12	3.7
1 1/4	32	12	3.7
1 1/2	40	15	4.6
2	50	15	4.6
2 1/2	65	15	4.6
3	80	15	4.6
4	100	15	4.6
5	125	15	4.6
6	150	15	4.6
8	200	15	4.6
10	350	15	4.6
12	300	15	4.6

All piping systems require that the support system accommodate the weight of the pipe, joint connections, fluid, and other system components.

In general, the requirements of NFPA® 13 govern sprinkler system design

Spacing by NFPA 13 Sprinkler Systems (Steel Pipe except Threaded Lightwall)

Index

Part No.	Page	Part No.	Page	Part No.	Page	Part No.	Page
0250025EG	106	0503706EG	103	1050400S6	17	150M0075S4	105
0250037EG	106	0503706PL	103	1050500S4	17	150M0100EG	104
0250050EG	106	0503710EG	103	1050600S4	17	150M0100HD	105
0250062EG	106	0503710PL	103	1050600S6	17	150M0100PL	105
0250075EG	106	0503712EG	103	1050800S4	17	150M0100S4	105
0250087EG	106	0503712PL	103	1070075EG	27	150M0125EG	104
025R3725EG	106	0505006EG	103	1070100EG	27	150M0125HD	105
025R5037EG	106	0505006PL	103	1070125EG	27	150M0125PL	105
025R6250EG	106	0505010EG	103	1070150EG	27	150M0125S4	105
034SL0600EG	48	0505010PL	103	1070200EG	27	150M0150EG	104
034SL0800EG	48	0505012EG	103	1080075EG	28	150M0150HD	105
034SL1000EG	48	0505012PL	103	1080100EG	28	150M0150PL	105
034SL1200EG	48	0506206EG	103	1080125EG	28	150M0150S4	105
034SL1400EG	48	0506206PL	103	1080150EG	28	150M0200EG	104
0370037EG	57	0506210EG	103	1080200EG	28	150M0200HD	105
0370050EG	57	0506210PL	103	1090075EG	29	150M0200PL	105
0380037EG	58	0506212EG	103	1090100EG	29	150M0200S4	105
0422515EG	107	0506212PL	103	1090125EG	29	150M0250EG	104
0422520EG	107	0507506EG	103	1090150EG	29	150M0250HD	105
0423710EG	107	0507506PL	103	1090200EG	29	150M0250PL	105
0423715EG	107	0507510EG	103	1150050EG	15	150M0250S4	105
0423720EG	107	0507510PL	103	1150075EG	15	150M0300EG	104
0423725EG	107	0507512EG	103	1150100EG	15	150M0300HD	105
0423730EG	107	0507512PL	103	1150125EG	15	150M0300PL	105
0423740EG	107	0508706EG	103	1150150EG	15	150M0300S4	105
0425015EG	107	0508706PL	103	1150200EG	15	150M0400EG	104
0425020EG	107	0508710EG	103	1150250EG	15	150M0400HD	105
0425025EG	107	0508710PL	103	1150300EG	15	150M0400PL	105
0425030EG	107	0508712EG	103	1150350EG	15	150M0400S4	105
0425040EG	107	0508712PL	103	1150400EG	15	150M0500EG	104
0431402EG	108	080750450PL	109	1150500EG	15	150M0500HD	105
0431602EG	108	1050050S4	17	1150600EG	15	150M0500PL	105
0501010EG	103	1050075S4	17	1150800EG	15	150M0500S4	105
0501010PL	103	1050100S4	17	1351206EG	16	150M0600EG	104
0502506EG	103	1050125S4	17	1352006EG	16	150M0600HD	105
0502506PL	103	1050150S4	17	1353008EG	16	150M0600PL	105
0502510EG	103	1050200S4	17	1354008EG	16	150M0600S4	105
0502510PL	103	1050200S6	17	150M0050EG	104	150M0800EG	104
0502512EG	103	1050250S4	17	150M0050PL	105	150M0800HD	105
0502512PL	103	1050300S4	17	150M0050S4	105	150M0800PL	105
		1050300S6	17	150M0075EG	104	150M0800S4	105
		1050350S4	17	150M0075HD	105	150M1000EG	104
		1050400S4	17	150M0075PL	105	150M1000HD	105



Index

Part No.	Page	Part No.	Page	Part No.	Page	Part No.	Page
150M1000PL	105	300C7506EG	47	3530300PL	62	4010400EG	18
150M1000S4	105	300C7508EG	47	3530400PL	62	4010400HD	19
150M1200EG	104	300C7510EG	47	3550000PL	64	4010500EG	19
150M1200HD	105	300C7514EG	47	355N0025EG	65	4010500HD	19
150M1200PL	105	300C8706EG	47	355N0025PL	65	4010600EG	19
150M1200S4	105	300C8708EG	47	355N0037EG	65	4010600HD	19
150M1400EG	104	300C8714EG	47	355N0037PL	65	4010800EG	19
150M1400HD	105	304B2	33	355N0050PL	65	4010800HD	19
150M1400PL	105	3050037S4	46	355N0062PL	65	4011000EG	19
150M1400S4	105	3050050S4	46	355N0075EG	65	4011000HD	19
150M1600EG	104	3100037EG	45	355N0075PL	65	4011200EG	19
150M1600HD	105	3100037PL	45	355N0087EG	65	4011200HD	19
150M1600PL	105	3100050EG	45	355N0087PL	65	4011400EG	19
150M1600S4	105	3100050PL	45	3650037CP	59	4011600EG	19
150M1800EG	104	3150037EG	51	3650037EG	59	4011800EG	19
150M1800PL	105	3150037PL	51	3650037PL	59	4012000EG	19
3000037EG	44	3250037EG	52	365M0037CP	60	4012400EG	19
3000037PL	44	3250037PL	52	365M0037EG	60	4100050EG	20
3000050EG	44	3250050EG	52	365M0037PL	60	4100075EG	20
3000050PL	44	3250050PL	52	365M0050CP	60	4100100EG	20
3000062EG	44	3250062EG	52	365M0050EG	60	4100125EG	20
3000062PL	44	3250062PL	52	365M0050PL	60	4100150EG	20
3000075EG	44	3250075EG	52	370A0037PL	63	4100200EG	20
3000075PL	44	3250075PL	52	370A0050PL	63	4100250EG	20
3000087EG	44	3250087EG	52	370A0062PL	63	4100300EG	20
3000087PL	44	3250087PL	52	3TW	32	4100350EG	20
300C3706EG	47	3250100EG	52	4010050EG	18	4100400EG	20
300C3708EG	47	3250100PL	52	4010050HD	19	4100500EG	20
300C3710EG	47	3260037EG	54	4010075EG	18	4100600EG	20
300C3712EG	47	3260037PL	54	4010075HD	19	4100800EG	20
300C3714EG	47	3270037EG	53	4010100EG	18	4290050EG	31
300C3716EG	47	3270037PL	53	4010100HD	19	4290075EG	31
300C3718EG	47	3270050EG	53	4010125EG	18	4290100EG	31
300C5008EG	47	3270050PL	53	4010125HD	19	4290125EG	31
300C5010EG	47	3280037EG	56	4010150EG	18	4290150EG	31
300C5012EG	47	3280037PL	56	4010150HD	19	4290200EG	31
300C5014EG	47	3280050PL	56	4010200EG	18	4290250EG	31
300C5016EG	47	3290037EG	55	4010200HD	19	4290300EG	31
300C6206EG	47	3520100PL	61	4010250EG	18	4290350EG	31
300C6208EG	47	3520200PL	61	4010250HD	19	4290400EG	31
300C6210EG	47	3520300PL	61	4010300EG	18	4290500EG	31
300C6212EG	47	3530100PL	62	4010300HD	19	4550037EG	24
300C6214EG	47	3530200PL	62	4010350EG	18	4550037PL	24

Index

Part No.	Page	Part No.	Page	Part No.	Page	Part No.	Page
4550050EG	24	5100150HD	23	7210250PL	35	CSB18B00L7	88
4550050PL	24	5100150S4	23	7210300PL	35	CSB18BD38L10	87
4550075EG	24	5100200EG	22	7210400PL	35	CSB18BD38L7	87
4550075PL	24	5100200HD	23	7210500PL	35	CSB18BD50L10	87
4550100EG	24	5100200S4	23	7210600PL	35	CSB18BD50L7	87
4550100PL	24	5100250EG	22	7210800PL	35	CSB18CBL	86
4550125EG	24	5100250HD	23	7211000PL	35	CSB18SLVB	86
4550125PL	24	5100250S4	23	7211200PL	35	CSB3346SB	92
4550150EG	24	5100300EG	22	7211400PL	35	CSB36BD38L10	87
4550150PL	24	5100300HD	23	7211600PL	35	CSB36BD38L7	87
4550200EG	24	5100300S4	23	7211800PL	35	CSB36BD50L10	87
4550200PL	24	5100350EG	22	7212400PL	35	CSB36BD50L7	87
4550250EG	24	5100400EG	22	7220400PL	36	CSB36CBL	86
4550250PL	24	5100400HD	23	7220600PL	36	CSB36SLVB	86
4550300EG	24	5100400S4	23	7220800PL	36	CSB48	91
4550300PL	24	5100500EG	22	7221000PL	36	CSB48CBL	86
4550400EG	24	5100500HD	23	7230250PL	36	CSB48SLVB	86
4550400PL	24	5100500S4	23	7230300PL	36	CSBBARJEG	69
4560037CP	25	5100600EG	22	7230400PL	36	CSBBARJHD	69
4560050CP	25	5100600HD	23	7230600PL	36	CSBBARJSB50EG	82
4560075CP	25	5100600S4	23	7230800PL	36	CSBBC075EG	71
4560100CP	25	5100800EG	22	7240250PL	37	CSBBRP0100EG	94
4560125CP	25	5100800HD	23	7240300PL	37	CSBBRP0125EG	94
4560150CP	25	5100800S4	23	7240400PL	37	CSBBRP0150EG	94
4560200CP	25	5101000EG	23	7240600PL	37	CSBBRP0200EG	94
4560250CP	25	5101000S4	23	7240800PL	37	CSBBRS1EG	95
4560300CP	25	5101200EG	23	7241000PL	37	CSBBRS2EG	96
4560400CP	25	5101400EG	23	7241200PL	37	CSBBRS3EG	97
5100050EG	22	5101600EG	23	CA0025EG	112	CSBC9	91
5100050HD	23	5101800EG	23	CA0037EG	112	CSBCAB030037EG	114
5100050S4	23	5102000EG	23	CA0050EG	112	CSBCAB037550EG	114
5100075EG	22	5102400EG	23	CRLA37EG	40	CSBCAB045050EG	114
5100075S4	23	5120100EG	21	CRLB37EG	39	CSBCAB047562EG	114
5100100EG	22	5120125EG	21	CSB12B00L10	88	CSBCAB055050EG	114
5100100HD	23	5120150EG	21	CSB12B00L7	88	CSBCAB055075EG	114
5100100S4	23	5120200EG	21	CSB12BD38L10	87	CSBCAB060062EG	114
5100125EG	22	5120250EG	21	CSB12BD38L7	87	CSBCAB062575EG	114
5100125HD	23	5120300EG	21	CSB12BD50L10	87	CSBCAB070075EG	114
5100125S4	23	5120400EG	21	CSB12BD50L7	87	CSBCAB085075EG	114
5100150EG	22	5120500EG	21	CSB12CBL	86	CSBCAS025037EG	115
		5120600EG	21	CSB12SBHS	91	CSBCAS030050EG	115
		5470037PL	51	CSB12SLVB	86	CSBCAS040050EG	115
		5480050PL	51	CSB18B00L10	88	CSBCAS040062EG	115



Index

Part No.	Page	Part No.	Page	Part No.	Page	Part No.	Page
CSBCAS050050EG	115	CSBIB075145EG	70	CSBSTU0600HD	76	PHSW6	50
CSBCAS050062EG	115	CSBIB075145HD	70	CSBSTU0800EG	76	PHSW6FP	50
CSBCAS050075EG	115	CSBIB125180EG	70	CSBSTU0800HD	76	RAWL3758	113
CSBCASDB060037	115	CSBIB125180HD	70	CSBSTU1000EG	76	SN25	41
CSBCASDB060050	115	CSBIBSB50EG	82	CSBSTU1000HD	76	SN37	41
CSBCASDB080062	115	CSBIBSN37EG	82	CSBUNIV050EG	73	SN50	41
CSBCASDB080075	115	CSBMA050050EG	72	CSBUNIV050HD	73	SOSR075	30
CSBCASDB100050	115	CSBMA050075EG	72	CSBUNIV075EG	73	SOSR075B10	30
CSBCASDB120062	115	CSBNPC12	88	CSBUNIVSB62EG	82	SOSR100	30
CSBDI23	92	CSBQG0250EG	80	CSBURC12	89	SOSR100B10	30
CSBDI24	92	CSBQG0300EG	80	CSBURC38	89	SOSR125	30
CSBDI26	92	CSBQG0400EG	80	CSBURC4812	89	SOSR125B10	30
CSBDI28	92	CSBQG0500EG	80	CSBURC4834	89	SOSR150	30
CSBEZU0100EG	74	CSBQG0600EG	80	CSBURC4858	89	SOSR150B10	30
CSBEZU0100EG	75	CSBQG0800EG	80	CSBURC58	89	SOSR200	30
CSBEZU0100EG	75	CSBQIKCL0100EG	78	CSBURCR12	90	SOSR200B10	30
CSBEZU0125EG	74	CSBQIKCL0125EG	78	CSBURCR38	90	SR6	16
CSBEZU0125EG	75	CSBQIKCL0150EG	78	CSBURCR58	90		
CSBEZU0125EG	75	CSBQIKCL0200EG	78	ESGFP	32		
CSBEZU0150EG	74	CSBQIKCLSN37EG	82	HMZE215	121		
CSBEZU0150EG	75	CSBRS1	100	HMZE220	121		
CSBEZU0150EG	75	CSBRS37EG	101	HMZE240	120		
CSBEZU0200EG	74	CSBSH00375EG	99	HMZE340	120		
CSBEZU0200EG	75	CSBSH00500EG	99	HMZE350	119		
CSBEZU0200EG	75	CSBSH00625EG	99	HMZE380	119		
CSBEZU0250EG	74	CSBSH00750EG	99	HMZG160	116		
CSBEZU0250EG	75	CSBSTU0100EG	76	HMZG315	118		
CSBEZU0250EG	75	CSBSTU0100HD	76	HMZG365	119		
CSBEZU0300EG	74	CSBSTU0125EG	76	HMZG470	116		
CSBEZU0300EG	75	CSBSTU0125HD	76	HMZG471	116		
CSBEZU0300EG	75	CSBSTU0150EG	76	HMZG650	118		
CSBEZU0400EG	74	CSBSTU0150HD	76	HMZG730	119		
CSBEZU0400EG	75	CSBSTU0200EG	76	HMZH455	117		
CSBEZU0400EG	75	CSBSTU0200HD	76	HMZH475	117		
CSBEZU0500EG	74	CSBSTU0250EG	76	HMZH476	117		
CSBEZU0500EG	75	CSBSTU0250HD	76	HMZH665	118		
CSBEZU0500EG	75	CSBSTU0300EG	76	LA0025EG	112		
CSBEZU0600EG	74	CSBSTU0300HD	76	LA0037EG	112		
CSBEZU0600EG	75	CSBSTU0400EG	76	LA0050EG	112		
CSBEZU0600EG	75	CSBSTU0400HD	76	PH4	49		
CSBHS02	92	CSBSTU0500EG	76	PH6	49		
CSBIB075085EG	70	CSBSTU0500HD	76	PH6FP	49		
CSBIB075085HD	70	CSBSTU0600EG	76	PHSW4	50		

ERICO®



www.erico.com



AUSTRALIA
Phone 1-800-263-508
Fax 1-800-423-091



CHINA
Phone +86-21-3430-4878
Fax +86-21-5831-8177



HUNGARY
Phone 06-800-16538
Fax +39-0244-386-107



NORWAY
Phone 800-100-73
Fax 800-100-66



SWITZERLAND
Phone 0800-55-86-97
Fax 0800-55-96-15



BELGIUM
Phone 0800-757-48
Fax 0800-757-60



DENMARK
Phone 808-89-372
Fax 808-89-373



INDONESIA
Phone +62-21-575-0941
Fax +62-21-575-0942



POLAND
Phone +48-71-349-04-60
Fax +48-71-349-04-61



THAILAND
Phone +66-2-267-5776
Fax +66-2-636-6988



BRAZIL
Phone +55-11-3623-4333
Fax +55-11-3621-4066



FRANCE
Phone 0-800-901-793
Fax 0-800-902-024



ITALY
Phone 800-870-938
Fax 800-873-935



SINGAPORE
Phone +65-6-268-3433
Fax +65-6-268-1389



UNITED ARAB EMIRATES
Phone +971-4-881-7250
Fax +971-4-881-7270



CANADA
Phone +1-800-677-9089
Fax +1-800-677-8131



GERMANY
Phone 0-800-189-0272
Fax 0-800-189-0274



MEXICO
Phone +52-55-5260-5991
Fax +52-55-5260-3310



SPAIN
Phone 900-993-154
Fax 900-807-333



UNITED KINGDOM
Phone 0808-2344-670
Fax 0808-2344-676



CHILE
Phone +56-2-370-2908
Fax +56-2-369-5657



HONG KONG
Phone +852-2764-8808
Fax +852-2764-4486



NETHERLANDS
Phone 0800-0200-135
Fax 0800-0200-136



SWEDEN
Phone 020-790-908
Fax 020-798-964



UNITED STATES
Phone 1-800-753-9221
Fax +1-440-248-0723

WARNING

ERICO products shall be installed and used only as indicated in ERICO's product instruction sheets and training materials. Instruction sheets are available at www.erico.com and from your ERICO customer service representative. Improper installation, misuse, misapplication or other failure to completely follow ERICO's instructions and warnings may cause product malfunction, property damage, serious bodily injury and death.

WARRANTY

ERICO products are warranted to be free from defects in material and workmanship at the time of shipment. NO OTHER WARRANTY, WHETHER EXPRESS OR IMPLIED (INCLUDING ANY WARRANTY OF MERCHANTABILITY OR FITNESS FOR A PARTICULAR PURPOSE), SHALL EXIST IN CONNECTION WITH THE SALE OR USE OF ANY ERICO PRODUCTS. Claims for errors, shortages, defects or nonconformities ascertainable upon inspection must be made in writing within 5 days after Buyer's receipt of products. All other claims must be made in writing to ERICO within 6 months from the date of shipment or transport. Products claimed to be nonconforming or defective must, upon ERICO's prior written approval in accordance with its standard terms and procedures governing returns, promptly be returned to ERICO for inspection. Claims not made as provided above and within the applicable time period will be barred. ERICO shall in no event be responsible if the products have not been stored or used in accordance with its specifications and recommended procedures. ERICO will, at its option, either repair or replace nonconforming or defective products for which it is responsible or return the purchase price to the Buyer. THE FOREGOING STATES BUYER'S EXCLUSIVE REMEDY FOR ANY BREACH OF ERICO WARRANTY AND FOR ANY CLAIM, WHETHER SOUNDING IN CONTRACT, TORT OR NEGLIGENCE, FOR LOSS OR INJURY CAUSED BY THE SALE OR USE OF ANY PRODUCT.

LIMITATION OF LIABILITY

ERICO excludes all liability except such liability that is directly attributable to the willful or gross negligence of ERICO's employees. Should ERICO be held liable its liability shall in no event exceed the total purchase price under the contract. ERICO SHALL IN NO EVENT BE RESPONSIBLE FOR ANY LOSS OF BUSINESS OR PROFITS, DOWNTIME OR DELAY, LABOR, REPAIR OR MATERIAL COSTS OR ANY SIMILAR OR DISSIMILAR CONSEQUENTIAL LOSS OR DAMAGE INCURRED BY BUYER.

ANSI is a registered trademark of American National Standards Institute. cULus is a registered certification mark of UL LLC. FM is a registered certification mark of FM Approvals LLC, LTD. HangerMate is a registered trademark of Acument Intellectual Properties, LLC. NFPA is a registered trademark of National Fire Protection Association, Inc. UL is a registered certification mark of UL LLC.

Copyright ©2012 ERICO International Corporation. All rights reserved.

CADDY, CADWELD, CRITEC, ERICO, ERIFLEX, ERITECH, and LENTON are registered trademarks of ERICO International Corporation.

M1116C-NAEN DM744LT12NAEN WB1012