

PRODUCT SPECIFICATIONS

Elkay ezH2O[®] Retrofit Bottle Filling Station with SwirlFlo[®] Fountain Filtered Refrigerated Stainless. Chilling Capacity of 8.0 GPH (gallons per hour) of 50° F drinking water, based on 80° F inlet water and 90° F ambient, per ASHRAE 18 testing. Features shall include Antimicrobial, Filtered, Green Ticker[™], Hands Free, Laminar Flow, Real Drain, Visual Filter Monitor. Furnished with Flexi-Guard[®] Safety Bubbler. Electronic Bottle Filler Sensor with Mechanical Front Bubbler Button activation. Product shall be Wall Mount (Inwall Frame/Plate), for Indoor applications, serving 2 station(s). Unit shall be certified to UL 399 and CAN/CSA C22.2 No. 120.



Special Features:	Antimicrobial, Filtered, Green Ticker [™] , Hands Free, Laminar Flow, Real Drain, Visual Filter Monitor
Finish:	Stainless Steel
Power:	115V/60Hz
Bubbler Style:	Flexi-Guard [®] Safety Bubbler
Activation by:	Electronic Bottle Filler Sensor with Mechanical Front Bubbler Button
Mounting Type:	Wall Mount (Inwall Frame/Plate)
Chilling Capacity*:	8.0 GPH
Full Load Amps	1
Rated Watts:	15
Dimensions (L x W x H):	38-1/2" x 19" x 40-13/16"
Approx. Shipping Weight:	50 lbs.
Installation Location:	Indoor
No. of Stations Served:	2
*Based on 80° F inlet water & 90° F ambient air temp for 50° F chilled drinking water.	

Special Note: Need product compatibility info? Find retrofit compatibility guide under the product downloads section.

- Mechanically-Activated bubbler continues to supply water in event of service disruptions.
- Visual Filter Monitor: LED Filter Status Indicator for when filter change is necessary.
- Filter is certified to NSF 42 and 53 for lead, cyst, particulate, chlorine, taste and odor reduction. 3,000 gal. capacity.
- Green Ticker: Informs user of number of 20 oz. plastic water bottles saved from waste.
- Laminar flow provides clean fill with minimal splash.
- Silver Ion Antimicrobial protection on key plastic components to inhibit the growth of mold and mildew.
- Real Drain System eliminates standing water.

COOLING SYSTEM

- Compressor: Hermetically-sealed, reciprocating type,

PART: _____ QTY: _____

PROJECT: _____

CONTACT: _____

DATE: _____

NOTES: _____

APPROVAL: _____

Included with Product: Integral Bottle Filling Station, Filter, Panels, Mounting Frame

Ships in one box.

A Century of Tradition and Quality. For more than 100 years, Elkay has been making innovative products and providing exceptional customer care. We take pride in offering plumbing products that make life easier, inspire change and leave the world a better place.



PRODUCT COMPLIANCE

- ADA & ICC A117.1
- Buy American Act
- CAN/CSA C22.2 No. 120
- GreenSpec[®]
- NSF/ANSI 42, 53, 61, & 372 (lead free)
- UL 399



Complies with ADA & ICC A117.1 accessibility requirements when installed according to the requirements outlined in these standards. Installation may require additional components and/or construction features to be fully compliant. Consult the local Authority Having Jurisdiction if necessary.

- [Installation Instructions \(PDF\) - 200000500](#)
- [Installation Instructions \(PDF\) - Bottle Filling Station Retrofit Kit Compatibility Guide](#)





5 Year Limited Warranty on the refrigeration system of the unit. Electrical components and water system are warranted for 12 months from date of installation. **Warranty pertains to drinking water applications only. Non-drinking water applications are not covered under warranty.**

[Warranty \(PDF\)](#)

In keeping with our policy of continuing product improvement, Elkay reserves the right to change product specifications without notice. Please visit elkay.com for the most current version of Elkay product specification sheets. This specification describes an Elkay product with design, quality, and functional benefits to the user. When making a comparison of other producers' offerings, be certain these features are not overlooked.

single phase. Sealed-in lifetime lubrication.

- Condenser: Fan cooled, copper tube with aluminum fins. Fan motor is permanently lubricated.
- Cooling Unit: Combination tube-tank type. Continuous copper tubing with is fully insulated with EPS foam that meets UL requirements for self-extinguishing material.
- Refrigerant Control: Refrigerant R-134a is controlled by accurately calibrated capillary tube.
- Temperature Control: Easily accessible enclosed adjustable thermostat is factory preset. Requires no adjustment other than for altitude requirements.

Optional Accessories		
51300C	Elkay WaterSentry Replacement Filter (Bottle Fillers & Liv Pro) Spec Sheet (PDF)	
LKAPR1	Elkay Cane Apron for SwirlFlo Gray Spec Sheet (PDF)	
WSF6000R-2PK	WaterSentry 6000 CTO Replacement Filter (2pack) Spec Sheet (PDF)	
ACCESS12X38-5	Stainless Steel Access Panel for Bi-Level Architectural Fountains Spec Sheet (PDF)	

In keeping with our policy of continuing product improvement, Elkay reserves the right to change product specifications without notice. Please visit elkay.com for the most current version of Elkay product specification sheets. This specification describes an Elkay product with design, quality, and functional benefits to the user. When making a comparison of other producers' offerings, be certain these features are not overlooked.

IMPORTANT!

LZWS-ERP8-RF Retro-fit is designed to fit on an existing SwirlFlo® refrigerated style fountain which is properly installed per the Spec Sheet rough-in information.

ELECTRICAL

LZWS-ERP8-RF equipped with electrical cord and three-prong molded rubber plug for use with 15-amp minimum receptacle. Rated at 115V/60Hz, single phase.

These products are designed to operate on 20 psi to 105 psi supply line pressure.

OPERATION OF QUICK CONNECT FITTINGS

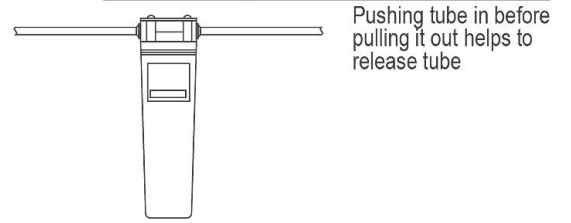
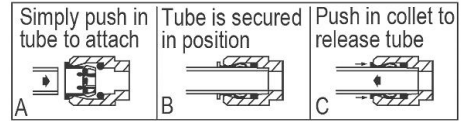

WaterSentry® Plus Filter System

**BOTTLE FILLER / FOUNTAIN INSTALLATION
AFTER RETRO-FIT CONVERSION**

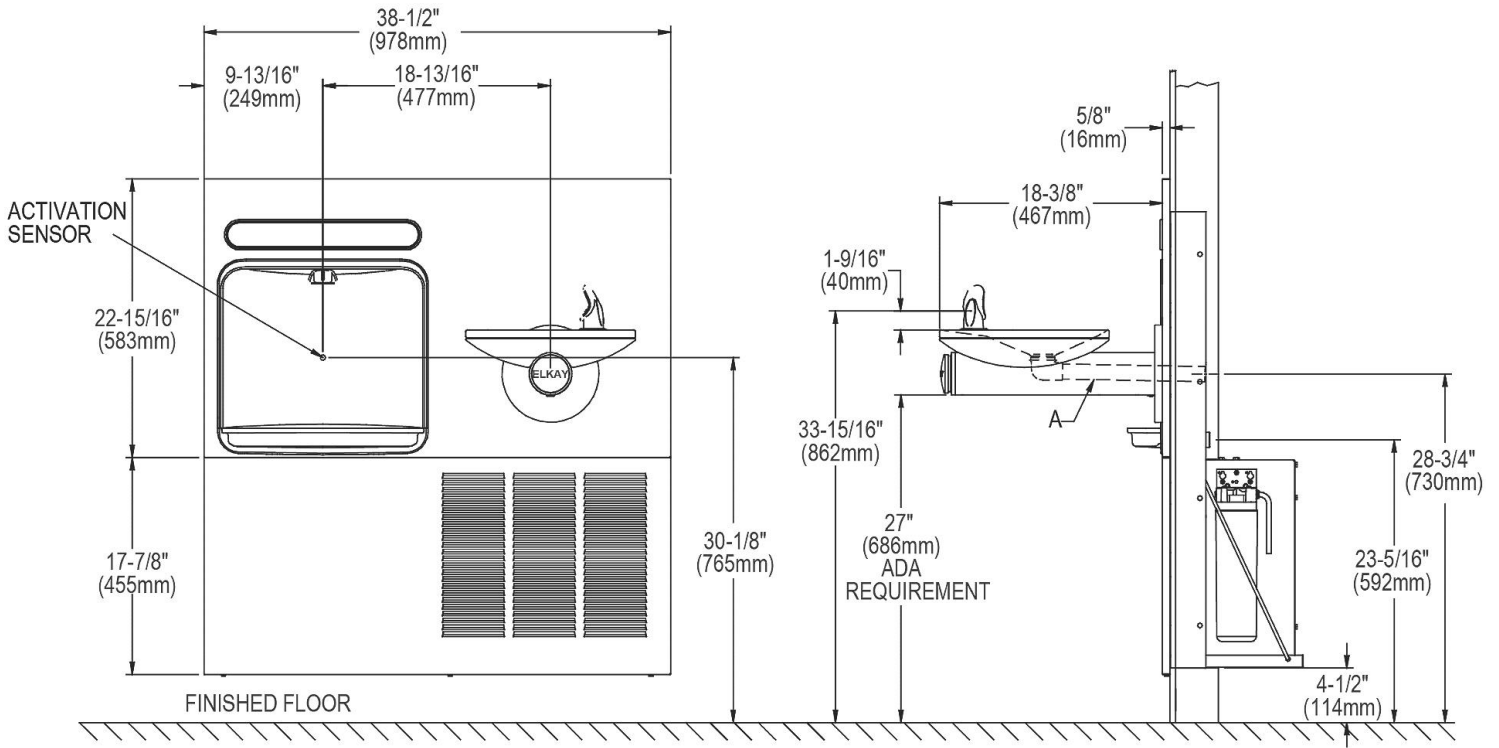

NOTE : New Installations Must Use Ground Fault Circuit Interrupter (GFCI).
It is highly recommended that the circuit be dedicated and the load protection be sized for 20 amps.

In keeping with our policy of continuing product improvement, Elkay reserves the right to change product specifications without notice. Please visit elkay.com for the most current version of Elkay product specification sheets. This specification describes an Elkay product with design, quality, and functional benefits to the user. When making a comparison of other producers' offerings, be certain these features are not overlooked.

MOUNTING FRAME 0000001052

IMPORTANT!

Retro-fit is designed to fit on an existing SwirlFlo® refrigerated style fountain which is properly installed per the Spec Sheet rough-in information.

ELECTRICAL

This unit is equipped with electrical cord and three-prong molded rubber plug for use with 15-amp minimum receptacle. Rated at 115V/60Hz, single phase.

INSTALLATION STEPS

Disassemble current Bi-Level Refrigerated fountain installation

Remove left hand mounting frame, replace with new open frame (included)

Reassemble installation with new upper panel / Bottle Filler assembly, original fountain, original lower mounting frame, chiller shelf, chiller unit and new lower panel assembly

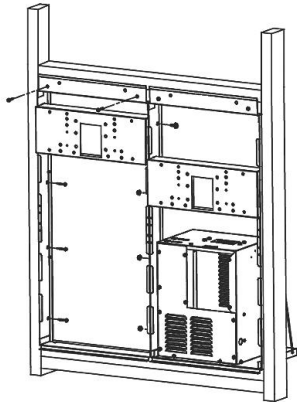

Typical current installation with fountains and panels removed

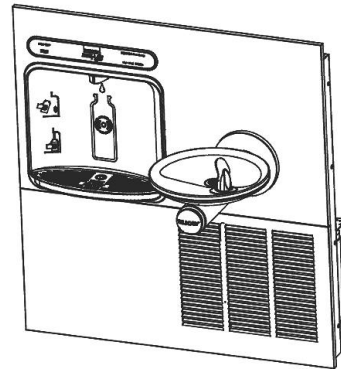
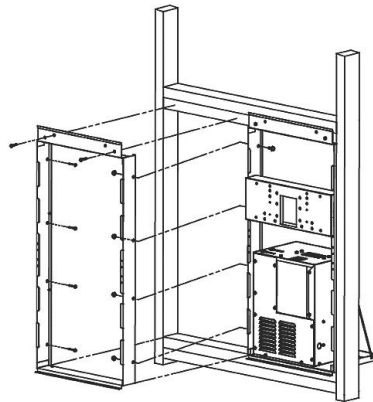

BOTTLE FILLER / FOUNTAIN INSTALLATION AFTER RETRO-FIT CONVERSION

In keeping with our policy of continuing product improvement, Elkay reserves the right to change product specifications without notice. Please visit elkay.com for the most current version of Elkay product specification sheets. This specification describes an Elkay product with design, quality, and functional benefits to the user. When making a comparison of other producers' offerings, be certain these features are not overlooked.