

SPLITTYPE ROOM AIR CONDITIONER

INSTALLATION MANUAL

(PART NO. 9379069458)

English

IMPORTANT!

Please Read Before Starting

This air conditioning system meets strict safety and operating standards. As the installer or service person, it is an important part of your job to install or service the system so it operates safely and efficiently.

For safe installation and trouble-free operation, you must:

- Carefully read this instruction booklet before beginning.
- Follow each installation or repair step exactly as shown.
- Observe all local, state, and national electrical codes.
- Pay close attention to all danger, warning, and caution notices given in this manual.

WARNING: This symbol refers to a hazard or unsafe practice which can result in severe personal injury or death.

CAUTION: This symbol refers to a hazard or unsafe practice which can result in personal injury and the potential for product or property damage.

- Hazel alerting symbols



Electrical



Safety / alert

If Necessary, Get Help

These instructions are all you need for most installation sites and maintenance conditions. If you require help for a special problem, contact our sales/service outlet or your certified dealer for additional instructions.

In Case of Improper Installation

The manufacturer shall in no way be responsible for improper installation or maintenance service, including failure to follow the instructions in this document.

SPECIAL PRECAUTIONS

When Wiring

ELECTRICAL SHOCK CAN CAUSE SEVERE PERSONAL INJURY OR DEATH. ONLY A QUALIFIED, EXPERIENCED ELECTRICIAN SHOULD ATTEMPT TO WIRE THIS SYSTEM.

- Do not supply power to the unit until all wiring and tubing are completed or reconnected and checked.
- Highly dangerous electrical voltages are used in this system. Carefully refer to the wiring diagram and these instructions when wiring. Improper connections and inadequate earthing (grounding) can cause **accidental injury or death**.
- Earth (Ground) the unit** following local electrical codes.

- Connect all wiring tightly. Loose wiring may cause overheating at connection points and a possible fire hazard.

When Transporting

Be careful when picking up and moving the indoor and outdoor units. Get a partner to help, and bend your knees when lifting to reduce strain on your back. Sharp edges or thin aluminum fins on the air conditioner can cut your fingers.

When Installing...

...In a Ceiling or Wall

Make sure the ceiling/wall is strong enough to hold the unit's weight. It may be necessary to construct a strong wood or metal frame to provide added support.

...In a Room

Properly insulate any tubing run inside a room to prevent "sweating" that can cause dripping and water damage to walls and floors.

...In Moist or Uneven Locations

Use a raised concrete pad or concrete blocks to provide a solid, level foundation for the outdoor unit. This prevents water damage and abnormal vibration.

...In an Area with High Winds

Securely anchor the outdoor unit down with bolts and a metal frame. Provide a suitable air baffle.

...In a Snowy Area (for Heat Pump-type Systems)

Install the outdoor unit on a raised platform that is higher than drifting snow. Provide snow vents.

When Connecting Refrigerant Tubing

- Keep all tubing runs as short as possible.
- Use the flare method for connecting tubing.
- Apply refrigerant lubricant to the matching surfaces of the flare and union tubes before connecting them, then tighten the nut with a torque wrench for a leak-free connection.
- Check carefully for leaks before starting the test run.

NOTE:

Depending on the system type, liquid and gas lines may be either narrow or wide. Therefore, to avoid confusion the refrigerant tubing for your particular model is specified as either "small" or "large" rather than as "liquid" or "gas".

When Servicing

- Turn the power OFF at the main circuit breaker panel before opening the unit to check or repair electrical parts and wiring.
- Keep your fingers and clothing away from any moving parts.
- Clean up the site after you finish, remembering to check that no metal scraps or bits of wiring have been left inside the unit being serviced.
- After installation, explain correct operation to the customer, using the operating manual.

This air conditioner uses new refrigerant HFC (R410A).

The basic installation work procedures are the same as conventional refrigerant (R22) models. However, pay careful attention to the following points:

- Since the working pressure is 1.6 times higher than that of conventional refrigerant (R22) models, some of the piping and installation and service tools are special. (See the table below.) Especially, when replacing a conventional refrigerant (R22) model with a new refrigerant R410A model, always replace the conventional piping and flare nuts with the R410A piping and flare nuts.
- Models that use refrigerant R410A have a different charging port thread diameter to prevent erroneous charging with conventional refrigerant (R22) and for safety. Therefore, check beforehand. [The charging port thread diameter for R410A is 1/2 threads per inch.]
- Be more careful that foreign matter (oil, water, etc.) does not enter the piping than with refrigerant (R22) models. Also, when storing the piping, securely seal the opening by pinching, taping, etc.
- When charging the refrigerant, take into account the slight change in the composition of the gas and liquid phases, and always charge from the liquid phase side whose composition is stable.

Special tools for R410A

Tool name	Contents of change
Gauge manifold	Pressure is high and cannot be measured with a conventional gauge. To prevent erroneous mixing of other refrigerants, the diameter of each port has been changed. It is recommended the gauge with seals-0.1 to 5.3 MPa (30 in.Hg to 768 psi) for high pressure. -0.1 to 3.8 MPa (30 in.Hg to 551 psi) for low pressure.
Charge hose	To increase pressure resistance, the hose material and base size were changed.
Vacuum pump	A conventional vacuum pump can be used by installing a vacuum pump adapter.
Gas leakage detector	Special gas leakage detector for HFC refrigerant R410A.

ELECTRICAL REQUIREMENT

Always make the air conditioner power supply a special branch circuit and provide a special switch and receptacle. Do not extend the power cable. Always select the size that corresponds to the capacity of the breaker to the size of the power cable.

CAUTION		
Outdoor unit capacity	MINIMUM CIRCUIT AMPACITY	MAX. CKT. BKR.
9, 12	14.3 A	15 A
15	18.1 A	20 A

Electric cable size:

Outdoor unit capacity	Cable	Cable size	Remarks
9, 12	Power supply cable	14AWG UL 1505	2 cable+Earth (Ground), 1φ 208/230 V
	Connection cable		3 cable+Earth (Ground), 1φ 208/230 V
15	Power supply cable	12AWG UL 1505	2 cable+Earth (Ground), 1φ 208/230 V
	Connection cable	14AWG UL 1505	3 cable+Earth (Ground), 1φ 208/230 V

- Install all electrical works in accordance to the national standard.
- Install the disconnect device with a contact gap of at least 3 mm in all poles nearby the units. (Both indoor unit and outdoor unit.)

Copper pipes

It is necessary to use seamless copper pipes and it is desirable that the amount of residual oil is less than 40 mg/10 m (0.004 oz / 100 ft.). Do not use copper pipes having a collapsed, deformed or discolored portion (especially on the interior surface). Otherwise, the expansion value or capillary tube may become blocked with contaminants.

As an air conditioner using R410A incurs pressure higher than when using R22, it is necessary to choose adequate materials. Thicknesses of copper pipes used with R410A are as shown in Table. Never use copper pipes thinner than 0.8 mm (0.032 in.) even when it is available on the market.

Thicknesses of Annealed Copper Pipes

Nominal diameter (in.)	Outer diameter (mm)	Thickness [mm (in.)]	
		R410A	[ref.] R22
1/4	6.35	0.80 (0.032)	0.80 (0.032)
3/8	9.52		
1/2	12.7		

WARNING

- Do not use the existing (for R22) piping and flare nuts.
 - If the existing materials are used, the pressure inside the refrigerant cycle will rise and cause breakage, injury, etc. (Use the special R410A materials.)
- When installing and relocating the air conditioner, do not mix gases other than the specified refrigerant(R410A) to enter the refrigerant cycle.
 - If air or other gas enters the refrigerant cycle, the pressure inside the cycle will rise to an abnormally high value and cause breakage, injury, etc.

For authorized service personnel only.

WARNING

- For the room air conditioner to operate satisfactory, install it as outlined in this installation manual.
- Connect the indoor unit and outdoor unit with the air conditioner piping and cords available standards parts. This installation manual describes the correct connections using the standard accessories and the parts specified in this installation manual.
- Have installation work done by authorized service personnel only.
- Do not use an extension cord.
- Do not turn on the power until all installation work is complete.

CAUTION

This installation manual describes how to install the outdoor unit only. To install the indoor unit, refer to the installation manual included with the indoor unit.

- Be careful not to scratch the air conditioner when handling it.
- After installation, explain correct operation to the customer, using the operating manual.
- Let the customer keep this installation manual because it is used when the air conditioner is serviced or moved.

Pipe length		Max. height
Max.	Min.	
20 m (65 ft.)	3 m (10 ft.)	15 m (49 ft.)

OUTDOOR UNIT INSTALLATION

- Set the unit on a strong stand, such as one made of concrete blocks to minimize shock and vibration.
- Do not set the unit directly on the ground because it will cause trouble.

Connector cover removal

- Remove the tapping screw.

Installing the connector cover

- After inserting the five hooks, then push upward.
- Tighten the tapping screw.

WARNING

- Install the unit where it will not be tilted by more than 5°.
- When installing the outdoor unit where it may be exposed to strong wind, fasten it securely.

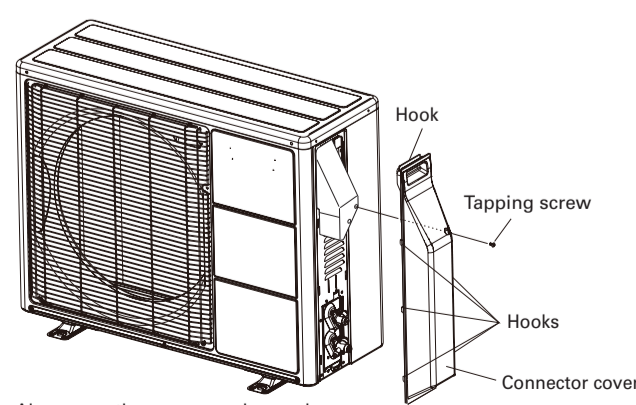

Always use the screws as shown above.

SELECTING THE MOUNTING POSITION

Decide the mounting position with the customer as follows:

- If possible, do not install the unit where it will be exposed to direct sunlight. (If necessary, install a blind that does not interfere with the air flow.)
- Do not install the unit where a strong wind blows or where it is very dusty.
- Do not install the unit where people pass.
- Take your neighbors into consideration so that they are not disturbed by air blowing into their windows or by noise.
- Provide the space shown in the figure so that the air flow is not blocked. Also for efficient operation, leave open three of the four directions front, rear, and both sides.
- Please set it up in the place where has no influence on dropping the drain water from the outdoor unit.

WARNING

Install at a place that can withstand the weight of the outdoor units and install positively so that the units will not topple or fall.

CAUTION

- Do not install where there is the danger of combustible gas leakage.
- Do not install near heat sources.
- If children under 10 years old may approach the unit, take preventive measures so that they cannot reach the unit.
- Do not place any other electrical products or household belongings under indoor unit or outdoor unit. Dripping condensation from the unit might get them wet, and may cause damage or malfunction of your property.

INSTALLATION DIAGRAM OF OUTDOOR UNIT

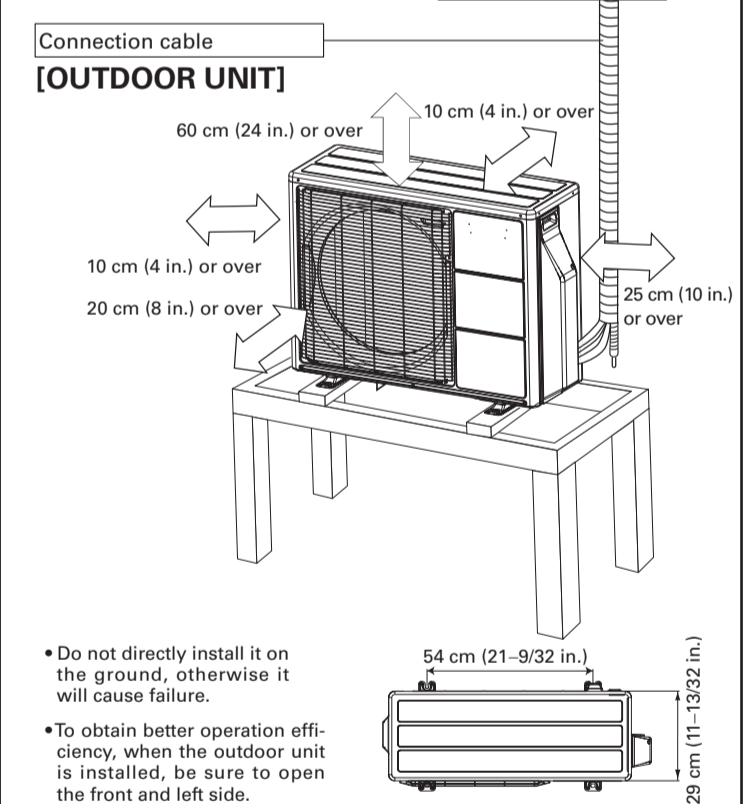

- Do not directly install it on the ground, otherwise it will cause failure.
- To obtain better operation efficiency, when the outdoor unit is installed, be sure to open the front and left side.

CAUTION

- In places where the outdoor temperature drops to 32°F (0°C) or lower, the drain water may freeze and may stop up the drain or cause other outdoor unit trouble. Therefore take measures so that the drain water will not freeze and clog the drain.
- Please set up the outdoor unit in a high place and please do not arrange the frame of installed stand under the drain port, because the water dropped from the drain port repeats freezing and accumulating, and may block the drain port.
- In the area with heavy snowfall, if the intake and outlet of outdoor unit is blocked with snow, it might become difficult to get warm and it is likely to be because of the breakdown. Please construct a canopy or baffle board. (local configured).

POWER

WARNING

- The rated voltage of this product is 208/230 V AC 60 Hz.
- Before turning on the power, check if the voltage is within the 208 V -10 % to 230 V +10 % range.
- Always use a special branch circuit and install a special disconnect switch to supply power to the room air conditioner.
- Use a circuit breaker and disconnect switch matched to the capacity of the air conditioner.
- Do not extend the power cable.
- Perform wiring work in accordance with standards so that the air conditioner can be operated safely and positively.
- Install a leakage circuit breaker in accordance with the related laws and regulations and electric company standards.

CAUTION

- The power source capacity must be the sum of the air conditioner current and the current of other electrical appliances. When the current contracted capacity is insufficient, change the contracted capacity.
- When the voltage is low and the air conditioner is difficult to start, contact the power company the voltage raised.

OUTDOOR UNIT WIRING

- Remove the tapping screw, then remove the control box cover.
- Fasten the Inter-unit wire harness and power supply to the conduit holder using the lock nut.
- Connect inter-unit wire harness and power supply to the terminal.
- Use the tapping screw to install the control box cover.

WARNING

Be sure to comply with local codes while running the wire from the indoor unit to the outdoor unit (size of wire and wiring method, etc.).

Every wire must be connected firmly.

No wire should be allowed to touch refrigerant tubing, the compressor or any moving part.

Loose wiring may cause the terminal to overheat or result in unit malfunction. A fire hazard may also exist. Therefore, be sure all wiring is tightly connected.

Connect wires to the matching numbers of terminals.

NOTE:

- Connector trade size for this unit is 12.7 mm (1/2 in.). The connector can be bought at a hardware store. Refer to "How to connect wiring to the terminals" for instructions on connecting depending on the wire type you are using.
- The fuse located in the outdoor unit provides power supply protection and may blow when power is applied if the system has been in correctly wired.

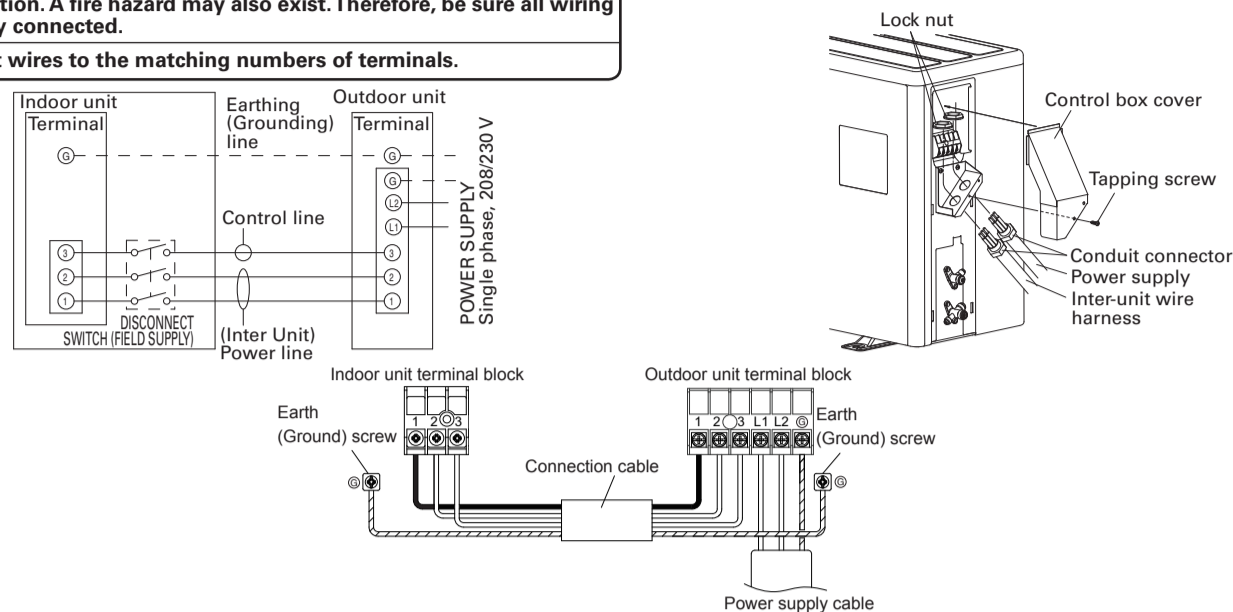

CAUTION

- Match the terminal block numbers and connection cord colors with those of the indoor unit. Erroneous wiring may cause burning of the electric parts.
- Connect the connection cords firmly to the terminal block. Imperfect installation may cause a fire.
- Always fasten the outside covering of the connection cord with the cord clamp. (If the insulator is chafed, electric leakage may occur.)
- Securely earth (ground) the power cord.
- Do not use the earth (ground) screw for an external connector. Only use for interconnection between two units.

PUMP DOWN OPERATION (FORCED COOLING OPERATION)

To avoid discharging refrigerant into the atmosphere at the time of relocation or disposal, recover refrigerant by doing the cooling operation or forced cooling operation according to the following procedure. (When the cooling operation cannot start in winter, and so on, start the forced cooling operation.)

- Do the air purging of the charge hose by connecting the charging hose of gauge manifold to the charging port of 3 way valve and opening the low-pressure valve slightly.
- Close the valve stem of 2 way valve completely.
- Start the cooling operation or following forced cooling operation. Keep on pressing the MANUAL AUTO button of the indoor unit for more than 10 seconds. The operation indicator lamp and timer indicator lamp will begin to flash simultaneously during test run. (The forced cooling operation cannot start if the MANUAL AUTO button is not kept on pressing for more than 10 seconds.)
- Close the valve stem of 3 way valve when the reading on the compound pressure gage becomes 0.05~0 MPa (7.25~0 psi).
- Stop the operation.
 - Press the START/STOP button of the remote control unit to stop the operation.
 - Press the MANUAL AUTO button when stopping the operation from indoor unit side.
 (It is not necessary to press on keeping for more than 10 seconds.)

CAUTION

During the pump-down operation, make sure that the compressor is turned off before you remove the refrigerant piping. Do not remove the connection pipe while the compressor is in operation with 2 way or 3 way valve open. This may cause abnormal pressure in the refrigeration cycle that leads to breakage and even injury.

OPERATING RANGE

	Cooling/Dry Mode	Heating Mode
Outdoor temperature	About 14 to 115 °F	About -15 to 75 °F

CONNECTING THE PIPING

CONNECTION

- Install the outdoor unit wall cap (supplied with the optional installation set or procured at the site) to the wall pipe.
- Connect the outdoor unit and indoor unit piping.
- After matching the center of the flare surface and tightening the nut hand tight, tighten the nut to the specified tightening torque with a torque wrench. (Table 1)

FLARING

- Cut the connection pipe to the necessary length with a pipe cutter.
- Hold the pipe downward so that cuttings will not enter the pipe and remove the burrs.
- Insert the flare nut onto the pipe and flare the pipe with a flaring tool.

Insert the flare nut (always use the flare nut attached to the indoor and outdoor units respectively) onto the pipe and perform the flare processing with a flare tool. Use the special R410A flare tool, or the conventional (for R22) flare tool. When using the conventional flare tool, always use an allowance adjustment gauge and secure the A dimension shown in table 2.

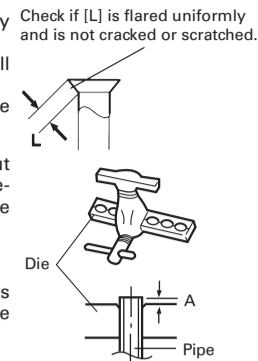

BENDING PIPES

- When bending the pipe, be careful not to crush it.
- To prevent breaking of the pipe, avoid sharp bends. Bend the pipe with a radius of curvature of 70 mm (2-13/16 in.) or over.
- If the copper pipe is bent the pipe or pulled to often, it will become stiff. Do not bend the pipes more than three times at one place.

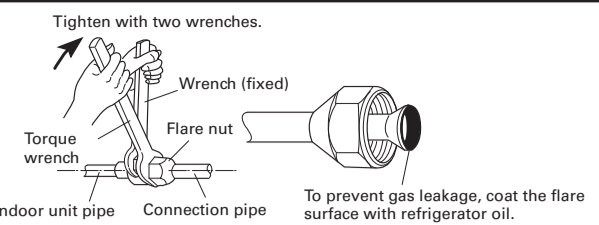

Table 1 Flare nut tightening torque

Flare nut [mm (in.)]	Tightening torque [N·m (lbf·ft)]
6.35 (1/4) dia.	16 to 18 (11.8 to 13.3)
9.52 (3/8) dia.	32 to 42 (23.6 to 31.0)
12.70 (1/2) dia.	49 to 61 (36.1 to 45.0)

Table 2 Pipe outside diameter

Pipe outside diameter [mm (in.)]	A [mm (in.)]	
	Flare tool for R410A, clutch type	Conventional (R22) flare tool
6.35 (1/4)	Clutch type	Wing nut type
9.52 (3/8)	0 to 0.5 (0 to 1/32)	0.5 to 1.5 (1/32 to 2/32)
12.70 (1/2)		1.5 to 2.0 (2/32 to 3/32)

CAUTION

- Fasten a flare nut with a torque wrench as instructed in this manual. If fastened too tight, the flare nut may be broken after a long period of time and cause a leakage of refrigerant.
- During installation, make sure that the refrigerant pipe is attached firmly before you run the compressor. Do not operate the compressor under the condition of refrigerant piping not attached properly with 2-way or 3-way valve open. This may cause abnormal pressure in the refrigeration cycle that leads to breakage and even injury.

AIR PURGE

Always use a vacuum pump to purge the air. Refrigerant for purging the air is not charged in the outdoor unit at the factory.

Close the high pressure side valve of the gauge manifold fully and do not operate it during the following work.

- Check if the piping connections are secure.
- Check that the stems of 2-way valve and 3-way valve are closed fully.
- Connect the gauge manifold charge hose to the charging port of the 3-way valve (side with the projection for pushing in the valve core).
- Open the low pressure side valve of the gauge manifold fully.
- Operate the vacuum pump and start pump down.
- Slowly loosen the flare nut of the 3-way valve and check if air enters, then retighten the flare nut. (When the flare nut is loosened the operating sound of the vacuum pump changes and the reading of the compound pressure gauge goes from minus to zero.)
- Pump down the system for at least 15 minutes, then check if the compound pressure gauge reads -0.1 MPa (30 in.Hg).
- At the end of pump down, close the low pressure side gauge of the gauge manifold fully and stop the vacuum pump.
- Slowly loosen the valve stem of the 3-way valve. When the compound pressure gauge reading reaches 0.1~0.2 MPa (14.5~28.9 psi), retighten the valve stem and disconnect the charge hose from the 3-way valve charging port. (If the stem of the 3-way valve is opened fully before the charge hose is disconnected, it may be difficult to disconnect the charge hose.)

Additional charge

Refrigerant suitable for a piping length of 15 m (49 ft.) is charged in the outdoor unit at the factory. When the piping is longer than 15 m (49 ft.), additional charging is necessary. For the additional amount, see the table below.

Pipe length	15 m (49 ft.)	20 m (65 ft.)	Rate
Additional refrigerant	None	+3.5 oz (+100 g)	0.2 oz/ft (20 g/m)

CAUTION

- Refrigerant must not be discharged into atmosphere.
- After connecting the piping, check the joints for gas leakage with gas leak detector.

- Fully open the valve stems of the 2-way valve and 3-way valve using a hexagon wrench. (After the valve stem begins to turn, turn it with a torque of less than 2.9 N·m (30 kgf·cm) until it stops turning.)
- Firmly tighten the 2-way valve and 3-way valve blank cap and the charging port cap.

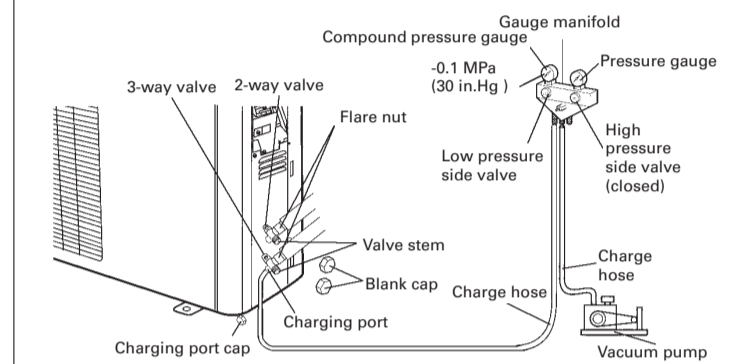

	Tightening torque [N·m (lbf·ft)]	
Blank cap	6.35 mm (1/4 in.)	20 to 25 (14.8 to 18.4)
	9.52 mm (3/8 in.)	
	12.70 mm (1/2 in.)	28 to 32 (20.7 to 23.6)
Charging port cap	10 to 12 (7.4 to 8.8)	

CAUTION

- When adding refrigerant, add the refrigerant from the charging port at the completion of work.
- The maximum length of the piping is 20 m (65 ft.). If the units are further apart than this, correct operation can not be guaranteed.

Between 15 m (49 ft.) and 20 m (65 ft.), when using a connection pipe other than that in the table, charge additional refrigerant with 0.2 oz/ft (20 g/m) as the criteria.