

AIR CONDITIONER

**Floor type**

# **DESIGN & TECHNICAL MANUAL**

---

---

INDOOR



AGU9RLF  
AGU12RLF  
AGU15RLF

---

OUTDOOR



AOU9RLFF  
AOU12RLFF  
AOU15RLFF

---

**FUJITSU GENERAL LIMITED**

# 1. INDOOR UNIT

---

**FLOOR TYPE :**

**AGU9RLF**

**AGU12RLF**

**AGU15RLF**

# CONTENTS

## 1. INDOOR UNIT

<b>1. FEATURES</b> .....	01 - 01
<b>2. WIRELESS REMOTE CONTROLLER</b> .....	01 - 04
<b>3. SPECIFICATIONS</b> .....	01 - 06
<b>4. DIMENSIONS</b> .....	01 - 07
<b>5. WIRING DIAGRAMS</b> .....	01 - 08
<b>6. CAPACITY TABLE</b> .....	01 - 09
6-1. COOLING CAPACITY .....	01 - 09
6-2. HEATING CAPACITY.....	01 - 11
<b>7. FAN PERFORMANCE AND CAPACITY</b> .....	01 - 13
7-1. AIR VELOCITY DISTRIBUTION.....	01 - 13
7-2. AIRFLOW.....	01 - 14
<b>8. OPERATION NOISE (SOUND PRESSURE)</b> .....	01 - 16
8-1. NOISE LEVEL CURVE .....	01 - 16
8-2. SOUND LEVEL CHECK POINT .....	01 - 18
<b>9. ELECTRIC CHARACTERISTICS</b> .....	01 - 19
<b>10. SAFETY DEVICES</b> .....	01 - 20
<b>11. EXTERNAL INPUT &amp; OUTPUT</b> .....	01 - 21
11-1. EXTERNAL INPUT .....	01 - 21
11-2. EXTERNAL OUTPUT.....	01 - 23
<b>12. FUNCTION SETTINGS</b> .....	01 - 25
12-1. INDOOR UNIT (Setting by remote controller).....	01 - 25
<b>13. OPTIONAL PARTS</b> .....	01 - 30
13-1. CONTROLLER.....	01 - 30
13-2. OTHERS.....	01 - 30

# 1. FEATURES

## ■ MODEL

AGU9RLF / AOU9RLFF  
 AGU12RLF / AOU12RLFF  
 AGU15RLF / AOU15RLFF



## ■ FEATURES

### ● Energy Efficiency

	MODEL		
	AGU9RLF	AGU12RLF	AGU15RLF
Seasonal Energy Efficiency Ratio (SEER)	26.0	22.7	20.3
Heating Seasonal Performance Factor (HSPF)	12.6	11.6	11.2

MEASUREMENT CONDITIONS  
 ANSI/ASHRAE STANDARD 37-1988

### ● 2-Fan & Wide airflow

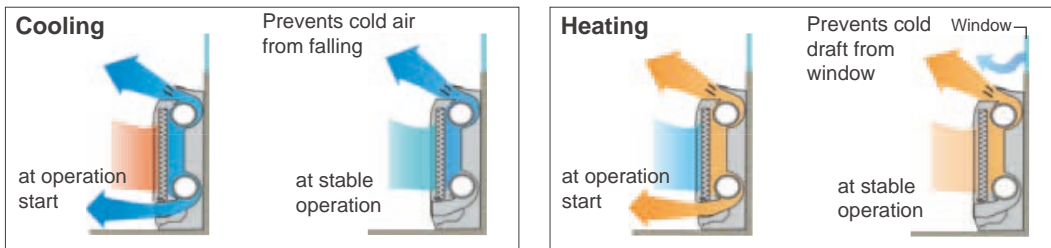

### ● Low outdoor air temperature correspondence

Corresponds to heating operation at -5 °F(-21°C) outdoor air temperature

Heating
<b>-5 to 75 °F</b> (-21 to 24°C)

### ● Powerful heating

Heating capacity was improved at low outdoor temperature. This new model can operate even at -5°F (-21°C) low outdoor temperature.

### ● Powerful operation

Continuous operation by maximum air flow and maximum compressor speed after a certain period of time allows the temperature to reach the setting temp. quickly.

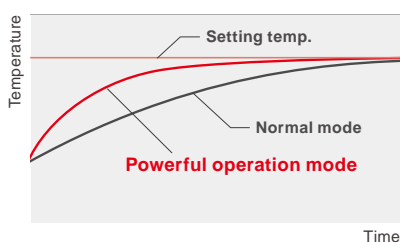

## ● Flexible & easy installation

Piping space is wide and connection work is easy.

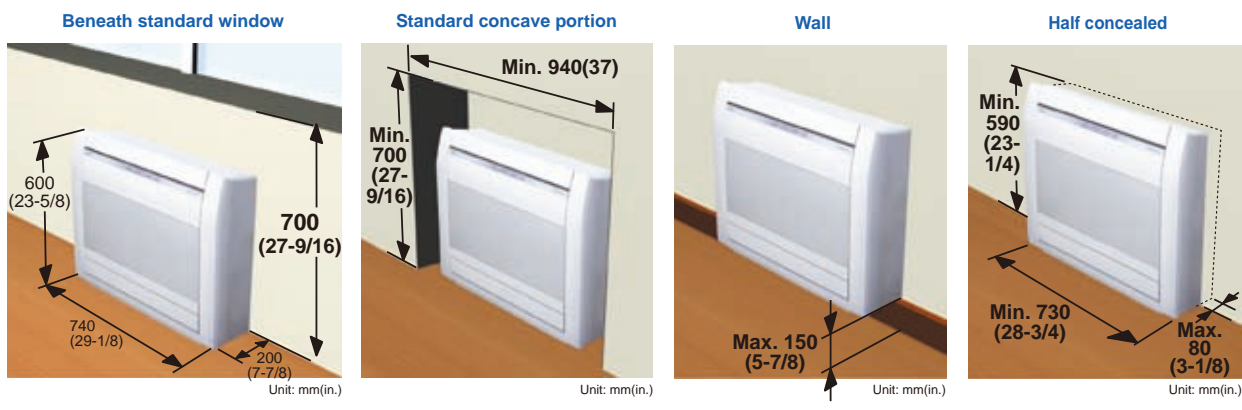

### Choice of 6-direction drain & piping connection

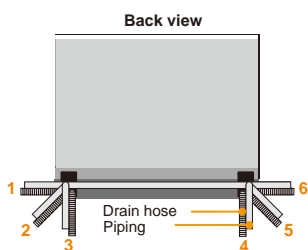

### Space is wide and piping work is easy

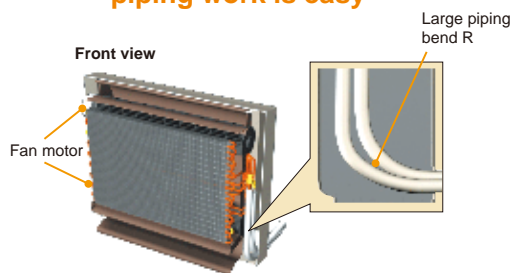

## ● Super quiet operation

Air flow mode can be set in 4 steps and more detailed air flow setting is possible.

## ● MIN. HEAT Operation \*Only available with Wireless RC.

The room temperature can be set to go no lower than 50°F (10°C), thus ensuring that the room does not get too cold when not occupied

Caution)

- When the room temperature is higher than 50°F (10°C), "MIN. HEAT" operation does not start. Operation starts and maintains the room temperature at 50°F (10°C) when the temperature drops below 50°F (10°C).
- When "MIN. HEAT" operation stops, the room set temperature quickly returns to the preset temperature.

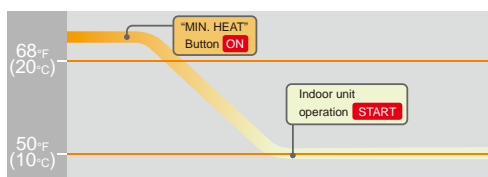

## ● Economy operation

Limits the maximum operation current, and the power consumption is cut down and the maximum load is suppressed.

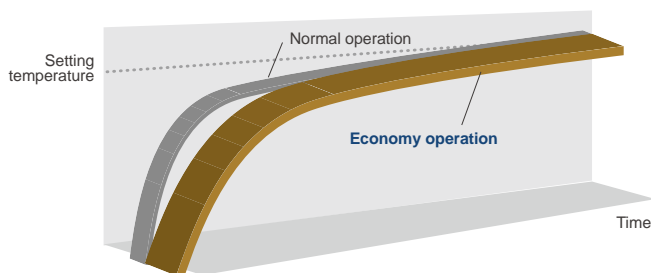

● **Air conditioner filter feature**

Apple-catechin filter



Long-life ion deodorization filter



## 2. WIRELESS REMOTE CONTROLLER

### ■ FEATURES



- \*4 mode timer setup available (ON / OFF / PROGRAM / SLEEP).
- \*Easy operation.
- \*Easy to change custom code (max. 4 custom codes) by button operation.

#### ● Simple function setting

Setting of the air conditioner selection function is performed by remote controller.

#### ● Built-in timers

Select from four different timer programs (On / Off / Program / Sleep).

#### ● Program timer

The program timer operates the on and off timer once within a 24-hour period.

#### ● Sleep timer

The sleep timer function automatically corrects the temperature thermostat setting according to the timer setting to prevent excessive cooling and heating while sleeping.

##### Cooling operation/dry operation

When the sleep timer is set, the set temperature automatically rises 2°F (1°C) every hour. The set temperature can rise up to a maximum of 4°F (2°C).

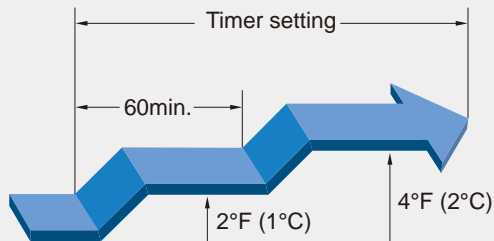

##### Heating operation

When the sleep timer is set, the set temperature automatically drops 2°F (1°C) every 30 minutes. The set temperature can drop to a maximum of 8°F (4°C).

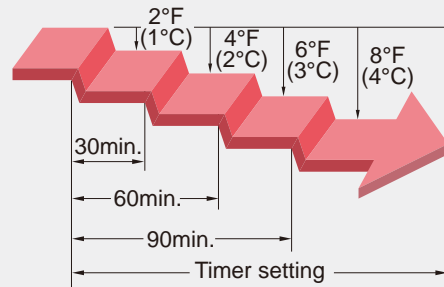

#### ● Simple function setting

Setting of the air conditioner selection function is performed by remote controller.

#### ● Switching remote controller custom code

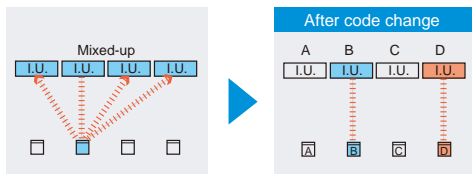

- Code selector switch eliminates unit being wrongly switched.  
(Up to 4 custom codes can be set.)

\*I.U.=Indoor unit

#### ● To change the temperature unit

Easy to change the temperature unit (°F ↔ °C) by button operation.

## FUNCTIONS

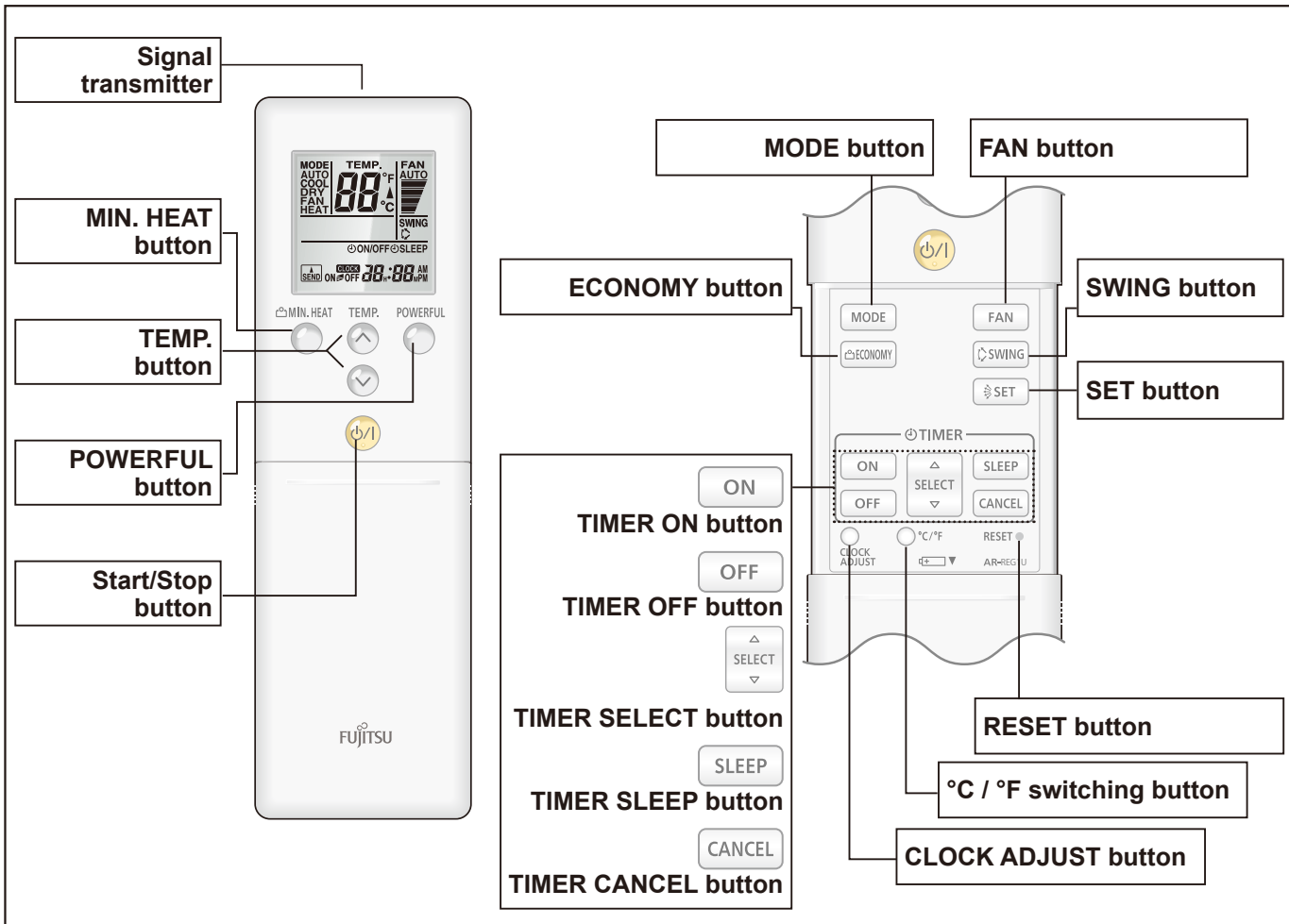

### Display panel

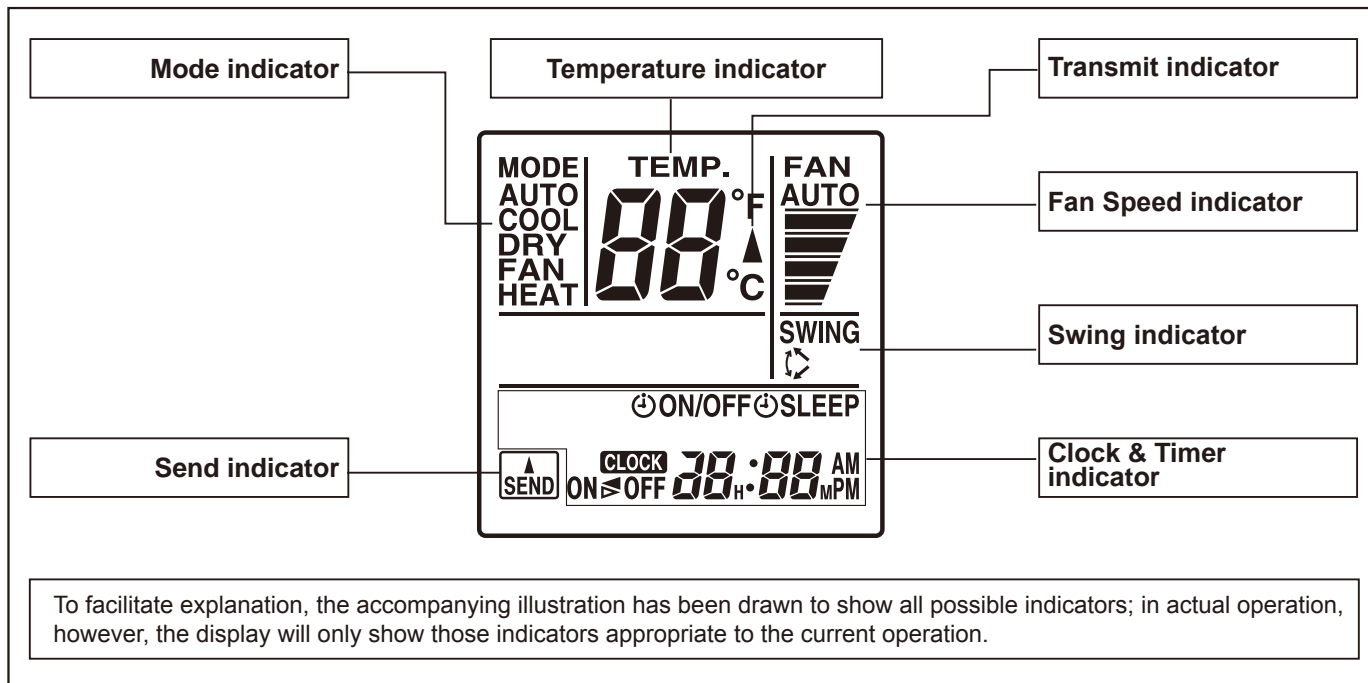

## SPECIFICATION

DIMENSIONS [H × W × D]: in. (mm)	8-1/16 (205) × 2-3/8 (61) × 11/16 (17)
WEIGHT oz. (g)	4.3 (122)
ACCESSORY	Holder

**NOTE:** Some button operations may not be available for all units or systems. For details, refer to the operation manual.



### 3. SPECIFICATIONS

Type				FLOOR TYPE			
				INVERTER HEAT PUMP			
Model name				AGU9RLF	AGU12RLF	AGU15RLF	
Power source				208 / 230V ~ 60Hz			
Available voltage range				187 - 253V ~ 60Hz			
Capacity	Cooling	Rated	kW	2.64	3.52	4.16	
			Btu/h	9000	12000	14,200	
		Min. - Max.	kW	0.90 - 3.80	0.90 - 4.20	0.90 - 5.20	
	Btu/h		3100 - 13,000	3100 - 14,300	3100 - 17,700		
	Heating	Rated	kW	3.52	4.69	5.28	
			Btu/h	12000	16000	18000	
Min. - Max.		kW	0.90 - 5.50	0.90 - 5.70	0.90 - 6.10		
	Btu/h	3100 - 18,800	3100 - 19,500	3100 - 20,800			
Input power	Cooling	Rated	kW	0.56	0.91	1.13	
				Min. - Max.	0.20 - 2.05	0.20 - 2.05	0.18 - 2.16
	Heating	Rated		0.88	1.44	1.58	
				Min. - Max.	0.20 - 2.62	0.20 - 2.62	0.18 - 3.30
Current	Cooling	Rated	A	2.9	4.2	5.1	
	Heating		4.1	6.7	7.0		
EER	Cooling		kW/kW	4.71	3.87	3.68	
			Btu/hW	16.0	13.1	12.5	
COP	Heating		kW/kW	4.00	3.27	3.34	
			Btu/hW	13.6	11.1	11.3	
SEER	Cooling		Btu/hW	26.0	22.7	20.3	
HSPF	Heating		Btu/hW	12.6	11.6	11.2	
Power factor	Cooling		%	84	94	96	
	Heating			93	93	98	
Moisture removal			pints/h (l/h)	2.7 (1.3)	3.8 (1.8)	4.4 (2.1)	
Maximum operating current *1	Cooling		A	9.3	9.3	9.8	
	Heating			10.8	10.8	13.8	
Fan	Cooling	High	CFM (m <sup>3</sup> /h)	336 (570)		383 (650)	
				Med	271 (460)		306 (520)
					Low	212 (360)	
				Quiet		159 (270)	
	Heating	High			353 (600)		383 (650)
				Med	283 (480)		306 (520)
					Low	218 (370)	
				Quiet		159 (270)	
	Type × Q'ty				Cross flow fan × 2		
	Motor output			W	16 × 2		
Sound pressure level	Cooling	High	dB (A)	40		44	
				Med	35		38
					Low	29	
				Quiet		23	
	Heating	High			40		43
				Med	35		37
					Low	29	
				Quiet		23	
Heat exchanger type	Dimensions (H × W × D)		in. (mm)		14-7/8 × 21-5/8 × 1-1/16 (378 × 550 × 26.6)		
	Fin pitch		FPI	21			
	Rows × Stages			2 × 18			
	Pipe type			Copper			
	Fin type			Aluminum			
Enclosure	Material		Polystyrene				
	Color		White Approximate color of MUNSELL N9.25/				
Dimensions (H × W × D)	Net		inch	23-5/8 × 29-1/8 × 7-7/8			
			mm	600 × 740 × 200			
	Gross		inch	27-9/16 × 32-5/16 × 12-3/16			
			mm	700 × 820 × 310			
Weight	Net		lbs. (kg)	31 (14)			
				Gross	37 (17)		
Connection pipe	Size	Liquid	in. (mm)	Ø1/4 (Ø6.35)			
		Gas		Ø3/8 (Ø9.52)	Ø1/2 (Ø12.70)		
	Method			Flare			
Operation range	Cooling		°F (°C)	64 to 90 (18 to 32)			
			%RH	80 or less			
	Heating		°F (°C)	60 to 88 (16 to 30)			
Remote controller type			Wireless				
Drain hose	Material		PP + LLDPE				
	Size		in.(mm)	Ø9/16(Ø13.8) (I.D.), Ø5/8 to Ø11/16(Ø15.8 to Ø16.7) (O.D.)			

**Note :**

Specifications are based on the following conditions.

Cooling : Indoor temperature of 80°F (26.67°C) DB / 67°F (19.44°C) WB, and outdoor temperature of 95°F (35°C) DB / 75°F (23.9°C) WB.

Heating : Indoor temperature of 70°F (21.11°C) DB / 59°F (15°C) WB, and outdoor temperature of 47°F (8.33°C) DB / 43°F (6.11°C) WB.

Pipe length : 24ft.(7.5m), Height difference:0 m. (Outdoor unit-Indoor unit)

The protective function might work when using it outside the operation range.

\*1: The maximum current is the maximum value when the operated within the operation range.

# 4. DIMENSIONS

## ■ MODEL: AGU9RLF, AGU12RLF, AGU15RLF

Unit: in. (mm)

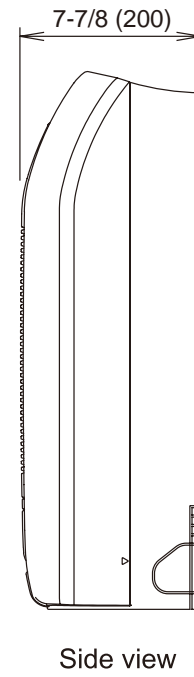
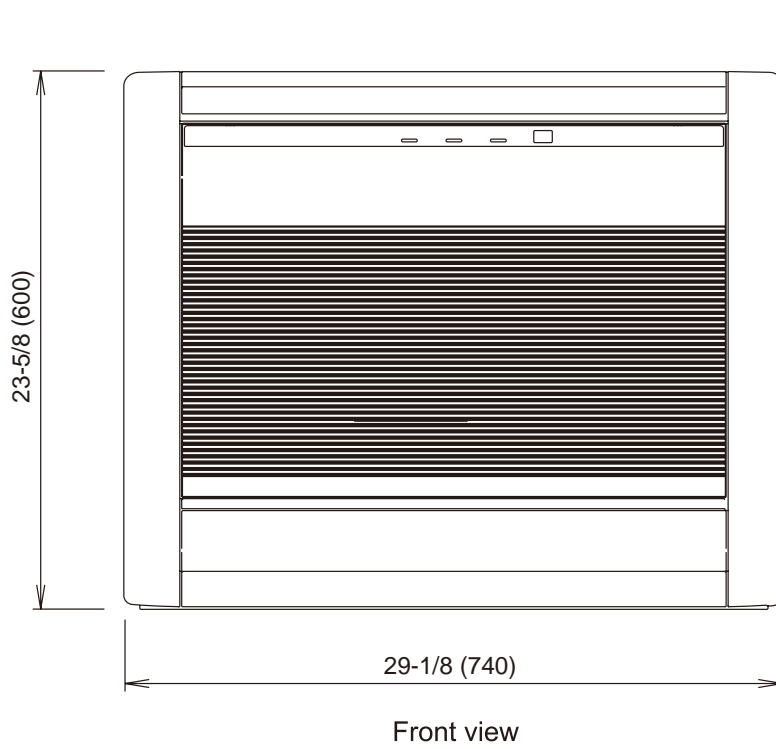

## ■ INSTALLATION PLACE

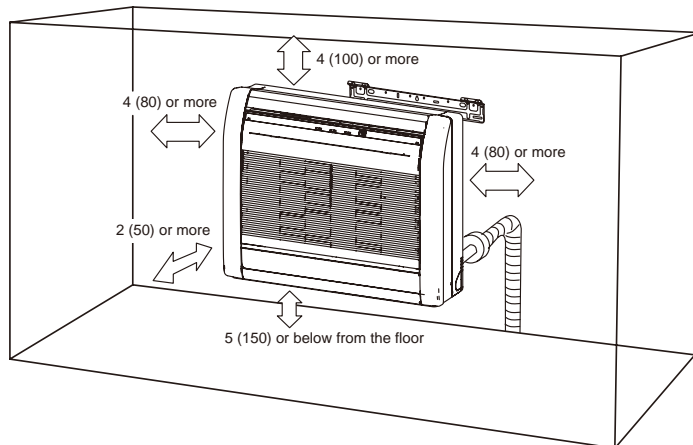

# 5. WIRING DIAGRAMS

## ■ MODEL: AGU9RLF, AGU12RLF, AGU15RLF

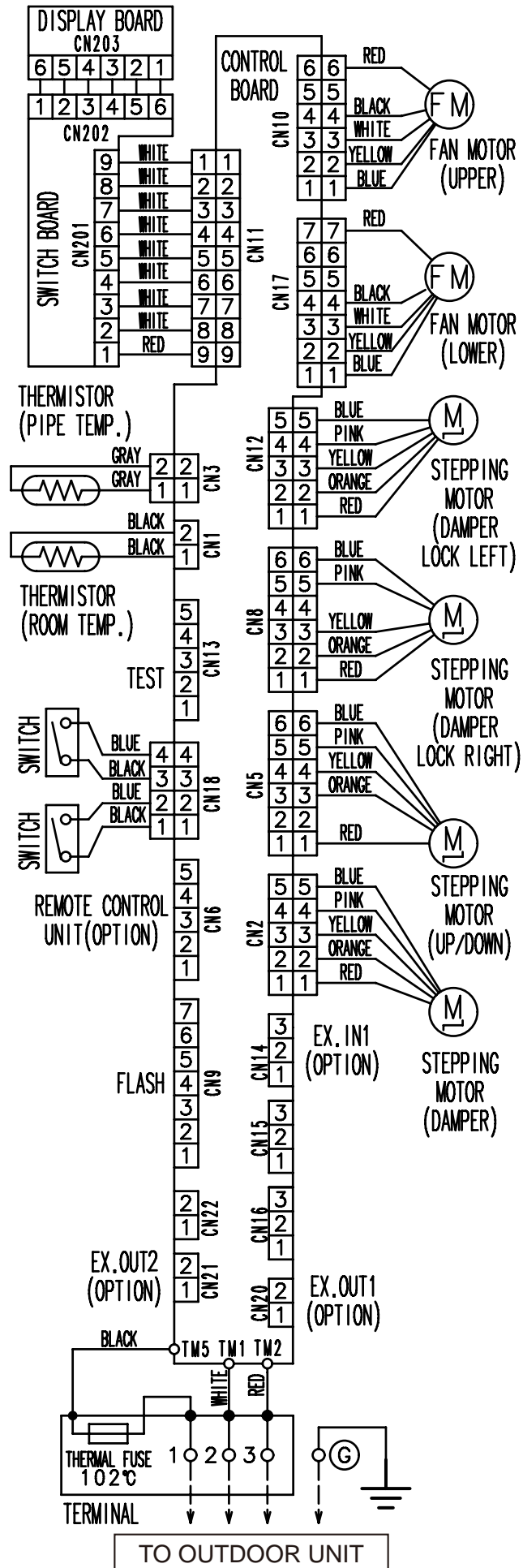

# 6. CAPACITY TABLE

## 6-1. COOLING CAPACITY

### MODEL: AGU9RLF

AFR	336
-----	-----

		Indoor temperature																				
		°FDB			64			70			75			80			85			90		
		°FWB			54			60			63			67			71			73		
Outdoor temperature	°FDB	TC	SHC	IP	TC	SHC	IP	TC	SHC	IP	TC	SHC	IP	TC	SHC	IP	TC	SHC	IP			
	67	6.88	6.10	0.26	7.77	6.09	0.27	8.20	6.72	0.27	8.78	7.05	0.27	9.38	7.21	0.28	9.67	8.02	0.28			
	77	7.79	6.88	0.44	8.80	6.87	0.45	9.28	7.58	0.45	9.93	7.95	0.45	10.62	8.14	0.46	10.95	9.04	0.46			
	87	7.36	6.49	0.49	8.32	6.48	0.50	8.77	7.15	0.51	9.39	7.50	0.51	10.04	7.67	0.52	10.35	8.53	0.52			
	95	7.06	6.23	0.54	7.97	6.22	0.55	8.41	6.86	0.55	9.00	7.20	0.56	9.62	7.37	0.57	9.92	8.19	0.57			
	104	6.54	5.77	0.56	7.39	5.76	0.57	7.79	6.35	0.57	8.34	6.67	0.58	8.92	6.82	0.59	9.19	7.58	0.59			
	115	6.43	5.69	0.57	7.27	5.68	0.58	7.66	6.26	0.59	8.20	6.57	0.59	8.77	6.73	0.60	9.04	7.48	0.60			

AFR : Air Flow Rate (CFM)  
 TC : Total Capacity (kBtu/h)  
 SHC : Sensible Heat Capacity (kBtu/h)  
 IP : Input Power (kW)

AFR	9.5
-----	-----

		Indoor temperature																				
		°CDB			17.8			21.1			23.9			26.7			29.4			32.2		
		°CWB			12.2			15.6			17.7			19.4			21.7			22.8		
Outdoor temperature	°CDB	TC	SHC	IP	TC	SHC	IP	TC	SHC	IP	TC	SHC	IP	TC	SHC	IP	TC	SHC	IP			
	19.4	2.02	1.79	0.26	2.28	1.79	0.27	2.40	1.97	0.27	2.57	2.07	0.27	2.75	2.11	0.28	2.83	2.35	0.28			
	25.0	2.28	2.02	0.44	2.58	2.01	0.45	2.72	2.22	0.45	2.91	2.33	0.45	3.11	2.38	0.46	3.21	2.65	0.46			
	30.6	2.16	1.90	0.49	2.44	1.90	0.50	2.57	2.09	0.51	2.75	2.20	0.51	2.94	2.25	0.52	3.03	2.50	0.52			
	35.0	2.07	1.83	0.54	2.34	1.82	0.55	2.46	2.01	0.55	2.64	2.11	0.56	2.82	2.16	0.57	2.91	2.40	0.57			
	40.0	1.92	1.69	0.56	2.17	1.69	0.57	2.28	1.86	0.57	2.44	1.95	0.58	2.61	2.00	0.59	2.69	2.22	0.59			
	46.0	1.89	1.67	0.57	2.13	1.66	0.58	2.25	1.84	0.59	2.40	1.93	0.59	2.57	1.97	0.60	2.65	2.19	0.60			

AFR : Air Flow Rate (m³/min)  
 TC : Total Capacity (kW)  
 SHC : Sensible Heat Capacity (kW)  
 IP : Input Power (kW)

### MODEL: AGU12RLF

AFR	336
-----	-----

		Indoor temperature																				
		°FDB			64			70			75			80			85			90		
		°FWB			54			60			63			67			71			73		
Outdoor temperature	°FDB	TC	SHC	IP	TC	SHC	IP	TC	SHC	IP	TC	SHC	IP	TC	SHC	IP	TC	SHC	IP			
	67	9.18	7.71	0.42	10.37	7.70	0.43	10.93	8.50	0.44	11.70	8.91	0.44	12.51	9.12	0.45	12.90	10.14	0.45			
	77	10.40	8.70	0.71	11.76	8.69	0.72	12.39	9.58	0.73	13.27	10.06	0.74	14.18	10.29	0.74	14.62	11.44	0.75			
	87	9.82	8.23	0.80	11.10	8.22	0.82	11.70	9.07	0.82	12.52	9.52	0.83	13.39	9.74	0.84	13.80	10.82	0.85			
	95	9.41	7.87	0.88	10.63	7.86	0.89	11.21	8.67	0.90	12.00	9.10	0.91	12.83	9.31	0.92	13.22	10.35	0.93			
	104	8.74	7.31	0.91	9.87	7.30	0.93	10.41	8.05	0.94	11.14	8.45	0.95	11.91	8.65	0.96	12.28	9.61	0.96			
	115	8.57	7.19	0.92	9.69	7.18	0.94	10.22	7.92	0.95	10.94	8.31	0.96	11.69	8.51	0.97	12.05	9.45	0.97			

AFR : Air Flow Rate (CFM)  
 TC : Total Capacity (kBtu/h)  
 SHC : Sensible Heat Capacity (kBtu/h)  
 IP : Input Power (kW)

AFR	9.5
-----	-----

		Indoor temperature																				
		°CDB			17.8			21.1			23.9			26.7			29.4			32.2		
		°CWB			12.2			15.6			17.7			19.4			21.7			22.8		
Outdoor temperature	°CDB	TC	SHC	IP	TC	SHC	IP	TC	SHC	IP	TC	SHC	IP	TC	SHC	IP	TC	SHC	IP			
	19.4	2.69	2.26	0.42	3.04	2.26	0.43	3.20	2.49	0.44	3.43	2.61	0.44	3.67	2.67	0.45	3.78	2.97	0.45			
	25.0	3.05	2.55	0.71	3.45	2.55	0.72	3.63	2.81	0.73	3.89	2.95	0.74	4.16	3.02	0.74	4.29	3.35	0.75			
	30.6	2.88	2.41	0.80	3.25	2.41	0.82	3.43	2.66	0.82	3.67	2.79	0.83	3.92	2.85	0.84	4.05	3.17	0.85			
	35.0	2.76	2.31	0.88	3.12	2.30	0.89	3.28	2.54	0.90	3.52	2.67	0.91	3.76	2.73	0.92	3.88	3.03	0.93			
	40.0	2.56	2.14	0.91	2.89	2.14	0.93	3.05	2.36	0.94	3.27	2.48	0.95	3.49	2.53	0.96	3.60	2.82	0.96			
	46.0	2.51	2.11	0.92	2.84	2.10	0.94	2.99	2.32	0.95	3.21	2.44	0.96	3.43	2.49	0.97	3.53	2.77	0.97			

AFR : Air Flow Rate (m³/min)  
 TC : Total Capacity (kW)  
 SHC : Sensible Heat Capacity (kW)  
 IP : Input Power (kW)

# MODEL: AGU15RLF

AFR	383
-----	-----

		Indoor temperature																				
		°FDB			64			70			75			80			85			90		
		°FWB			54			60			63			67			71			73		
Outdoor temperature	°FDB	TC	SHC	IP	TC	SHC	IP	TC	SHC	IP	TC	SHC	IP	TC	SHC	IP	TC	SHC	IP			
	67	11.59	9.12	0.61	13.10	9.11	0.62	13.81	10.05	0.62	14.79	10.54	0.63	15.81	10.78	0.64	16.29	11.99	0.64			
	77	12.30	9.64	0.90	13.90	9.63	0.91	14.65	10.62	0.92	15.69	11.14	0.93	16.77	11.40	0.94	17.29	12.67	0.95			
	87	11.63	9.11	1.00	13.14	9.10	1.02	13.85	10.04	1.03	14.83	10.53	1.04	15.85	10.78	1.05	16.34	11.98	1.06			
	95	11.13	8.74	1.09	12.58	8.73	1.11	13.26	9.62	1.12	14.20	10.10	1.13	15.18	10.33	1.14	15.65	11.48	1.15			
	104	9.89	7.75	1.14	11.17	7.74	1.16	11.78	8.53	1.17	12.61	8.96	1.18	13.48	9.16	1.19	13.90	10.18	1.20			
	115	9.33	7.31	1.15	10.54	7.30	1.17	11.12	8.05	1.18	11.90	8.45	1.19	12.72	8.65	1.20	13.11	9.61	1.21			

AFR : Air Flow Rate (CFM)  
 TC : Total Capacity (kBtu/h)  
 SHC : Sensible Heat Capacity (kBtu/h)  
 IP : Input Power (kW)

AFR	10.8
-----	------

		Indoor temperature																				
		°CDB			17.8			21.1			23.9			26.7			29.4			32.2		
		°CWB			12.2			15.6			17.7			19.4			21.7			22.8		
Outdoor temperature	°CDB	TC	SHC	IP	TC	SHC	IP	TC	SHC	IP	TC	SHC	IP	TC	SHC	IP	TC	SHC	IP			
	19.4	3.40	2.67	0.61	3.84	2.67	0.62	4.05	2.94	0.62	4.33	3.09	0.63	4.63	3.16	0.64	4.78	3.51	0.64			
	25.0	3.60	2.83	0.90	4.07	2.82	0.91	4.29	3.11	0.92	4.60	3.27	0.93	4.92	3.34	0.94	5.07	3.71	0.95			
	30.6	3.41	2.67	1.00	3.85	2.67	1.02	4.06	2.94	1.03	4.35	3.09	1.04	4.65	3.16	1.05	4.79	3.51	1.06			
	35.0	3.26	2.56	1.09	3.69	2.56	1.11	3.89	2.82	1.12	4.16	2.96	1.13	4.45	3.03	1.14	4.59	3.37	1.15			
	40.0	2.90	2.27	1.14	3.27	2.27	1.16	3.45	2.50	1.17	3.70	2.62	1.18	3.95	2.69	1.19	4.07	2.98	1.20			
	46.0	2.73	2.14	1.15	3.09	2.14	1.17	3.26	2.36	1.18	3.49	2.48	1.19	3.73	2.53	1.20	3.84	2.82	1.21			

AFR : Air Flow Rate (m<sup>3</sup>/min)  
 TC : Total Capacity (kW)  
 SHC : Sensible Heat Capacity (kW)  
 IP : Input Power (kW)

# 6-2. HEATING CAPACITY

This table is created using the maximum capacity.

## MODEL: AGU9RLF

AFR	353
-----	-----

		Indoor temperature								
		°FDB		60		65		70		75
Outdoor temperature	°FDB	°FWB	TC	IP	TC	IP	TC	IP	TC	IP
	-5	-7	7.15	0.86	6.92	0.88	6.69	0.91	6.45	0.94
	5	3	8.93	0.98	8.65	1.01	8.36	1.04	8.06	1.07
	14	12	11.21	1.12	10.86	1.16	10.49	1.19	10.12	1.22
	23	19	13.40	1.28	12.97	1.32	12.54	1.36	12.10	1.39
	32	28	15.48	1.46	14.99	1.50	14.48	1.55	13.97	1.59
	41	37	18.46	1.83	17.88	1.89	17.28	1.94	16.67	1.99
	47	43	17.83	1.73	17.26	1.78	16.68	1.83	16.10	1.88
	50	47	20.49	1.75	19.84	1.80	19.17	1.85	18.50	1.90
	59	50	20.49	1.65	19.84	1.70	19.17	1.75	18.50	1.80

AFR : Air Flow Rate (CFM)  
TC : Total Capacity (kBtu/h)  
IP : Input Power (kW)

AFR	10.0
-----	------

		Indoor temperature								
		°CDB		15.6		18.3		21.1		23.9
Outdoor temperature	°CDB	°CWB	TC	IP	TC	IP	TC	IP	TC	IP
	-20.6	-21.7	2.09	0.86	2.03	0.88	1.96	0.91	1.89	0.94
	-15.0	-16.1	2.62	0.98	2.54	1.01	2.45	1.04	2.36	1.07
	-10.0	-11.1	3.29	1.12	3.18	1.16	3.07	1.19	2.97	1.22
	-5.0	-7.2	3.93	1.28	3.80	1.32	3.67	1.36	3.55	1.39
	0.0	-2.2	4.54	1.46	4.39	1.50	4.24	1.55	4.10	1.59
	5.0	2.8	5.41	1.83	5.24	1.89	5.06	1.94	4.89	1.99
	8.3	6.1	5.22	1.73	5.06	1.78	4.89	1.83	4.72	1.88
	10.0	8.3	6.00	1.75	5.82	1.80	5.62	1.85	5.42	1.90
	15.0	10.0	6.00	1.65	5.82	1.70	5.62	1.75	5.42	1.80

AFR : Air Flow Rate (m³/min)  
TC : Total Capacity (kW)  
IP : Input Power (kW)

## MODEL: AGU12RLF

AFR	353
-----	-----

		Indoor temperature								
		°FDB		60		65		70		75
Outdoor temperature	°FDB	°FWB	TC	IP	TC	IP	TC	IP	TC	IP
	-5	-7	9.92	1.29	9.60	1.32	9.28	1.36	8.95	1.40
	5	3	11.45	1.39	11.09	1.43	10.71	1.48	10.34	1.52
	14	12	13.42	1.51	12.99	1.56	12.55	1.60	12.12	1.64
	23	19	15.33	1.64	14.85	1.69	14.35	1.74	13.84	1.78
	32	28	17.14	1.79	16.60	1.84	16.03	1.89	15.47	1.94
	41	37	19.74	2.00	19.12	2.06	18.47	2.12	17.83	2.18
	47	43	19.09	1.89	18.49	1.94	17.86	2.00	17.23	2.06
	50	47	21.93	1.91	21.24	1.96	20.52	2.02	19.80	2.08
	59	50	21.93	1.80	21.24	1.86	20.52	1.91	19.80	1.96

AFR : Air Flow Rate (CFM)  
TC : Total Capacity (kBtu/h)  
IP : Input Power (kW)

AFR	10.0
-----	------

		Indoor temperature								
		°CDB		15.6		18.3		21.1		23.9
Outdoor temperature	°CDB	°CWB	TC	IP	TC	IP	TC	IP	TC	IP
	-20.6	-21.7	2.91	1.29	2.81	1.32	2.72	1.36	2.62	1.40
	-15.0	-16.1	3.36	1.39	3.25	1.43	3.14	1.48	3.03	1.52
	-10.0	-11.1	3.93	1.51	3.81	1.56	3.68	1.60	3.55	1.64
	-5.0	-7.2	4.49	1.64	4.35	1.69	4.20	1.74	4.06	1.78
	0.0	-2.2	5.02	1.79	4.86	1.84	4.70	1.89	4.54	1.94
	5.0	2.8	5.79	2.00	5.60	2.06	5.41	2.12	5.22	2.18
	8.3	6.1	5.59	1.89	5.42	1.94	5.23	2.00	5.05	2.06
	10.0	8.3	6.43	1.91	6.22	1.96	6.01	2.02	5.80	2.08
	15.0	10.0	6.43	1.80	6.22	1.86	6.01	1.91	5.80	1.96

AFR : Air Flow Rate (m³/min)  
TC : Total Capacity (kW)  
IP : Input Power (kW)

# MODEL: AGU15RLF

AFR	383
-----	-----

		Indoor temperature									
		°FDB		60		65		70		75	
Outdoor temperature	°FDB	°FWB	TC	IP	TC	IP	TC	IP	TC	IP	
	-5	-7	11.89	1.74	11.51	1.79	11.12	1.84	10.73	1.90	
	5	3	14.44	1.97	13.98	2.03	13.51	2.08	13.04	2.14	
	14	12	17.17	2.20	16.63	2.26	16.07	2.33	15.51	2.39	
	23	19	19.62	2.45	19.00	2.52	18.35	2.59	17.71	2.66	
	32	28	22.08	2.71	21.38	2.79	20.66	2.87	19.93	2.95	
	41	37	22.59	2.43	21.87	2.50	20.80	2.53	19.53	2.53	
	47	43	22.68	2.19	21.96	2.26	21.22	2.32	20.48	2.38	
	50	47	21.35	2.21	20.67	2.27	19.97	2.34	19.28	2.41	
	59	50	22.51	1.85	21.80	1.90	21.07	1.95	20.33	2.01	

AFR : Air Flow Rate (CFM)  
TC : Total Capacity (kBtu/h)  
IP : Input Power (kW)

AFR	10.8
-----	------

		Indoor temperature									
		°CDB		16		18		20		24	
Outdoor temperature	°CDB	°CWB	TC	IP	TC	IP	TC	IP	TC	IP	
	-20.6	-21.7	3.48	1.74	3.37	1.79	3.26	1.84	3.15	1.90	
	-15.0	-16.1	4.23	1.97	4.10	2.03	3.96	2.08	3.82	2.14	
	-10.0	-11.1	5.03	2.20	4.87	2.26	4.71	2.33	4.54	2.39	
	-5.0	-7.2	5.75	2.45	5.57	2.52	5.38	2.59	5.19	2.66	
	0.0	-2.2	6.47	2.71	6.27	2.79	6.05	2.87	5.84	2.95	
	5.0	2.8	6.52	2.43	6.31	2.50	6.10	2.53	5.88	2.53	
	8.3	6.1	6.65	2.19	6.44	2.26	6.22	2.32	6.00	2.38	
	10.0	8.3	6.26	2.21	6.06	2.27	5.85	2.34	5.65	2.41	
	15.0	10.0	6.60	1.85	6.39	1.90	6.17	1.95	5.96	2.01	

AFR : Air Flow Rate (m<sup>3</sup>/min)  
TC : Total Capacity (kW)  
IP : Input Power (kW)

# 7. FAN PERFORMANCE AND CAPACITY

## 7-1. AIR VELOCITY DISTRIBUTION

### ■ MODEL: AGU9RLF, AGU12RLF, AGU15RLF

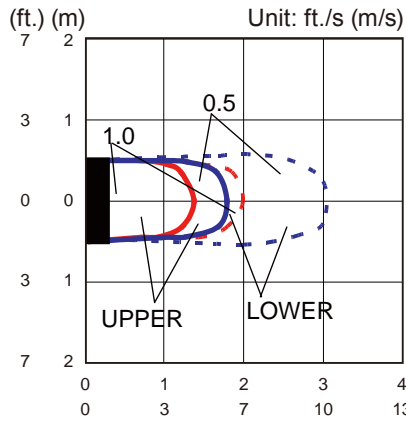

Top view  
Vertical airflow direction louver: Up  
Horizontal airflow direction louver: Center

Conditions:  
Fan speed: HIGH  
Operation mode: FAN  
Fan select: UPPER & LOWER  
—— : UPPER FAN  
- - - - : LOWER FAN

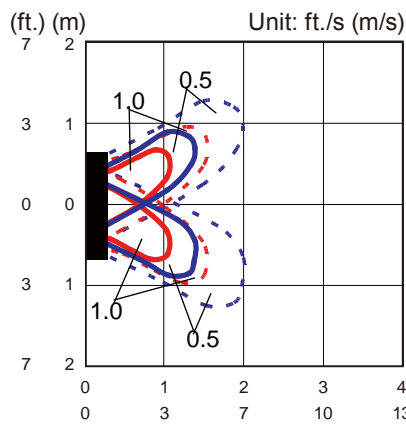

Top view  
Vertical airflow direction louver: Up  
Horizontal airflow direction louver: Right & Left

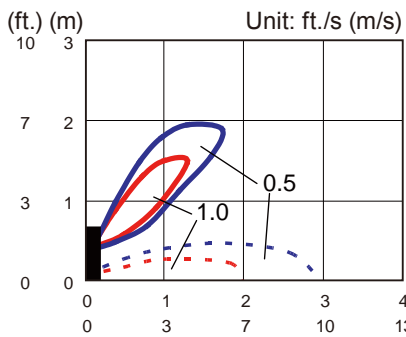

Top view  
Vertical airflow direction louver: Up  
Horizontal airflow direction louver: Center

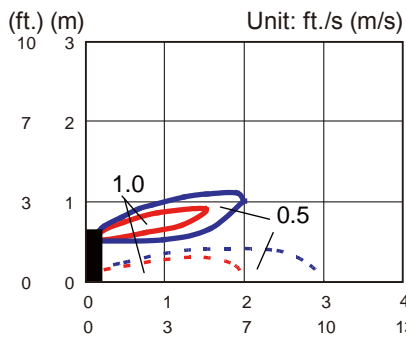

Top view  
Vertical airflow direction louver: Down  
Horizontal airflow direction louver: Center



## 7-2. AIRFLOW

### ■ MODEL: AGU9RLF, AGU12RLF

#### ● Cooling

Fan speed	Number of rotations [r.p.m] (UPPER/LOWER)	Airflow	
		m <sup>3</sup> /h	l/s
HIGH	1190/1000	m <sup>3</sup> /h	570
		l/s	158
		CFM	336
MED	1000/850	m <sup>3</sup> /h	460
		l/s	128
		CFM	271
LOW	820/690	m <sup>3</sup> /h	360
		l/s	100
		CFM	212
QUIET	660/560	m <sup>3</sup> /h	270
		l/s	75
		CFM	159

#### ● Heating

Fan speed	Number of rotations [r.p.m] (UPPER/LOWER)	Airflow	
		m <sup>3</sup> /h	l/s
HIGH	1240/1040	m <sup>3</sup> /h	600
		l/s	167
		CFM	353
MED	1040/880	m <sup>3</sup> /h	480
		l/s	133
		CFM	283
LOW	840/700	m <sup>3</sup> /h	370
		l/s	103
		CFM	218
QUIET	660/560	m <sup>3</sup> /h	270
		l/s	75
		CFM	159

## ■ MODEL: AGU15RLF

### ● Cooling

Fan speed	Number of rotations [r.p.m] (UPPER/LOWER)	Airflow	
HIGH	1330/1120	m <sup>3</sup> /h	650
		l/s	181
		CFM	383
MED	1100/930	m <sup>3</sup> /h	520
		l/s	144
		CFM	306
LOW	890/750	m <sup>3</sup> /h	400
		l/s	111
		CFM	235
QUIET	660/560	m <sup>3</sup> /h	270
		l/s	75
		CFM	159

### ● Heating

Fan speed	Number of rotations [r.p.m] (UPPER/LOWER)	Airflow	
HIGH	1330/1120	m <sup>3</sup> /h	650
		l/s	181
		CFM	383
MED	1100/930	m <sup>3</sup> /h	520
		l/s	144
		CFM	306
LOW	860/730	m <sup>3</sup> /h	390
		l/s	108
		CFM	230
QUIET	660/560	m <sup>3</sup> /h	270
		l/s	75
		CFM	159

# 8. OPERATION NOISE (SOUND PRESSURE)

## 8-1. NOISE LEVEL CURVE

### MODEL: AGU9RLF

#### ● Cooling

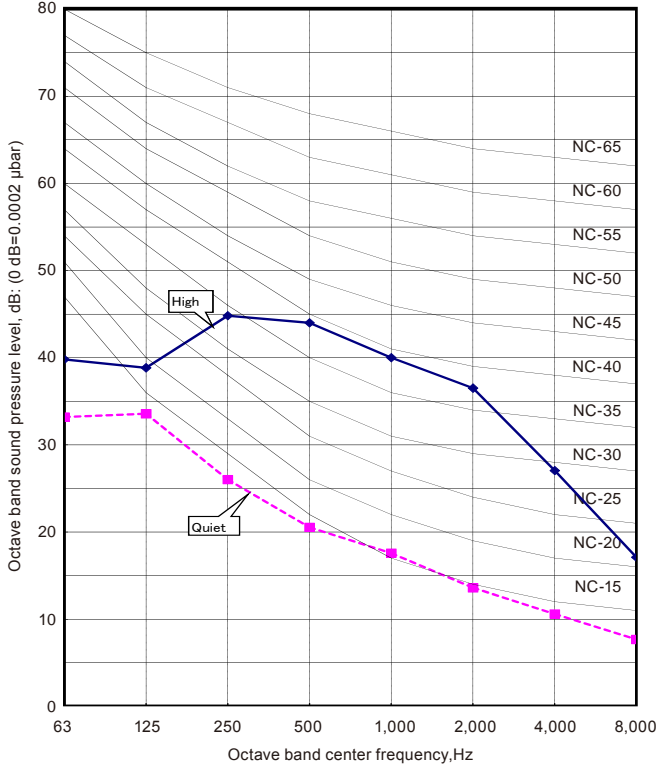

#### ● Heating

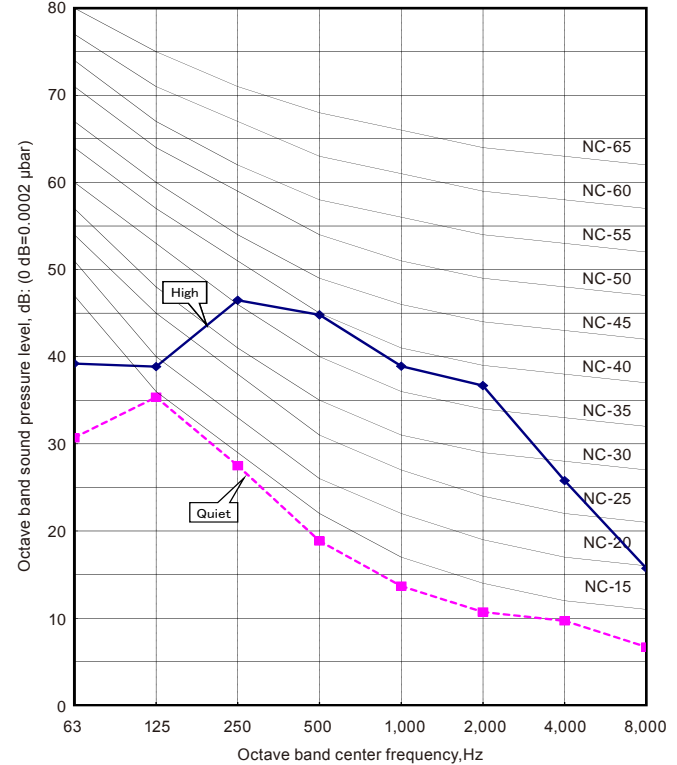

### MODEL: AGU12RLF

#### ● Cooling

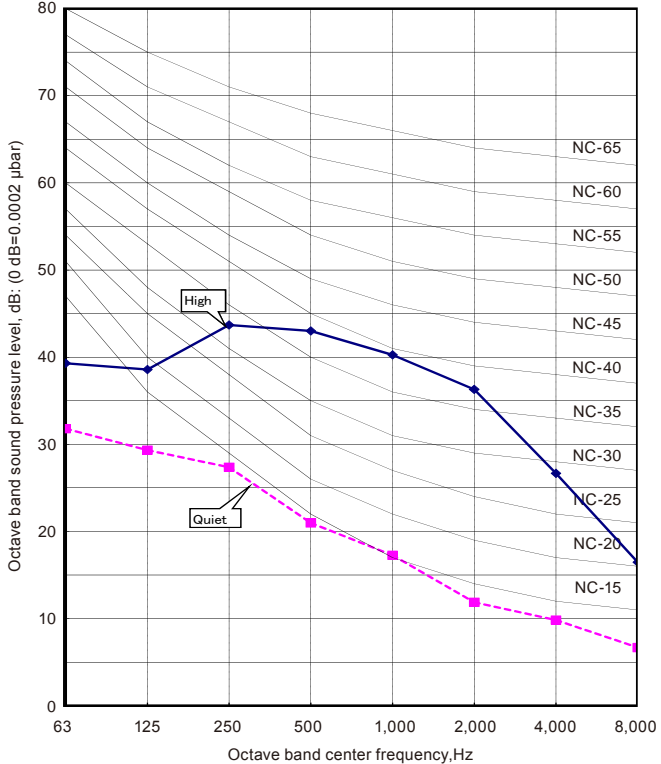

#### ● Heating

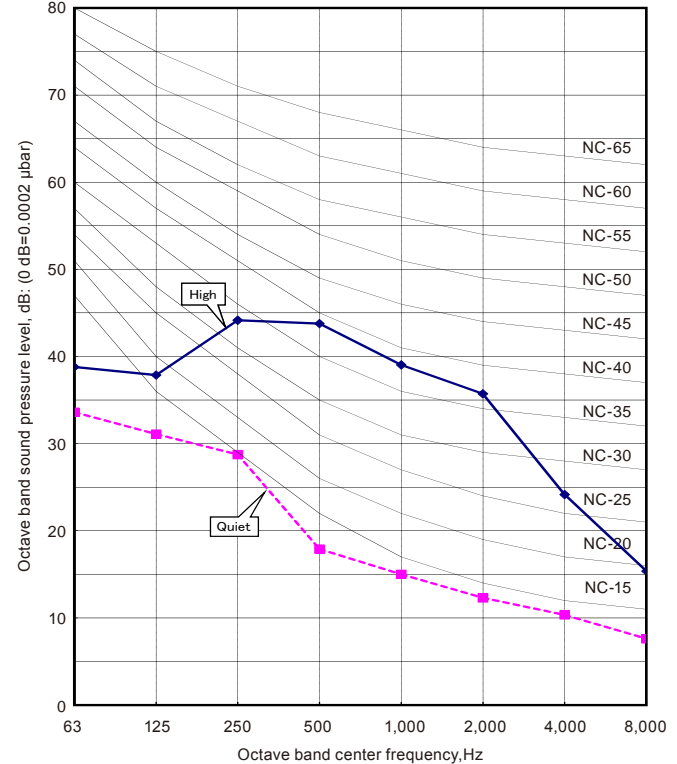

# MODEL: AGU15RLF

## ● Cooling

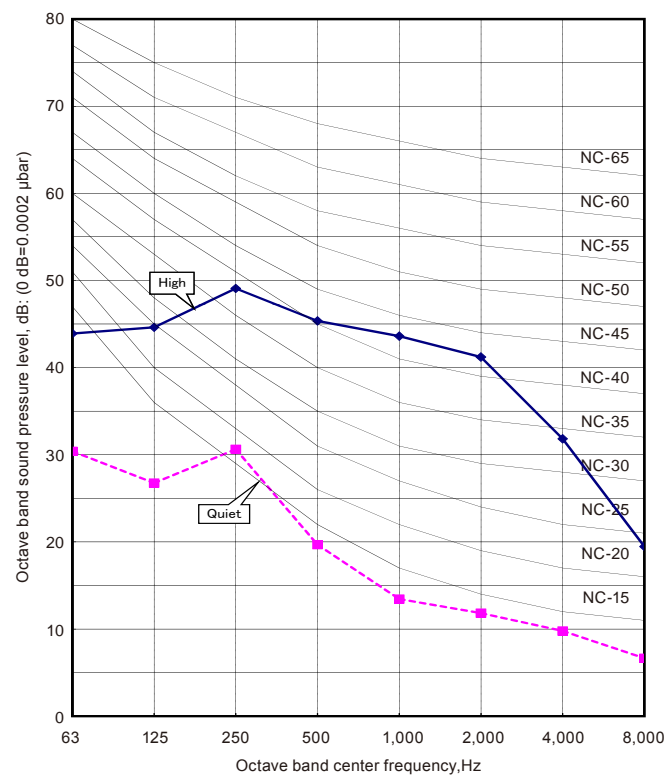

## ● Heating

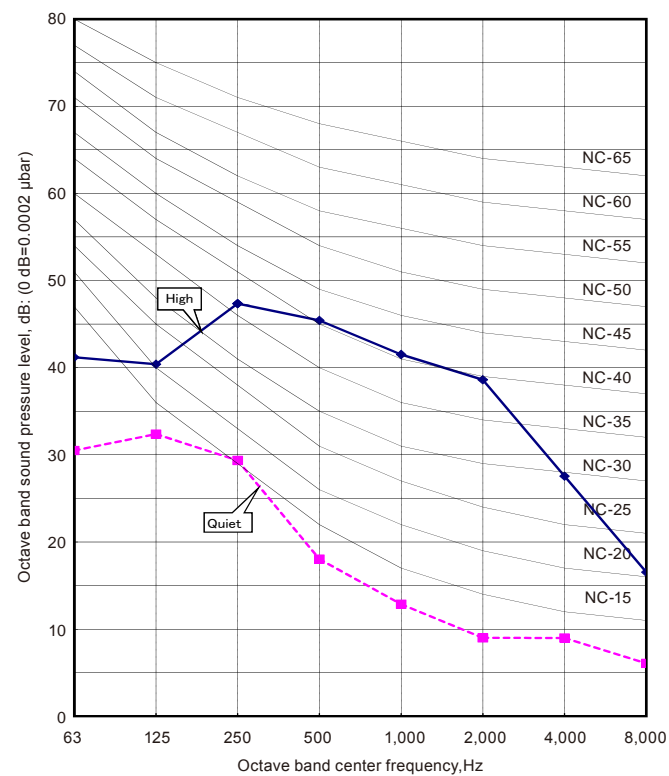

## 8-2. SOUND LEVEL CHECK POINT

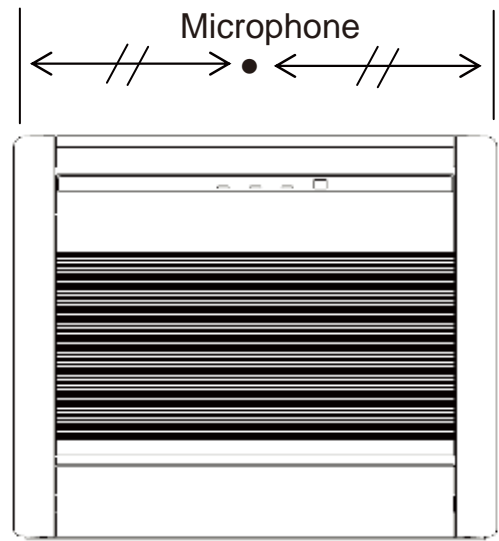
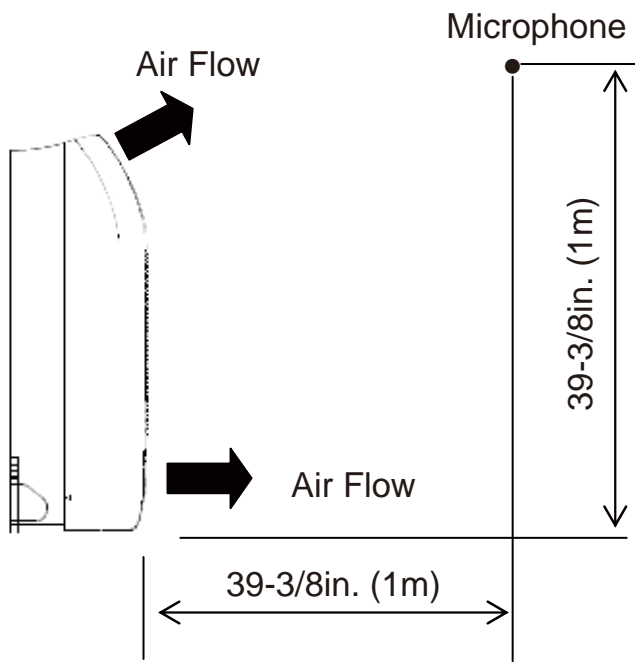

## 9. ELECTRIC CHARACTERISTICS

Model Name			AGU9RLF	AGU12RLF	AGU15RLF
Power Supply	Voltage	V	208 / 230 ~		
	Frequency	Hz	60		
Max Operating Current		A	0.7		
*)Wiring Spec	Connection Cable	AWG	14		
	Limited wiring length	ft. (m)	69 (21)		

\*) Wiring Spec  
Selected Sample  
(Selected based on Japan Electrotechnical Standard and Codes Committee E0005)

## 10. SAFETY DEVICES

	Protection form	Model		
		AGU9RLF	AGU12RLF	AGU15RLF
Circuit protection	Current fuse (PCB)	250V 3.15A		
Terminal protection	Current (thermal) fuse	250V 3A		
Fan motor protection	Terminal protection program	OFF: 302 ± 27 °F (150 ± 15 °C) ON: 248 ± 27 °F (120 ± 15 °C)		

# 11. EXTERNAL INPUT & OUTPUT

Connector	INPUT	OUTPUT	REMARKS
CN14	Control input	-	See external input/output settings for details.
CN20	-	Operation status output	
CN21	-	Error status output	

## 11-1. EXTERNAL INPUT

### ■ CONTROL INPUT (Operation/Stop or Forced stop)

The air conditioner can be remotely operated by means of the following on-site work.

"Operation/Stop" mode or "Forced stop" mode can be selected with function setting of indoor unit.

Unit operation is started at the following contents by adding the contact input of a commercial ON/OFF switch to a connector on the external control PC board and turning it ON.

Unit operation	Initial setting after power is ON	Starting mode other than initial setting
Operation mode	Auto changeover	Mode at previous operation
Set temperature	76°F (24°C)	Temperature at previous operation
Airflow mode	AUTO	Mode at previous operation
Up-down air direction (swing)	Standard air direction (swing OFF)	Air direction at previous operation
Left-right air direction (swing)	Standard air direction (swing OFF)	Air direction at previous operation

### ● Circuit diagram example

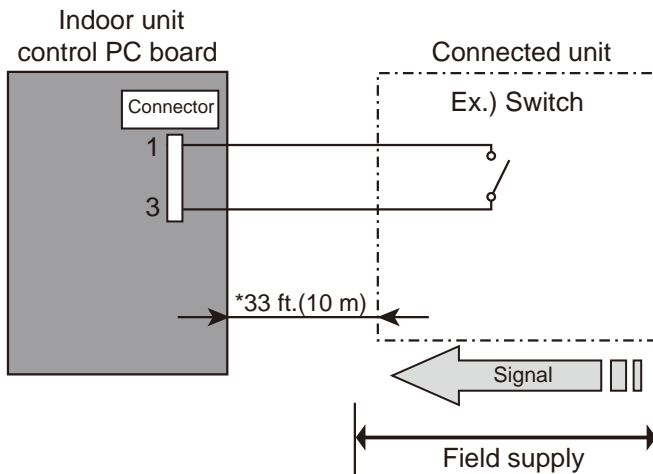

\*: Make the distance from the PC board to the connected unit within 33 ft.(10 m).  
Contact capacity: DC 24 V or more, 10 mA or more.

#### ● When function setting is in "Operation/Stop" mode

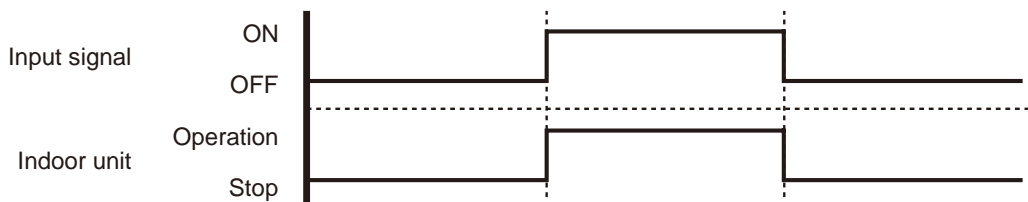

#### ● When function setting is "Forced stop" mode

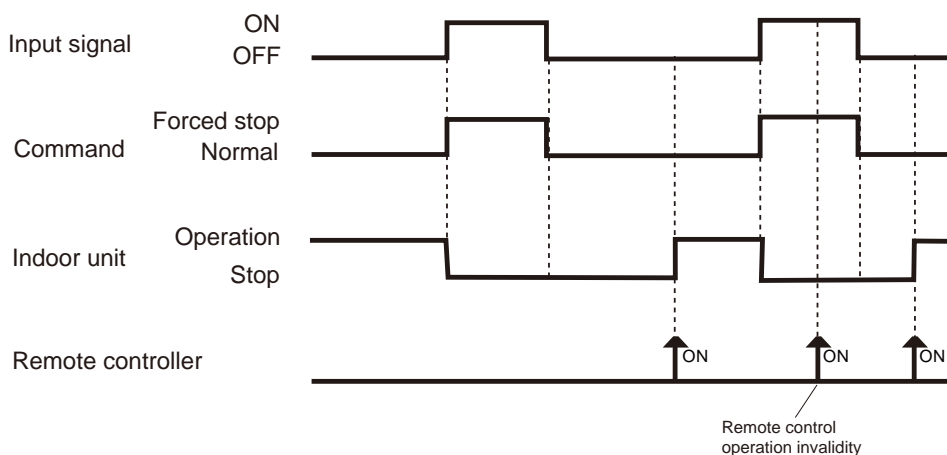



**● Parts (Optional)**

Parts name	Model name
External connect kit	UTY-XWZXZ5

Wire (External input) : UTY-XWZXZ5



## 11-2. EXTERNAL OUTPUT

### ■ OPERATION STATUS OUTPUT

An air conditioner operation status signal can be output.

#### ● Circuit diagram example

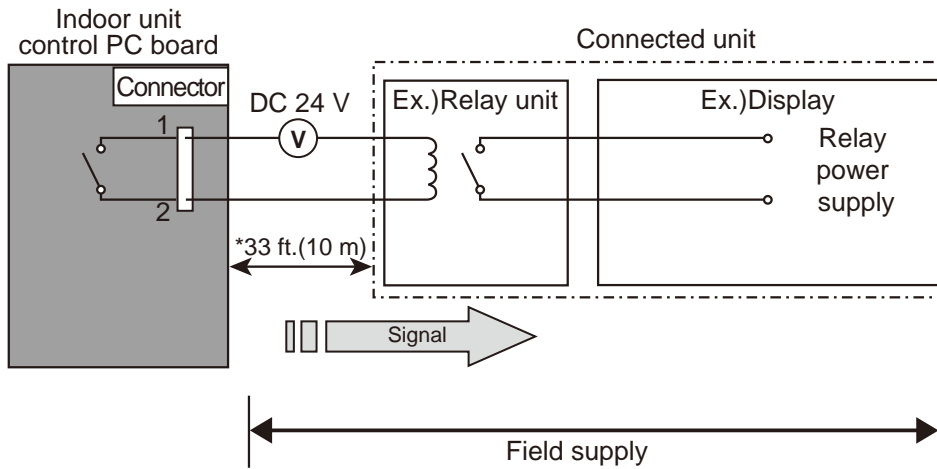

\*: Make the distance from the PC board to the connected unit within 33 ft.(10 m).  
Relay spec.: Max. DC 24 V, 10 mA to less than 500 mA.

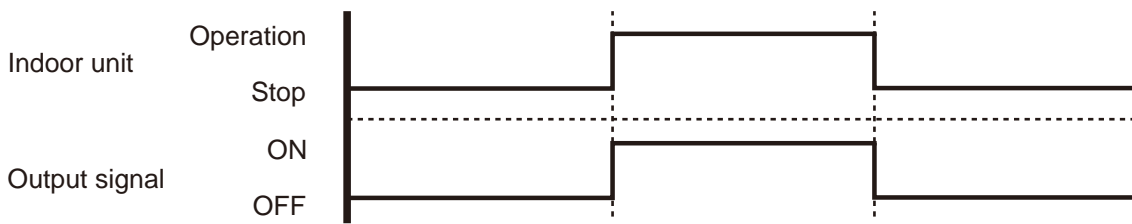

#### ● Parts (Optional)

Parts name	Model name
External connect kit	UTY-XWZXZ5

Wire (External output) : UTY-XWZXZ5



## ■ ERROR STATUS OUTPUT

An air conditioner error status signal can be output.

### ● Circuit diagram example

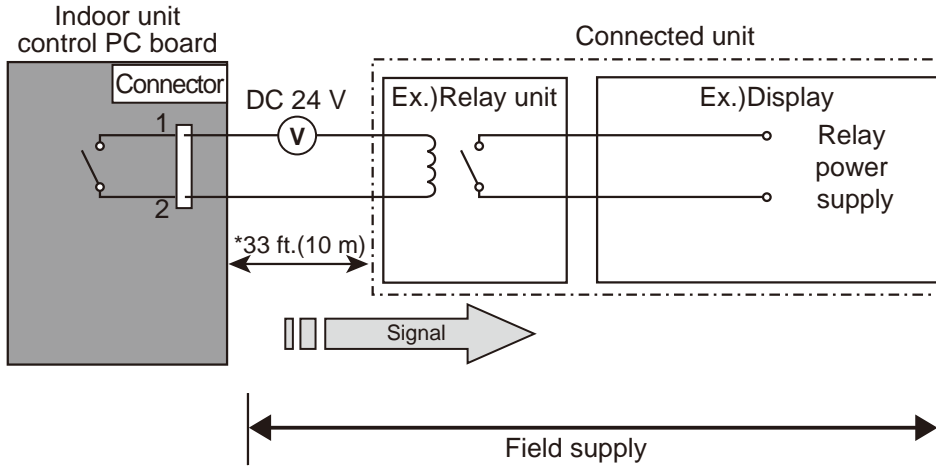

\*: Make the distance from the PC board to the connected unit within 33 ft.(10 m).  
Relay spec.: Max. DC 24 V, 10 mA to less than 500 mA.

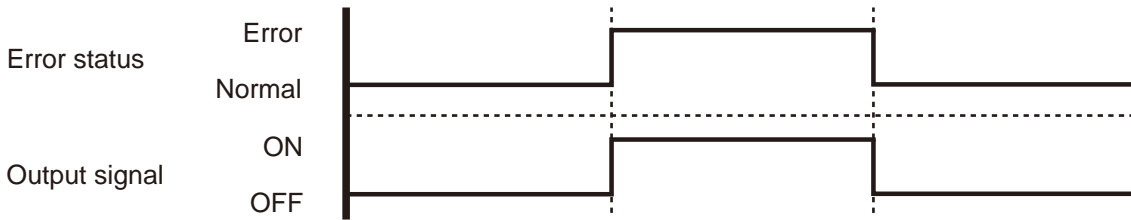

### ● Parts (Optional)

Parts name	Model name
External connect kit	UTY-XWZXZ5

Wire (External output) : UTY-XWZXZ5



## 12. FUNCTION SETTINGS

### 12-1. INDOOR UNIT (Setting by remote controller)

- The function settings of the control of the indoor unit can be changed by this procedure according to the installation conditions. Incorrect settings can cause the indoor unit to malfunction.
- After the power is turned on, perform the Function Setting according to the installation conditions using the remote controller.
- The settings may be selected between the following two: Function Number and Setting Value.
- Settings will not be changed if invalid numbers or setting values are selected.

#### ■ PREPARATION

- Before turning on the power of the indoor unit:
  - Confirm whether the piping air-tight test and vacuuming have been conducted.
  - Reconfirm whether there is no miswiring.
- Turn on the power of the indoor units.

#### ■ FUNCTION SETTING METHOD (for Wireless remote controller)

##### Entering the Function Setting Mode

- While pressing the POWERFUL button and SET TEMP. (Λ) simultaneously, press the RESET button to enter the function setting mode.

##### STEP 1

##### Setting the Remote controller Custom Code

Use the following steps to select the custom code of the remote controller. (Note that the air conditioner cannot receive a custom code if the air conditioner has not been set for the custom code.) The custom codes that are set through this process are applicable only during the Function Setting process. For details on how to set the custom codes through the normal process, refer to "REMOTE CONTROLLER CUSTOM CODE SETTING".

1. Press the SET TEMP. (Λ) (V) button to change the custom code between  $\bar{a}$  →  $\bar{b}$  →  $\bar{c}$  →  $\bar{d}$ .  
Match the code on the display to the air conditioner custom code. (initially set to  $\bar{a}$ )  
(If the custom code does not need to be selected, press the MIN. HEAT button and proceed to **STEP 2**.)
2. Press the MODE button and check that the indoor unit can receive signals at the displayed custom code.
3. Press the MIN. HEAT button to accept the custom code, and proceed to **STEP 2**.

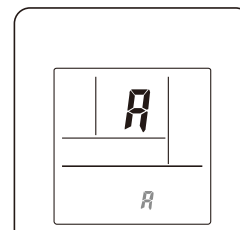

The air conditioner custom code is set to "A" prior to shipment.

The remote controller resets to custom code A when the batteries in the remote controller are replaced. If you use a custom code other than custom code A, reset the custom code after replacing the batteries.  
If you do not know the air conditioner custom code setting, try each of the custom codes ( $\bar{a}$  →  $\bar{b}$  →  $\bar{c}$  →  $\bar{d}$ ) until you find the code which operates the air conditioner.

##### STEP 2

##### Selecting the Function Number and Setting Value

1. Press the SET TEMP. (Λ) (V) buttons to select the function number.  
(Press the MIN. HEAT button to switch between the left and right digits.)
2. Press the POWERFUL button to proceed to setting the value.  
(Press the POWERFUL button again to return to the function number selection.)
3. Press the SET TEMP. (Λ) (V) buttons to select the setting value.  
(Press the MIN. HEAT button to switch between the left and right digits.)
4. Press the MODE button, then the START/STOP button in order to fix the settings.
5. Press the RESET button to end the function setting mode.
6. After completing the Function Setting, be sure to turn off the power and turn it on again.

##### Function number

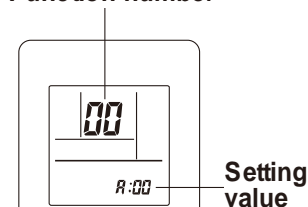

#### ⚠ CAUTION

After turning off the power, wait 30 seconds or more before turning it on again.  
The Function Setting will not become active unless the power is turned off then on again.

## FUNCTION DETAILS

Functions	
1)	Filter sign
2)	Vertical airflow direction range control
3)	Room temperature control for cooling
4)	Room temperature control for heating
5)	Auto restart
6)	Room temperature sensor switching
7)	Remote controller custom code
8)	External input control
9)	Indoor unit fan control for energy saving for cooling

### 1) Filter sign

Select appropriate intervals for displaying the filter sign on the indoor unit according to the estimated amount of dust in the air of the room.

If the indication is not required, select "No indication" (03).

(◆... Factory setting)

Setting description	Function number	Setting value
Standard (400 hours)	11	00
Long interval (1000 hours)		01
Short interval (200 hours)		02
No indication		03

### 2) Vertical airflow direction range control

In a concealed installation, change the setting to "Fixed" (02) to restrict the movement of the upper air outlet so that the airflow is only towards the horizontal direction.

(◆... Factory setting)

Setting description	Function number	Setting value
Standard	23	00
(Setting prohibited)		01
Fixed (Concealed)		02

### 3) Room temperature control for cooling

Depending on the installed environment, correction of the room temperature sensor may be required.

Select the appropriate control setting according to the installed environment.

(◆... Factory setting)

Setting description	Function number	Setting value
Standard	30	00
Slightly lower control		01
Lower control		02
Higher control		03

#### 4) Room temperature control for heating

Depending on the installed environment, correction of the room temperature sensor may be required.

Select the appropriate control setting according to the installed environment.

(◆... Factory setting)

Setting description	Function number	Setting value
◆ Standard	31	00
Lower control		01
Slightly Higher control		02
Higher control		03

#### 5) Auto restart

Enable or disable automatic restart after a power interruption.

(◆... Factory setting)

Setting description	Function number	Setting value
◆ Enable	40	00
Disable		01

\*Auto restart is an emergency function such as for power outage etc.

Do not attempt to use this function in normal operation.

Be sure to operate the unit by remote controller or external input device.

#### 6) Room temperature sensor switching

(Only for wired remote controller)

When using the Wired remote controller temperature sensor, change the setting to "Both" (01).

(◆... Factory setting)

Setting description	Function number	Setting value
◆ Indoor unit	42	00
Both		01

00: Sensor on the indoor unit is active.

01: Sensors on both indoor unit and wired remote controller are active.

#### 7) Remote controller custom code

(Only for wireless remote controller)

The indoor unit custom code can be changed.

Select the appropriate custom code.

(◆... Factory setting)

Setting description	Function number	Setting value
◆ A	44	00
B		01
C		02
D		03

## 8) External input control

"Operation/Stop" mode or "Forced stop" mode can be selected.

(◆... Factory setting)

Setting description	Function number	Setting value
◆ Operation/Stop mode	46	00
(Setting prohibited)		01
Forced stop mode		02

## 9) Indoor unit fan control for energy saving for cooling

Enable or disable the power-saving function by controlling the indoor unit fan rotation when the outdoor unit is stopped during cooling operation.

(◆... Factory setting)

Setting description	Function number	Setting value
◆ Disable	49	00
Enable		01

00: When the outdoor unit is stopped, the indoor unit fan operates continuously following the setting on the remote controller.

01: When the outdoor unit is stopped, the indoor unit fan operates intermittently at a very low speed.

## ■ REMOTE CONTROLLER CUSTOM CODE SETTING

Use the following steps to select the custom code of the remote controller.

(Note that the air conditioner cannot receive a signal if the right custom code has not been set.)

1. Press the START/STOP button until only the clock is displayed on the remote controller display.
2. Press the MODE button for at least five seconds to display the current custom code (initially set to **A**).
3. Press the SET TEMP. (**∧**) (**∨**) button to change the custom code between **A** → **b** → **c** → **d**.  
Match the code on the display to the air conditioner custom code.
4. Press the MODE button again to return to the clock display. The custom code will be changed.

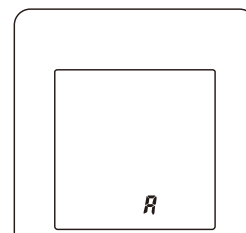

If no buttons are pressed within 30 seconds after the custom code is displayed, the system returns to the original clock display. In this case, start again from step 1.

The air conditioner custom code is set to A prior to shipment.

The remote controller resets to custom code A when the batteries in the remote controller are replaced. If you use a custom code other than custom code A, reset the custom code after replacing the batteries. If you do not know the air conditioner custom code setting, try each of the custom codes (**A** → **b** → **c** → **d**) until you find the code which operates the air conditioner.

## ■ REMOTE CONTROLLER TEMPERATURE UNIT

To change the temperature unit:

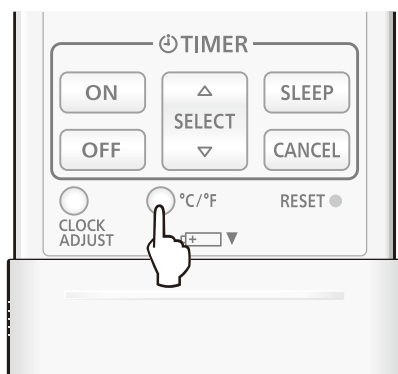

- Press the °C / °F switching button to select the preferred temperature unit. (Factory setting is °F.)



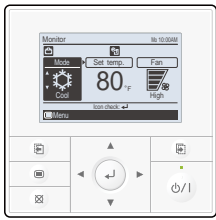
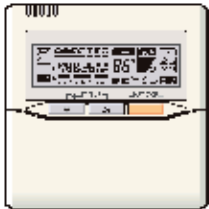

# 13. OPTIONAL PARTS

## 13-1. CONTROLLER

Exterior	Parts name	Model No.	Summary
	Wired remote controller	UTY-RVNUM	Large and full-dot liquid crystal screen, wide and large keys easy to press, user-intuitive arrow key.
	Wired remote controller	UTY-RNNUM	The room temperature can be controlled by detecting the temperature accurately with built-in thermo sensor.
	Simple remote controller	UTY-RSNUM	Compact remote controller concentrates on the basic functions such as Start/Stop, Fan Control, Temperature Setting and Operation mode.

## 13-2. OTHERS

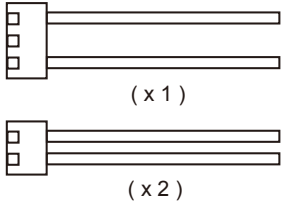
Exterior	Parts name	Model No.	Summary
 <p>( x 1 )</p> <p>( x 2 )</p>	External connect kit	UTY-XWZXZ5	Required when external device is connected.

## **2. OUTDOOR UNIT**

---

**SINGLE TYPE :**

**AOU9RLFF**

**AOU12RLFF**

**AOU15RLFF**

# CONTENTS

---

## 2. OUTDOOR UNIT

---

1. SPECIFICATIONS.....	02 - 01
2. DIMENSIONS .....	02 - 02
3. REFRIGERANT CIRCUIT .....	02 - 03
4. WIRING DIAGRAMS.....	02 - 05
5. CAPACITY COMPENSATION RATE FOR PIPE LENGTH AND HEIGHT DIFFERENCE .....	02 - 07
6. ADDITIONAL CHARGE CALCULATION.....	02 - 09
7. AIRFLOW .....	02 - 10
8. OPERATION NOISE.....	02 - 12
8-1. NOISE LEVEL CURVE .....	02 - 12
8-2. SOUND LEVEL CHECK POINT .....	02 - 14
9. ELECTRIC CHARACTERISTICS.....	02 - 15
10. SAFETY DEVICES .....	02 - 16

# 1. SPECIFICATIONS

OUTDOOR UNIT  
AOU9-15RLFF

OUTDOOR UNIT  
AOU9-15RLFF

Type				INVERTER HEAT PUMP			
Model name				AOU9RLFF	AOU12RLFF	AOU15RLFF	
Power source				208 / 230V ~ 60Hz			
Available voltage range				187 - 253V ~ 60Hz			
Starting current				A	4.1	6.7	7.0
Fan	Airflow rate	Cooling	CFM (m <sup>3</sup> /h)	1207 (2050)	1457 (2475)	1457 (2475)	
		Heating		1207 (2050)	1207 (2050)	1386 (2355)	
	Type x Q'ty		Propeller fan x 1				
	Motor output		W	115			
Sound pressure level		Cooling	dB (A)	49	53	54	
		Heating		50	52	54	
Heat exchanger type		Dimensions (H x W x D)		in.	23-1/8 x 34-11/16 x 1-7/16		
				mm	588 x 881 x 36.4		
		Fin pitch		FPI	20		
		Rows x Stages		2 x 28			
		Pipe type		Copper			
Fin Type		Aluminum					
Compressor	Type x Q'ty			Rotary x 1			
	Motor output			W	850	1000	
Refrigerant		Type		R410A			
		Charge	lbs.oz. kg	2lbs.10oz. 1.20	2lbs.12oz. 1.25		
Refrigerant oil		Type		FREOL α68SZ			
Enclosure		Material		Steel			
		Color		Beige Approximate color of MUNSELL 10YR7.5/1.0			
Dimensions (H x W x D)		Net		in.	24-7/16 x 31-1/8 x 11-7/16		
				mm	620 x 790 x 290		
		Gross		in.	28-1/16 x 37-3/16 x 15-9/16		
				mm	713 x 945 x 395		
Weight		Net		lbs.(kg)	84 (38)	86 (39)	
				Gross		93 (42)	95 (43)
Connenction pipe		Size	Liquid	in. (mm)	Ø 1/4 (Ø 6.35)		
			Gas		Ø 3/8 (Ø 9.52)		
		Method		Flare			
		Pre - charge length		ft. (m)	49 (15)		
		Max. length			66 (20)		
		Min. length			10 (3)		
Max. height difference		49 (15)					
Operation range		Cooling	°F (°C)	14 to 115 (-10 to 46)			
		Heating		-5 to 75 (-21 to 24)			

**NOTE:**

Specifications are based on the following conditions.  
 Cooling : Indoor temperature of 80°F (26.67°C) DB / 67°F (19.44°C) WB, and outdoor temperature of 95°F (35°C) DB / 75°F (23.9°C) WB.  
 Heating : Indoor temperature of 70°F (21.11°C) DB / 59°F (15°C) WB, and outdoor temperature of 47°F (8.33°C) DB / 43°F (6.11°C) WB.  
 Pipe length : 24ft.(7.5m), Height difference:0 m. (Outdoor unit - Indoor unit)  
 The protective function might work when using it outside the operation range.

## 2. DIMENSIONS

### ■ MODEL: AOU9RLFF, AOU12RLFF, AOU15RLFF

Unit: in. (mm)

OUTDOOR UNIT  
AOU9-15RLFF

OUTDOOR UNIT  
AOU9-15RLFF

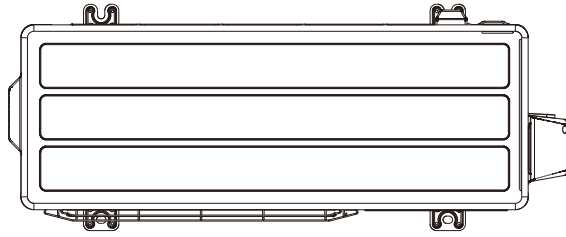

Top view

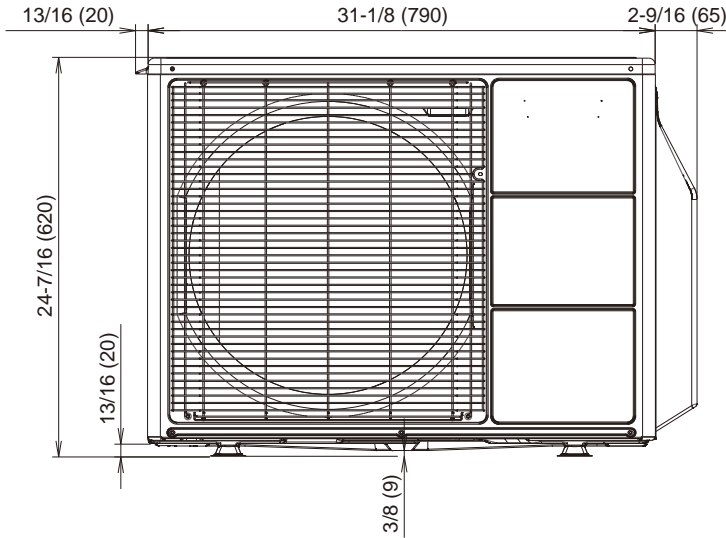

Front view

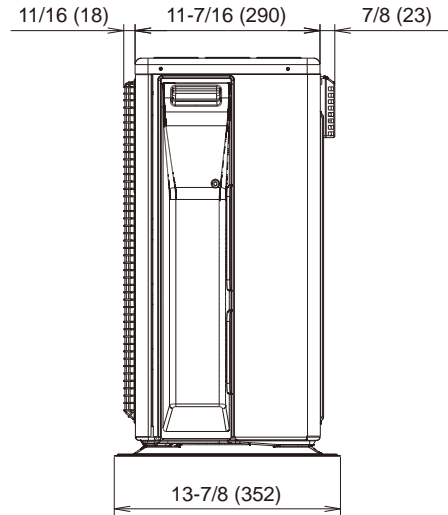

Side view

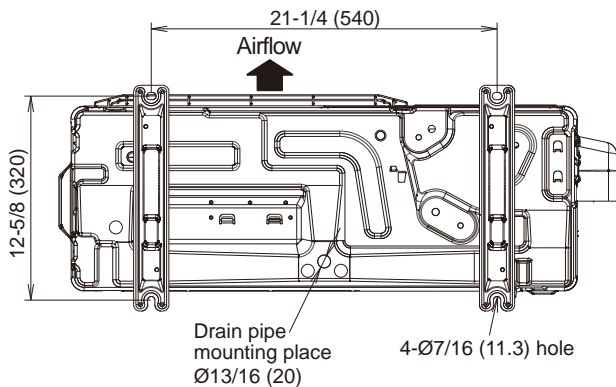

Bottom view

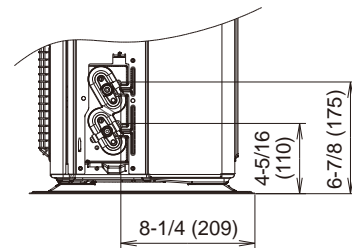

Drain pipe mounting place  $\varnothing 13/16$  (20)  
4- $\varnothing 7/16$  (11.3) hole

### ■ INSTALLATION PLACE

When there are obstacles at the back or front sides.

When there are obstacles at the back, side(s), and top.

When there are obstacles at the back, side with the installation of more than one unit.

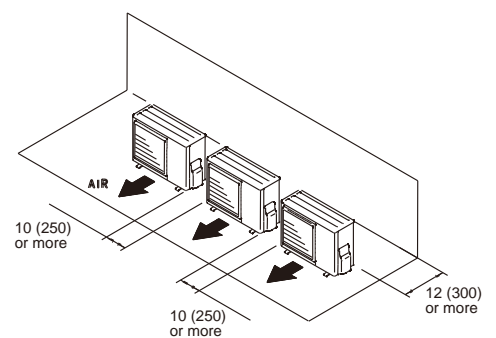
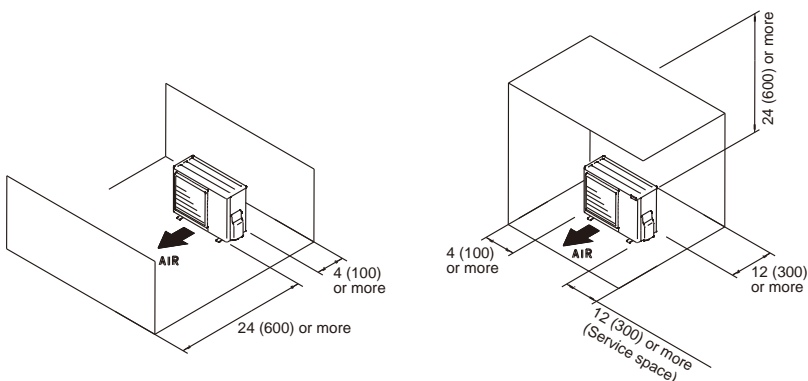

### 3. REFRIGERANT CIRCUIT

■ MODEL: AOU9RLFF, AOU12RLFF

OUTDOOR UNIT  
AOU9-15RLFF

OUTDOOR UNIT  
AOU9-15RLFF

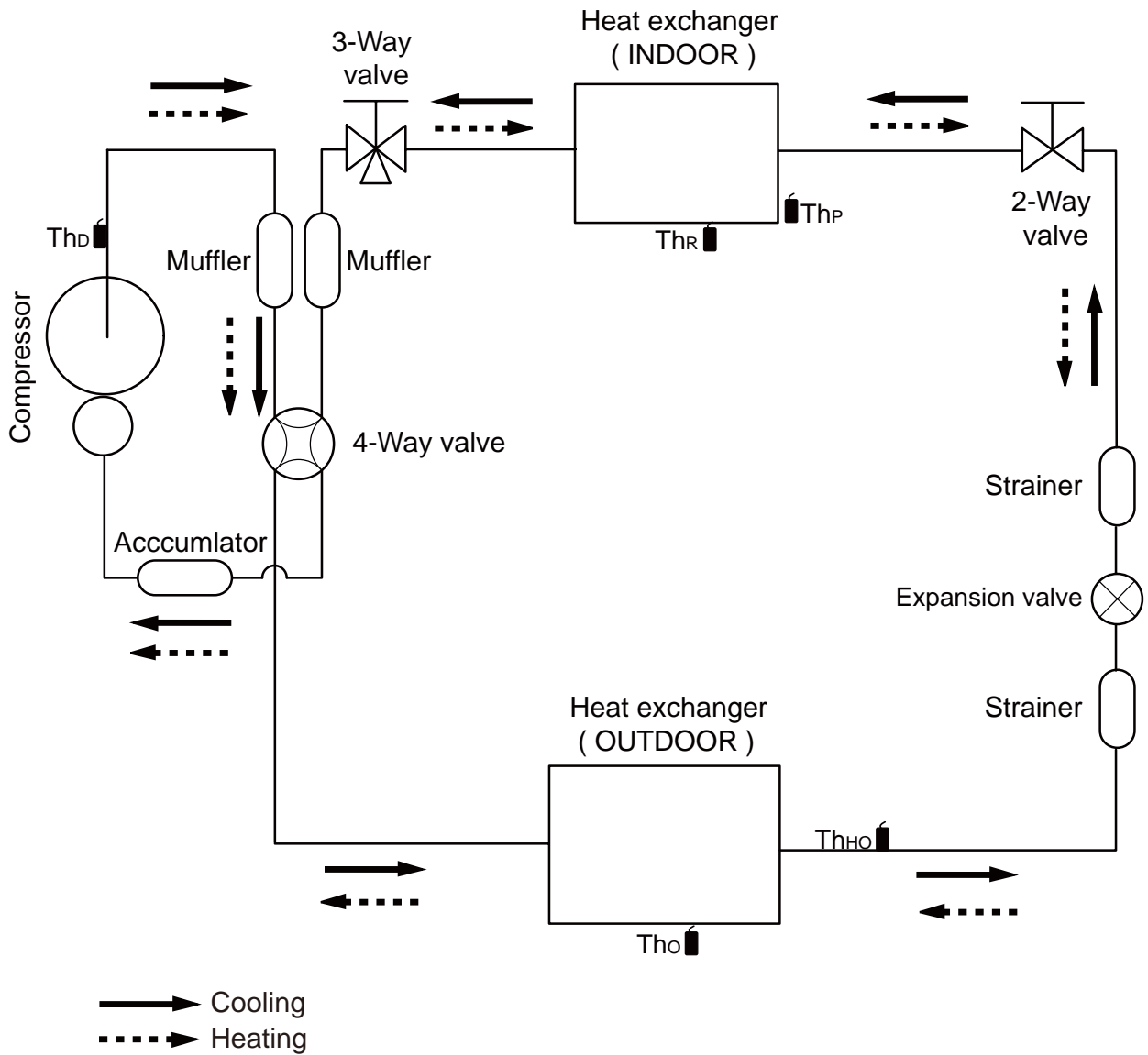

- Th<sub>D</sub> : Thermistor (Discharge Temp.)
- Th<sub>O</sub> : Thermistor (Outdoor Temp.)
- Th<sub>HO</sub> : Thermistor (Heat Exchanger Out Temp.)
- Th<sub>R</sub> : Thermistor (Room Temp.)
- Th<sub>P</sub> : Thermistor (Pipe Temp.)

Refrigerant pipe diameter  
 Liquid: 1/4" (6.35 mm)  
 Gas: 3/8" (9.52 mm): 9/12RLFF

# MODEL: AOU15RLFF

OUTDOOR UNIT  
AOU9-15RLFF

OUTDOOR UNIT  
AOU9-15RLFF

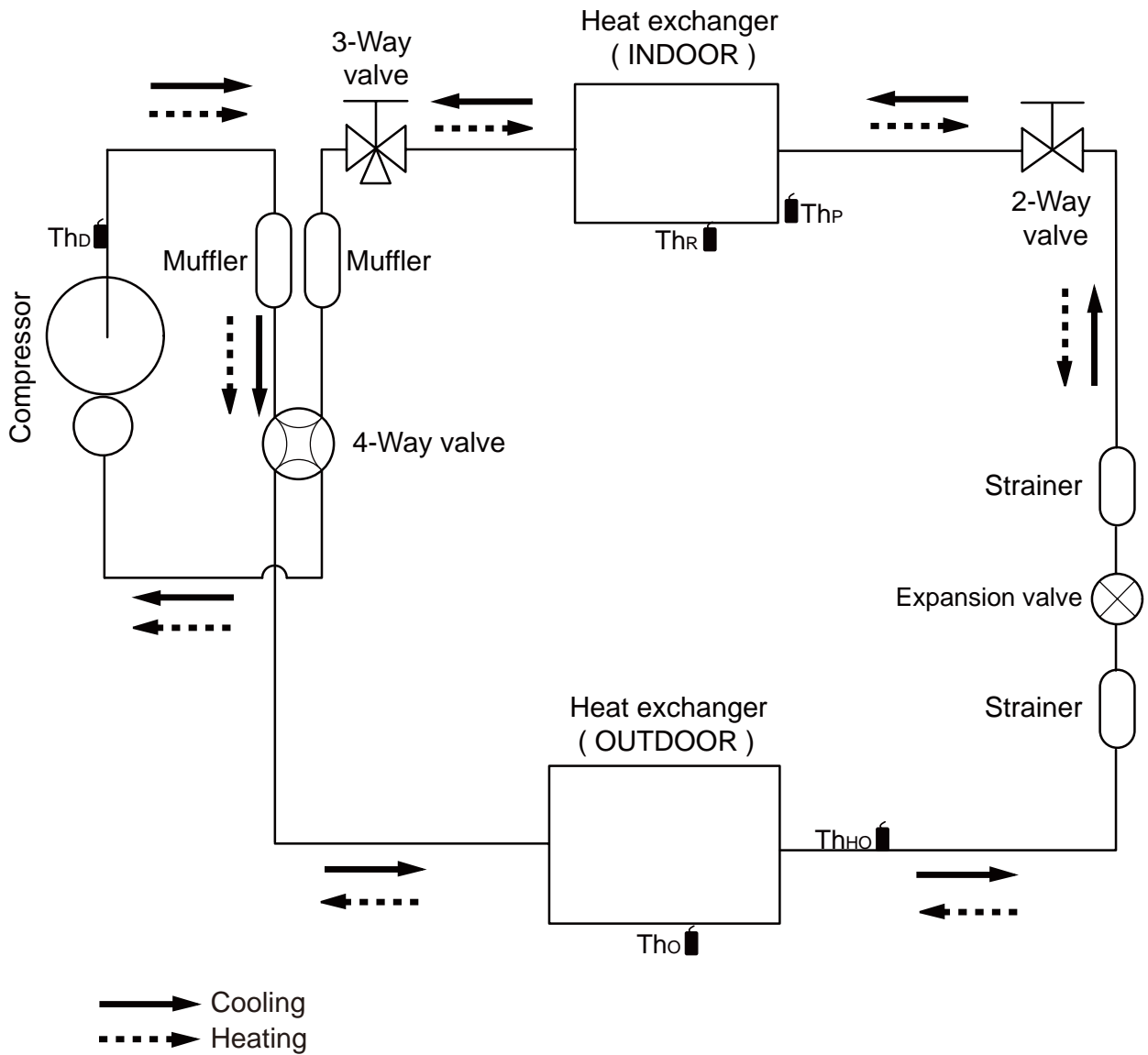

- Th<sub>D</sub> : Thermistor (Discharge Temp.)
- Th<sub>O</sub> : Thermistor (Outdoor Temp.)
- Th<sub>HO</sub> : Thermistor (Heat Exchanger Out Temp.)
- Th<sub>R</sub> : Thermistor (Room Temp.)
- Th<sub>P</sub> : Thermistor (Pipe Temp.)

Refrigerant pipe diameter  
 Liquid: 1/4" (6.35 mm)  
 Gas: 1/2" (12.70 mm): 15RLFF

# 4. WIRING DIAGRAMS

## ■ MODEL: AOU9RLFF, AOU12RLFF

OUTDOOR UNIT  
AOU9-15RLFF

OUTDOOR UNIT  
AOU9-15RLFF

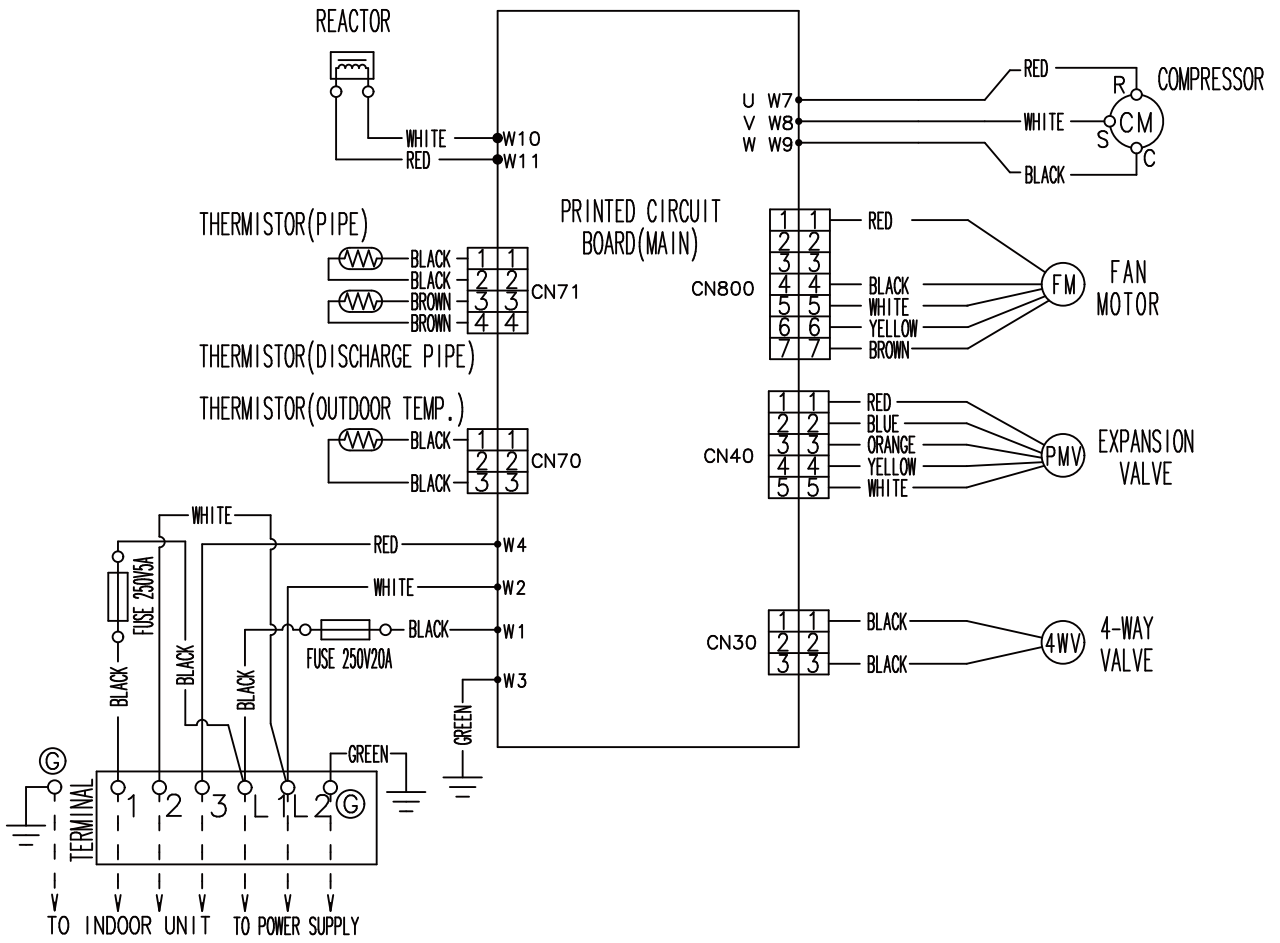



# MODEL: AOU15RLFF

OUTDOOR UNIT  
AOU9-15RLFF

OUTDOOR UNIT  
AOU9-15RLFF

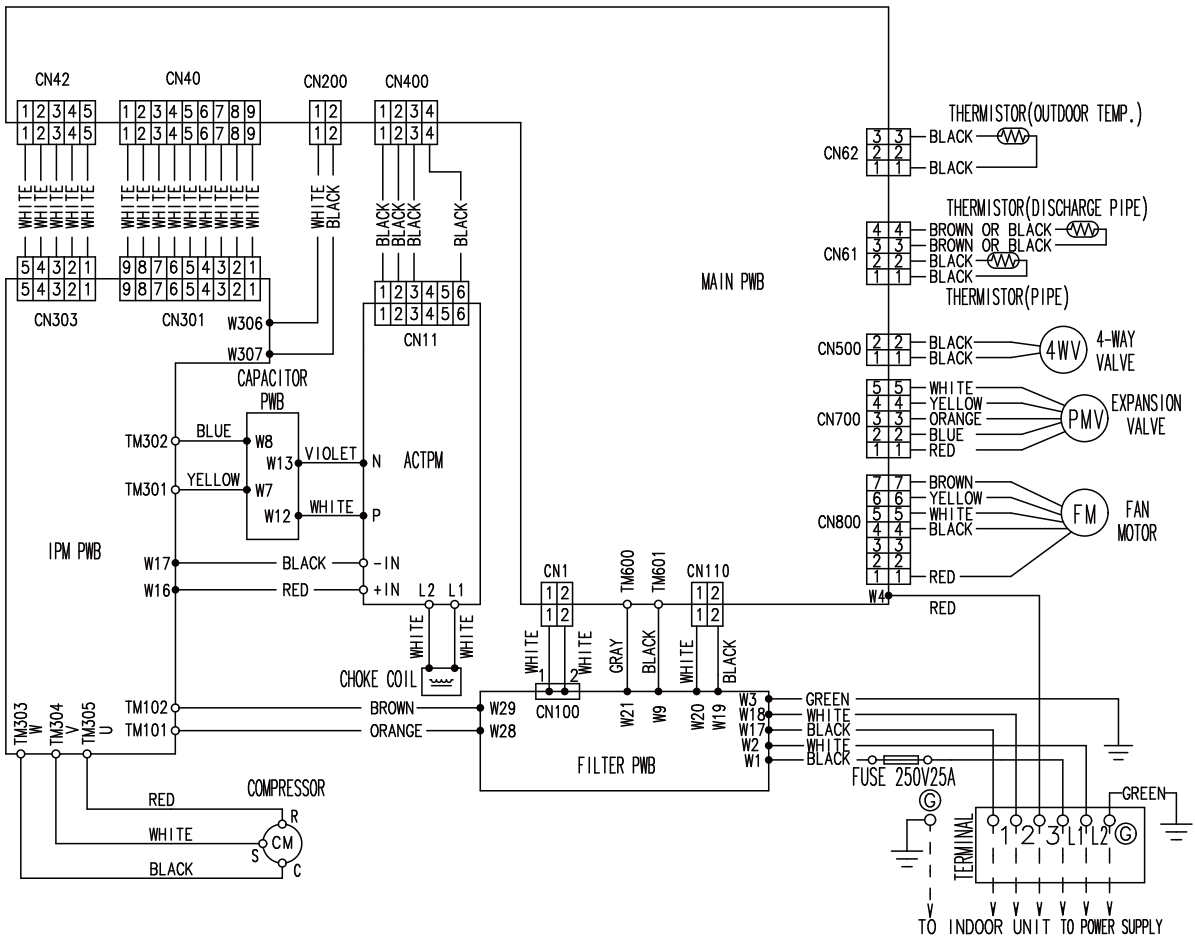

# 5. CAPACITY COMPENSATION RATE FOR PIPE LENGTH AND HEIGHT DIFFERENCE

## MODEL: AOU9RLFF, AOU12RLFF

OUTDOOR UNIT  
AOU9-15RLFF

OUTDOOR UNIT  
AOU9-15RLFF

COOLING				Pipe length (m)				
				5m	7.5m	10m	15m	20m
				17ft.	25ft.	33ft.	50ft.	67ft.
Height difference H	*1 Indoor unit is higher than outdoor unit.	15m	50ft.	-	-	-	0.893	0.909
		10m	33ft.	-	-	0.955	0.908	0.924
		7.5m	25ft.	-	0.975	0.959	0.912	0.928
		5m	17ft.	0.992	0.979	0.963	0.916	0.931
	*2 Indoor unit is lower than outdoor unit	0m	0ft.	1.000	0.987	0.970	0.923	0.939
		-5m	-17ft.	1.000	0.987	0.970	0.923	0.939
		-7.5m	-25ft.	-	0.987	0.970	0.923	0.939
		-10m	-33ft.	-	-	0.970	0.923	0.939
		-15m	-50ft.	-	-	-	0.923	0.939

HEATING				Pipe length (m)				
				5m	7.5m	10m	15m	20m
				17ft.	25ft.	33ft.	50ft.	67ft.
Height difference H	*1 Indoor unit is higher than outdoor unit.	15m	50ft.	-	-	-	0.956	0.938
		10m	33ft.	-	-	1.004	0.956	0.938
		7.5m	25ft.	-	1.013	1.004	0.956	0.938
		5m	17ft.	1.000	1.013	1.004	0.956	0.938
	*2 Indoor unit is lower than outdoor unit	0m	0ft.	1.000	1.013	1.004	0.956	0.938
		-5m	-17ft.	0.995	1.008	0.999	0.951	0.933
		-7.5m	-25ft.	-	1.005	0.997	0.948	0.931
		-10m	-33ft.	-	-	0.994	0.946	0.929
		-15m	-50ft.	-	-	-	0.937	0.919

Height difference H

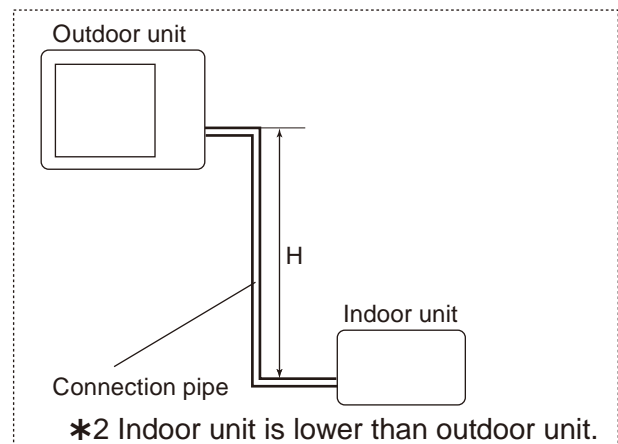
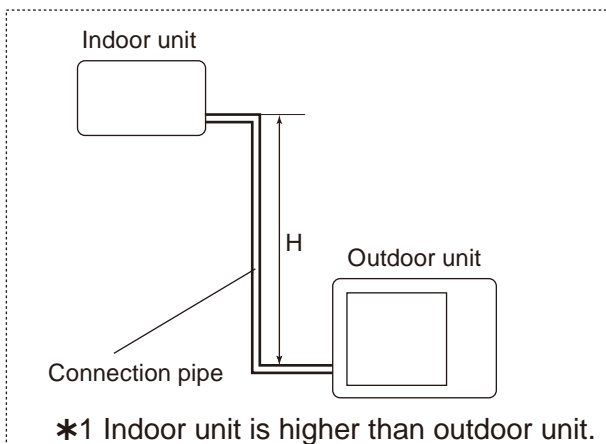

# MODEL: AOU15RLFF

OUTDOOR UNIT  
AOU9-15RLFF

OUTDOOR UNIT  
AOU9-15RLFF

COOLING				Pipe length (m)				
				5m	7.5m	10m	15m	20m
				17ft.	25ft.	33ft.	50ft.	67ft.
Height difference H	*1 Indoor unit is higher than outdoor unit.	15m	50ft.	-	-	-	0.951	0.950
		10m	33ft.	-	-	0.979	0.967	0.966
		7.5m	25ft.	-	0.988	0.983	0.971	0.970
		5m	17ft.	0.994	0.992	0.987	0.975	0.974
	*2 Indoor unit is lower than outdoor unit	0m	0ft.	1.002	1.000	0.995	0.983	0.982
		-5m	-17ft.	1.002	1.000	0.995	0.983	0.982
		-7.5m	-25ft.	-	1.000	0.995	0.983	0.982
		-10m	-33ft.	-	-	0.995	0.983	0.982
		-15m	-50ft.	-	-	-	0.983	0.982

HEATING				Pipe length (m)				
				5m	7.5m	10m	15m	20m
				17ft.	25ft.	33ft.	50ft.	67ft.
Height difference H	*1 Indoor unit is higher than outdoor unit.	15m	50ft.	-	-	-	0.994	0.979
		10m	33ft.	-	-	1.012	0.994	0.979
		7.5m	25ft.	-	1.000	1.012	0.994	0.979
		5m	17ft.	0.969	1.000	1.012	0.994	0.979
	*2 Indoor unit is lower than outdoor unit	0m	0ft.	0.969	1.000	1.012	0.994	0.979
		-5m	-17ft.	0.964	0.995	1.007	0.989	0.974
		-7.5m	-25ft.	-	0.993	1.004	0.986	0.972
		-10m	-33ft.	-	-	1.002	0.984	0.969
		-15m	-50ft.	-	-	-	0.974	0.959

Height difference H

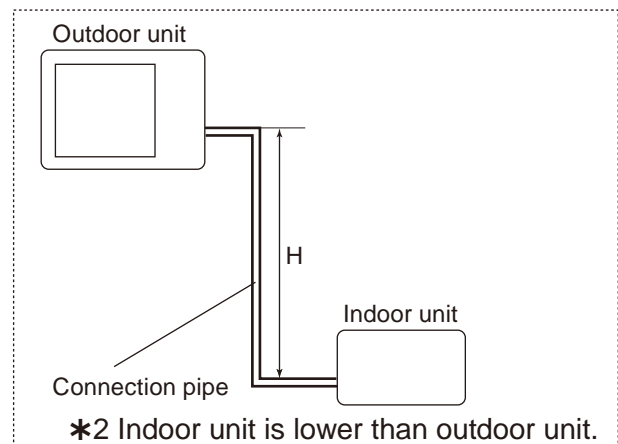
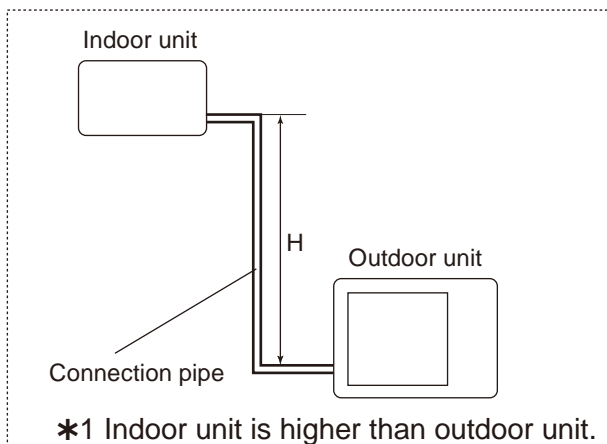

## 6. ADDITIONAL CHARGE CALCULATION

### ■ MODEL: AOU9RLFF, AOU12RLFF

Refrigerant type		R410A
Refrigerant amount	lbs. oz.	2lbs.10oz.
	g	1200

#### ● Refrigerant charge

Pipe length	ft.	49 or less	66 (MAX)	0.22oz./ft. (20g/m)
	m	15 or less	20 (MAX)	
Additional charge	oz.	0	+3.5	
	g	0	+100	

### ■ MODEL: AOU15RLFF

Refrigerant type		R410A
Refrigerant amount	lbs. oz.	2lbs.12oz.
	g	1250

#### ● Refrigerant charge

Pipe length	ft.	49 or less	66 (MAX)	0.22oz./ft. (20g/m)
	m	15 or less	20 (MAX)	
Additional charge	oz.	0	+3.5	
	g	0	+100	

## 7. AIRFLOW

### ■ MODEL: AOU9RLFF

#### ● Cooling

Number of rotations (r.p.m.)	Airflow	
	870	m <sup>3</sup> /h
l/s		569
CFM		1207

#### ● Heating

Number of rotations (r.p.m.)	Airflow	
	870	m <sup>3</sup> /h
l/s		569
CFM		1207

### ■ MODEL: AOU12RLFF

#### ● Cooling

Number of rotations (r.p.m.)	Airflow	
	1050	m <sup>3</sup> /h
l/s		688
CFM		1457

#### ● Heating

Number of rotations (r.p.m.)	Airflow	
	870	m <sup>3</sup> /h
l/s		569
CFM		1207

## ■ MODEL: AOU15RLFF

### ● Cooling

Number of rotations (r.p.m.)	Airflow	
	1050	m <sup>3</sup> /h
l/s		688
CFM		1457

### ● Heating

Number of rotations (r.p.m.)	Airflow	
	1000	m <sup>3</sup> /h
l/s		654
CFM		1386

# 8. OPERATION NOISE

## 8-1. NOISE LEVEL CURVE

### MODEL: AOU9RLFF

#### ● Cooling

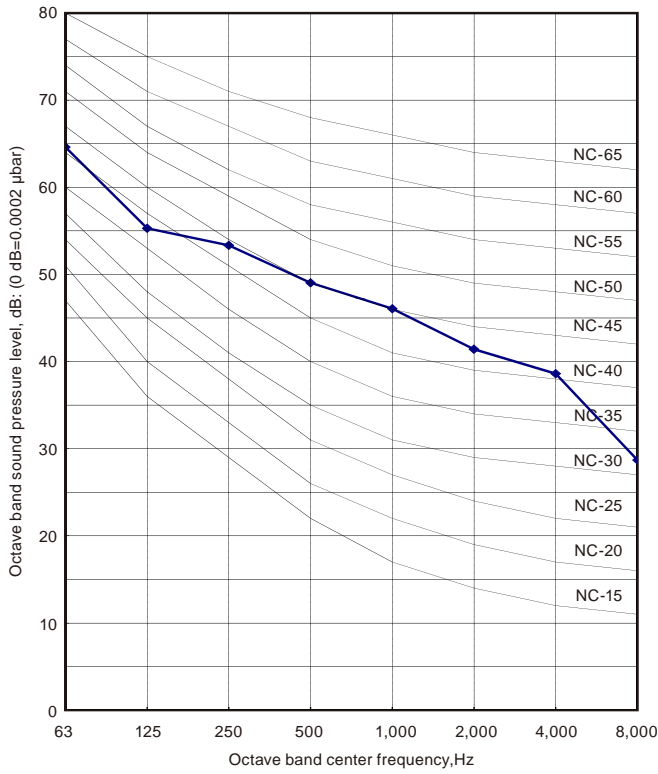

#### ● Heating

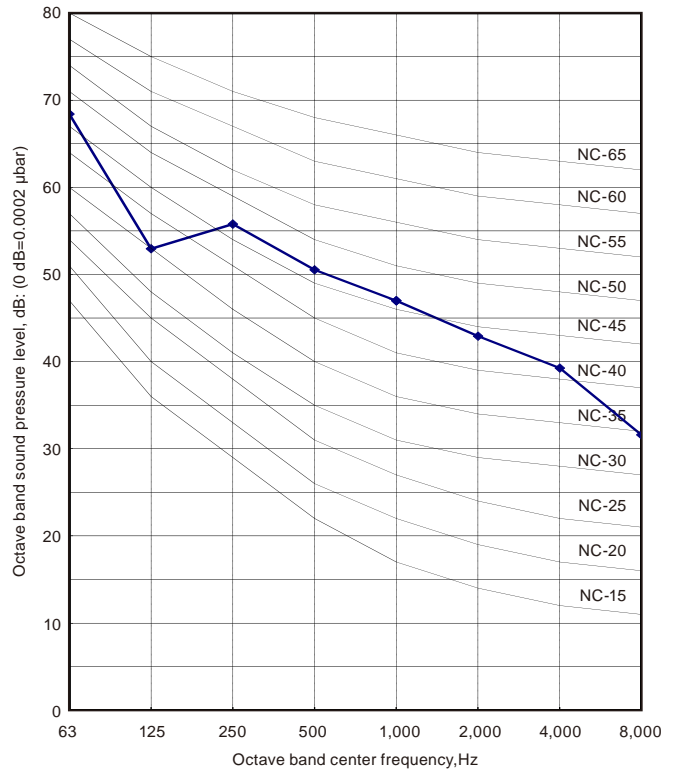

### MODEL: AOU12RLFF

#### ● Cooling

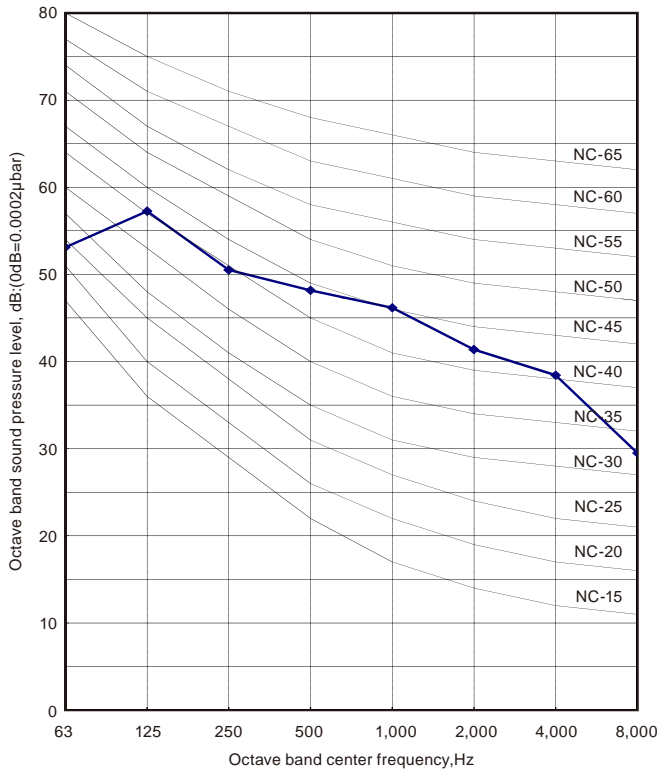

#### ● Heating

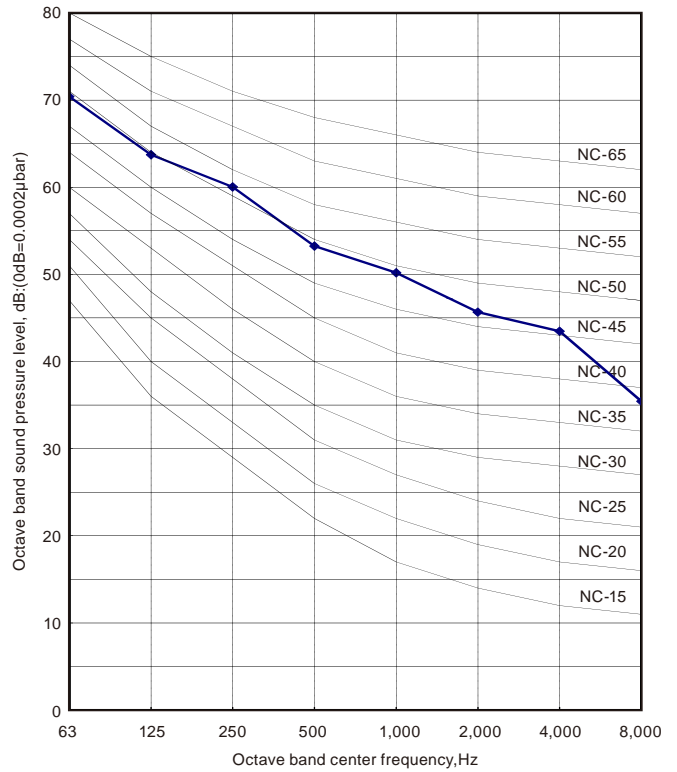

OUTDOOR UNIT  
AOU9-15RLFF

OUTDOOR UNIT  
AOU9-15RLFF

# MODEL: AOU15RLFF

## ● Cooling

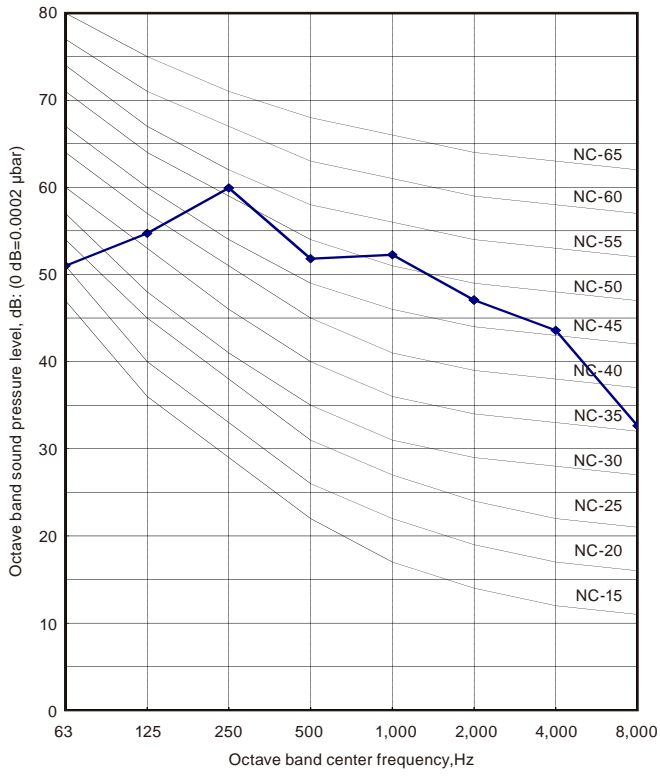

## ● Heating

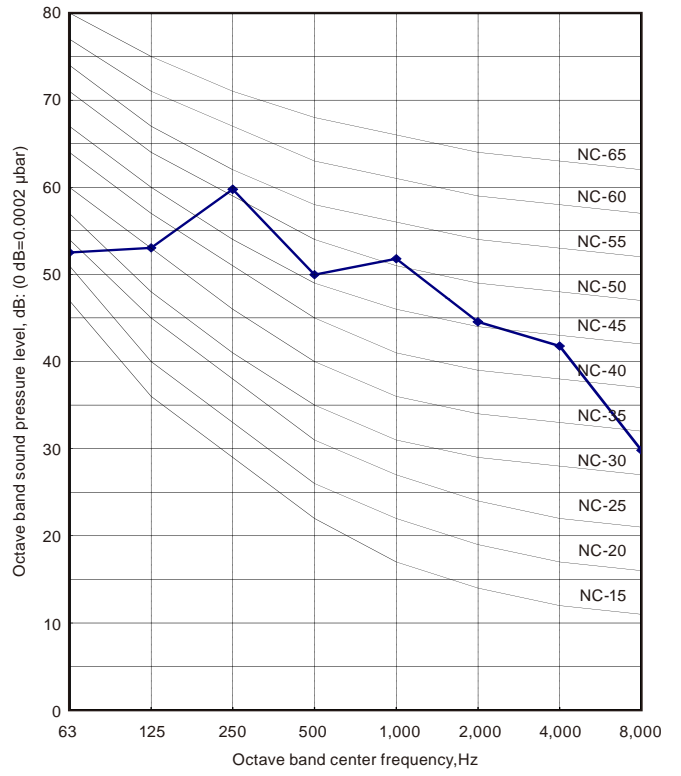



# 8-2. SOUND LEVEL CHECK POINT

OUTDOOR UNIT  
AOU9-15RLFF

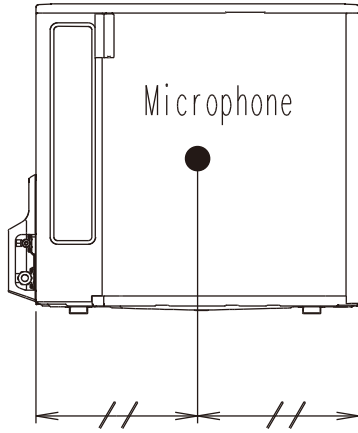
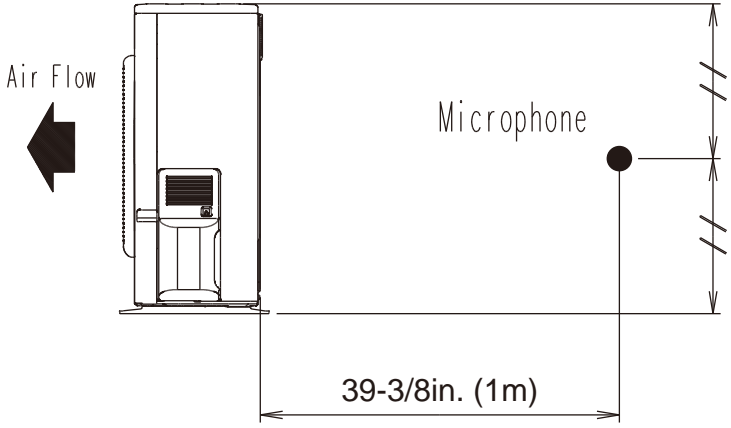

OUTDOOR UNIT  
AOU9-15RLFF

## 9. ELECTRIC CHARACTERISTICS

Model name			AOU9RLFF	AOU12RLFF	AOU15RLFF
Power supply	Voltage	V	208 / 230 ~		
	Frequency	Hz	60		
MCA		A	10.8		13.8
Starting Current		A	4.1	6.7	7.0
*1) Wiring Spec.:	MAX. CKT. BKR	A	15		20
	Power Cable	AWG	14		12

\*1) Wiring Spec.:

Selected Sample

(Selected based on Japan Electrotechnical Standard and Codes Committee E0005)

MCA: Min Circuit Amp(Calculation based on UL1995)

MAX. CKT. BKR: Maximum Circuit Breaker

# 10. SAFETY DEVICES

OUTDOOR UNIT  
AOU9-15RLFF

OUTDOOR UNIT  
AOU9-15RLFF

	Protection form	Model		
		AOU9RLFF	AOU12RLFF	AOU15RLFF
Circuit protection	Current fuse (Near the terminal)	250V 20A		250V 25A
		250V 5A		
	Current fuse (Main printed circuit board)	250V 15A		250V 10A
		250V 3.15A		250V 3.15A
Fan motor protection	Thermal protection program	OFF: 212 ± 27 °F (100 ± 15 °C) ON: 203 ± 18 °F (95 ± 10 °C)		
Compressor protection	Thermal protection program (Discharge temp.)	OFF: 230 °F (110 °C) ON: After 7 minutes		