

SpecAdvantage™

For Commercial and Industrial Applications

Specifications

Tankless Electric Water Heater

Applications

- Designed for low duty cycle applications where precise temperature controls and low pressure drop are required

Features

- Designed for commercial and industrial applications
- Capable of high volume and high temperature applications at low duty cycle
- Fully modulating - Predictive control algorithm and diverse safety features ensures precise temperature control
- T&P not required per UL499 (check local codes)
- Thermo-Optical Sensor for infrared element monitoring
- Field programmable, updatable firmware, and adjustable turn-on

Optional Features (NEMA cabinet required)

- N4 (powder coated steel), N4X (304SS) N4X6 (316SS) enclosures
- Free standing legs
- Freeze protection for harsh climate, up to -30°F
- Non-fused or fused electrical disconnect
- GFCI
- Explosion proof – C1D2 Compliant, local certification required. Class Z purge and pressurization system provided with pressure switch for alarm controls. For classification other than C1D2 please contact the factory to discuss options.
- Siren and beacon - audible and visual alarm (C1D2 compliant when paired with explosion proof package)

Product Specifications

Min. Operating Pressure: 35 PSI

Max. Operating Pressure: 150 PSI

Optimum Operating Pressure: 60-90 PSI

U.S. Patent #'s: US20140023354 and US20140178057

Installation Requirements

- Properly sized water hammer arrestor
- Minimum 35 PSI dynamic pressure at inlet
- Sediment filter installed on inlet

Special Design Service

- Inquiries for units for unique applications are welcome. Call our Technical Service department at **1 800 543 6163**.
- Custom orders non-refundable

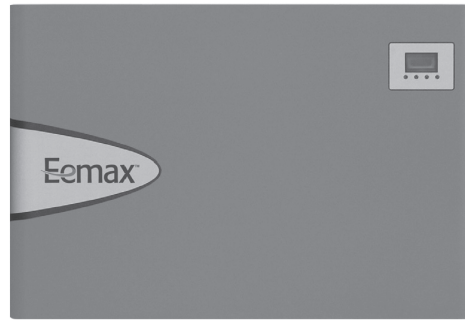

Suggested Specification

Tankless water heater shall be an Eemax SpecAdvantage model number AP _____.

Optional factory installation in a ____ (N4/N4X/N4X6) enclosure.

Enclosure to be fitted with the following features:

<input type="checkbox"/> FP	Freeze protection (-30°F)
<input type="checkbox"/> EDS	Non-fused disconnect
<input type="checkbox"/> FDS	Fused disconnect
<input type="checkbox"/> EP	Explosion proof (C1D2 compliant)
<input type="checkbox"/> GFCI	True RMS GFCI with digital display and reset
<input type="checkbox"/> SK	24" legs for free standing applications
<input type="checkbox"/> RD	Remote display
<input type="checkbox"/> SB	Siren and Beacon
<input type="checkbox"/> DC	Dry contact
<input type="checkbox"/> ES	Emergency stop - push button

Tankless water heater must have water connections on the bottom, and be constructed with NSF 61 listed materials. Direct heating element to be non-ferrous, cartridge style, designed for field replacement. Tankless water heater to utilize a dual PID algorithm, actively managing power application to real-time system demand. Integrated flow meter capable of volumes in excess of 30 GPM drives predictive control algorithm. Water heater must be protected by redundant safeties. Redundant safeties to include thermo mechanical safety switches, infrared element monitoring via thermo optical sensors, and dual temperature monitoring via master control board. Tankless water heater user interface must have the following capabilities:

- Selectable display including Celsius/Fahrenheit, inlet temperature, outlet temperature, flow rate, and setpoint temperature.
- Capable of displaying flow rate in gallons per minute or liters per minute.
- Diagnostic features to include error and fault code display.
- Control board must maintain error/fault history of 9 events.
- Capable of factory coded temperature setting (max. and min.)
- Capable of firmware upgrades via USB port
- Capable of BMS integration - contact factory
- Compliant with ANSI Z358.1 tepid water without additional mixing or purge features (inlet temperatures must not exceed 100°F when selecting an EE or EFD option)

NOTE: For recirculation applications, follow the installation schematics in the installation manual.

SpecAdvantage

For Commercial and Industrial Applications

Specifications Tankless Electric Water Heater

Suffix Definitions

S Sanitation. Shipped at 180°F with temp range of 100°F-180°F max.

EE Emergency Eyewash. Max. outlet temperature 90°F. Conforms to ANSI Z358.1 tepid water without additional mixing valve. Shipped with display "Locked."

EFD Emergency Eye, Face & Drench. Max. outlet temperature 90°F. Conforms to ANSI Z358.1 tepid water without additional mixing valve. Shipped with display "Locked."

Note: Models with an EE or EFD suffix are not to be fed to a thermostatic mixing valve. If a thermostatic mixing valve is required, heater of non EE or EFD must be specified.

Note: Models with an EE or EFD suffix have a 90°F maximum temperature. Temperature rise data is provided for reference, but temperature is electronically limited to factory preset not to exceed temperature.

MODEL NUMBER	KW	BTU/H	AMPS PER PHASE	TURN ON (GPM)	RECOMMENDED WIRE SIZE (75° C/CU)	TEMPERATURE RISE °F																	
						3.0 GPM	4.0 GPM	5.0 GPM	6.0 GPM	20.0 GPM	23.0 GPM	26.0 GPM	30.0 GPM										
VOLTS 208 Three Phase Delta																							
AP032208	32	109,189	89	1.0*	3AWG	73°	55°	44°	36°	11°	10°	8°	7°										
AP032208 EE	32	109,189	89	1.0	3 AWG	†	55°	44°	36°	11°	10°	8°	7°										
AP032208 S	32	109,189	89	2.5**	3 AWG	73°	55°	44°	36°	11°	10°	8°	7°										
AP036208	36	122,832	100	1.0*	3 AWG	82°	61°	49°	41°	12°	11°	9°	8°										
AP036208 EE	36	122,832	100	1.0	3 AWG	†	†	49°	41°	12°	11°	9°	8°										
AP036208 S	36	122,832	110	2.5**	3 AWG	82°	61°	49°	41°	12°	11°	9°	8°										
AP041208	41	143,310	113	1.0*	2 AWG	93°	70°	56°	47°	14°	12°	11°	9°										
AP041208 EFD	41	143,310	113	1.0	2 AWG	†	†	56°	47°	14°	12°	11°	9°										
AP041208 S	41	143,310	113	2.5**	2 AWG	93°	70°	56°	47°	14°	12°	11°	9°										
AP054208	54	184,256	150	1.5*	1/0 AWG	†	92°	74°	61°	18°	16°	14°	12°										
AP054208 EFD	54	184,256	150	1.5	1/0 AWG	†	†	†	†	18°	16°	14°	12°										
AP054208 S	54	184,256	150	6.0**	1/0 AWG	123°	92°	74°	61°	18°	16°	14°	12°										
AP064208	64	218,377	178	2.5	3/0 AWG	†	109°	87°	73°	22°	19°	17°	15°										
AP064208 EFD	64	218,377	178	2.5	3/0 AWG	†	†	†	†	22°	19°	17°	15°										
AP064208 S	64	218,377	178	6.0**	3/0 AWG	146°	109°	87°	73°	22°	19°	17°	15°										
VOLTS 480 Three Phase Delta																							
AP036480	36	122,837	43	1.0*	8 AWG	82°	61°	49°	41°	12°	11°	9°	8°										
AP036480 EE	36	122,837	43	1.0	8 AWG	†	†	49°	41°	12°	11°	9°	8°										
AP036480 S	36	122,837	43	2.5**	8 AWG	82°	61°	49°	41°	12°	11°	9°	8°										
AP039480	39	133,074	47	1.0*	8 AWG	89°	67°	53°	44°	13°	12°	10°	9°										
AP039480 EE	39	133,074	47	1.0	8 AWG	†	†	53°	44°	13°	12°	10°	9°										
AP039480 S	39	133,074	47	2.5**	8 AWG	89°	67°	53°	44°	13°	12°	10°	9°										
AP048480	48	163,783	58	1.0*	6 AWG	109°	82°	66°	55°	16°	14°	13°	11°										
AP048480 EFD	48	163,783	58	1.0	6 AWG	†	†	†	†	16°	14°	13°	11°										
AP048480 S	48	163,783	58	2.5**	6 AWG	109°	82°	66°	55°	16°	14°	13°	11°										
AP054480	54	184,256	65	1.5*	6 AWG	†	92°	74°	61°	18°	16°	14°	12°										
AP054480 EFD	54	184,256	65	1.5	6 AWG	†	†	†	†	18°	16°	14°	12°										
AP054480 S	54	184,256	65	2.5**	6 AWG	123°	92°	74°	61°	18°	16°	14°	12°										
AP063480	63	214,965	76	2.5	4 AWG	†	108°	86°	72°	22°	19°	17°	14°										
AP063480 EFD	63	214,965	76	2.5	4 AWG	†	†	†	†	22°	19°	17°	14°										
AP063480 S	63	214,965	76	6.0**	4 AWG	143°	108°	86°	72°	22°	19°	17°	14°										
AP072480	72	245,674	87	2.5	3 AWG	†	†	98°	82°	25°	21°	19°	16°										
AP072480 EFD	72	245,674	87	2.5	3 AWG	†	†	†	†	25°	21°	19°	16°										
AP072480 S	72	245,674	87	6.0**	3 AWG	†	123°	98°	82°	25°	21°	19°	16°										
AP096480	96	327,552	116	2.5	1 AWG	†	†	†	109°	33°	29°	25°	22°										
AP096480 EFD	96	327,552	116	2.5	1 AWG	†	†	†	†	33°	29°	25°	22°										
AP096480 S	96	327,552	116	6.0**	1 AWG	†	†	131°	109°	33°	29°	25°	22°										
AP108480	108	368,511	130	2.5	1 AWG	†	†	†	†	37°	32°	28°	25°										
AP108480 EFD	108	368,511	130	2.5	1 AWG	†	†	†	†	37°	32°	28°	25°										
AP108480 S	108	368,511	130	6.0**	1 AWG	†	†	148°	123°	37°	32°	28°	25°										
AP126480	126	429,930	151	2.5	2/0 AWG	†	†	†	†	43°	37°	33°	29°										
AP126480 EFD	126	429,930	151	2.5	2/0 AWG	†	†	†	†	43°	37°	33°	29°										
AP126480 S	126	429,930	151	6.0**	2/0 AWG	†	†	†	143°	43°	37°	33°	29°										
C AP144480	144	491,348	173	2.5	2/0 AWG	†	†	†	†	49°	43°	38°	33°										
C AP144480 EFD	144	491,348	173	2.5	2/0 AWG	†	†	†	†	49°	43°	38°	33°										
C AP144480 S	144	491,348	173	6.0**	2/0 AWG	†	†	†	†	49°	43°	38°	33°										
VOLTS 600 Three Phase Delta																							
C AP061600 EFD	61	208,141	59	2.5	6 AWG	†	†	†	†	21°	18°	16°	14°										
C AP071600 EFD	71	242,262	68	2.5	4 AWG	†	†	†	†	24°	21°	19°	16°										
C AP102600 EFD	102	348,038	98	2.5	3 AWG	†	†	†	†	35°	30°	27°	23°										
C AP130600 EFD	130	443,578	125	2.5	1 AWG	†	†	†	†	44°	39°	34°	30°										
C AP150600 EFD	150	511,821	144	2.5	1/0 AWG	†	†	†	†	51°	45°	39°	34°										

* Units with a 1.0 or 1.5 GPM turn-on are limited to 120°F only. Contact Eemax support for applications above 120°F.

† Temperature electronically limited to factory preset temperature.

"C" indicates evaluation and compliance to either Underwriters Laboratories (UL) or Intertek (ETL) under CAN/CSA-C22.2 No. 64/No. 88.

** Contact Eemax for applications requiring lower turn on.

Electrical configuration and requirements

All Eemax three phase units are custom made to order and as such, are non-returnable and non-refundable. Check your electrical supply, making sure all criteria for operating your Eemax water heater are met

Eemax 600V, 480V and 208V Three Phase Units Delta Configuration

Requires: 3 Lives and 1 Ground (earth)

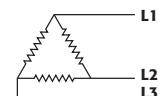

SpecAdvantage

For Commercial and Industrial Applications

Specifications

Tankless Electric Water Heater

Base Model Dimensions

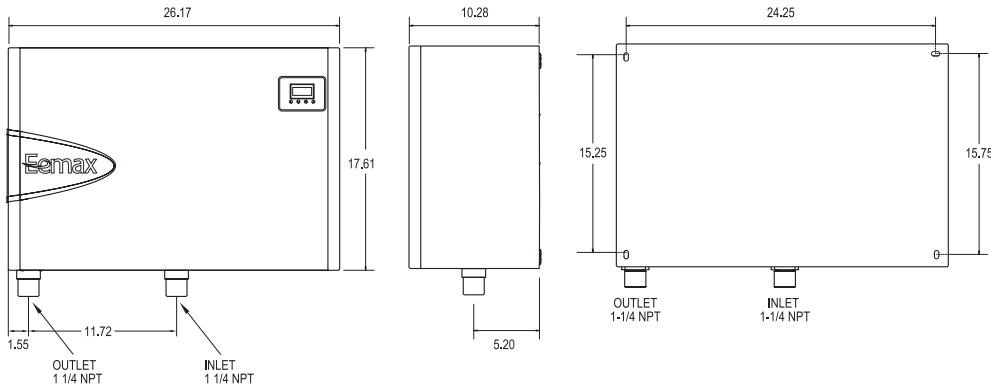

65 lb
Designed for wall mount installation.

NEMA Cabinet Options*

Dimensions: 24"H x 30"W x 13.5"D

- N4** Powder coated steel
- N4X** Corrosion-resistant 304 stainless steel
- N4X6** Corrosion-resistant 316 stainless steel

Est. total weight 130 lb
Designed for wall mounted installation. Free standing legs and other options available

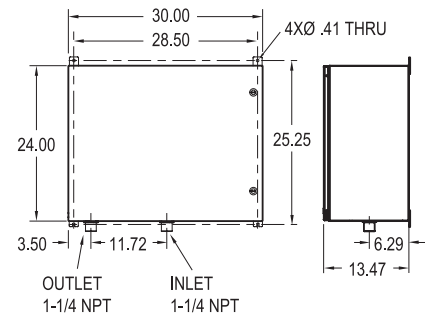

NEMA Cabinet Options Accessories

Dimensions: 36"H x 30"W x 17.3"D

- FP** Freeze protection (-30°F)
- EDS** Non-fused disconnect
- FDS** Fused disconnect
- EP** Explosion proof (C1D2 compliant)
- GFCI** True RMS GFCI with digital display and reset
- SK** 24" legs for free standing applications
- RD** Remote display
- SB** Siren and Beacon
- DC** Dry contact
- ES** Emergency stop - push button

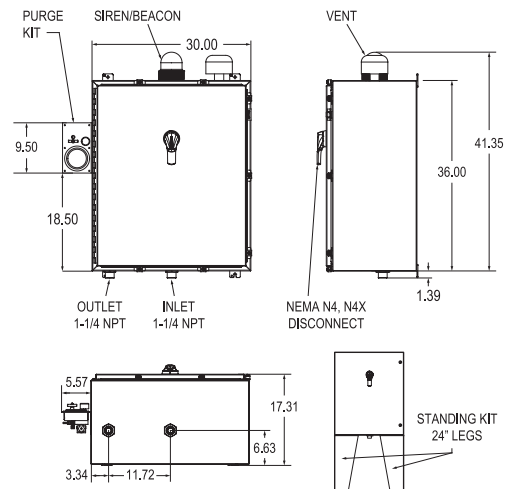

Est. total weight 225 lb, varies based on options.
Designed for wall mounted installation. Free standing legs and other options available.

*Refer to page 47 of this specification guide for more details regarding selection.

SpecAdvantage

For Commercial and Industrial Applications

Specifications

Tankless Electric Water Heater

Unit Selection

Base Model (No Suffix)

All SpecAdvantage models are designed for low duty cycle applications where precise temperature controls and low pressure are required. Models without a suffix are set to a maximum temperature of 140°F if the turn on is greater than 1.5 GPM. Models with a 1.0 or 1.5 GPM turn on are limited to 120°F.

Suffixes:

S Sanitation. For applications that require high-temperature delivery. Units shipped at 180°F.

EE Emergency Eyewash. ANSI Z3581.1 tepid water for emergency eyewash stations

EFD Emergency Eye, Face & Drench. ANSI Z3581.1 tepid water for emergency eye, face, and drench showers

Select the best model based on your hot water requirements. You need a proportional amount of energy to heat the flow (GPM) needed for the application. The chart below shows a range of possible applications and the recommended unit size (kW).

NOTE: For simple calculation, kW reference is based on a 100% heater efficiency.
kW Required = GPM x (temp rise/6.83)

GPM	TEMPERATURE RISE °F														
	20°	30°	40°	50°	60°	70°	80°	90°	100°	110°	120°	130°	140°	150°	
VOLTS 208 Three Phase Delta															
1.5	32 kW	32 kW	32 kW	32 kW	32 kW	32 kW	32 kW	32 kW	32 kW	32 kW	32 kW*	32 kW*	32 kW*	36 kW*	
2.5	32 kW	32 kW	32 kW	32 kW	32 kW	32 kW	32 kW	36 kW	41 kW	41 kW	54 kW*	54 kW*	54 kW*	64 kW*	
3	32 kW	32 kW	32 kW	32 kW	32 kW	32 kW	36 kW	41 kW	54 kW	54 kW	54 kW*	64 kW*	64 kW*		
4	32 kW	32 kW	32 kW	32 kW	36 kW	41 kW	54 kW	54 kW	64 kW						
5	32 kW	32 kW	32 kW	32 kW	41 kW	54 kW	54 kW								
6	32 kW	32 kW	36 kW	54 kW	54 kW	64 kW									
7	32 kW	32 kW	41 kW	54 kW	64 kW										
8	32 kW	36 kW	54 kW	64 kW											
10	32 kW	54 kW	64 kW												
15	54 kW														
20	64 kW														
VOLTS 480 Three Phase Delta															
2.5	36 kW	36 kW	36 kW	36 kW	36 kW	36 kW	36 kW	36 kW	39 kW	48 kW	48 kW*	48 kW*	54 kW*	63 kW*	
3	36 kW	36 kW	36 kW	36 kW	36 kW	36 kW	36 kW	48 kW	48 kW	54 kW	54 kW*	63 kW*	63 kW*	72 kW*	
4	36 kW	36 kW	36 kW	36 kW	36 kW	48 kW	48 kW	54 kW	63 kW	72 kW	72 kW*	96 kW*	96 kW*	96 kW*	
5	36 kW	36 kW	36 kW	39 kW	48 kW	54 kW	63 kW	72 kW	96 kW	96 kW	96 kW*	96 kW*	108 kW*	126 kW*	
6	36 kW	36 kW	36 kW	48 kW	54 kW	63 kW	72 kW	96 kW	96 kW	108 kW	108 kW*	126 kW*	126 kW*	144 kW*	
7	36 kW	36 kW	48 kW	54 kW	63 kW	72 kW	96 kW	96 kW	108 kW	126 kW	126 kW*	144 kW*	144 kW*		
8	36 kW	36 kW	48 kW	63 kW	72 kW	96 kW	96 kW	108 kW	126 kW	144 kW	144 kW				
10	36 kW	48 kW	63 kW	96 kW	96 kW	108 kW	126 kW	144 kW							
15	48 kW	72 kW	96 kW	126 kW	144 kW										
20	63 kW	96 kW	126 kW												
23	72 kW	108 kW	144 kW												
26	96 kW	126 kW													
30	96 kW	144 kW													
VOLTS 600 Three Phase Delta															
3	61 kW	61 kW	61 kW	61 kW	61 kW	61 kW	61 kW	61 kW	61 kW						
4	61 kW	61 kW	61 kW	61 kW	61 kW	61 kW	61 kW	61 kW	61 kW						
5	61 kW	61 kW	61 kW	61 kW	61 kW	61 kW	61 kW	61 kW	61 kW	71 kW					
6	61 kW	61 kW	61 kW	61 kW	61 kW	71 kW	71 kW	102 kW							
8	61 kW	61 kW	61 kW	61 kW	71 kW	102 kW	102 kW	130 kW							
10	61 kW	61 kW	61 kW	102 kW	102 kW	130 kW	130 kW	150 kW							
15	61 kW	71 kW	102 kW	130 kW	150 kW										
20	61 kW	102 kW	130 kW	150 kW											
23	71 kW	102 kW	150 kW												
26	102 kW	130 kW													
30	102 kW	150 kW													

* S models only