

METERING SPREAD LAVATORY FAUCETS

1340.725
1340.825
1340.855
1340.865
1340.827
1340.857

Thank you for selecting American-Standard...the benchmark of fine quality for over 100 years.

To ensure that your installation proceeds smoothly—please read these instructions carefully before you begin.

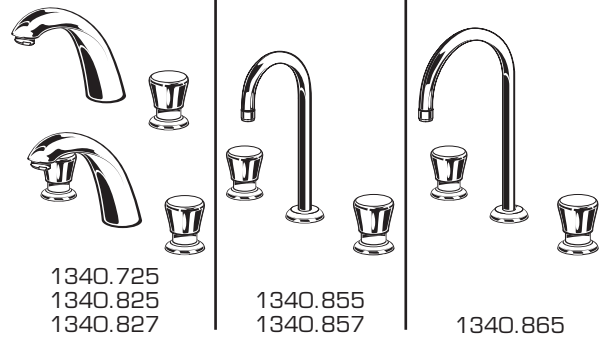

Certified to comply with ANSI A112.18.1M

M968492 Rev.1.5

Recommended tools

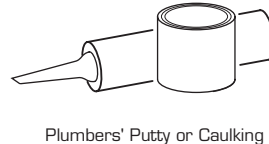
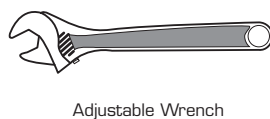
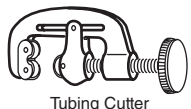

1 PREPARE TUBE AND TEE ASSEMBLY

- Remove COUPLING NUT (1) and FERRULE (2) from each VALVE (3) and slide onto TUBING (4).

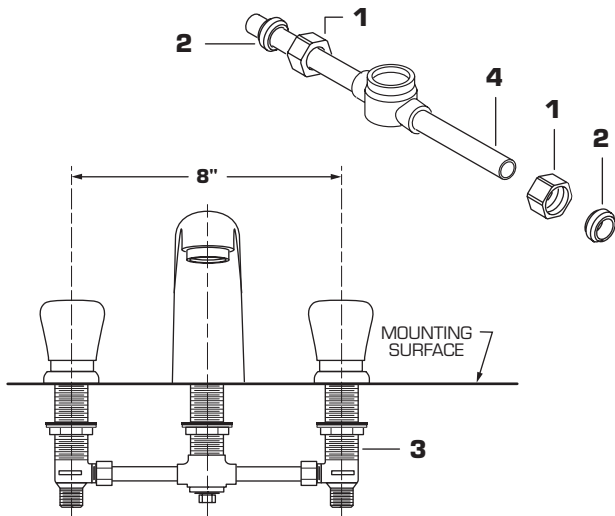

2 REMOVE HANDLE AND ACTUATOR ASSEMBLY

- Remove HANDLE (1) by removing INDEX BUTTON (2) and SET SCREW (3) with a 2.5mm hex wrench.
- Pull off HANDLE (1).
- Remove ACTUATOR ASSEMBLY (4).
- Replace WASHER (5) with new Washer (5) that is provided in separate bag.

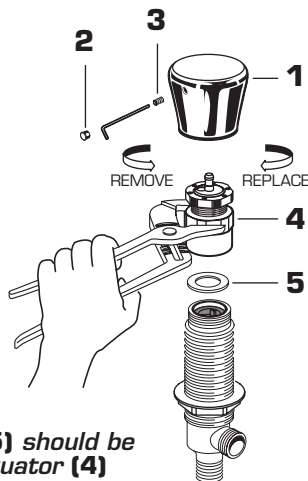

Attention; Sealing washer (5) should be replaced everytime valve actuator (4) is removed.

3 VALVE ASSEMBLY (1340.825; 1340.855; 1340.865)

- Install LOCKNUTS (1), METAL WASHERS (3) and RUBBER WASHERS (2) onto valve shanks.
- Push TUBING (12) ends into VALVE (4) side outlets. Insert VALVES (4) into mounting holes from underside of ledge.
- Thread of VALVE BODY (4) should extend at least 5/16 inch above MOUNTING SURFACE (9). If necessary, adjust LOCKNUT (1).
- Place RUBBER RING (8) into ESCUTCHEONS (7) and thread onto valves until snug against internal stop.
- Tighten LOCKNUT (1) to secure VALVE (4) position.
- Slide FERRULE (10) and COUPLING NUT (11) to outlet of VALVE (4) and tighten COUPLING NUT (11) firmly.
- Place WASHER (14) on top of VALVE ASSEMBLY (4).
- Thread VALVE ACTUATORS (13) onto VALVES (4) and torque VALVE ACTUATOR 12-15 ft. lbs, (12-20Nm).
- Connect water supply to VALVES (4) with 1/2" IPS FLEXIBLE SUPPLIES or 3/8" O.D. BULL-NOSE RISERS. Use adjustable wrench to tighten connections. Do not over tighten. Be careful not to kink copper supply when bending. Use tubing cutter to cut to proper length.

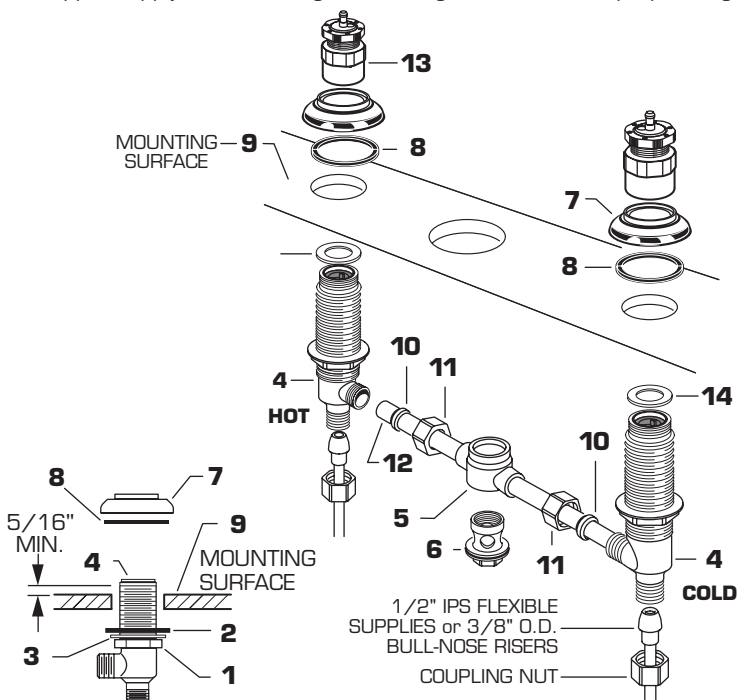

3a

VALVE ASSEMBLY (1340.725) For Cold or Tempered Water Supply

- Valve assembly is same as two handle lavatory faucets. See **Step 3** instructions for assembly, (1340.725 Single Valve Faucet) is for Cold or Tempered water only.

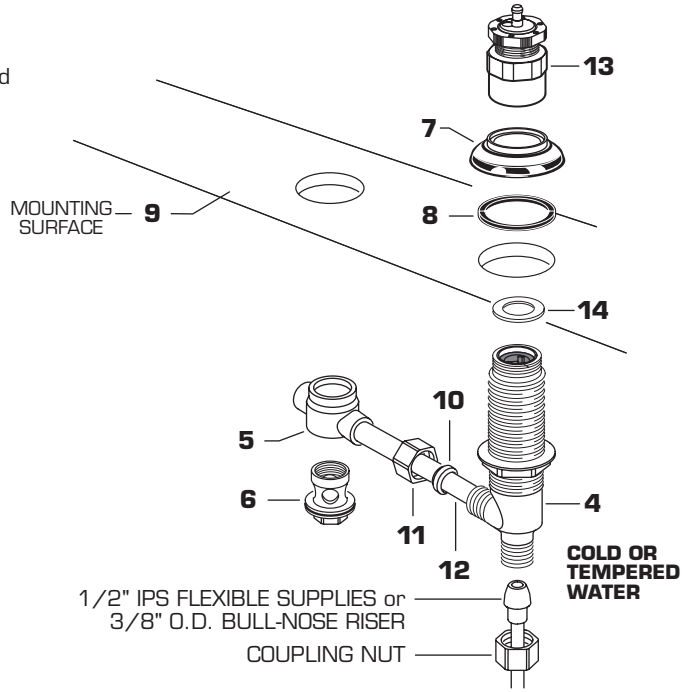
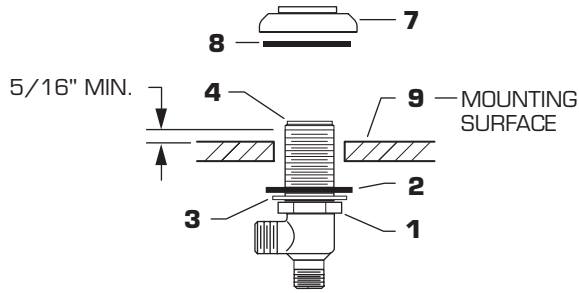

4

SPOUT ASSEMBLY

CAUTION

Turn off hot and cold water supplies before beginning.

- Install RING WASHER (1) into SPOUT (2) recess. Check that O-RING (3) on end of SPOUT SHANK (4) is in place. Insert SPOUT SHANK (4) into center hole on mounting surface.
- Assemble RUBBER WASHER (5) and BRASS WASHER (6) and LOCKNUT (7) onto SPOUT SHANK (4). Align SPOUT ASSEMBLY. From underside of ledge, tighten LOCKNUT (7) approximately halfway up the spout shank.
- Press SPOUT SHANK (4) onto TEE (8) making certain that the O-RING (3) is properly seated on SHANK (4). Push COUPLING (9) into TEE (8) and attach to SPOUT SHANK (4) and tighten. Por la parte inferior, apriete la tuerca (7) para asegurar el cuerpo a la superficie de montaje.

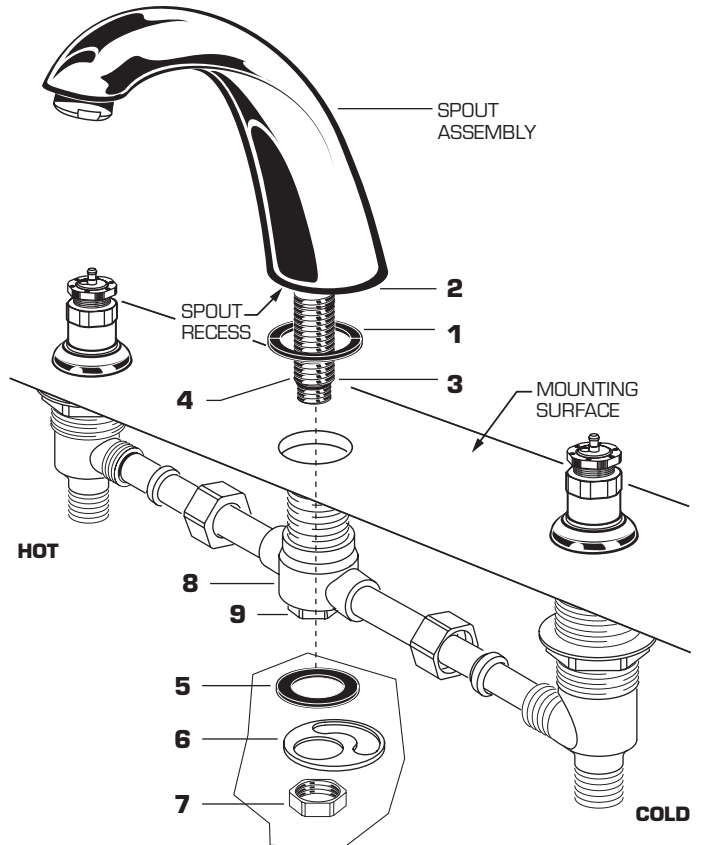

5 INSTALL HANDLES

- Remove INDEX BUTTON (1; 2) and loosen SET SCREW (3) with a 2.5mm hex wrench.
- Install HANDLES (4) onto VALVE STEM (5).
- Tighten SET SCREWS (3) with 2.5mm Hex Wrench.
- Replace INDEX BUTTONS. Red (1) in Left HANDLE (4) Blue (2) in Right HANDLE (4).

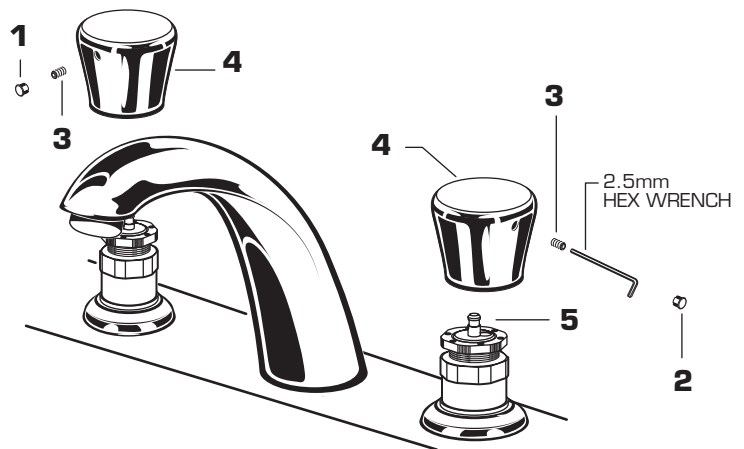

6 TEST INSTALLED FITTING

- Turn on water supplies and check connections for leaks.
- Remove AERATOR (1) with KEY (2) supplied.
- Operate HOT and COLD HANDLES by pressing down on HANDLES. Both Hot and Cold handles are set for approximately 8 second operating cycles.
- Replace AERATOR (1).

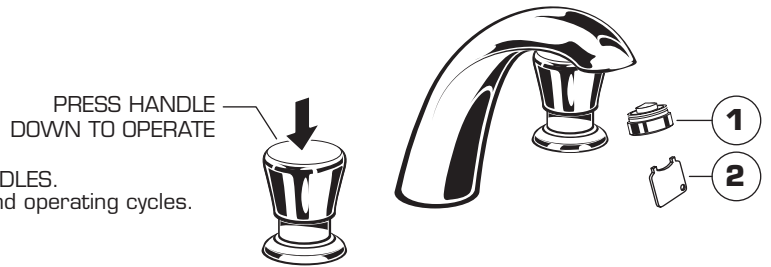

7 TO ADJUST CYCLE TIME

- Remove HANDLE (1) by removing INDEX BUTTON (2) and SET SCREW (3) with a 2.5mm hex wrench.
- Pull off HANDLE (1).
- To increase cycle time, turn the gray PLASTIC ADJUSTING KNOB (4) **clockwise**.
- To decrease cycle time, turn the gray PLASTIC ADJUSTING KNOB (4) **counter-clockwise**.
- Replace SET SCREW (3), INDEX BUTTON (2) and HANDLE (1). Test faucet for proper operation and cycle time.

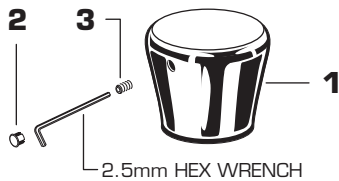

TO DECREASE CYCLE TIME ROTATE COUNTER-CLOCKWISE

TO INCREASE CYCLE TIME ROTATE CLOCKWISE

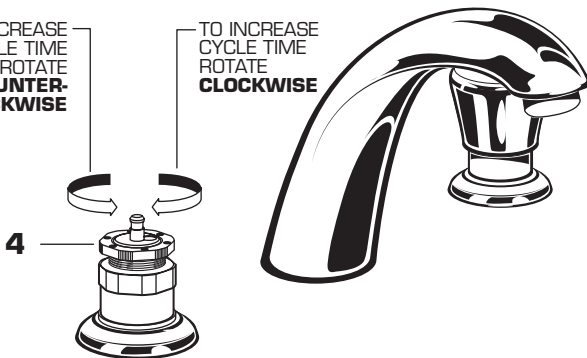

8 SERVICE

- Remove HANDLE (1). Refer to Step 3 for handle removal.
- Remove ACTUATOR ASSEMBLY (1).
- Remove WASHER (3). Pull out VALVE ASSEMBLY (4) and FILTER SCREEN (5).
- Inspect that VALVE ASSEMBLY (4), FILTER SCREEN (5) and VALVE SEAT (6) are clean and free from debris. VALVE ASSEMBLY (3) and FILTER SCREEN (5) can be cleaned with soap and water.
- Replace FILTER SCREEN (5), VALVE ASSEMBLY (4) and WASHER (3). Place WASHER (3) on top of VALVE ASSEMBLY (4). Thread VALVE ACTUATOR (2) onto faucet. Torque VALVE ACTUATOR (2) to 12-15 ft. lbs (15-20 Nm).
- Replace HANDLE (1).

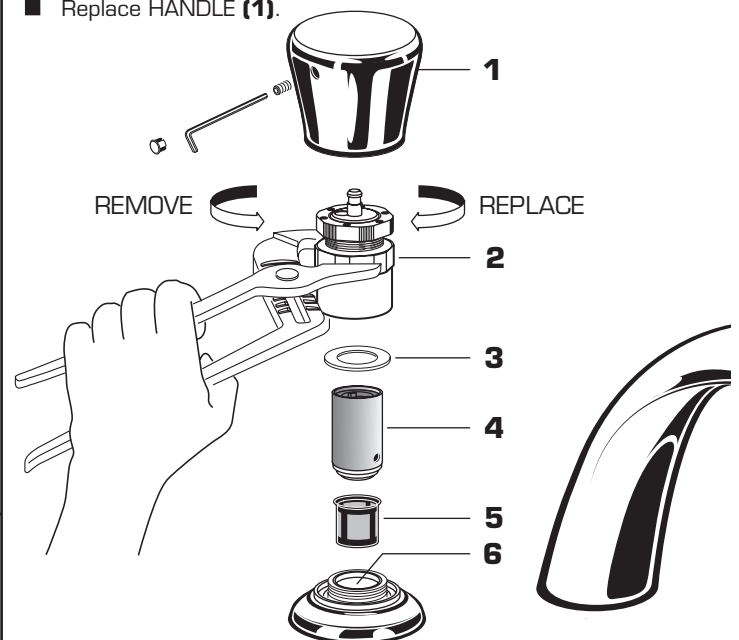

CARE INSTRUCTIONS:

DO: SIMPLY RINSE THE PRODUCT CLEAN WITH CLEAR WATER. DRY WITH A SOFT COTTON FLANNEL CLOTH.

DO NOT: CLEAN THE PRODUCT WITH SOAPS, ACID, POLISH, ABRASIVES, HARSH CLEANERS, OR A CLOTH WITH A COARSE SURFACE.

Attention; Sealing washer (3) should be replaced everytime VALVE ACTUATOR (2) is removed.