

SELECTRONIC™ PROXIMITY DUAL FLUSH TOILET FLUSH VALVE 1.6 / 1.1 GPF, 1.28/1.1 GPF



MODEL NUMBERS

6065.561
6065.761
6065.721
6065.521

Exposed Flushometer for 1-1/2" Top Spud Bowls

This flushometer valve is intended to be used with listed/certified 1.6gpf / 1.1gpf dual flush bowls only.

CLOG RESISTANT

- Self-cleaning piston valve prevents clogging and reduces maintenance.

ONE SENSOR FITS ALL

- Only 1 sensor for entire Selectronic™ line of faucets, urinals, and flush valves.
- Range can be adjusted manually or with optional remote control.
- Sensor Features Low Battery Indicator.

Certified to comply with ASME A112.19.2M
© 2010 AS America, Inc.

M965051 REV.1.5

American Standard

NOTE TO INSTALLER: Please give this manual to the customer after installation.

To learn more about American Standard Faucets visit our website at: www.americanstandard-us.com
or U.S. customer's e-mail us at: faucetsupport@americanstandard.com

For Parts, Service, Warranty or other Assistance,
please call **1-800-442-1902 (In Canada: 1-800-387-0369)**
(In Toronto Area only: 1-905-3061093)

Thank you for selecting American-Standard...the benchmark of fine quality for over 100 years. To ensure that your installation proceeds smoothly--please read these instructions carefully before you begin.

UNPACKING

All American Standard Products Are Water Tested At Our Factory. Some Residual Water May Remain In The Valve During Shipping.

1. Remove the Flush Valve items from the carton. The illustration below shows all items after they have been removed from the carton. Some items may be packaged partially assembled to other items.

- | | |
|----------------------------------|------------------------------|
| 1. Flush Valve Assembly | 5. Sweat Solder Adapter |
| 2. Down Tube and Vacuum Breaker | 6. Cover Tube |
| 3. Spud Coupling Nut and Washers | 7. Wall Escutcheon |
| 4. Spud Flange | 8. Supply Stop |
| | 9. Installation Instructions |

CARE INSTRUCTIONS:

DO: SIMPLY RINSE THE PRODUCT CLEAN WITH CLEAR WATER. DRY WITH A SOFT COTTON FLANNEL CLOTH.

DO NOT: DO NOT CLEAN THE PRODUCT WITH SOAPS, ACID, POLISH, ABRASIVES, HARSH CLEANERS, OR A CLOTH WITH A COARSE SURFACE.

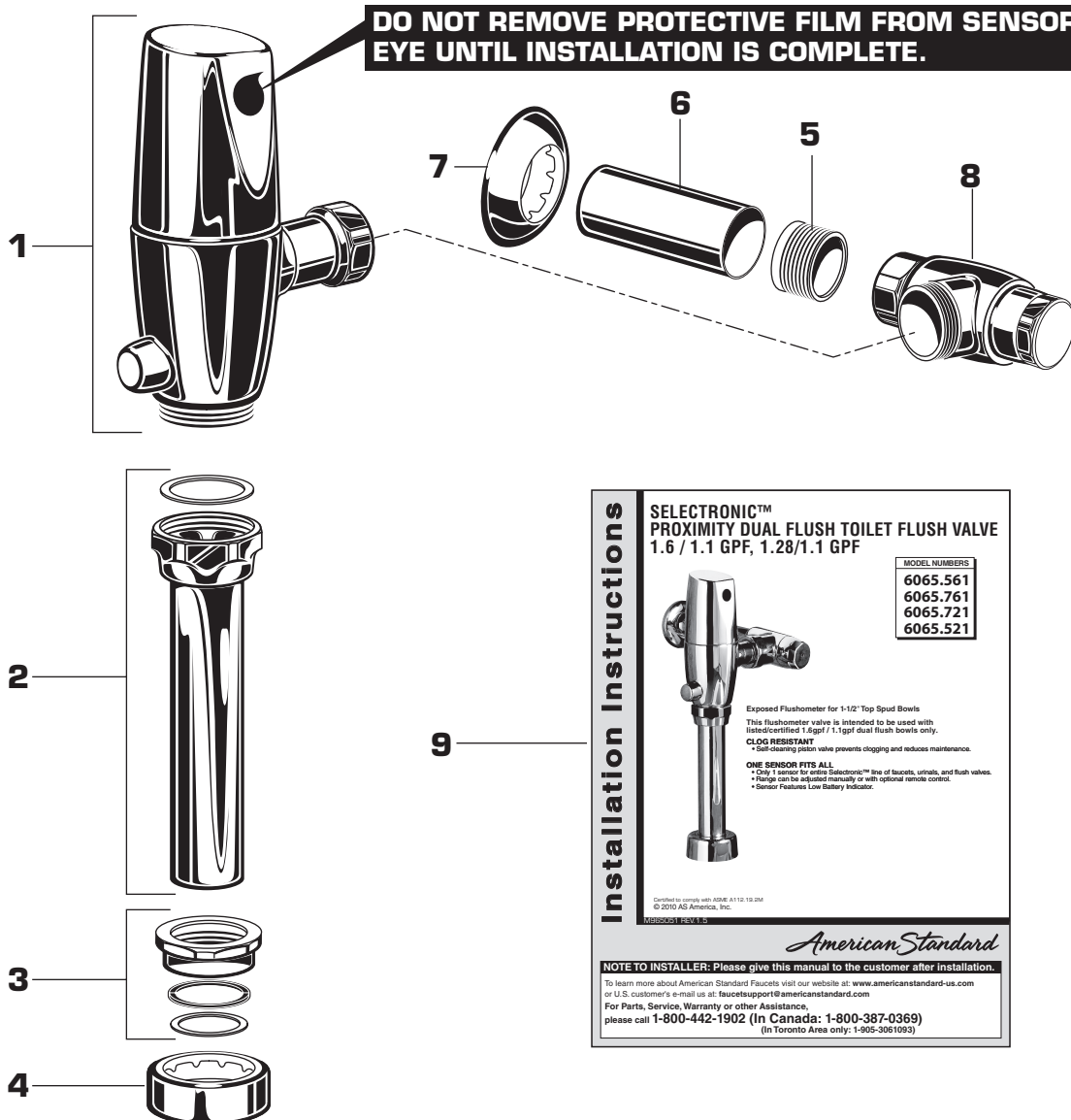

Installation Instructions

SELECTRONIC™ PROXIMITY DUAL FLUSH TOILET FLUSH VALVE
1.6 / 1.1 GPF, 1.28/1.1 GPF

MODEL NUMBERS
6065.561
6065.761
6065.721
6065.521

Exposed Flushometer for 1-1/2" Top Spud Bowls
This flushometer valve is intended to be used with listed/certified 1.6gpf/1.1gpf dual flush bowls only.

CLOG RESISTANT
• Self-cleaning piston valve prevents clogging and reduces maintenance.

ONE SENSOR FITS ALL
• Only 1 sensor for entire Selectronic™ line of faucets, urinals, and flush valves.
• Range can be adjusted manually or with optional remote control.
• Sensor Features Low Battery Indicator.

Certified to comply with ASME A112.19.2M
© 2010 AS American, Inc.
ELECTRONIC PROXIMITY

American Standard

NOTE TO INSTALLER: Please give this manual to the customer after installation.
To learn more about American Standard Faucets visit our website at: www.americanstandard-us.com
or U.S. customer's e-mail us at: faucetupport@americanstandard.com
For Parts, Service, Warranty or other Assistance,
please call 1-800-442-1902 (In Canada: 1-800-387-0369)
(In Toronto Area only: 1-905-3061093)

Fig. 1
Roughing-in Dimensions

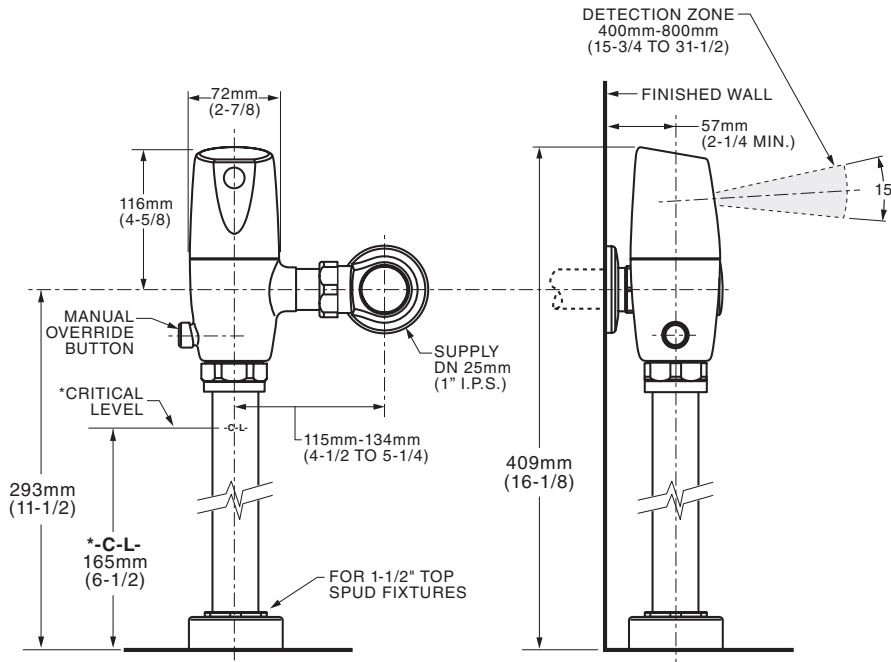

GENERAL DESCRIPTION:

**SELECTRONIC™
PROXIMITY TOILET
FLUSH VALVE**

**Exposed Flushometer
for 1-1/2" Top Spud Fixtures**

Exclusive, self cleaning piston-type flush valve with proximity operation and manual override. Operates on DC (battery) power. Recommended operating pressure 25 psi (flowing) to 80 psi (static). Can install left or right-handed. Detection Zone can also be adjusted manually, or with optional remote control.

Right or Left Hand Installation

See (Section 5) for converting Flush Valve to Left Hand Installation.

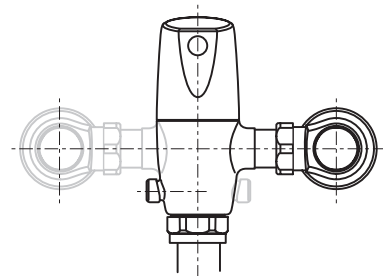

*Note: The Critical Line (-C-L-) on Vacuum Breaker must typically be 6" (152mm) above fixture. Consult Codes for details.

RECOMMENDED TOOLS; Fig. 2

1. Teflon Tape
2. Flat Blade Screwdriver
3. Adjustable Wrench
4. Tape Measure
5. Hacksaw
6. Tubing Cutter
7. File
8. For Sweat Connection; Solder and Torch
9. 2.5mm Hex Wrench
10. 1.5mm Hex Wrench

Fig. 2

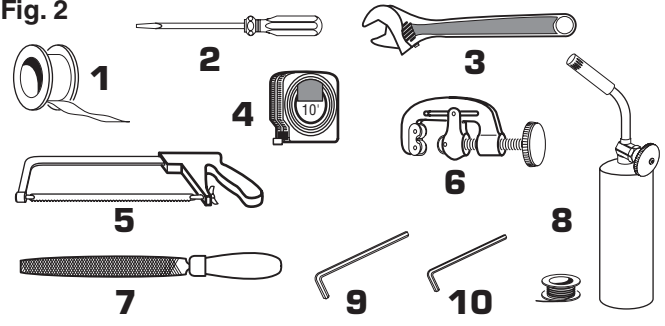

PRIOR TO INSTALLATION

Note: Prior to installing the Selectronic™ Flush Valve the following items must be installed.

1. Water Closet
2. Drain line
3. Water supply line

IMPORTANT:

- All plumbing must be installed in accordance with applicable codes and regulations.
- Water supply lines must be sized to provide an adequate volume of water for each fixture.

- Flush all water lines prior to operation (See Step 4). Dirt and debris can cause flush valve to run continuously.
- With the exception of Supply Stop Inlet, DO NOT use pipe sealant or plumbing grease on any valve component or coupling!
- Protect the chrome or special finish on the Flushometer. DO NOT USE toothed tools on finished surfaces to install or service these valves. Also see "Care and Cleaning" section of this manual.
- This product contains mechanical and/or electrical components that are subject to normal wear. These components should be checked on a regular basis and replaced as needed to maintain the valve's performance.

1 INSTALL THE SWEAT SOLDER ADAPTER; Fig. 3

CAUTION Turn water supplies off before beginning

Note: Install Optional Sweat Solder Adapter (Supplied) for copper pipe supply line. Fig. 3.

1. Measure the distance (A) from the finished wall to the center of the inlet spud on the fixture.
2. Cut the supply pipe 1-1/4" (A-B=C) shorter than the measurement taken in Step 1. File any rough edges off the end of the supply pipe.
3. Clean the end of the supply pipe. Push the threaded Adapter on until it is seated against the internal stop. Sweat the Adapter to the pipe.

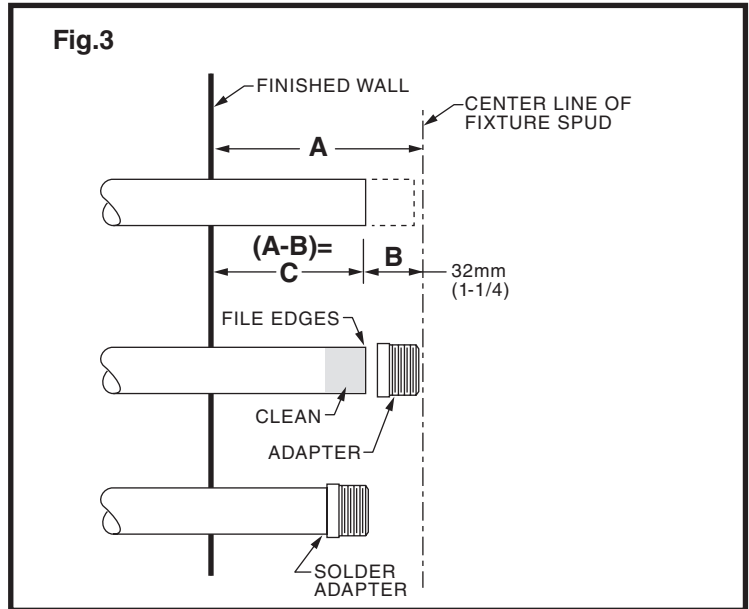

2 INSTALL COVER TUBE, WALL ESCUTCHEON and SUPPLY STOP; Fig. 4

1. Measure from finished wall to first thread of Adapter or threaded supply pipe (dimension "X"). Cut COVER TUBE (1) to length (X). Apply Teflon Tape to the threaded end of the Adapter or supply pipe. Fig. 4a.
2. Push the COVER TUBE (1) into the WALL ESCUTCHEON (2). Slide both onto the SUPPLY PIPE (3). Fig. 4b.
3. Push the COVER TUBE (1) in to expose the threads of the supply pipe. Fig. 4c. With a wrench thread the SUPPLY STOP (4) onto the SUPPLY PIPE (3). Align and tighten. Fig. 4c.
4. Pull COVER TUBE (1) against SUPPLY STOP (4) and push WALL ESCUTCHEON (2) against finished wall.

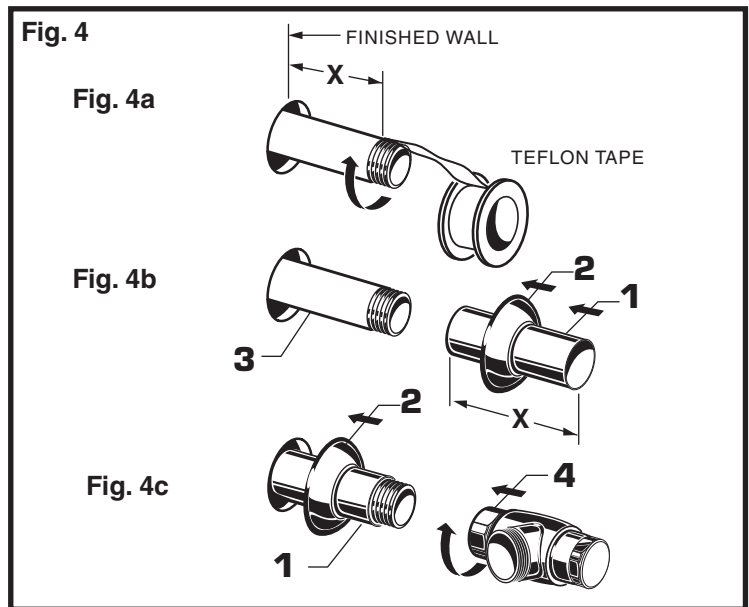

3 INSTALL DOWN TUBE AND VACUUM BREAKER; Fig. 5

1. Place the SPUD FLANGE (1) over the spud on the Fixture.
2. Thread SPUD COUPLING NUT (2) onto Spud. Make sure SEAL WASHER (3) and FRICTION WASHER (4) are installed. Do not tighten fully.
3. Insert the DOWN TUBE (5) into the SPUD COUPLING NUT (2) and push it down.

Note: If cutting Down Tube (5) to size, note that Critical Line (C/L) on Vacuum Breaker must typically be 6" (152mm) above fixture. Consult Code for details.

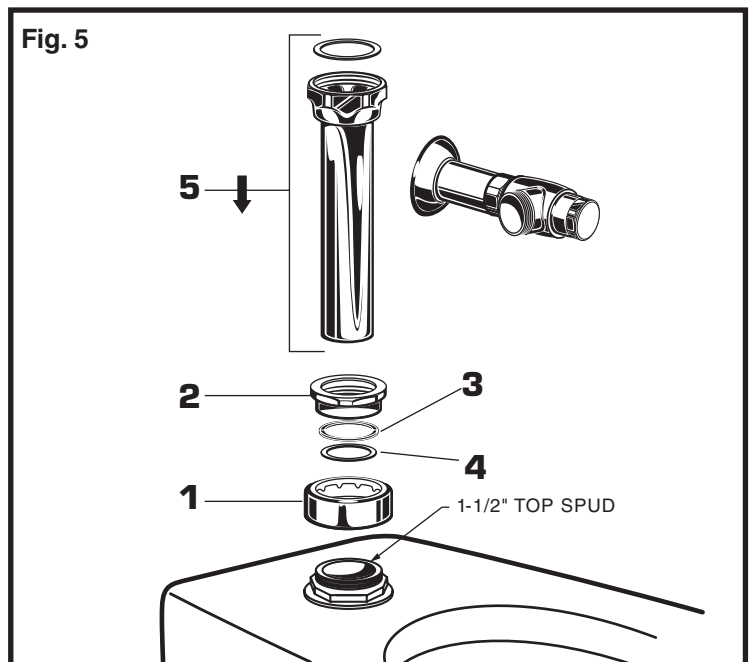

4 FLUSH OUT SUPPLY LINES; Fig. 6

1. Remove COVER (1) from SUPPLY STOP (2).
2. With a flat blade screwdriver open SUPPLY STOP (2).
3. Turn on water supply to flush line of any debris or sediment.
4. Close SUPPLY STOP (2) and replace COVER (1).

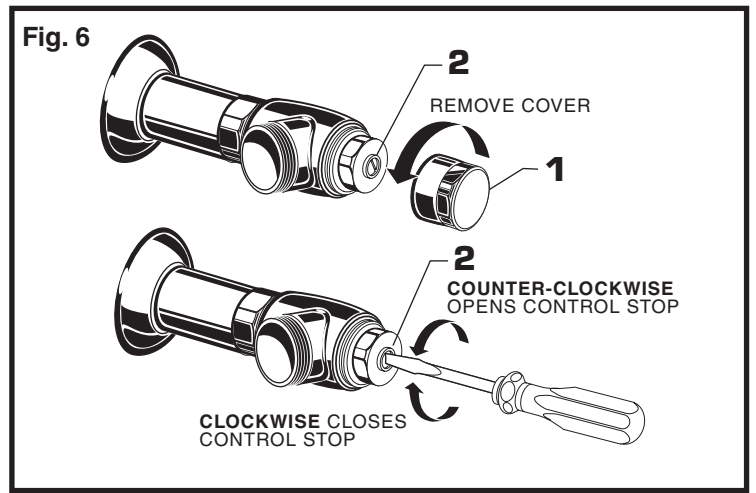

5 LEFT OR RIGHT HAND INSTALLATION; Fig. 7

The UNIT is shipped with the inlet flange on the right side. If needed, the orientation can be reversed by following the steps below.

1. Loosen SET SCREW (1) with 2.5mm Hex Wrench (4) in back of top half of FLUSH VALVE (2). Fig. 7a.
2. Rotate TOP (2) to the right and pull off. Fig. 7b.
3. Rotate bottom half of FLUSH VALVE (3) 180°. Fig. 7b.
4. Replace TOP (2) and rotate until key engages then tighten SET SCREW (1). Fig. 7c, 7d.

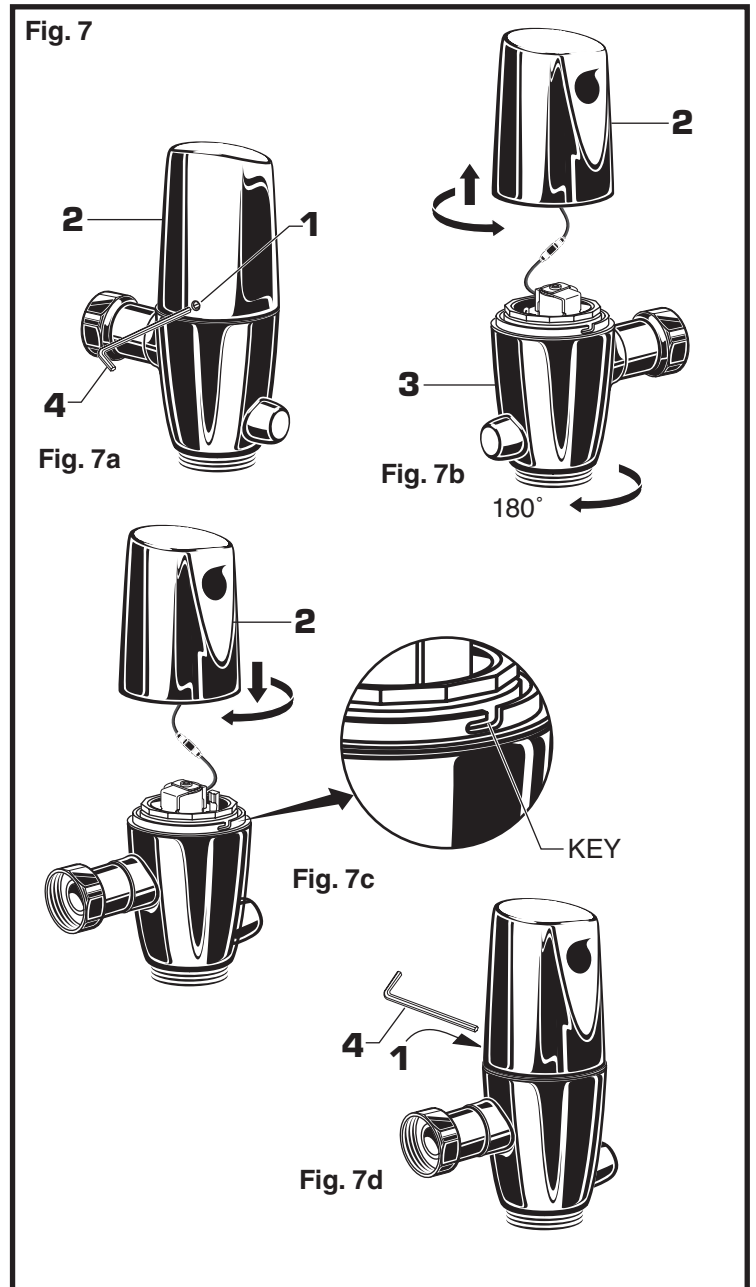

6 INSTALL FLUSH VALVE;

Fig. 8a & 8b

1. As shown in **Fig. 8a**, insert the side INLET FLANGE (1) on the FLUSH VALVE (2) into the SUPPLY STOP (3). Lubricate the INLET FLANGE O-RING (4) with water if necessary. Lightly tighten COUPLING NUT (5). **Fig. 8a. Important: Do not use lubricants (other than water) or any type of thread sealing paste or tape.**

2. Align the FLUSH VALVE (2) (**Fig. 8b**) directly above the DOWN TUBE (7) and VACUUM BREAKER COUPLING NUT (6). Make sure that GASKET (10) is installed.

Note: There is a +13mm, -6mm (+1/2, -1/4) tolerance for the 121mm (4-3/4) dimension. Fig. 8b.

3. Pull the DOWN TUBE (7) up to meet the threaded FLUSH VALVE CONNECTION (8) and hand tighten the VACUUM BREAKER COUPLING NUT (6). Align all components of the flush valve assembly. **Fig. 8b.**

4. Lightly tighten the COUPLING NUT (5) connection first, then the VACUUM BREAKER COUPLING NUT (6) and finally the SPUD COUPLING NUT (9). Once aligned correctly, use a wrench to tighten couplings to make water tight connections. **Fig. 8b.**

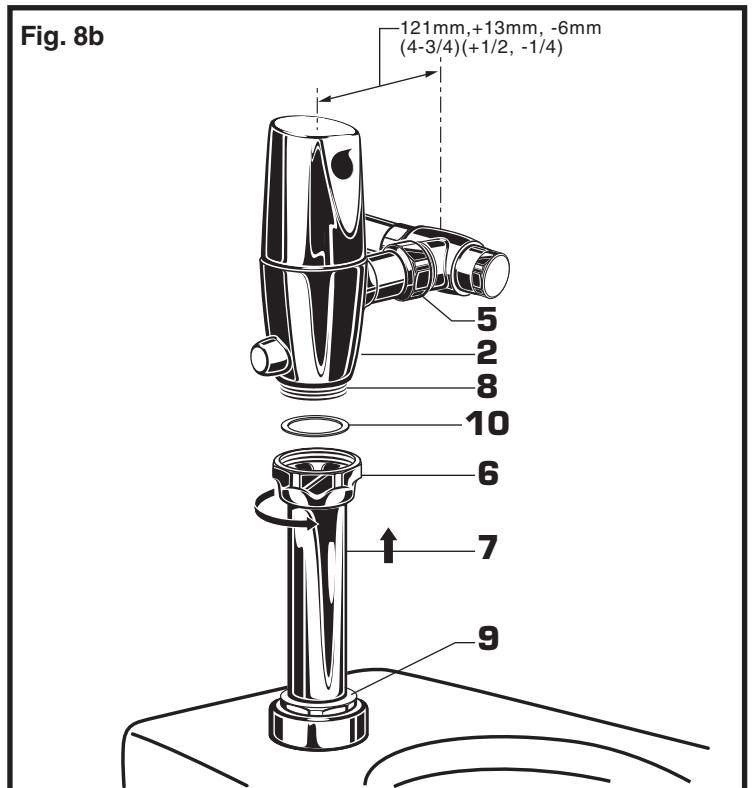
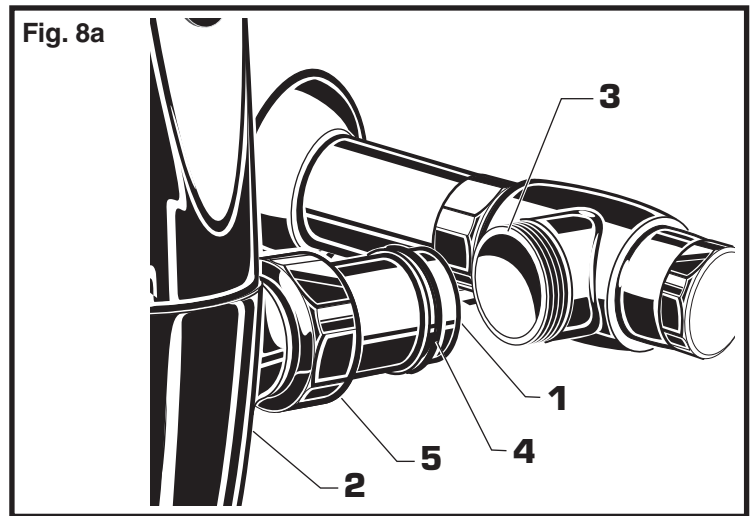

7 ADJUST SUPPLY STOP; Fig. 9

IMPORTANT: To avoid overflowing, the SUPPLY STOP (3) must never be opened to the point where the flow from the valve exceeds the flow capacity of the fixture. The fixture must be able to handle a continuous flow in case of a flush valve failure.

1. After installation is complete, peel off the PROTECTIVE FILM (1) from the sensor. Standing to one side, block the sensor with your hand for 10 seconds. **Remove your hand and listen for audible "click" from within the valve.**

2. Remove COVER (2) from SUPPLY STOP (3). Turn on water supply 1/4 turn to 1/2 turn (CCW) and test for leaks. **Note: Unit may flush for approximately 5 to 10 sec. when water is first turned on. If flow persists, turn water off and repeat step #1 above.**

3. Actuate the FLUSH VALVE:
A) Cover sensor with hand for 10 seconds.
NOTE: Stand outside of sensor detection area.
B) Remove hand from in front of the sensor; unit will flush in approximately 3 seconds.

4. Adjust SUPPLY STOP (3) after each flush until the stated flush volume is achieved, no splashing occurs and the fixture is properly cleansed.

5. When adjustment is complete, replace COVER (2) and tighten to ensure vandal-resistance.

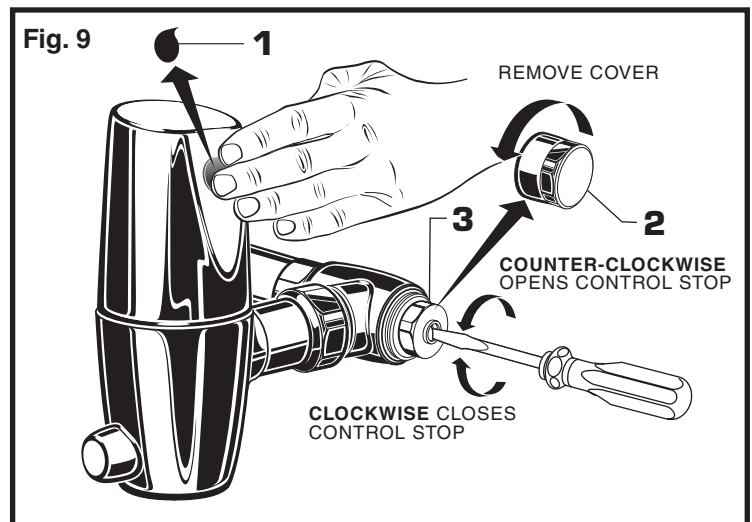

8 HOW TO RETROFIT OUR VALVE;

Fig. 10

(Replaces Industry Standard Manual and Electronic Valves)

Note: In most Retrofits the wall escutcheon, supply stop, cover tube and vacuum breaker do not have to be replaced. If these items do need replacement they must be purchased separately or order the complete flush valve assembly from American Standard.

1. Remove COVER (1) from SUPPLY STOP (2) if installed. Fig. 10.

2. Turn water supply off. Fig. 10.

3. Loosen SPUD COUPLING NUT (3). Unthread COUPLING NUT (4) and VACUUM BREAKER COUPLING NUT (5). Remove FLUSH VALVE (6). Fig. 10.

4. Clean all threaded connections before installing the new flush valve. Fig. 10a.

5. Refer to Sections 5,6 and 7 to complete the retrofit installation. Fig. 10b.

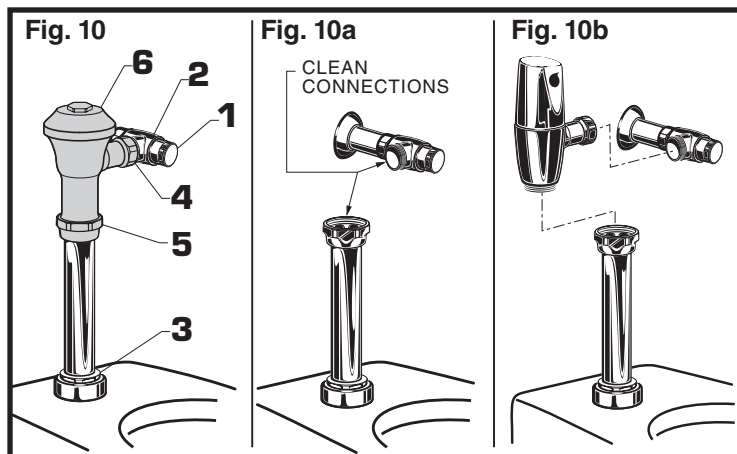

9 HOW TO CHANGE THE BATTERY;

(purchased after May 2013) Fig. 11

1. Loosen SET SCREW (1) with 2.5mm Hex Wrench (2) in back of top half of FLUSH VALVE CAP (3). Fig. 11a.

2. Rotate CAP (3) to the right and pull off. Fig. 11b.

3. Turn CAP (3) over and disconnect the SENSOR (4) from the BATTERY CABLE (5). Remove the BATTERY HOLDER (6) with BATTERY (7). Fig. 11c.

4. Remove old BATTERY (7). Install the new BATTERY (8) making sure the shape of the BATTERY (8) follows the shape of the BATTERY HOLDER (6). Fig. 11d.

5. Insert the BATTERY HOLDER (6) with BATTERY (8) into FLUSH VALVE CAP (3). Make sure the flat side of the BATTERY HOLDER (6) is facing towards the back of the FLUSH VALVE CAP (3). Reverse the above steps to assemble flush valve. Fig. 11d.

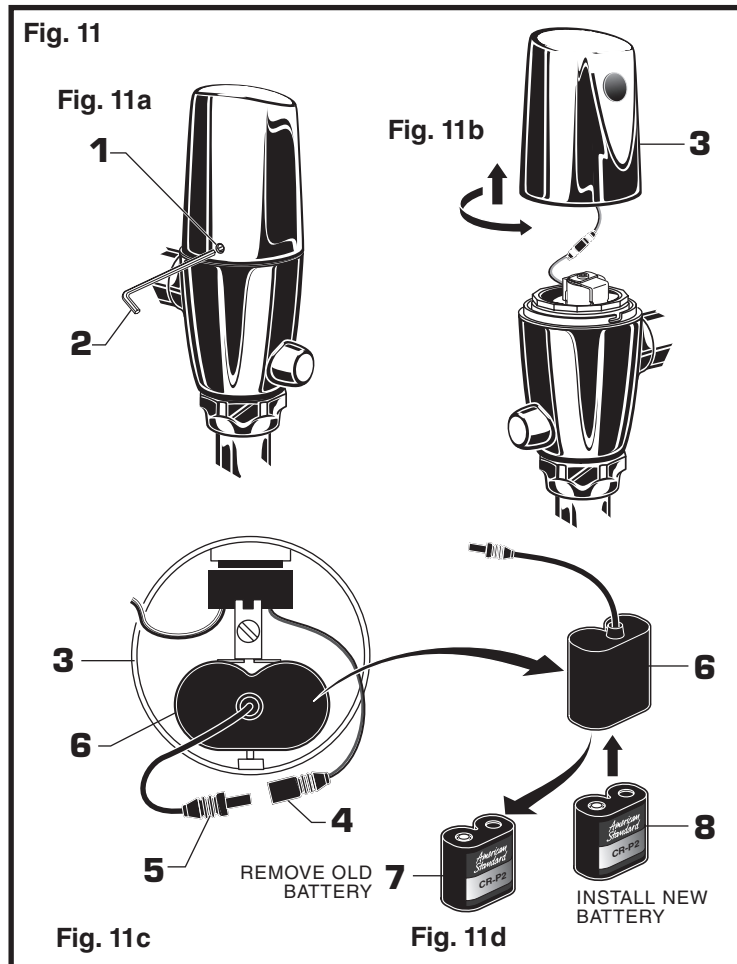

9a HOW TO CHANGE THE BATTERY;

(purchased before June 2013) Fig. 12

1. Remove CAP (3). Refer to Step 9 above. Fig. 11a.

2. Turn CAP (3) over and remove the two SCREWS (9). Remove the BATTERY COVER (10) to expose the battery (6a). Fig. 12a.

3. Remove old BATTERY (6a). Install the new BATTERY (7a) making sure the + & - are facing up towards the open end of the cover. Fig. 12b.

4. Replace the BATTERY COVER (10) reverse the above steps to assemble flush valve.

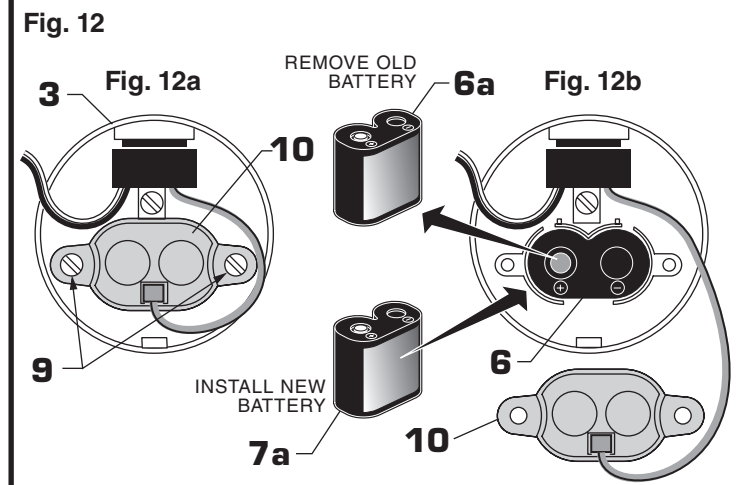

10 HOW TO SET DETECTION RANGE (If Required); (purchased after May 2013) Fig. 13 & 14

Note: The detection distance is preset and is ideal for most installations. Should an adjustment be required follow the steps below.

1. Loosen SET SCREW (1) with 2.5mm Hex Wrench (2) in back of top half of FLUSH VALVE (3). Fig. 13a.
2. Rotate CAP (3) to the right and pull off. Fig. 13b.
3. Turn CAP (3) over and disconnect SENSOR CABLE (4) from BATTERY HOLDER (5). Fig. 13c.
4. Keeping hands away from the front of the sensor, reconnect the SENSOR CABLE (4) and quickly place the CAP (3) on the valve. Do not secure the CAP (3) at this time. **Note: You have 5 seconds after connecting cable to enter program code.**
5. While the SENSOR CONTROL LED (6) is blinking slowly, place your hand 1 to 2 in. (30-50mm.) in front of the sensor. Fig. 14a.
6. When the LED (6) stops blinking and stays "ON", move your hand to the desired position from sensor (detection zone, 1-1/2" to 31", 38 to 787mm) and hold in place until the LED (6) begins to blink again. Fig. 14b. **Note: Detection Zone is 1-1/2" to 31", 38 to 787mm from sensor.**
7. Once the SENSOR CONTROL LED (6) begins to blink again, remove your hand from the detection zone. When the flashing stops, the detection distance is set.
8. Replace and secure CAP (3) onto valve.
9. Actuate the FLUSH VALVE:
 - A) Cover sensor with hand for 10 seconds. **NOTE: Stand outside of sensor detection area.**
 - B) Remove hand from in front of the sensor; unit will flush in approximately 3 seconds.

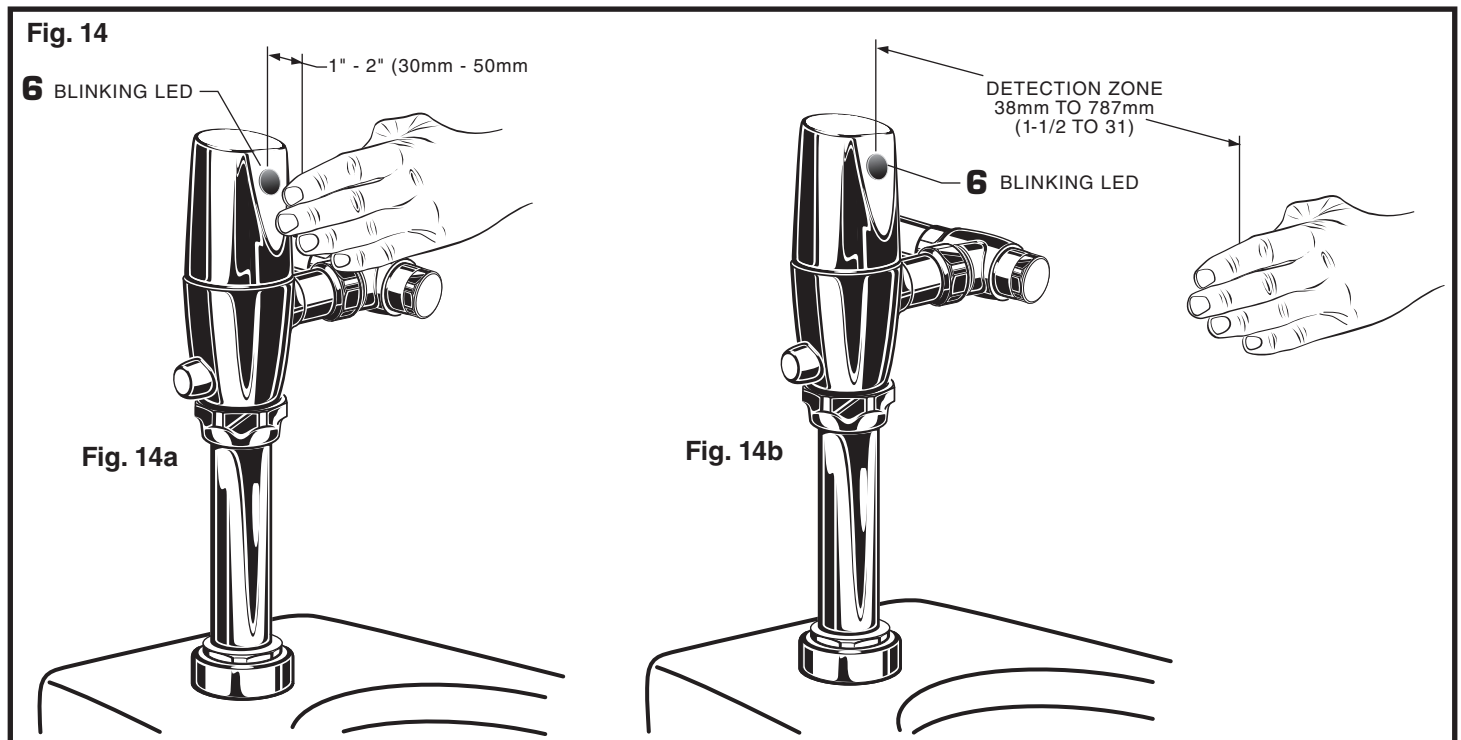
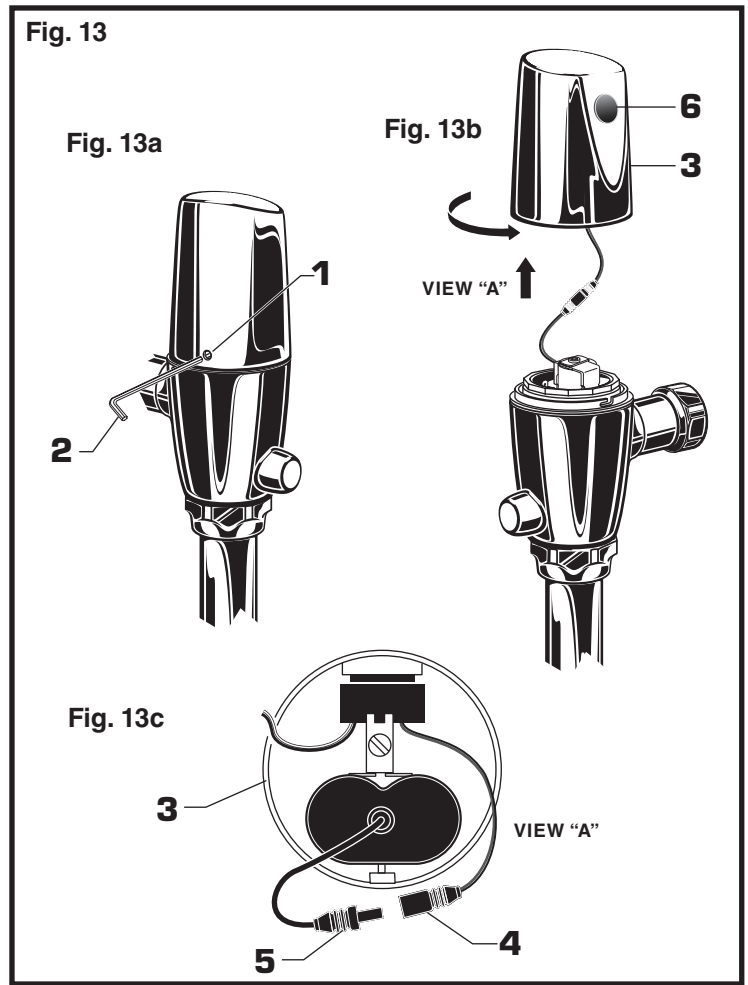

10a HOW TO SET DETECTION RANGE (If Required) ; (purchased before June 2013)

Fig. 15 & 16

Note: The detection distance is preset and is ideal for most installations. Should an adjustment be required follow the steps below.

1. Loosen SET SCREW (1) with 2.5mm Hex Wrench (2) in back of top half of FLUSH VALVE (3). Fig. 15a.
2. Rotate CAP (3) to the right and pull off. Fig. 15b.
3. Turn CAP (3) over and disconnect GREY SENSOR WIRE (4) from BATTERY COVER (5). Fig. 15c.
4. Keeping hands away from the front of the sensor, reconnect the GREY SENSOR WIRE (4) and quickly place the CAP (3) on the valve. Do not secure the CAP (3) at this time. **Note: You have 5 seconds after connecting cable to enter program code.**
5. While the SENSOR CONTROL LED (6) is blinking slowly, place your hand 1 to 2 in. (30-50mm.) in front of the sensor. Fig. 16a.
6. When the LED (6) stops blinking and stays "ON", move your hand to the desired position from sensor (detection zone, 1-1/2" to 31", 38 to 787mm) and hold in place until the LED (6) begins to blink again. Fig. 16b. **Note: Detection Zone is 1-1/2" to 31", 38 to 787mm from sensor.**
7. Once the SENSOR CONTROL LED (6) begins to blink again, remove your hand from the detection zone. When the flashing stops, the detection distance is set.
8. Replace and secure CAP (3) onto valve.
9. Actuate the FLUSH VALVE:
 - A) Cover sensor with hand for 10 seconds. **NOTE: Stand outside of sensor detection area.**
 - B) Remove hand from in front of the sensor; unit will flush in approximately 3 seconds.

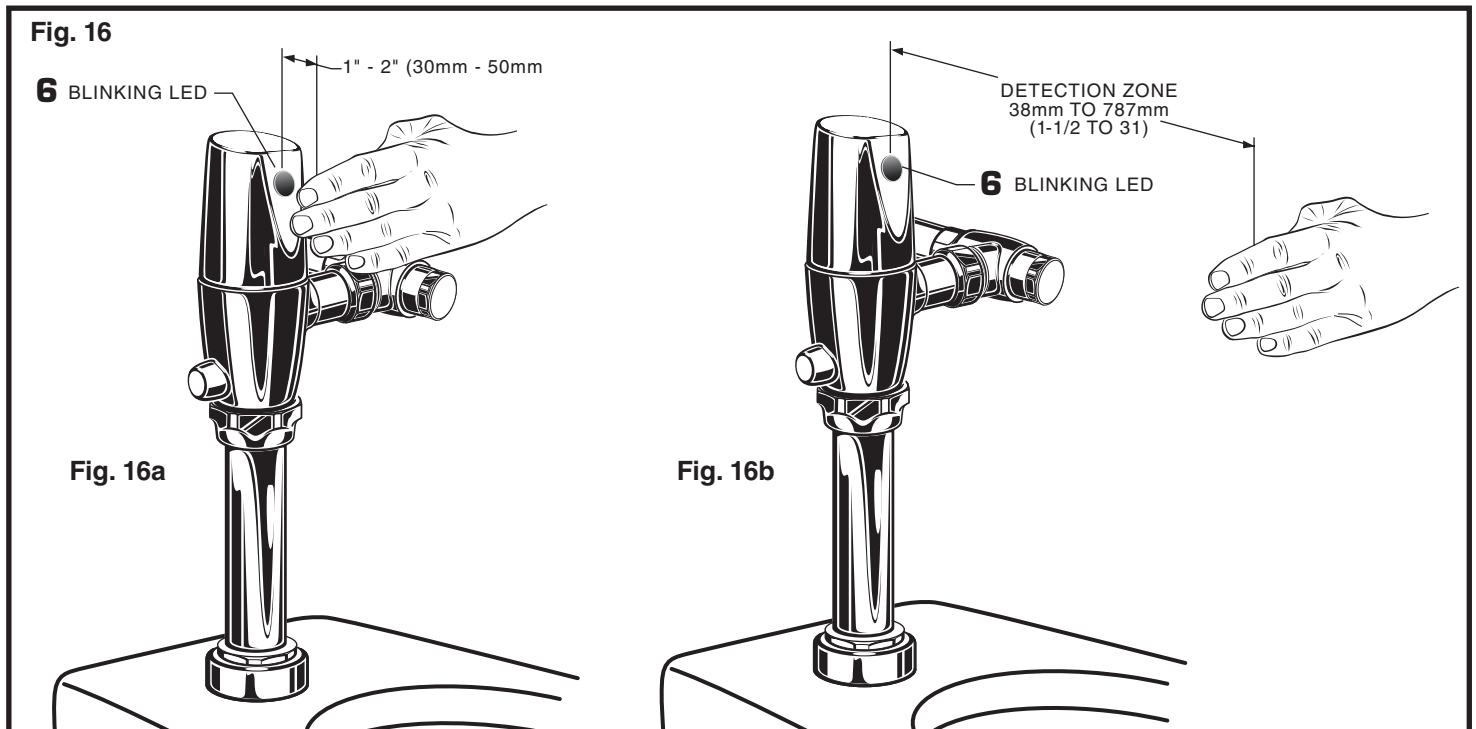
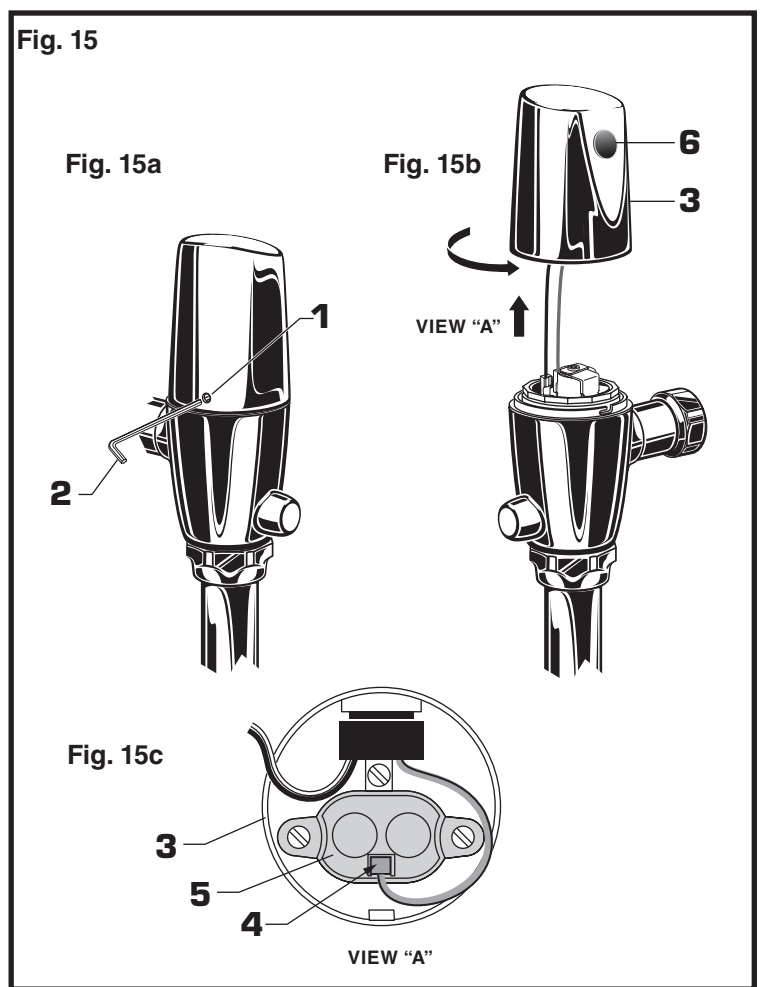

UNIT DOES NOT FLUSH AT ALL



UNIT IS CONTINUOUSLY FLUSHING

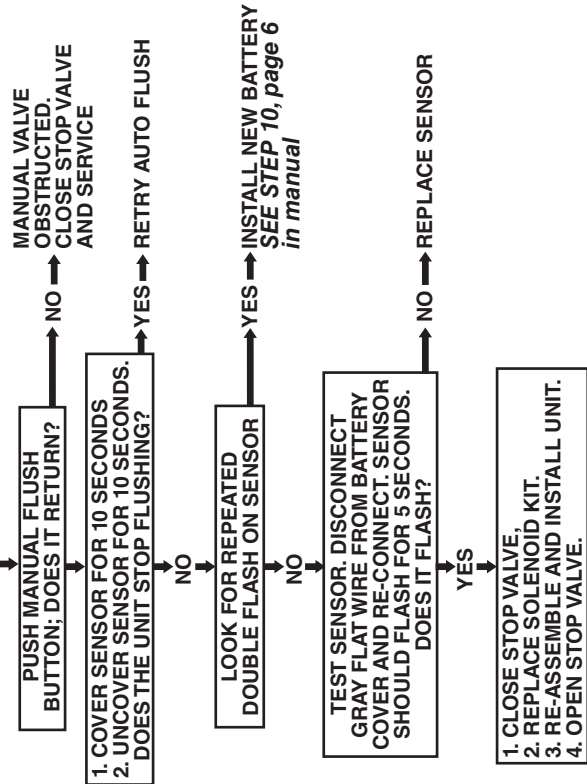

UNIT WILL ONLY FLUSH MANUALLY

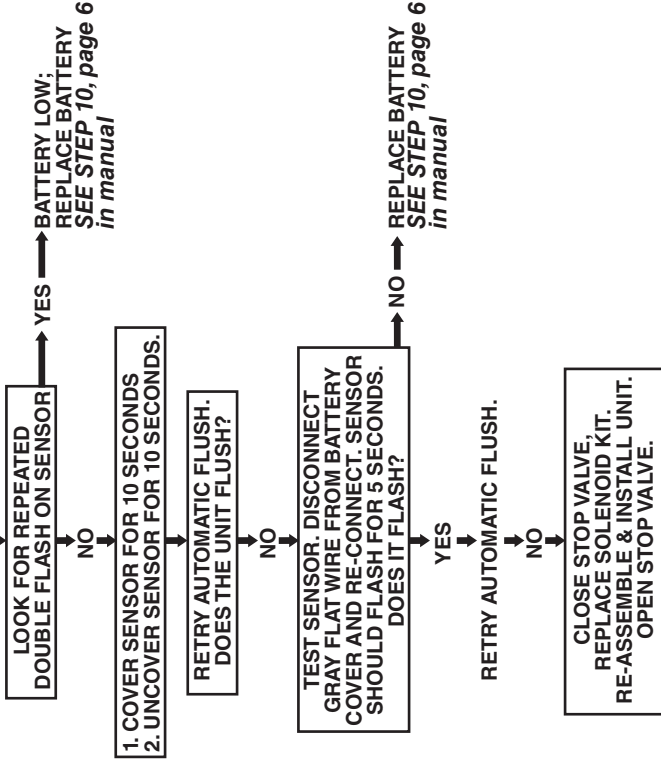

TROUBLESHOOTING FLOW CHARTS



HOT LINE FOR HELP
For toll-free information and answers to your questions, call:
1 (800) 442-1902

Weekdays 8:00 a.m. to 6:00 p.m. EST
IN MEXICO 01-800-839-1200

IN CANADA 1-800-387-0369 (TORONTO 1-905-306-1093)
Weekdays 8:00 a.m. to 7:00 p.m. EST

Product names listed herein are trademarks of AS America, Inc.