

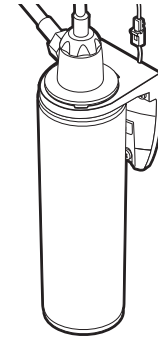

Buy it for looks. Buy it for life.®

Specifications



MOEN®

Under Sink Water Filtration System

Models: S5500

FILTRATION DESCRIPTION

- 1/2" IPS connections
 - Includes adapters to connect to a primary faucet with 1/2" IPS connections or 3/8" compression connections
- Carbon block filter technology
- Electronic filter life indicator takes standard 2032 watch battery (included)
- Compatible with S5510, S5520, and S5530 series beverage faucets

OPERATION

Operating Specification

- Capacity: ChoiceFlo™ 9500/9600 Filter certified for up to 750 gallons (2,839 L)
- Pressure requirements: 20-125 psi (0.7-8.6 bar), non shock
- Temperature: 35-100°F (2-38°C)

FLOW

- Filtered flow is limited to 0.7 gpm

STANDARDS

Filter:

- ChoiceFlo™ 9600
- Complies with NSF/ANSI Standard 42 for the reduction of chlorine, taste and odor

WARRANTY

Filter:

- 30 day limited warranty on manufacturer's defects to the original consumer purchaser

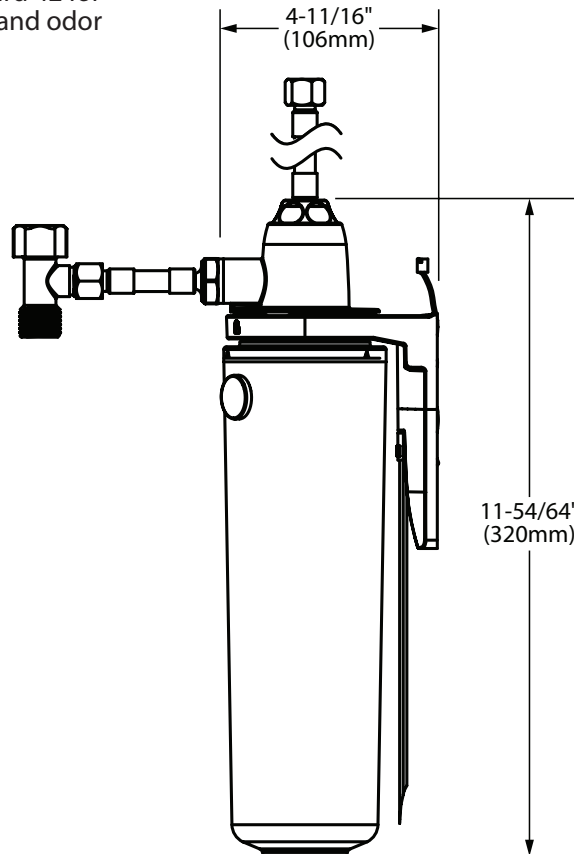

CRITICAL DIMENSIONS

(DO NOT SCALE)