



## Wall Control Transmitter Installation & Operating Instructions

370012

**CAUTION:** Before proceeding, turn the power OFF at the main circuit box by turning the breaker switch off or removing a fuse.

**WARNING:** If this control is used with a ceiling fan equipped with a manual "Pull Chain" to control fan speeds, THE PULL CHAIN CONTROL MUST BE SET TO AND LEFT ON HIGH SPEED. Failure to follow this warning could damage your ceiling fan motor and void your warranty.

**NOTE:** Included are three (3) sets of decorative switch and wall plate covers to choose from. Select the finish that matches your decor.

This accessory ceiling fan control consist of a "Radio Frequency Transmitter" ONLY. It is intended to work in conjunction with or replace our Kichler® CoolTouch™ transmitter. To operate, this transmitter requires the remote control receiver unit that came with your Kichler® ceiling fan

**NOTE:** Power for this unit is supplied by a 12 volt battery (Duracell MN21 or Eveready A23). It is NOT wired to the 120 volt household current.

### INSTALLATION

1. Remove the existing wall plate and the old switch from the wall outlet box. Wire nut the BLACK leads (hot) together and push them back inside the outlet box. (Fig. 1)
  2. Attach the transmitter unit to the outlet box using two machine screws provided. (Fig. 2)
  3. Select two screws with colored heads to match the finish of the decorative plate and attache the decorative wall plate to the transmitter. (Fig. 2)
  4. Using a dime or your finger nail at the top or bottom, remove the decorative switch plate. Insert the 12 volt battery, noting the correct direction for + and - (Fig. 3).
  5. The position, (either up or down) of the frequency switches (dip switches) on the transmitter control the operational radio frequency and MUST match, in the same order, the switches on the receiver unit. See Figure 4. Any combination of settings is fine as long as the transmitter and receiver are set in EXACTLY the same order.
- You can control "Multiple" fans with a single transmitter as long as each receiver unit is set to the same frequency as the transmitter and the transmitter is within 30 feet of each fan.
- You can control a "Single" fan with multiple transmitters as long as each transmitter is set to the same frequency as the receiver on the fan and the fan is within 30 feet of ALL transmitters.
6. After setting the frequency and installing the battery, replace the decorative switch cover by aligning the buttons with the holes and pressing back into place

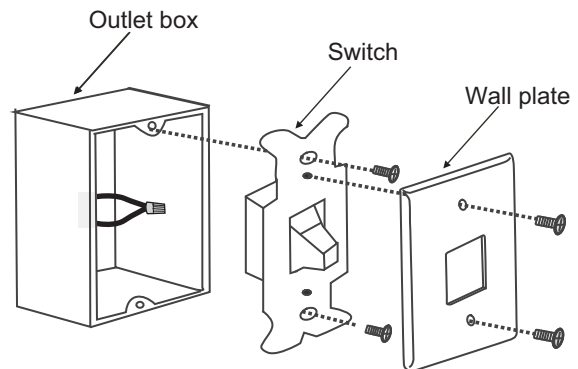

Figure 1

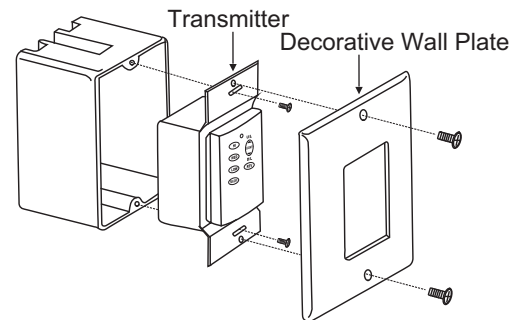

Figure 2

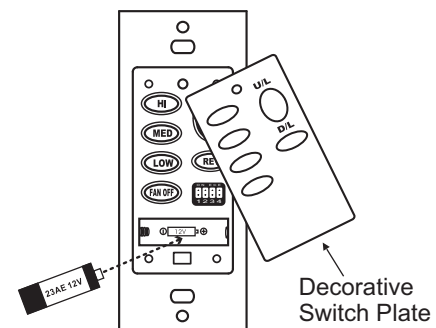

Figure 3

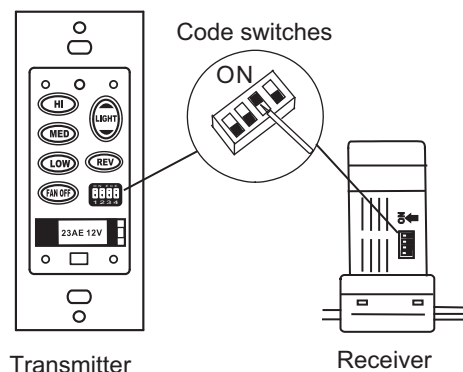
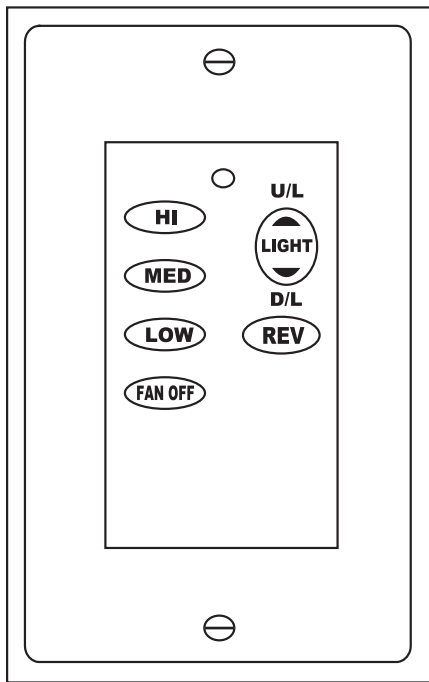

Figure 4



**Figure 5**

## OPERATING YOUR TRANSMITTER

Restore power to the ceiling fan and test for proper operation.

- Speed Buttons: These three buttons are used to set each fan speed separately. "Push and Release" for operation.

HI = High Speed  
 MED = Medium Speed  
 LOW = Low Speed

- FAN OFF Button: This button shuts off the ceiling fan motor regardless of the current speed setting. "Push & Release" for operation.

- U/L Button: This button is a "Rocker" button controlling BOTH the Upper Light (U) and the Lower Light (L), if your ceiling fan is equipped with either or both lights.

For Operation: Top of the button controls the UPPER light, Bottom of the button controls the LOWER light.

Push & Release for On/Off

Push & Hold to Dim (release when desired brightness level is reached)

Once a brightness level is set, when you turn the light off and then back on, it will return to the previous brightness level. **UNLESS POWER HAS BEEN LOST TO THE CEILING FAN DURING THE OFF INTERVAL.**

- REV Button: This button controls the direction of the fan blades. To operate, Push & Release (while the fan is running) to reverse the current blade direction.

## TROUBLESHOOTING GUIDE

If the Ceiling Fan and or light fixture(s) fail to respond to commands from the transmitter, check the following.

- Check main power supply and reset or turn on breaker
- Make sure the "Receiver Unit" is wired properly. Refer to the installations instructions for the receiver as needed.
- Manual Pull Chain speed control set on HIGH ?
- Light Fixture pull chain switch turned on ?
- Good battery in transmitter ? Replace if needed.
- Transmitter and Receiver "frequency" set the same ?

**NOTE:** The distance between the transmitter and receiver should not be greater than 30 feet. For best performance, make sure the Black Antenna on the end of the receiver unit remains extended and not tangled with any of the electrical wires.