

**LOW LEAD COMPLIANT
 2 PC 400 WOG w/COMPRESSION ENDS**

Features:

- 400 WOG
- 150 PSI WSP (366°F)
- Standard Port
- NSF 61 Annex G Certified (Annex G references NSF 372)
- Forged Brass Body & End Cap
- Blow-out Proof Stem
- Adjustable Packing
- Compression Ends
- Drain with Cap

NOT FOR USE AT OR BELOW GROUND LEVEL



NSF 61 ANNEX G



Low Lead Compliant: Referring to laws defining "Lead Free" as wetted surface of pipe, fittings and fixtures in potable water systems that have a weighted average lead content $\leq 0.25\%$ per the Safe Drinking Water Act (Sec. 1417) amended 1-4-2011 as well as other state regulations.



Constructed with a low lead forged brass body and end cap and with brass compression nuts, the FNW figure X480A compression end ball valve can be used for potable water service in residential, commercial, and industrial applications that require low lead content. Applications also include other liquids and saturated steam service to 150 PSI (366°F). The compression ends reduce installation time and eliminate possible seat damage compared to solder end valves. They are equally easy to uninstall for repair or replacement purposes.

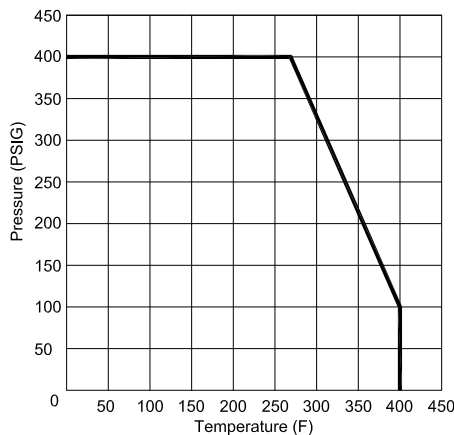

Cv & Weights

Size	Cv	Wt. (Lbs)
1/2	8	0.57
3/4	20	0.84
1	26	1.48

Figure Number Matrix

FNW X480A Size
SIZE CODE
1/2 = D
3/4 = F
1 = G

LOW LEAD COMPLIANT 2 PC 400 WOG w/COMPRESSION ENDS

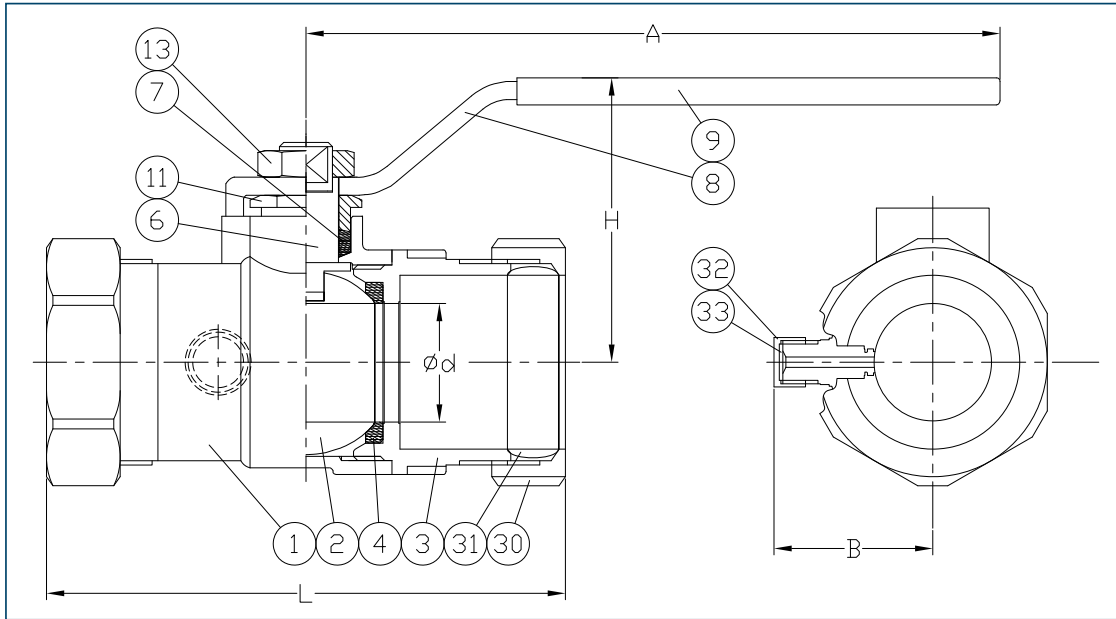

Dimensions (inches)

Size	Ød	B	A	L	H
1/2	0.39	0.83	3.15	2.76	1.46
3/4	0.59	0.98	3.15	2.99	1.57
1	.75	1.10	4.33	3.62	1.85

Standard Materials

Ref. No.	Description	Material	Qty
1	Body	Lead Free Brass, C46400	1
2	Ball	Lead Free Brass, C46400 (Chrome Plated)	1
3	End Cap	Lead Free Brass, C46400	1
4	Seat	PTFE	2
6	Stem	Brass, ASTM B16 C36000	1
7	Stem Packing	PTFE	1 Set
8	Handle	Steel, ASTM A283-D	1
9	Sleeve	Plastic, Vinyl	1
11	Packing Gland	Brass, ASTM B16 C36000	1
13	Handle Nut	Steel, AISI 1010	1
30	Compression Nut	Brass, ASTM B124 C37700	2
31	Compression Ring	Brass, ASTM B135 C26000	2
32	Drain Cap	Brass, ASTM B16 C36000	1
33	Drain Cap Seal	Rubber, NBR	1

DOC: FNWX480A Ver. 2/2014

© 2014 - FNW. All rights reserved.

The FNW logo is a trademark of Ferguson Enterprises, Inc., PL Sourcing, PO Box 2778, Newport News, VA 23609

The contents of this publication are presented for information purposes only, and while effort has been made to ensure their accuracy, they are not to be construed as warranties or guarantees, expressed or implied, regarding the products or services described herein or their use or applicability. All sales are governed by our terms and conditions, which are available on request. We reserve the right to modify or improve the designs or specifications of our products at any time without notice. Always verify that you have the most recent product specifications or other documentation prior to the installation of these products.