

## SPECIFICATIONS

# FIGURE 415LL

## BRASS BODY BALL VALVES



### 2-PC FULL PORT\* 600 WOG LEVER LOCK BALL VALVE

#### FEATURES

- 600 WOG non-shock
- 400 psi maximum for FM-approved applications
- 150 WSP
- Full port\*
- Threaded NPT ends (ANSI B1.20.1)
- Forged brass body and endcap
- 100% electronically tested in open and closed position at 80 psi
- Meets MSS SP-110 standards
- FM & CSA approved (1/2"–2")
- Blow-out proof stem
- Dual O-ring non-adjustable packing\*\*
- Accessories (sold separately)
  - Lock lever kit (1/4"–4")
  - Stem extension kit (1/4"–4")
  - Tee handle kit (1/4"–1")
  - Oval handle kit (1/4"–2")
  - Memory stop kit (1/4"–2")
  - Stainless handle (1/4"–2")

\* 4" valve is standard port

\*\* 1/4" and 3/8" utilize one o-ring, one packing ring and adjustable packing nut

NOT FOR USE AT OR BELOW GROUND LEVEL

#### WARNING

This product contains lead or lead compounds known to the State of California to cause cancer and birth defects and other reproductive harm. **Do not use in connection with drinking water.**

#### Gas Approvals

- CSA Class 3371-08, ANSI Z21.15/CSA9.1, 1/2 PSIG, -40°F–149°F
- CSA Class 3371-10, CGA 3.16, 125 PSIG, -40°F–149°F
- CSA Class 3371-12, CR91-002, 2 & 5 PSIG, -40°F–149°F
- CSA Class 3371-88, ANSI Z21.15/CSA9.1, 1/2 PSIG, -40°F–149°F
- CSA Class 3371-90, ASME B16.33/B16.38, 125 PSIG, -40°F–149°F
- CSA Class 3371-92, ASME B16.44, 5 PSIG, -40°F–149°F



#### ACCESSORIES/OPTIONS

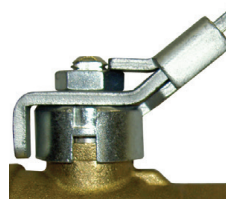

Locking Handle Kits



Tee Handle Kits



Stem Extension Kits



Memory Stops



Oval Handle Kits



Stainless Steel Handle

SPECIFICATIONS

**FIGURE 415LL**  
BRASS BODY BALL VALVES



2-PC FULL PORT\* 600 WOG LEVER LOCK BALL VALVE

CV & WEIGHTS

Size (in.)	Cv	Wt (lbs)
1/2	19	0.40
3/4	34	0.70
1	45	0.97
1-1/4	75	1.63
1-1/2	180	2.17
2	210	3.83

FIGURE NUMBER MATRIX

FNW 415LL	
SIZE CODE (IN.)	
1/2 = D	1-1/4 = H
3/4 = F	1-1/2 = J
1 = G	2 = K

REFERENCE CHART

Item #	Size (in.)	Dimensions (in.)							
		ØP	I	L	ØH	CH	R	h	Wt
FNW415LLD	1/2	0.55	0.54	2.22	1.18	0.98	3.78	1.77	0.40
FNW415LLF	3/4	0.75	0.55	2.46	1.42	1.22	4.76	2.22	0.70
FNW415LLG	1	0.94	0.66	3.01	1.71	1.50	4.76	2.32	1.00
FNW415LLH	1-1/4	1.19	0.68	3.37	2.09	1.89	5.94	2.85	1.66
FNW415LLJ	1-1/2	1.50	0.68	3.70	2.56	2.13	5.94	3.09	2.20
FNW415LLK	2	1.95	0.70	4.33	3.39	2.64	6.30	3.70	3.82

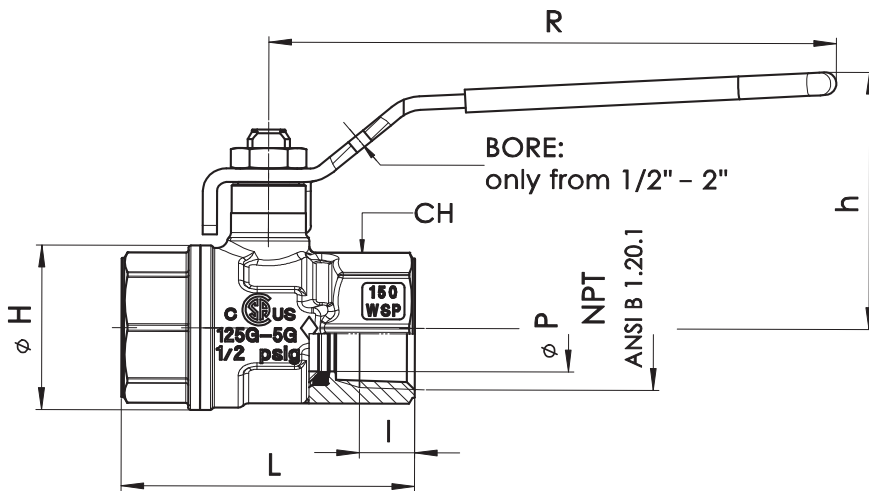

PARTS BREAKDOWN

**FIGURE 415LL**  
BRASS BODY BALL VALVES



2-PC FULL PORT\* 600 WOG LEVER LOCK BALL VALVE

PARTS DIAGRAM

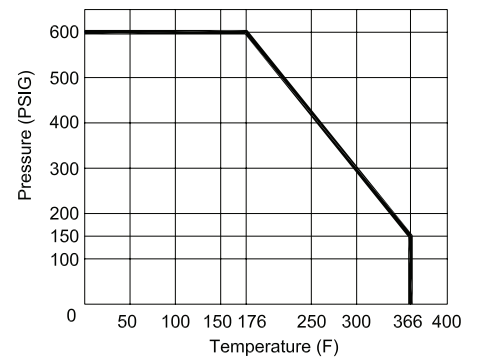
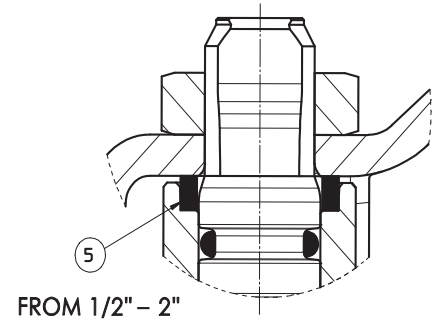
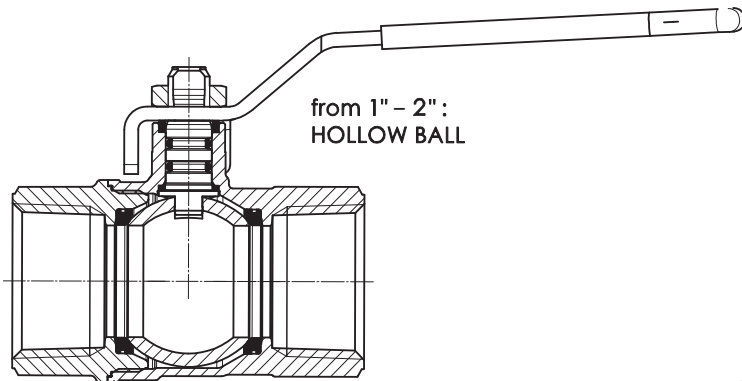
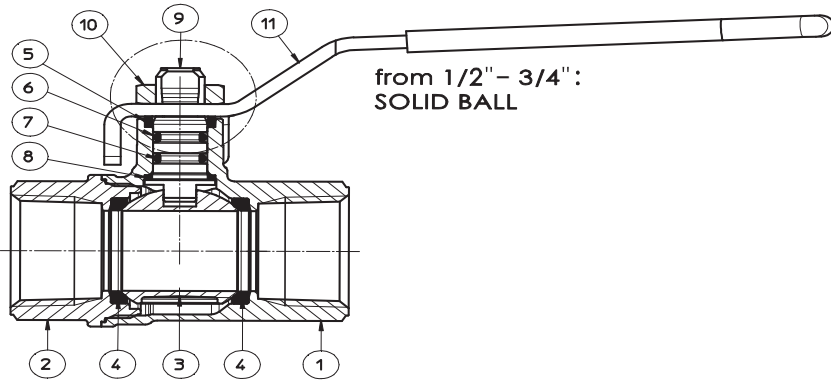

KIT CODES

FNW 420	
KIT TYPE	SIZE (IN.)
Locking Handle = LHK	1/4-1/2 = BD
Stem Extension = SE	3/4-1 = FG
Tee Handle = THK	1-1/4-1-1/2 = HJ
Oval Handle = OHK	2 = K
Memory Stop = MSK	*2-1/2-4 = LM
Stainless Handle = SSHK	

Note: Figure 415LL uses the same accessories as Figure 420.

PART MATERIALS & QUANTITY

Ref #	Description	Material	Qty
1	Body	Brass CW 617N	1
2	End Conn	Brass CW 617N	1
3	Ball	Brass CW 617N	1
4	Seat	PTFE	2
5	Packing Ring	PTFE	1
6	O-Ring	FKM	1
7	Thrust Washer	PTFE	1
8	O-Ring	NBR	1
9	Stem	Brass CW 614N	1
10	Nut	Steel CL 04	1
11	Handle	Steel DD11	1