

Installation Update

This bulletin clarifies the installation protocol recommended by DiversiTech for condensate safety overflow switches CS-1, CS-2 and CS1200.

Description

Some **Communicating HVAC Systems** using a dedicated condensate overflow safety switch shutdown input will require the use of an additional (optional) relay. The additional relay is only required if, after the installation of the above products, the HVAC system does not properly shutdown during verification testing.

Testing

Proper system shutdown verification testing is performed by first, ensuring that the system is running normally. Then,

- For CS-1 & CS-2, raising the Pull-To-Test lever
- For CS1200, pushing the test button

And finally, check that the system shuts down as expected. If the unit does not shutdown, your unit is more sensitive to switch characteristics than traditional systems and, therefore, requires a relay. Please proceed to implement the relay solution outlined below.

Action

Use a normally open SPST relay with a 24VAC coil (DiversiTech part # D90-290Q or equivalent) to break the condensate overflow safety shutdown input circuit. DiversiTech condensate switch CS-1, CS-2, or CS1200 should be used to make or break control power to the relay coil.

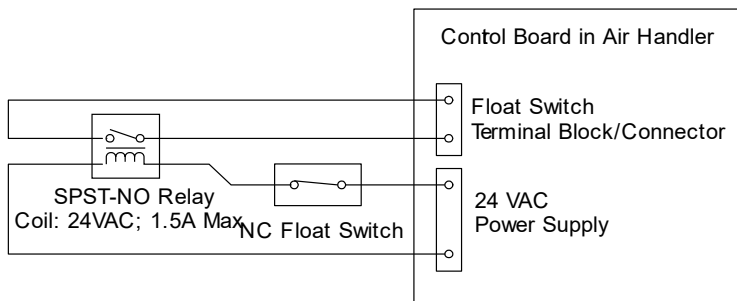

Please contact DiversiTech Customer Service at (800) 995-2222 with any questions.

CHECK BACK FOR ADDITIONAL INFORMATION

