

3025 SELFLEVEL Assembly

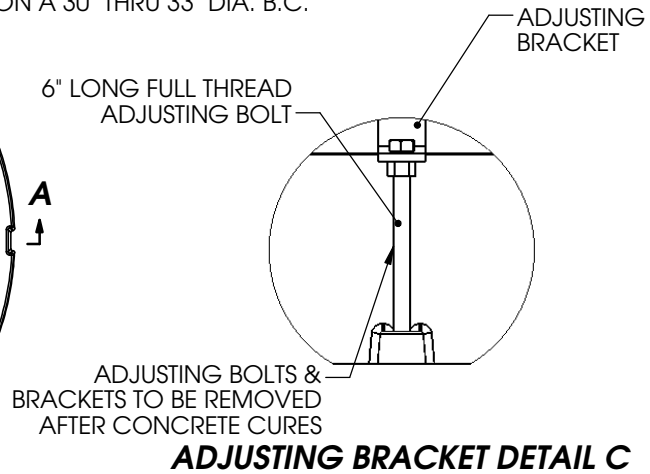

SPECIAL GASKET FOR KEEPING OUT DEBRIS & STILL ALLOWING FULL RANGE OF MOTION **SECTION B-B**

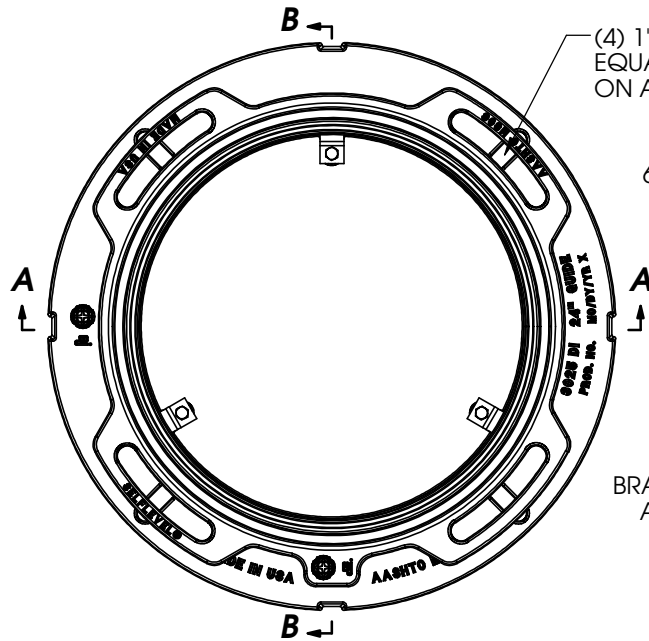
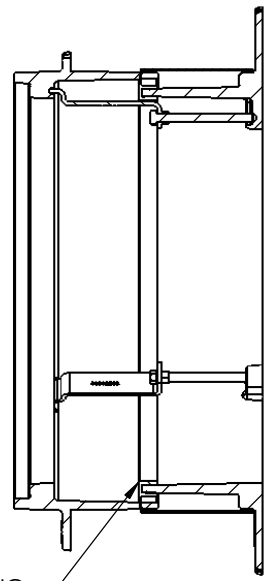

Product Number
00302515A01

Design Features

- Materials
- Frame Ductile Iron (70-50-05)
- Frame Ductile Iron (70-50-05)

- Design Load Heavy Duty
- Open Area n/a
- Coating Undipped
- √ Designates Machined Surface

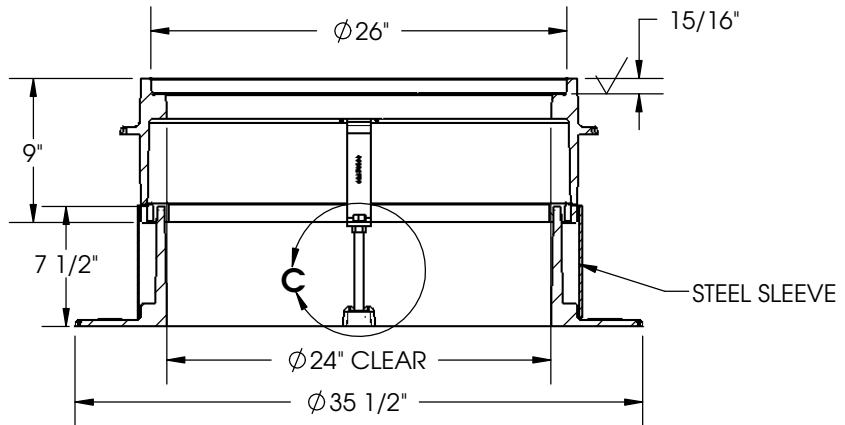

SECTION A-A

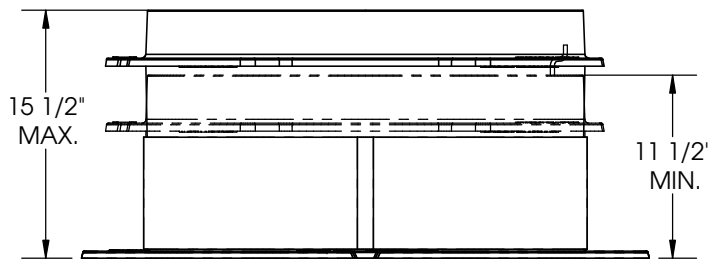

SIDE VIEW (SHOWING TRAVEL OF UPPER FRAME)

Certification

- ASTM A536
- AASHTO M306
- Country of Origin: USA

Major Components

00302515
00302519

Drawing Revision

2/28/2009 Designer: JIJ
10/08/2014 Revised By: DJH



FRONT VIEW (SHOWING MAXIMUM TIP @ 5° ANGLE)

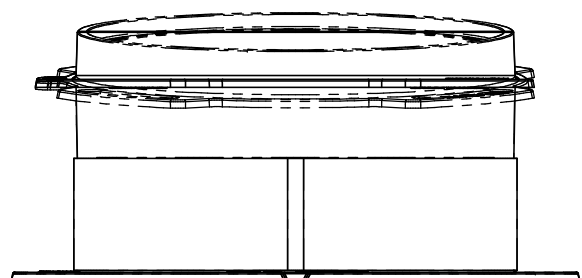

SIDE VIEW (SHOWING MAXIMUM TIP @ 5° ANGLE)

Disclaimer

Weights (lbs/kg), dimensions (inches/mm) and drawings provided for your guidance. We reserve the right to modify specifications without prior notice.

CONFIDENTIAL: This drawing is the property of EJ Group, Inc. and embodies confidential information, registered marks, patents, trade secret information, and/or know-how that is the property of EJ Group, Inc. Copyright © 2011 EJ Group, Inc. All rights reserved.

Contact

800.626.4653
ejco.com