



MODEL OS-100

Outdoor Sensor Kit

for Model 3200-Plus and
Model 3250-Plus
Fuel Smart HydroStats

Kit Includes

- Outdoor Reset Sensor with 9-foot cable
- Sensor mounting bracket with 2 screws and 1 wire clip
- Two spade connectors
- Knockout wire bushing

WARNING **Electrical shock hazard.** To prevent electrical shock, death or equipment damage, disconnect power supply before installing or servicing control. Only qualified personnel may install or service this control in accordance with local codes and ordinances. Read instructions completely before proceeding.

CAUTION To prevent serious burns, boiler should be thoroughly cooled before installing or servicing control.

This document provides instructions for connecting the Hydrolevel Outdoor Sensor Kit to an installed Fuel Smart HydroStat control. For information on installing the HydroStat control, please refer to the installation instructions provided with the control or log onto www.hydrolevel.com.

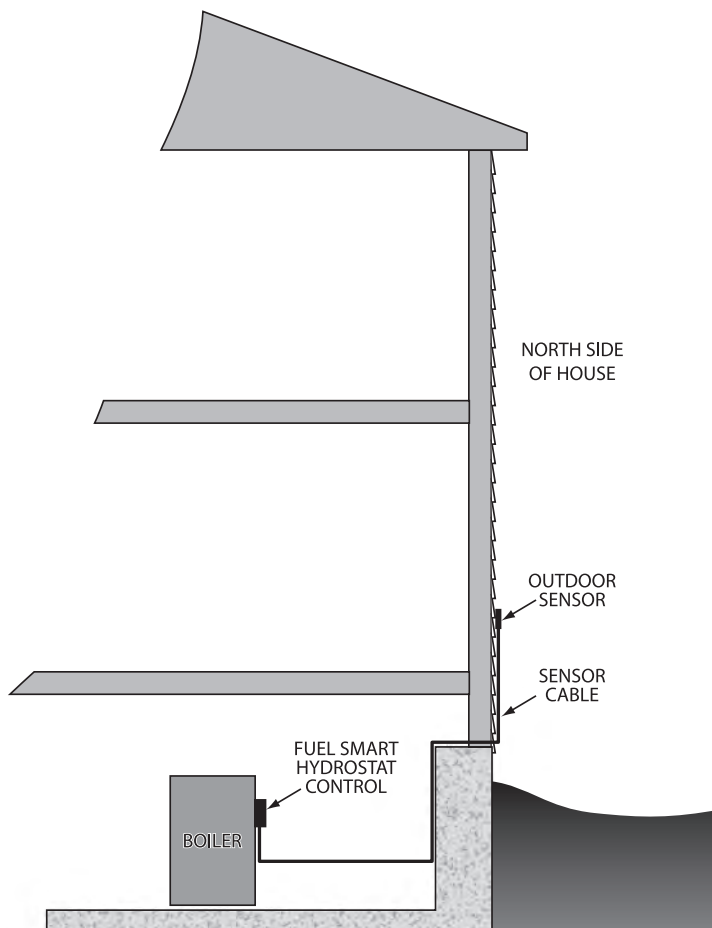

Before installation, determine the proper location for the sensor

- Sensor should be mounted on the northern outside wall of the house, shielded from direct sunlight.
- Sensor should be installed high enough off the ground to protect it from accidental damage or drifting snow.
- Sensor should be installed away from potential heat sources such as exhaust fans, windows, or doors.

INSTALLING THE SENSOR

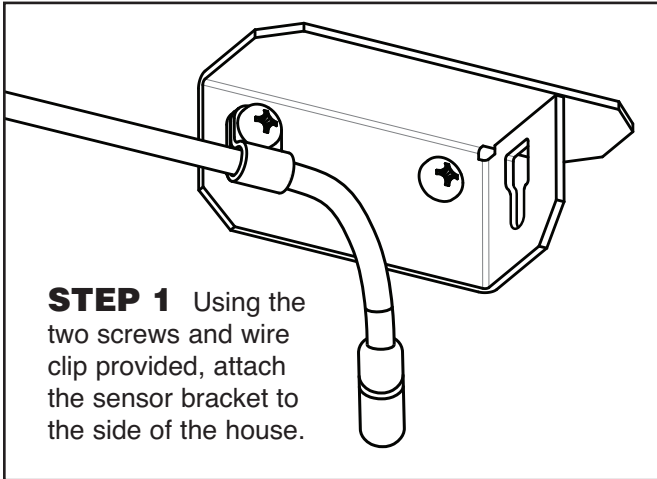

STEP 1 Using the two screws and wire clip provided, attach the sensor bracket to the side of the house.

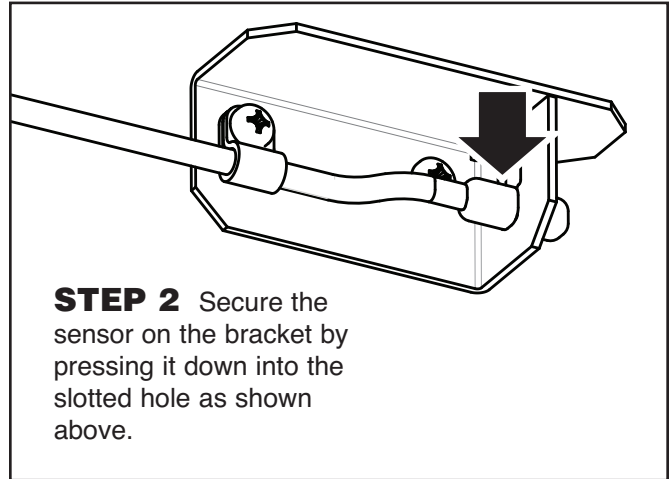

STEP 2 Secure the sensor on the bracket by pressing it down into the slotted hole as shown above.

STEP 3 Using an extended wood or masonry bit, drill a 1/4" hole through the side of the house at a location giving the best access to the boiler and the HydroStat control.

WARNING: Use caution to select the hole location away from wires or piping within the house wall.

STEP 4 Feed the sensor cable through the hole and into the house. Seal the hole with a bead of silicone or other appropriate caulking material.

STEP 5 Inside the house, route the sensor cable to the HydroStat control. Splice in an additional length of wire as needed and, using a crimping tool or pliers, terminate with the two spade connectors provided.

NOTE: To avoid interference with the sensor signal, do not run the sensor cable close to any other wiring such as telephone, cable, power, etc.

WIRING

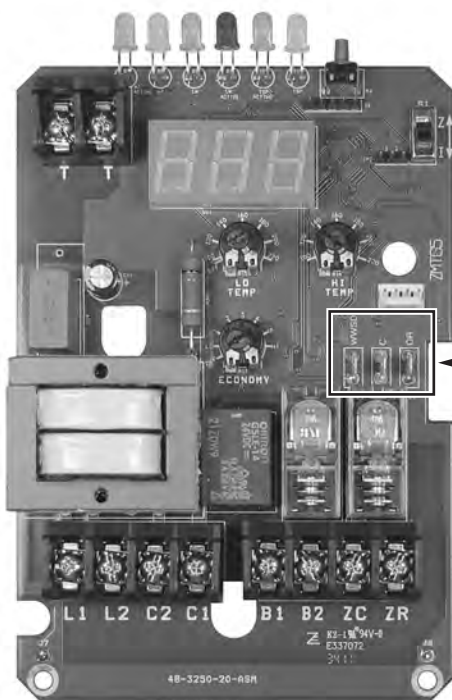

Locate the three quick connect posts on the HydroStat circuit board. The sensor cable will plug into two of these terminals depending on the features to be used.

OUTDOOR RESET AND WARM WEATHER SHUTDOWN

Attach the spade connectors to the **right** and **center** spade posts (**OR** and **C**) for full outdoor reset functionality including warm weather shutdown protection. Wiring this way overrides the Thermal Targeting function of the Fuel Smart HydroStat control.

WARM WEATHER SHUTDOWN ONLY

Connect the wire ends to the **left** and **center** spade connectors (**WWS** and **C**) to add warm weather shutdown functionality only. When wired this way, the Fuel Smart HydroStat control will utilize its internal Thermal Targeting function to reset the boiler temperature.

SETTING THE CONTROL

IMPORTANT: The outdoor sensor must be plugged in prior to setting the control.

SETTING WARM WEATHER SHUTDOWN

The warm weather shutdown feature prevents the boiler from providing space heating when the outside temperature reaches a level that you select. Available settings range from OFF or 40°- 70°F. The boiler will still operate to satisfy a call for domestic hot water. The factory default setting for the warm weather shutdown is 70°F.

To set the desired warm weather shutdown temperature:

Press and hold the TEST/SETTING BUTTON and simultaneously adjust the ECONOMY dial to the desired setting. To turn the feature off – which will allow space heating regardless of outdoor temperature – press and hold the TEST/SETTING BUTTON and simultaneously turn the ECONOMY dial fully counter-clockwise. Release the TEST/SETTING BUTTON. Be sure to reset the ECONOMY dial to the correct setting.

SETTING THE OUTDOOR RESET

The outdoor reset will regulate the boiler's temperature based on the temperature outside. On cold days, the boiler will run at higher temperatures to meet the heating load in the house. On warmer days, the boiler will run cooler to save energy while still meeting the heating needs of the house. The HydroStat control uses a Reset Ratio to calculate and maintain the proper boiler temperature.

To set the desired outdoor Reset Ratio:

- Determine the Reset Ratio using the table below:
 - Locate the Outdoor Design Temperature for the system on the bottom of the Reset Ratio Chart below. Round down to the next lowest number.
 - Locate the Boiler Design Temperature (supply temperature needed to meet heating load at the Outdoor Design Temperature) on the left of the Reset Ratio Chart below.
- Adjust the ECONOMY dial on the Fuel Smart HydroStat control to the Reset Ratio determined by the intersection of a. and b. above.

Example: For a house located in Springfield MA (Design Temperature of 0°F) with baseboard heat (that was sized for the house based on the 180°F baseboard rating), the reset ratio is 1.50.

RESET RATIO CHART

BOILER TEMPERATURE	220	1.50	1.50	1.50	1.50	1.75	1.75	1.75	2.00	2.00	2.25	2.50	2.50	2.50	2.50	2.50	2.50	2.50	
	215	1.25	1.50	1.50	1.50	1.50	1.75	1.75	1.75	2.00	2.25	2.25	2.50	2.50	2.50	2.50	2.50	2.50	
	210	1.25	1.25	1.50	1.50	1.50	1.50	1.50	1.75	2.00	2.00	2.25	2.50	2.50	2.50	2.50	2.50	2.50	
	205	1.25	1.25	1.25	1.50	1.50	1.50	1.50	1.75	1.75	2.00	2.25	2.25	2.50	2.50	2.50	2.50	2.50	
	200	1.25	1.25	1.25	1.50	1.50	1.50	1.50	1.75	1.75	2.00	2.00	2.25	2.50	2.50	2.50	2.50	2.50	
	195	1.00	1.25	1.25	1.25	1.50	1.50	1.50	1.50	1.75	1.75	2.00	2.25	2.25	2.50	2.50	2.50	2.50	
	190	1.00	1.00	1.25	1.25	1.25	1.50	1.50	1.50	1.75	1.75	2.00	2.00	2.25	2.50	2.50	2.50	2.50	
	185	1.00	1.00	1.00	1.25	1.25	1.25	1.25	1.50	1.50	1.75	1.75	2.00	2.25	2.50	2.50	2.50	2.50	
	180	1.00	1.00	1.00	1.00	1.25	1.25	1.25	1.50	1.50	1.50	1.75	2.00	2.00	2.25	2.50	2.50	2.50	
	175	1.00	1.00	1.00	1.00	1.25	1.25	1.25	1.50	1.50	1.50	1.75	1.75	2.00	2.25	2.50	2.50	2.50	
	170	1.00	1.00	1.00	1.00	1.00	1.25	1.25	1.25	1.50	1.50	1.50	1.75	1.75	2.00	2.25	2.50	2.50	
	165	0.75	1.00	1.00	1.00	1.00	1.00	1.00	1.25	1.25	1.50	1.50	1.50	1.75	2.00	2.25	2.50	2.50	
	160	0.75	0.75	0.75	1.00	1.00	1.00	1.00	1.25	1.25	1.25	1.50	1.50	1.75	1.75	2.00	2.25	2.50	
	155	0.75	0.75	0.75	0.75	1.00	1.00	1.00	1.00	1.25	1.25	1.25	1.50	1.50	1.75	2.00	2.25	2.50	
	150	0.75	0.75	0.75	0.75	0.75	1.00	1.00	1.00	1.00	1.25	1.25	1.50	1.50	1.75	1.75	2.00	2.50	
	145	0.75	0.75	0.75	0.75	0.75	0.75	0.75	1.00	1.00	1.00	1.25	1.25	1.50	1.50	1.75	2.00	2.25	
	140	0.75	0.75	0.75	0.75	0.75	0.75	0.75	0.75	1.00	1.00	1.00	1.25	1.25	1.50	1.50	1.75	2.00	
		-40	-35	-30	-25	-20	-15	-10	-5	0	5	10	15	20	25	30	35	40	45
		OUTDOOR DESIGN TEMPERATURE																	

Refer to the Fuel Smart HydroStat instructions for other control settings.

HOW THE OUTDOOR SENSOR WORKS

OUTDOOR TEMPERATURE RESET

The outdoor reset feature monitors outdoor temperature to continuously adjust the boiler water to the minimum temperature required to satisfy the heat demand. The feature is activated automatically when the sensor is wired to the OR and C spade connects on the Fuel Smart HydroStat. When connected, Outdoor Reset overrides the Thermal Targeting temperature reset method which is built into the Fuel Smart HydroStat. The display will toggle between boiler temperature (8 seconds) and outdoor temperature (2 seconds). If the sensor becomes damaged or disconnected, the control will automatically revert back to the Thermal Targeting reset method. The display will no longer toggle outdoor temperature.

RESET RATIO

The Fuel Smart HydroStat control's Outdoor Reset feature uses a reset ratio method to control the boiler temperature. The reset ratio determines how much the boiler temperature is adjusted for changes in outdoor temperature. A reset ratio of 2.0 means that for each 1 degree increase in outdoor temperature, the boiler temperature will decrease 2 degrees. Conversely, for each 1 degree drop in outdoor temperature, the boiler temperature will increase 2 degrees. The control adds 10 degrees to the calculated reset temperature and provides a 20 degree differential for burner operation. So, if the control calculates a reset temperature of 150°F, it will set a target temperature of 160°F. It will then allow the burner to fire up to 160°F and draw down to 140°F before re-firing. This operation will maintain the desired average temperature of 150°F. You can check the current target temperature at any time, by pressing the Test/Settings button in 4 short intervals.

THERMAL BOOST

To insure that the heating system always satisfies a call for heat, the Fuel Smart HydroStat control is equipped with a thermal boost feature. If the thermostat is not satisfied thirty minutes after the boiler reaches the reset temperature, the control will boost the reset temperature by 10 degrees. It will continue to boost at 30 minute intervals until the call is satisfied. Once the call is satisfied, the control reverts to normal operation, utilizing the calculated reset temperature.



LIMITED MANUFACTURER'S WARRANTY

We warrant products manufactured by Hydrolevel Company to be free from defects in material and workmanship for a period of two years from the date of manufacture or one year from the date of installation, whichever occurs first. In the event of any claim under this warranty or otherwise with respect to our products which is made within such period, we will, at our option, repair or replace such products or refund the purchase price paid to us by you for such products. In no event shall Hydrolevel Company

be liable for any other loss or damage, whether direct, indirect, incidental or consequential. This warranty is your EXCLUSIVE remedy and shall be IN PLACE OF any other warranty or guarantee, express or implied, including, without limitation, any warranty of MERCHANTABILITY or fitness for a particular purpose. This warranty may not be assigned or transferred and any unauthorized transfer or assignment thereof shall be void and of no force or effect.