

Compressor DEFENDER™

Surge/Brownout/Short Cycle Protective Device

The Compressor Defender protects compressors (scroll & reciprocating) and the electronics inside Central Air conditioners and heat pumps from under/over voltage conditions, scroll reversal caused by brief power disruptions, surge events and system short cycling.

Features

- Surge, brownout and short cycle protection with 120, 208 and 240 VAC loads
- Short cycle delay helps extend compressor life
- LED indicators provide real-time status updates for quick and easy troubleshooting
- For use inside condensing units or externally on disconnects
- Complies with ANSI/AHRI Standard 110-2016 Range B for voltage drop protection
- Auto-sense voltage technology 120/208-240 VAC universal input voltage
- Meets ANSI/UL 1449, 4th Edition requirements

Ratings

Input Voltage:	120/208-240 VAC Single Phase, 60 Hz
Thermostat Relay:	Normally Closed Relay, 24 VAC
SPD Type:	Type 2 SPD
Control Output Current Rating:	2 A @ 24 VAC, isolated NC contact
Max Continuous Overvoltage (MCOV):	L-N/G: 150 V, L-L: 300 V
Voltage Protection Rating (VPR):	L-N/G: 700 V, L-L:1200 V
Nominal Discharge Rating (In):	10 kA
SCCR (Short Circuit Current Rating):	20 kA
Undervoltage Response Time:	5 line cycles*
Power Disruption Response Time:	3 line cycles*
Short Cycle Delay:	3 min
Operating Temp:	-40° F to 158° F (-40° C to 70° C)
Enclosure:	Type 3 Outdoor
Wire Size:	#10 AWG
Shipping Weight:	1.2 lbs
Product Warranty:	3-year limited
Connected Equipment Warranty:	3-year/ \$7500

Brownout Pickup Table:

Nominal System Voltage	Range B Protection
120 VAC	104 VAC
208 VAC	180 VAC
240 VAC	208 VAC

*Typical Response Time

Project: _____

Location: _____

Product Type: _____

Contact/Phone: _____

Model #: _____

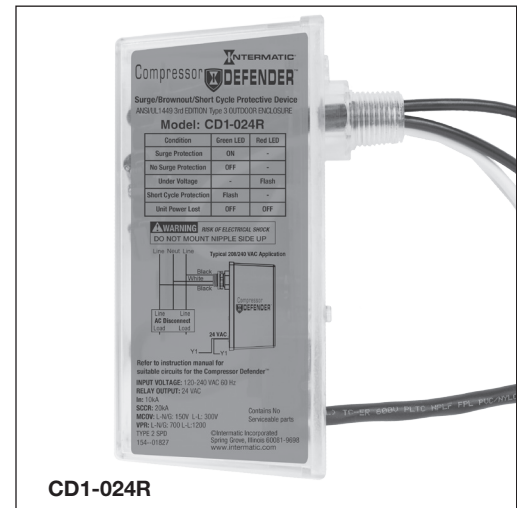

Model Number	Voltage	Enclosure	Short Cycle Delay
--------------	---------	-----------	-------------------

CD1-024R	120/208/240 VAC	Type 3 Outdoor	3 Minutes
----------	-----------------	----------------	-----------

Specification

Furnish and install an Intermatic CD1-024R Compressor Defender™. The unit shall protect HVAC Compressors (Scroll & Reciprocating) and the electronics inside central air conditioners, heat pumps, light commercial packaged rooftop units from under/overvoltage conditions, power disruptions, surge events and system short cycling caused from AC power interruptions. The unit shall be capable of opening up to a 2 A @ 24 VAC thermostat connection. The unit shall be compatible with 120, 208 and 240 VAC voltage systems. The unit shall provide Type 2 surge protection with a nominal discharge rating of 10 kA, a short circuit current rating of 20 kA and a voltage protection rating of L-N/G:700 V, L-L:1200 V. The unit shall have a 3-minute short cycle delay. The Compressor Defender™ shall have normally closed operation. If surge or voltage monitoring protection is lost, the unit shall continue normal compressor and thermostat operation without surge protection.

Diagrams

Typical 120 VAC Application

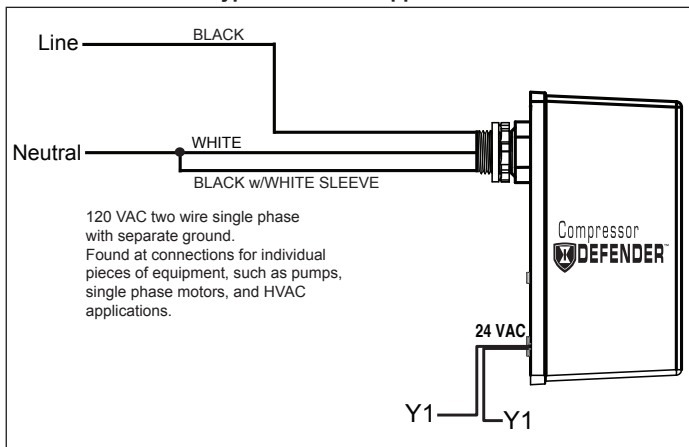

Typical 208-240 VAC Application

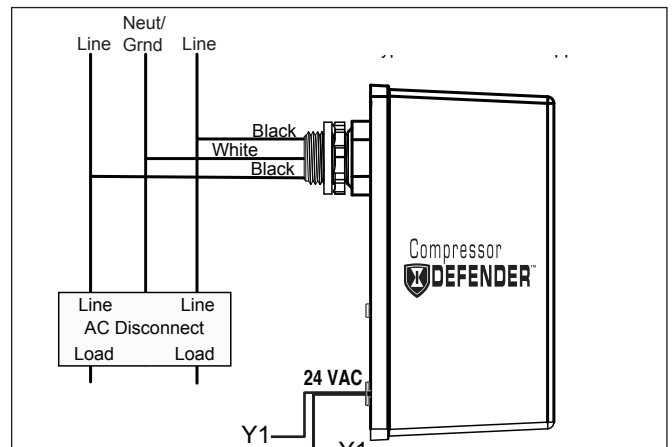

Mounting Inside Panel/Condenser

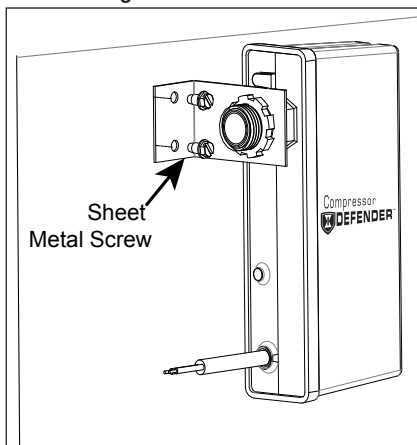

Diagnostic Indicator Key

Condition	Green LED	Red LED
Surge Protection	ON	-
No Surge Protection	OFF	-
Under Voltage	-	Flash
Short Cycle Protection	Flash	-
Unit Power Lost	OFF	OFF