

TECHNICAL SPECIFICATIONS

KDS 3060

MODEL NUMBER 142036

DIMENSIONS: 59 3/4" x 30" x 80 1/8" Gelcoat

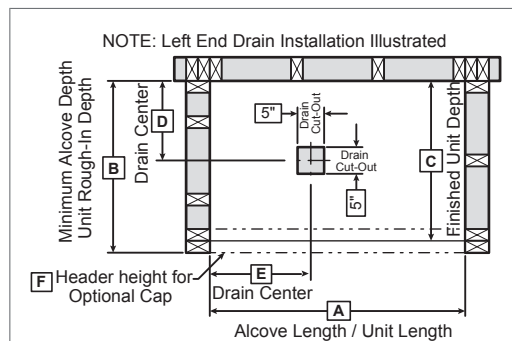

Model	No Seat					Seat
	A	B	C	D	E	D
142036	60"	31"	30"	30"	14 1/8"	8 5/8"

STANDARD FEATURES

- Four-piece gelcoated fiberglass shower with PIN system for easy front installation
- Large top corner shelves, wide soap dish and standard acrylic handle (opt. metallic finishes)
- Right/left-hand seat (drain opposite to seat) or no seat (center drain)
- Optional unique features:
Reinforced walls and grab bars
- Product also available in Above-the-Floor Rough
- Textured floor

UNIQUE FEATURES

- PIN system

OPTIONS

- Shower base only KDS 3060 with pin system
- Side walls (right and left) for KDS 2954, KDS 3060 and KDS 3060
- Back wall for KDS 3060, KDS 3260, KDS 3060 and KDS 3460
- Wall reinforcement (one wall)
- 18" Modern straight grab bar
- 24" Modern straight grab bar

SYSTEMS

- None

DOOR SELECTION

Combine with AKER's complete **CERTIFICATIONS** visit www.akerbymax.com for one or more of the following certifications:



Project :

Contractor :

AKER Representative : Tel :

Date :

TECHNICAL SPECIFICATIONS

KDS 3060

MODEL NUMBER 142036

TECHNICAL DRAWINGS

STANDARD

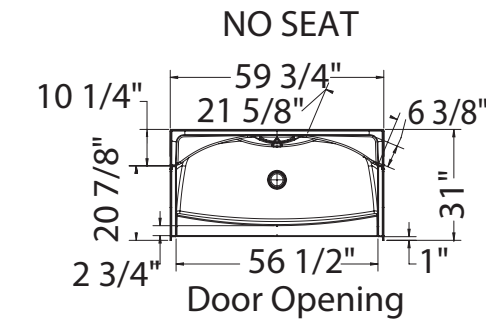

RIGHT SEAT SHOWN LEFT SEAT SYMMETRICAL

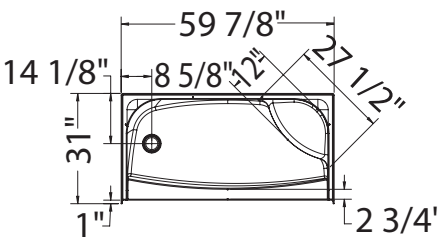

NOT ABOVE-THE-FLOOR

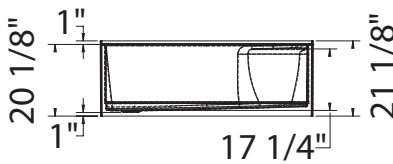

ABOVE-THE-FLOOR

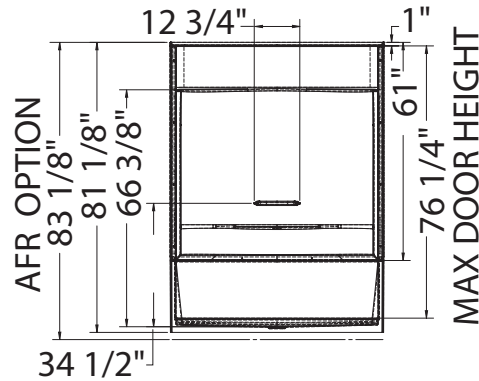
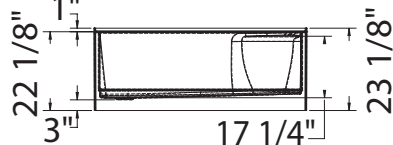

REINFORCEMENT BACKING OPTION 20212-L Shown OPTION 20212-R Symetrical

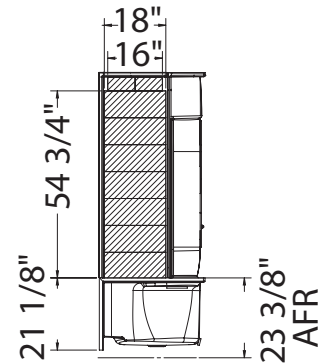

OPTION 20212-B

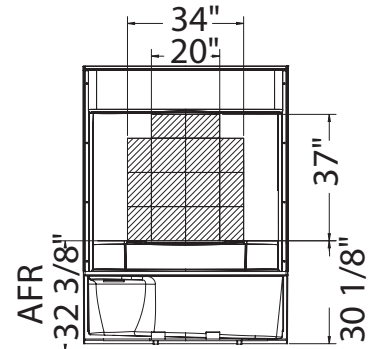

GRAB BARS

OPTION 20203

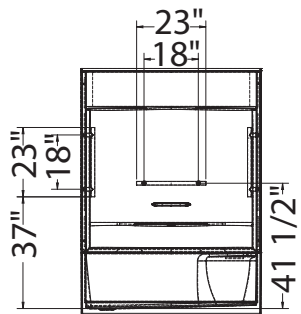

OPTION 20204

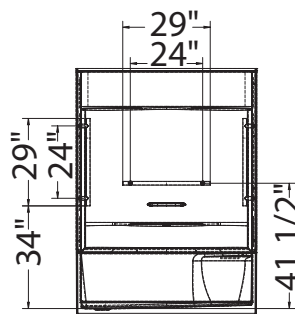

OPTION 20203-20204

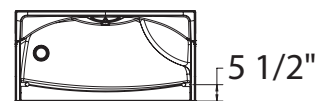

All dimensions are approximate. Structure measurements must be verified against the unit to ensure proper fit.