



CENTRO II WASHING MACHINE OUTLET BOX TECHNICAL SPECIFICATION

Job Name _____	Item # _____
Location _____	
Engineer _____	Contractor _____
PO # _____	Tag _____
Representative _____	

SPECIFICATIONS

Oatey's Centro II Washing Machine Box is used for commercial and residential washing machine applications. Oatey's Centro WMOB can be mounted with the valves on the top or bottom. Oatey's WMOB comes with two support brackets and two piece valves.

DESCRIPTION

- Takes up less space and will fit almost anywhere.
- WMOB made of PVC.
- Brackets and Faceplate made of HIPS.
- 2 knockout drain caps.
- 2" Socket Hubs.
- Mountable with valves on top or bottom.
- 2 piece valves come uninstalled or installed.
- Two support brackets.
- Available in a wide variety of tailpiece configurations and packaging options.

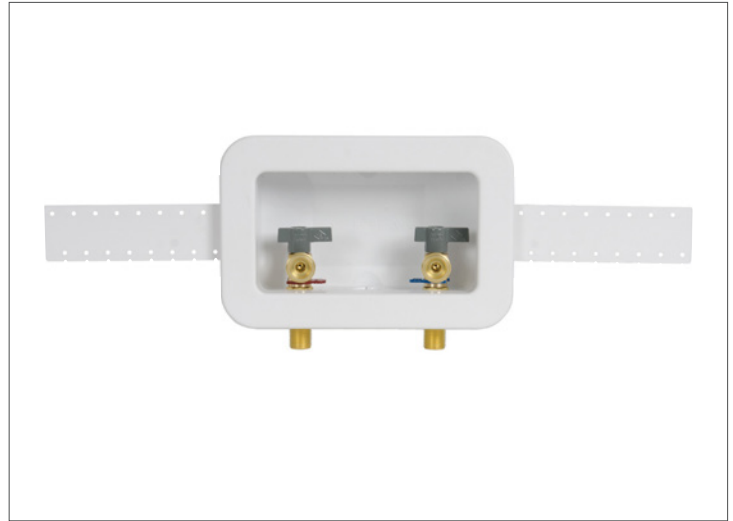

APPROVALS AND LISTINGS

Valves	ASME A112.18.1 / CSA B125.1 NSF / ANSI 61 & 372
Water Hammer Arrestors	ASSE 1010
Boxes	IAPMO-Listed, PS-54



DIMENSIONS

[A]:	Box Width	10.30"	[F]:	Bracket Height	1.97"
[B]:	Box Height	6.38"	[G]:	Bracket Width	7.25"
[C]:	Box Opening Width	7.84"	[H]:	Faceplate Width	10.19"
[D]:	Box Opening Height	4.46"	[I]:	Faceplate Height	6.71"
[E]:	Box Depth	3.03"	[J]:	Faceplate Depth	0.75"

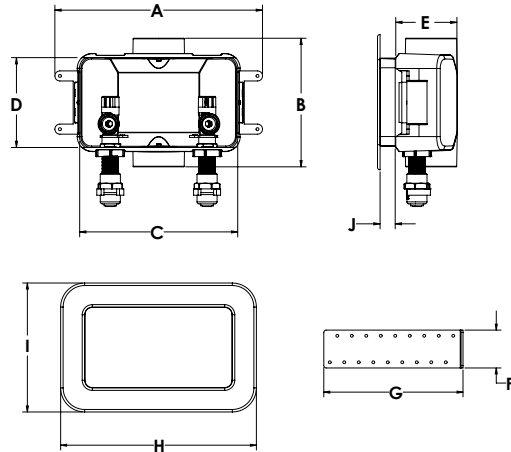

PRODUCT SELECTOR

NO HAMMER ASSEMBLED			
✓	Product Number	Description	CTN. QTY.
	38100	¼ Turn, Copper, No Hammer, Assembled, Standard Pack	12
	38102	¼ Turn, CPVC, No Hammer, Assembled, Standard Pack	12
	38104	¼ Turn, ASTM F1807, No Hammer, Assembled, Standard Pack	12
	38106	¼ Turn, ASTM F1960, No Hammer, Assembled, Standard Pack	12
	38150	¼ Turn, Copper, No Hammer, Assembled, Contractor Pack	12
	38153	¼ Turn, CPVC, No Hammer, Assembled, Contractor Pack	12

Access BIM/Revit content through www.oatey.com