

Industrial and Utility Hand Tools and Manual Machine Components

PLC15



LOWELL
CORPORATION

Making tough jobs easier since 1869

It all boils down to you and a problem. And all that stands between success and failure is the solution you choose. And the tools you choose.

Tough tools for the toughest jobs.

Maybe you're a lineman trying to repair a transmission tower on a windy night.

Or you're a utility operator trying to attach a band clamp on a leaking gas pipe during a rainstorm.

Or you're a product designer trying to engineer a machine that has to set new standards of productivity.

At Lowell, we know how tough these jobs can be. And we know how important it is to find the right solution. So we've got you covered with an array of ratchet tools and devices that make it easier to solve the toughest problems. Efficiently, economically, safely.

We've been making tough jobs easier since 1869.

Contents

High Line Utility Applications

- 8 Dual End Series Socket Wrenches
 - 8D Quad Square Socket Wrench
- 9 Triple Square Fabricated Handle Wrenches
 - Triple Square Cast Handle Wrenches
- 10 Pad Mount Transformer Wrenches
 - Triple Square Tower Wrenches
 - Lineman's Transmission Wrenches
- 11 Triple Square Impact Socket
 - Triple Square Transmission Impact Socket

Water Utility and Construction Applications

- 12 50/150 Series Wrenches
 - Series QR Quick Release Wrenches
 - 50T SureTork® Torque Wrench
- 13 DoubleShot Dedicated Socket Wrenches
 - 8C 4-in-1 Wrench
 - 8D DoubleShot Plus Wrench
 - 8E Articulating Wrench
- 14 Socket Wrench Ordering Information
- 16 Socket Wrench Sets
- 18 50F Heavy Duty Hydrant Wrenches
 - Pipe Wrench Head Adapter
 - Model 252F Hydrant Wrench
- 19 Valve Wheel Wrenches
 - Valve Key Socket Set
 - Strap Wrenches
- 20 T-Torker® Torque Wrenches
 - Impakdriver
- 21 Crank Handles
- 22 Crank Handles Ordering Information

- 23 Ratchet Arms: 10/10Z/40 Series
- 24 Ratchet Arms:
 - 100 Series
 - Model 101 SS
 - Model 104/105
- 25 Ratchet Arms:
 - 20 Series
 - 200 Series Double Handle
- 26 Ratchet Arms Ordering Information
- 28 Roller Clutches
- 26 Ratchet Clutches
- 30 Ratchet Clutches
 - 70 Series
 - 700 Series
- 32 Ratchet Clutches Ordering Information
- 33 Observation Windows
- 34 Custom Ratchets
 - Repair Parts
- Back Cover Warranty

Making tough jobs easier 40 feet in the air.

Tools for the high line

Lowell tools make tough jobs easier for high line utility workers. With innovative features like bolt-thru design, our rugged square and hex ratchet socket wrenches can easily handle all kinds of fasteners found in electrical transmission and distribution applications.



Socket Wrenches
Page 8



Torque Wrenches
Page 20



Socket Wrench Sets
Page 16



Impact Sockets
Page 11



Transformer Wrenches
Page 10



Tower Wrenches
Page 10



Making tough jobs easier in the field.

Tools for water utility and construction

Lowell tools make tough jobs easier for utility and construction workers. With our innovative features such as bolt-thru design and multi-angle adjustable handles, our rugged ratchet socket wrenches can easily engage all kinds of nuts found in water, oil and gas pipeline work and in hydrant maintenance and operation.

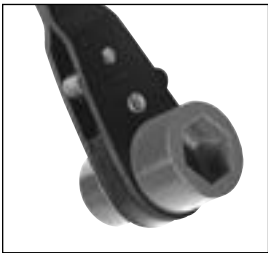

Double Shot Wrenches
Page 13



Socket Wrench Sets
Pages 16

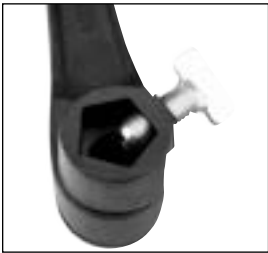

Hydrant Wrenches
Page 18



Strap Wrenches
Page 19



Valve Wheel Wrenches
Page 19



Torque Wrenches
Page 20



Making tough jobs easier in the design process.

OEM Machine Components

Lowell machine components and devices make tough jobs easier for design engineers. All our ratchet arms and clutches provide reliable, economical machinery control without external power sources. Perfect for many functions such as positioning, opening/closing, speed regulation, and feeding.

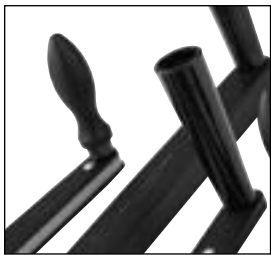

Crank Handles
Page 21



Roller Clutches
Page 28

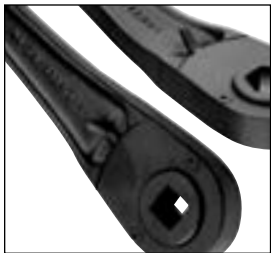

Ratchet Arms
Page 23

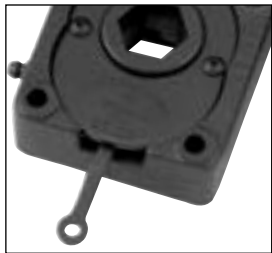

Ratchet Clutches
Page 26



Observation Windows
Page 33



Custom Ratchets
Page 34





Dual End Series
Model 100TDE



Dual End Series
Model 101TDE



Dual End Series
Model 103TDE



Model 8D
Quad Square

Designed to meet the specific needs of high line utility linemen

- Fluorescent orange, cast iron sockets make the wrenches harder to lose, easier to track
- Sockets fit most common utility pole fasteners: lag bolts, C-clamps and suspension bolts
- Bolt-thru design lets long bolts pass entirely through wrench head
- Durable and able to withstand the demands of rugged duty
- Compact and light weight
- Easy to carry: fits most common holsters

Dual End Series Triple Square Lineman's Socket Wrench

- Three Models: 100 TDE 101TDE 103TDE
- Three square sizes in one permanent socket 3/4" x 1" x 1-1/8"
- Two hex sizes in the other permanent socket 9/16" x 3/4"
- 3/4" hex socket will also turn 5/8" square nuts



Bolt-thru design

- Fits in common holsters
- Fabricated steel handle
- Ideal for working in tight spots: socket end requires only an 11° swing; gear end requires only a 12° swing
- Bolt-thru design lets long bolts pass entirely through wrench head

8D Quad Square Wrench

- Four square sizes in one permanent socket 3/4" x 13/16" x 1" x 1-1/8"
- Powerful: 200 lb-ft torque capability
- Compact: only 13" long
- Bolt-thru design lets long bolts pass entirely through wrench head
- Full length ergonomic handle grip lets a worker grab the tool at any point
- Ideal for working in tight spots: 36 ratchet teeth yield a 10° handle throw
- High-Vis sockets and grip

Series 150T Triple-Square Fabricated Handle Wrenches

- Three square sizes in one permanent socket
3/4" x 1" x 1-1/8"
- Fabricated steel handles
- Large reversing lever on side of head
- Bolt-thru design lets long bolts pass entirely through wrench head
- Ergonomic handle grips
- Semi-enclosed ratchet mechanism (Models 150T and 151T only)
- Fit in most common holsters



Series 150T
Model 101T



Series 150T
Model 151T

Series 50T Triple Square Cast Handle Wrench

- Enclosed ratchet mechanism
- Fits in common holsters
- Reversing lever at head
- Three square sizes all in one permanent socket:
3/4" x 1" x 1-1/8"
- Cast iron handle
- Bolt-thru design lets long bolts pass entirely through wrench head

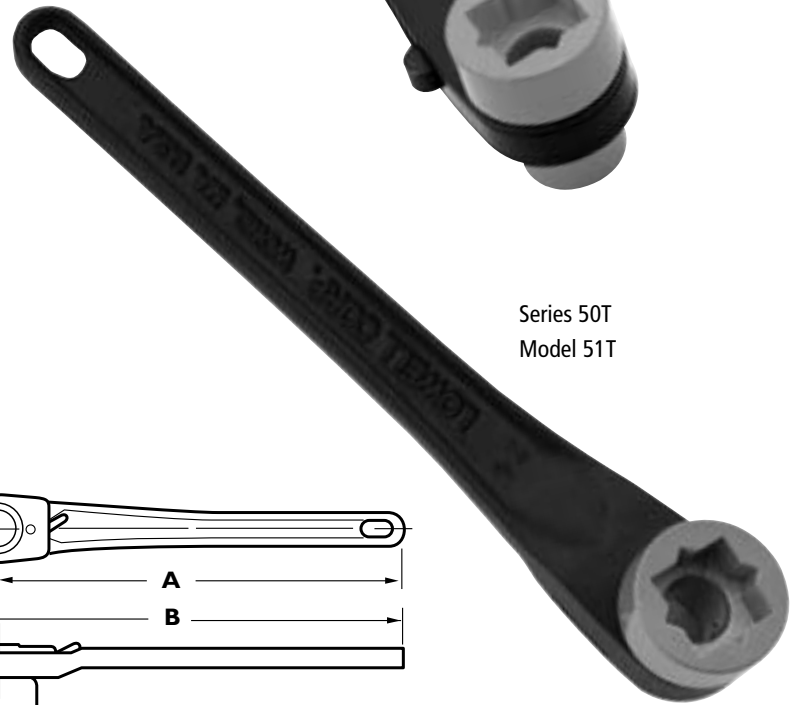

Series 50T
Model 51T

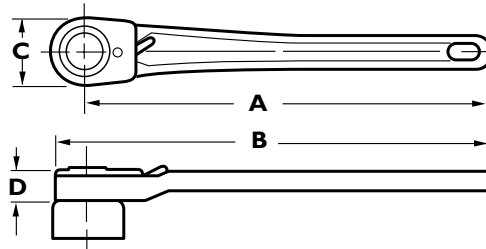
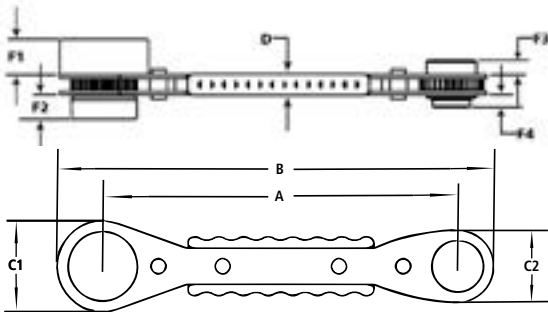

S = Square H = Hex

Model	A	B	C or C1	C2	D	F1	F2	Opening	Weight	Part number
50DS	10"	11"	2-1/16"	-	15/16"	7/8"	-	1" x 1-1/8" S	2 lbs	50901-94818
50T	10"	11"	2-1/16"	-	15/16"	7/8"	1"	13/16" x 1" x 1-1/8" S	2 lbs	50901-94800
51DS	12"	13"	2-1/16"	-	15/16"	7/8"	-	1" x 1-1/8" S	2-1/8 lbs	51901-94818
51T	12"	13"	2-1/16"	-	15/16"	7/8"	1"	13/16" x 1" x 1-1/8" S	2-1/8 lbs	51901-94800
101T	8-1/4"	9-1/4"	2-1/16"	-	13/16"	3/4"	7/8"	13/16" x 1" x 1-1/8" S	1-1/2 lbs	23-07509-9900
100TDE	8-1/4"	9"	1-7/8"	1-1/2"	1/2"	3/4"	1/2"	13/16" x 1" x 1-1/8" S socket w/ 9/16" x 3/4" H gear	1-1/4 lbs	8B4T3
101TDE	8-1/4"	9-1/4"	2-1/16"	1/12"	13/16"	7/8"	1"	13/16" x 1" x 1-1/8" S socket w/ 9/16" x 3/4" H gear	2 lbs	23-30109-9900
103TDE	11-1/4"	12-1/14"	2-1/16"	1-1/2"	13/16"	7/8"	1"	13/16" x 1" x 1-1/8" S socket w/ 9/16" x 3/4" H gear	2-1/4 lbs	23-30209-9900
150DS	10"	11"	2-1/16"	-	13/16"	7/8"	-	1" x 1-1/8" S	2 lbs	87901-94818
150T	10"	11"	2-1/16"	-	13/16"	7/8"	1"	13/16" x 1" x 1-1/8" S	2 lbs	87901-94800
151DS	12"	13"	2-1/16"	-	13/16"	7/8"	-	1" x 1-1/8" S	2-1/4 lbs	88901-94818
151T	12"	13"	2-1/16"	-	13/16"	7/8"	1"	13/16" x 1" x 1-1/8" S	2-1/4 lbs	88901-94800
8D QS	12-1/4"	13-1/4"	2-1/16"	-	1/2"	3/4"	1/2"	3/4" x 13/16" x 1" x 1-1/8" S	1-3/8 lbs	8D4T1



Model 101XRS-1
Pad Mount
Transformer Wrench



Model 103T
Triple Square Tower Wrench

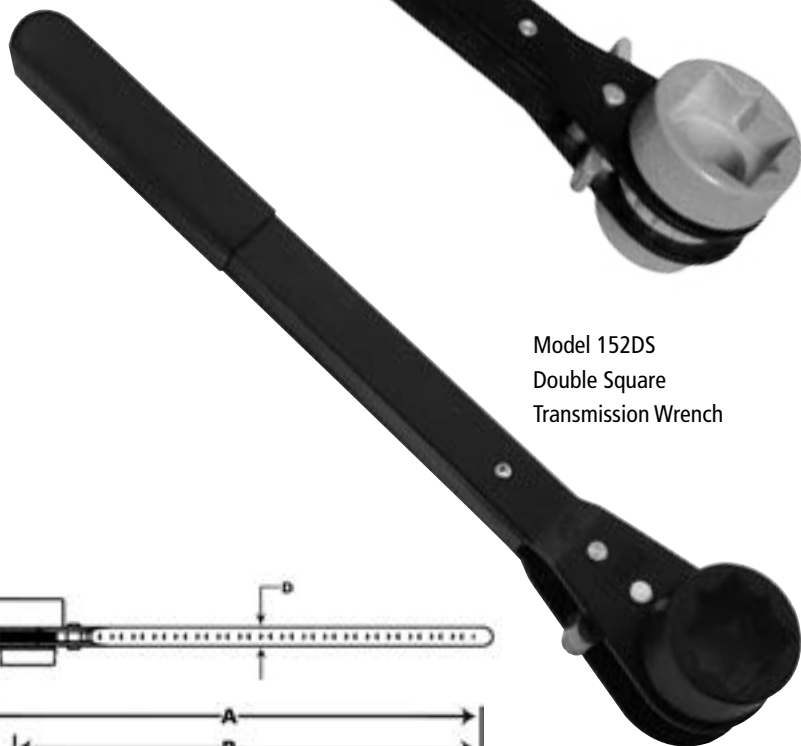

Model 152DS
Double Square
Transmission Wrench

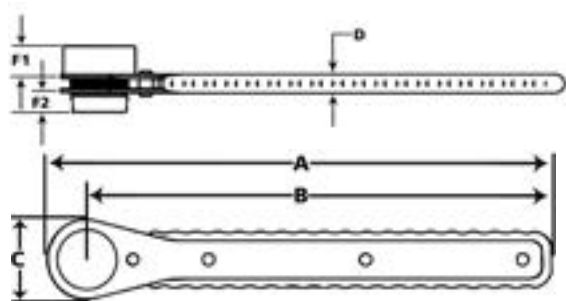

Model	A	B	C	D	F1	F2	Opening	Weight	Part number
103T	12"	13-1/4"	2-1/2"	7/8"	1"	3/4"	1-1/8" x 1-5/16" x 1-1/2" Sq.	2-3/4 lbs	103L1-L3824
104T	15"	16-1/4"	2-1/2"	7/8"	1"	3/4"	1-1/8" x 1-5/16" x 1-1/2" Sq.	3 lbs	104L1-L3824
105T	18"	19-1/4"	2-1/2"	7/8"	1"	3/4"	1-1/8" x 1-5/16" x 1-1/2" Sq.	3-3/8 lbs	105L1-L3824
52 DS	15"	16-1/8"	2-7/16"	1-7/16"	1-1/4"	-	1-5/16" x 1-7/16" Sq.	4-1/8 lbs	52901-95823
53 DS	20"	21-1/8"	2-7/16"	1-7/16"	1-1/4"	-	1-5/16" x 1-7/16" Sq.	5 lbs	53901-95823
152 DS	15-3/4"	17"	2-1/2"	1-7/16"	1-1/4"	-	1-5/16" x 1-7/16" Sq.	3-3/4 lbs	15201-95823

Pad Mount Transformer Wrenches

Designed for 5-point (security pentagon) and 3/4" hardware used in pad mount transformers.

- Three models: 101XRS-1 3/4" Hex x security pentagon; 101XRS-2 security pentagon x 5/16" Allen; 101XRS-3 3/4" Hex x 5/16" Allen
- Large reversing lever on side of head
- Sturdy ratchet mechanism reverses with the flick of a lever
- 32 teeth reduce throw angle for work in tight spots
- Wrench head pinned to reduce wobbling for better torque and less wear
- Torque tested to 90 lb-ft
- Vinyl grip for comfort
- Weight 1-1/2 lbs
- Length 8"
- p/n 101XRS-1 21-824X1-0000 101XRS-2 21-824X2-0000 101XRS-3 21-824X3-0000

Triple-Square Tower Wrenches

Provides greater flexibility when dealing with the most common tower fastener nut sizes.

- Three models: 103T, 104T, 105T
- Three square nut sizes 1-1/8" x 1-5/16" x 1-1/2"
- Large reversing lever on side of head
- Sturdy ratchet mechanism reverses with the flick of a lever
- Bolt-thru design lets long bolts pass entirely through wrench head
- Vinyl grip for comfort
- Coated with epoxy paint for durability and easy cleaning
- Socket painted fluorescent orange for high visibility
- Up to 300 lb-ft torque

Double Square Transmission Wrench

- Two cast iron models and one fabricated steel model
- Two square sizes in one permanent socket 1-5/16" x 1-7/16"
- Combination socket also turns 1-1/2" hex nuts
- Variety of other square and hex sockets available
- Reversing lever at head
- Bolt-thru design
- Enclosed ratchet mechanism (Models 52DS, 53DS only)

Triple Square Impact Socket

Use with any impact wrench to install or maintain utility pole hardware.

- Three square sizes in one socket
13/16" for 1/2" hardware
1" for 5/8" hardware
1-1/8" for 3/4" hardware
- 7/16" hex quick change adapter is included
- Length, 7-3/4" weight, 2 lbs
- Assembly Number: 23-26908-9900

Triple Square Transmission Impact Socket

Use with any impact wrench or rattle gun to install or maintain transmission tower hardware.

- Three square openings in one socket:
1-1/8" for 3/4" hardware
15/16" for 7/8" hardware
1-1/2" for 1" hardware
- 7/16" hex quick-change adapter included
- 11/16" diameter, 6" long hollow shaft allows use on long threaded bolts
- Slim profile and light weight ensure easy handling
- Narrowed center allows easy grip, with or without gloves
- Length 10-3/8", weight 3-1/2 lbs
- 100% made in USA
- Assembly Number: T8T29



Impact Socket
with Adapter

Impact Socket

Transmission
Impact Socket
with Adapter

Impact Socket
Adapter

Transmission
Impact Socket
Adapter

Transmission
Impact Socket

50/150 Series Wrenches

Durable for heavy-duty applications such as pipeline and construction

- Takes a wide range of square and hex sockets
- Retaining ring is easily removed for socket replacement or changeover
- Reversing control in head
- Enclosed ratchet mechanism on Series 50; semi-enclosed mechanism on Series 150
- Series 150 offers a lower cost alternative without sacrificing any performance
- Models 150, 151 have ergonomic nonslip grip
- Bolt-thru design for tightening nuts on long bolts



Series 50

Series 150



Quick-Release makes socket changing fast and easy. Available on Models 50QR, 51QR, 52QR, 53QR and 564QR.

Series QR Reversible Wrenches with Quick Release

- Unique Bolt-Thru design
- Model 564 QR has multi-angle handle adjustable in 30° increments
- Quick-Release for fast socket changes
Models 50QR, 51QR, 52QR, 53QR and 564QR



Series QR
Model 564QR

50ST SureTorq® Pipeline Torque Wrench

Ensures properly torqued nuts on clamps.

- Field-adjustable torque from 30–150 lb-ft in one lb-ft increments
- Handle clicks when torque setting is reached
- Quick release socket for fast socket changes.
- Reversing control in bolt-thru head



SureTorq Torque Wrench

For specs and ordering info, go to page 14.

DoubleShot Series

Heavy-duty dedicated wrenches designed specifically for pipeline, maintenance, utility and construction workers.

- Ten socket size combinations for heavy, standard and metric hex nuts, as well as hydrant repair
- Sockets made of rugged cast iron
- Fluorescent orange sockets make the wrenches harder to lose
- Handle and sockets coated with durable electrostatic epoxy paint for easy cleaning
- Reversing control in head
- Stamped, riveted handle
- Ergonomic non-slip grip
- Bolt-thru design lets long bolts pass entirely through wrench head
- All wrenches 12" long weight 2-1/4 lbs



Double Shot

8C 4-in-1 Wrench

Can handle four most common nut sizes found in utility and construction work

- 1-1/4" x 1-1/16" hex and 1-1/8" x 15/16" hex.
- Rugged 17" stamped steel handle has an ergonomic grip for greater comfort
- 36 tooth ratchets yield a 10° swing—ideal for working in tight spots
- Easy-to-reverse ratchet mechanism has few parts for greater reliability
- 200 lb-ft torque for turning power without breaking
- HiVis handle makes wrench easy to find
- Solid metal sockets grip nuts firmly
- Weight 2-1/2 lbs Made in USA
- Bolt-thru design



8c 4-in-1

Model 8D DoubleShot Plus

For pipeline installation and repair, combines two wrenches in one.

- Available with two 2-in-1 socket sizes
- 12-point socket openings
- Two hex socket combos: 1-1/4" x 1-1/16"; 1-1/8 x 15/16"
- 36 ratchet teeth for short 10° handle throw
- 200 lb-ft torque capacity
- Hi-Vis sockets and ergonomic handle grip
- Length handle, 12-1/4" overall 13-1/4"
- Weight 1-3/8 lbs

Model 8D



Model 8E DoubleShot Articulating Wrench

For pipeline installation and repair, combines two wrenches in one for work in tight quarters.

- Reversible articulating head
- Available with two 2-in-1 socket sizes
- 12-point socket openings
- Two hex socket combos: 1-1/4" x 1-1/16"; 1-1/8 x 15/16"
- 36 ratchet teeth for short 10° handle throw
- 200 lb-ft torque capacity
- Hi-Vis sockets and ergonomic handle grip
- Length handle, 17" overall, 21-1/2"
- Weight 2-3/8 lbs
- Also available as 4E4K1 kit with one handle, two heads

Model 8E



Specs and ordering info on next page

Socket Wrenches

50 Series/150 Series

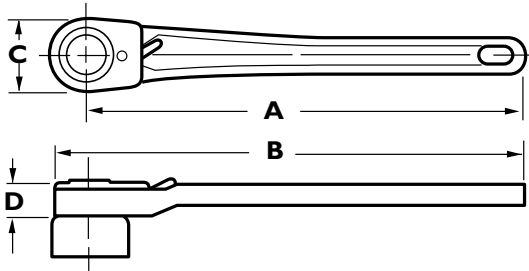

Model	P/N Handle Only	A	B	C	D	Weight
50	50901	10"	11"	2-1/16"	15/16"	2 lbs
50QR	509Q1	10"	11"	2-1/16"	15/16"	2 lbs
50ST	25810	21-1/4"	22-1/4"	2-1/16"	15/16"	4-1/4 lbs
51	51901	12"	13"	2-1/16"	15/16"	2-1/8 lbs
51QR	519Q1	12"	13"	2-1/16"	15/16"	2-1/8 lbs
564QR	36925	15-1/2"	16-1/2"	2-1/16"	15/16"	3-1/4 lbs
150	87901	10"	11"	2-1/16"	13/16"	2 lbs
151	88901	12"	13"	2-1/16"	13/16"	2-1/8 lbs
158	86901	8"	9"	2-1/16"	13/16"	1-3/4 lbs
52	52901	15"	16-1/8"	2-7/16"	1-7/16"	4-1/8 lbs
52QR	529Q1	15"	16-1/8"	2-7/16"	1-7/16"	4-1/8 lbs
53	53901	20"	21-1/8"	2-7/16"	1-7/16"	5 lbs
53QR	539Q1	20"	21-1/8"	2-7/16"	1-7/16"	5 lbs
152	15201	15-3/4"	17"	2-1/2"	1-3/16"	3-3/4 lbs
54	54901	24"	25-5/8"	3-3/16"	1-11/16"	9-1/4 lbs
56	56901	36"	38-1/8"	4-13/16"	1-7/8"	24 lbs
58	58901	43-1/2"	46-5/8"	6-1/4"	1-15/16"	47 lbs
60	60901	60"	64-5/8"	9-1/4"	2-1/2"	100 lbs

DoubleShots 8D DoubleShot PLUS

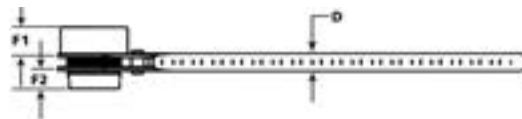
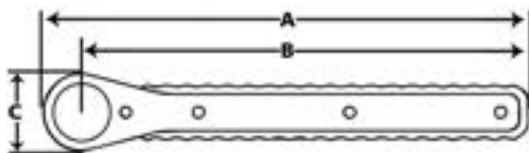

DoubleShot Dual Socket Wrenches

Model	A	B	C	D	F1	F2	Weight	Openings	P/N Assembly
DS-1	12"	13"	2-1/16"	13/16"	1-1/16"	15/16"	2-1/4 lbs	1-1/4" x 1-1/16" H	88901-DBSH/94820-5909
DS-2	12"	13"	2-1/16"	13/16"	1-1/16"	15/16"	2-1/4 lbs	1-1/8" x 15/16" H	88901-DBSH/94818-5909
DS-3	12"	13"	2-1/16"	13/16"	7/8"	1"	2-1/4 lbs	15/16" H x 3/4" H	88901-DBSH/94815-5909
DS-4	12"	13"	2-1/16"	13/16"	7/8"	15/16"	2-1/4 lbs	7/8" x 3/4" H	88901-0005/94814-5903
DS-5	12"	13"	2-1/16"	13/16"	7/8"	15/16"	2-1/4 lbs	22 mm x 19 mm H	88901-0005/94822-5903
DS-6	12"	13"	2-1/16"	13/16"	1-1/16"	15/16"	2-1/4 lbs	1-1/8" H x 1-1/16" H	88901-DBSH/94817-5909
DS-7	12"	13"	2-1/16"	13/16"	7/8"	15/16"	2-1/4 lbs	19 mm x 17 mm H	88901-0005/M4819-5909
DS-8	12"	13"	2-1/16"	13/16"	1-1/16"	15/16"	2-1/4 lbs	24 mm X 22 mm H	88901-DBSH/M4824-5909
DS-9	12"	13"	2-1/16"	13/16"	1-1/16"	15/16"	2-1/4 lbs	30 mm x 24 mm H	88901-DBSH/M4830-5909
DS-10	12"	13"	2-1/16"	13/16"	1-1/16"	15/16"	2-1/4 lbs	1-1/4" x 1-18" H	88901-DBSH/94821-5909

8D DoubleShot PLUS Dual Socket Wrenches

Model	A	B	C	D	F1	F2	Weight	Openings	P/N Assembly
DSP-1	12-1/4"	13-1/4"	2-1/16"	1/2"	3/4"	1/2"	1-3/8 lbs	1-1/4" x 1-1/16" H	8D4D1
DSP-2	12-1/4"	13-1/4"	2-1/16"	1/2"	3/4"	1/2"	1-3/8 lbs	1-1/8" x 15/16" H	8D4D2

8E

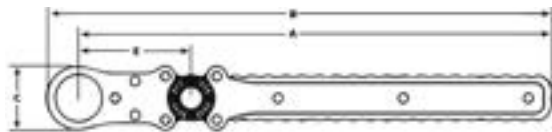

8E Articulating Dual Socket Wrenches

Model	A	B	C	D	E	F1	F2	Weight	Openings	P/N Assembly
8E4D1	16"	17"	2-1/16"	1/2"	3-3/4"	3/4"	1/2"	2-3/8 lbs	1-1/4" x 1-1/16" Hex	8E4D1
8E4D2	16"	17"	2-1/16"	1/2"	3-3/4"	3/4"	1/2"	2-3/8 lbs	1-1/8" x 15/16" Hex	8E4D1

8C

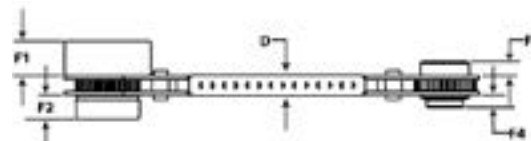
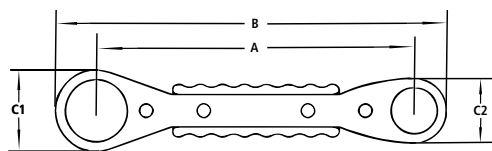

8C 4-IN-1 Ratcheting Box Wrench

Model	A	B	C1 & C2	D	F1 & F3	F2 & F4	Weight	Openings	P/N Assembly
8C4Q1	15"	17"	2-1/16"	1/2"	3/4"	1/2"	2-1/2 lbs	1-1/4" x 1-1/16" x 1-1/8" x 15/16" Hex	8C4Q1

Model	P/N Handle Only	Socket	P/N Socket Only	Model	P/N Handle Only	Socket	P/N Socket Only	Model	P/N Handle Only	Socket	P/N Socket Only
50	50901	5/8" S	94610	52		32 mm H	M5732	56	56901	1-13/16" S	97629
50QR	509Q1	11/16" S	94611	52QR		33 mm H	M5733			2" S	97632
50ST	25810	3/4" S	94612	53		36 mm H	M5736			2-3/16" S	97635
51	51901	1" S	94616	53QR		38 mm H	M5738			2-1/4" S	97636
51QR	519Q1	1-1/16" S	94617	152		41 mm H	M5741			2-3/8" S	97638
564QR	36925	1-1/8" S	94618			50 mm H	M5750			2-1/2" S	97640
150	87901	1-1/4" S	94620	54	54901	1" S	96616			3" S	97648
151	88901	16 mm S	M4616			1-1/16" S	96617			50 mm S	M7650
158	86901	17 mm S	M4617			1-1/8" S	96618			60 mm S	M7660
		19 mm S	M4619			1-1/4" S	96620			65 mm S	M7665
		22 mm S	M4722			1-5/16" S	96621			1-5/8" H	97726
		24 mm S	M4624			1-3/8" S	96622			1-13/16" H	97729
		25 mm S	M4625			1-7/16" S	96823			1-7/8" H	97730
		27 mm S	M4627			1-1/2" S	96624			2" H	97732
		28 mm S	M4628			1-5/8" S	96626			2-1/8" H	97734
		30 mm S	M4630			1-11/16" S	96627			2-3/16" H	97735
		32 mm S	M4732			1-13/16" S	96629			2-1/4" H	97736
		5/8" H	94710			1-7/8" S	96630			2-3/8" H	97738
		3/4" H	94712			2" S	96632			2-7/16" H	97739
		7/8" H	94714			25 mm S	M6625			2-1/2" H	97740
		15/16" H	94715			28 mm S	M6628			2-9/16" H	97741
		1" H	94716			30 mm S	M6630			2-5/8" H	97742
		1-1/16" H	94717			32 mm S	M6632			2-3/4" H	97744
		1-1/8" H	94718			34 mm S	M6634			3" H	97748
		1-1/4" H	94720			38 mm S	M6638			3-1/8" H	97750
		16 mm H	M4716			46 mm S	M6646			41 mm H	M7741
		17 mm H	M4717			47 mm S	M6647			46 mm H	M7746
		19 mm H	M4719			50 mm S	M6650			50 mm H	M7750
		22 mm H	M4722			55 mm S	M6655			55 mm H	M7755
		24 mm H	M4724			1" H	96716			60 mm H	M7760
		25 mm H	M4725			1-1/16" H	96717			65 mm H	M7765
		27 mm H	M4727			1-1/8" H	96718			70 mm H	M7770
		28 mm H	M4728			1-1/4" H	96720			80 mm H	M7780
		30 mm H	M4730			1-5/16" H	96721	58	58901	3-1/2" S	98656
		32 mm H	M4732			1-3/8" H	96722			4-1/2" S	98668
		3/4" Hxt	09904-7			1-7/16" H	96723			3" H	98748
		7/8" Hxt	09904-1			1-1/2" H	96724			3-1/8" H	98750
		15/16" Hxt	09904-2			1-5/8" H	96726			3-3/8" H	98754
		1-1/16" Hxt	09904-3			1-11/16" H	96727			3-3/4" H	98760
		1-1/8" Hxt	09904-4			1-13/16" H	96729			3-7/8" H	98762
		1-1/4" Hxt	09904-5			1-7/8" H	96730			4-1/8" H	98766
52	52901	5/8" S	95610			2" H	96732			4-1/2" H	98772
52QR	529Q1	1-1/8" S	95618			2-1/16" H	96733			4-5/8" H	98774
53	53901	1-1/4" S	95620			2-1/8" H	96734			95 mm H	M8795
53QR	539Q1	1-5/16" S	95621			2-3/16" H	96735	60	60901	9-1/8" S	A9750
152	15201	1-1/2" S	95624			2-2/4" H	96736				
		24 mm S	M5624			2-3/8" H	96738				
		30 mm S	M5630			2-5/8" H	96742				
		13/16" H	95713			24 mm H	M6724				
		7/8" H	95714			25 mm H	M6725				
		15/16" H	95715			28 mm H	M6728				
		1" H	95716			32 mm H	M6732				
		1-1/16" H	95717			36 mm H	M6736				
		1-1/8" H	95718			38 mm H	M6738				
		1-3/16" H	95719			41 mm H	M6741				
		1-1/4" H	95720			42 mm H	M6742				
		1-5/16" H	95721			46 mm H	M6746				
		1-7/16" H	95723			47 mm H	M6747				
		1-1/2" H	95724			50 mm H	M6750				
		1-5/8" H	95726			55 mm H	M6755				
		22 mm H	M5722			60 mm H	M6760				
		24 mm H	M5724								
		25 mm H	M5725								
		27 mm H	M5727								
		28 mm H	M5728								
		30 mm H	M5730								

S = Square
H = Hex
Hxt = Hex Extended

511 and 512 Ratchet Wrench Sets

For gas or water pipeline applications

- Quick-Release for fast socket changeover
- Reversing levers in head
- Combines standard international sockets and special devices for US-style Buffalo and Erie type water main curb boxes, hydrants and corporation stops
- Standard 511 set includes: 51 QR ratchet handle; 7/8", 15/16", 1-1/8", 1-1/4" hex sockets, heavy-duty steel box.
- US version includes corporation socket, 7 lbs.
- Standard 512 set includes 51 QR ratchet handle, 3/4", 7/8", 15/16", 1-1/16", 1-1/8", 1-1/4" hex sockets, extension bar, Buffalo (2 -1/4" spanner) and Erie 7/8" (pentagonal) socket, corporation socket, and heavy-duty steel box
- Bolt-thru design
- Weights:
511, 7 lbs 512, 11 lbs
- Quick release makes socket changing quick and easy



Model 511

Model 512



SureTork Set Model 516

SureTork Torque Wrench



SureTork Set Model 516X



513 Ratchet Torque Wrench Set

For gas and water pipeline applications

- Bolt-thru design
- 0-160 lb-ft torque indicating wrench
- Ratchet adapter with Quick-Release for fast socket changeover
- Chrome-plated torque wrench
- Easy-to-read. Can be used as a standard 1/2" male drive torque wrench as well
- Standard set includes 560 torque wrench (0-160 lb/ft), 1/2" square male drive, 3-1/2" ratchet adapter, 3/4", 7/8", 15/16", 1-1/16", 1-1/8", 1-1/4" hex sockets, heavy-duty steel box
- Weight 13 lbs. Length (wrench) 18-3/4"

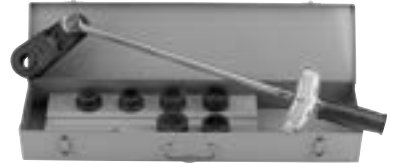

Model 513

50ST SureTork® Pipeline Torque Wrench Sets

Ensures properly torqued nuts on clamps.

- Field-adjustable torque from 30–150 lb-ft in one lb-ft increments
- Handle clicks when torque setting is reached
- Standard hex and square sockets from 5/8" to 1-1/4"
- Extended reach hex sockets from 3/4" to 1-1/4"
- Quick release socket for fast socket changes.
- Reversing control in head
- Bolt-thru design
- Length: 21-1/4"
- Weights: standard hex, 4-1/4 lbs. extended hex, 5 lbs.

SureTork Set Model 516

Includes one SureTork wrench and six hex sockets:
3/4", 7/8", 15/16", 1-1/16", 1-1/8", 1-1/4"
Weight: 12 lbs

SureTork Set Model 516X

Includes one SureTork wrench and five extended hex sockets:
7/8", 15/16", 1-1/16", 1-1/8", 1-1/4"
Weight: 10-1/2 lbs

521 and 531 Ratchet Wrench Sets

For larger applications: utility and pipeline transmission and distribution, maintenance and construction

- Large size international sockets
- Longer handles for increased leverage
- Bolt-thru design
- Quick-Release for fast socket changeover
- Reversing levers in head
- Standard 521 set includes 52 QR ratchet handle, five hex sockets (1-1/4", 1-5/16", 1-7/16", 1-1/2", 1-5/8"), heavy-duty steel box that can hold three additional sockets which may be ordered with set
- Standard 531 set includes 53 QR handle, five hex sockets (1-1/4", 1-5/16", 1-7/16", 1-1/2", 1-5/8"), heavy-duty steel box that can hold three additional sockets which may be ordered with set
- Weight 521 set, 13-1/2 lbs 531 set, 14 lbs



Model 521



Model 531



Model 514



DoubleShot Ratchet Wrench Sets

Designed for specific applications. Each set includes three DoubleShot wrenches in a molded plastic case.

- Mechanical joints, restraints, couplings, sleeves, repair clamps, saddles, flange bolts
- DS-IN Installation Set includes: DS-1 1-1/4" x 1-1/16" DS-2 1-1/8" x 15/16" DS-4 3/4" x 7/8"
- DS-RP Repair Set includes: DS-1 1-1/4" x 1-1/16" DS-2 1-1/8" x 15/16" DS-3 15/16" x 3/4"
- Also available DS-LC Economy Set
- Weight 10 lbs

511X Extended Reach Ratchet Wrench Set

Greater leverage in tight spots

- Ideal for attaching mechanical joints in close quarters
- Each socket extends 3-1/2" from the handle to allow for clearance over obstacles
- Quick-Release for fast socket changeover
- Heavy duty plastic case
- Standard set includes Model 51 quick release handle, five extended hex sockets (7/8", 15/16", 1-1/16", 1-1/8", 1-1/4")
- Bolt-thru design
- Weight 10 lbs



514 Adjustable Angle Ratchet Wrench Set

For ratchet action in close quarters

- Multi-angle handle adjustable in 30° increments
- Locks quickly via wing nut
- Quick-Release for fast socket changeover
- Shear pin design to prevent overtorquing
- Standard set includes 564 QR adjustable handle
- 3-1/2" ratchet adapter, 3/4", 7/8", 15/16", 1-1/16", 1-1/8", 1-1/4" hex sockets
- Heavy-duty steel box
- Weight 11 lbs

Series 50F Heavy Duty Hydrant Wrenches

For US-style water hydrants

- Available in 2 sizes: 52F and 53F
- Opens, closes any hydrant in only a 22 1/2° swing
- Long handle, pentagon socket for better leverage
- Sockets adjust by thumb screw for versatile set-up
- Socket has 9/16" square opening, accessible by turning wrench over

Series 50F Hydrant Wrenches

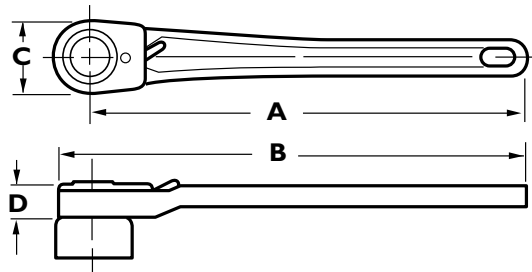

Model	A	B	C	D	Weight	Socket Openings	P/N Assembly
52F	15"	16-1/8"	2-7.16"	1-7/16"	4-1/8 lbs	1-1/2" Pentagon	52901/95824
						2" Pentagon	52901/95832
						1-3/4" Pentagon x	
						1-1/4" Square combo	52901/95828
53F	20"	21-1/8"	2-7.16"	1-7/16"	5 lbs	1-1/2" Pentagon	53901/95824
						2" Pentagon	53901/95832
						1-3/4" Pentagon x	53901/95828
						1-1/4" Square combo	

Series 50F
Model 52F

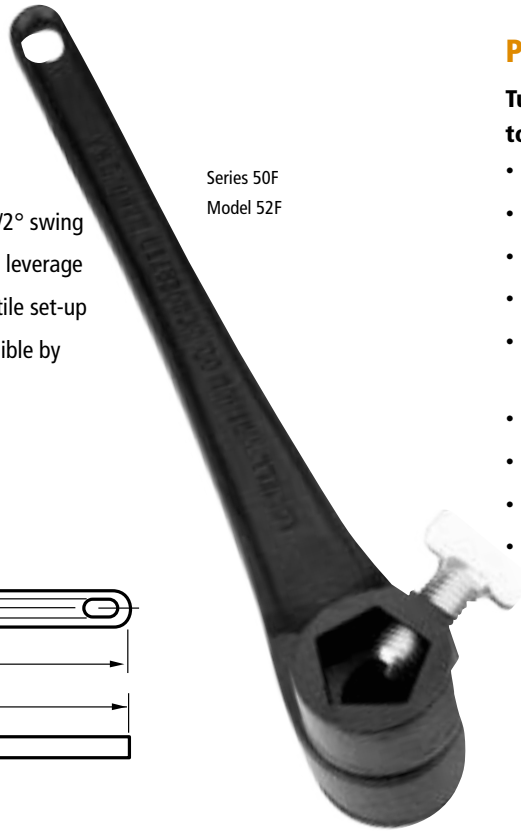

Pipe Wrench Head Adapter

Turns any breaker bar, square male drive ratchet or torque wrench into a pipe wrench.

- Fits any standard 1/2" square male drive
- Jaws open from 1-1/2" to 5-1/4"
- 285 lb-ft torque
- All steel construction for rugged duty
- When used with a ratchet, the unique stop bar prevents unwanted ratcheting during repositioning.
- Easy to grab from different angles for work in tight spots
- Lengths closed, 5" open, 7-1/2"
- Weight: 3-1/4 lbs.
- p/n 3A901



Pipe Wrench
Head Adapter

Model 252F Hydrant Wrench

- Two handles give greater leverage for loosening and tightening nuts
- Improves safety by allowing operator to always face the road
- Permits two-person operation

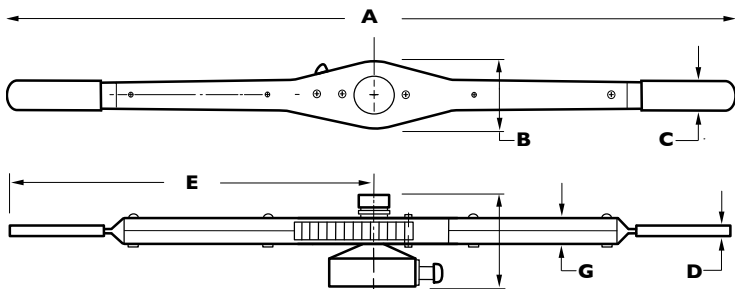

Model	A	B	C	D	E	Weight	Socket Openings	P/N Assembly
252	32-1/2"	2-5/8"	1"	5/16"	16-1/4"	6-1/4 lbs	1-1/2" Pentagon	23-13708-9900/95824
							2" Pentagon	23-13708-9900/95832
							1-3/4" Pentagon x	23-13708-9900/95828
							1-1/4" Square combination	

Model 252F
Hydrant Wrench

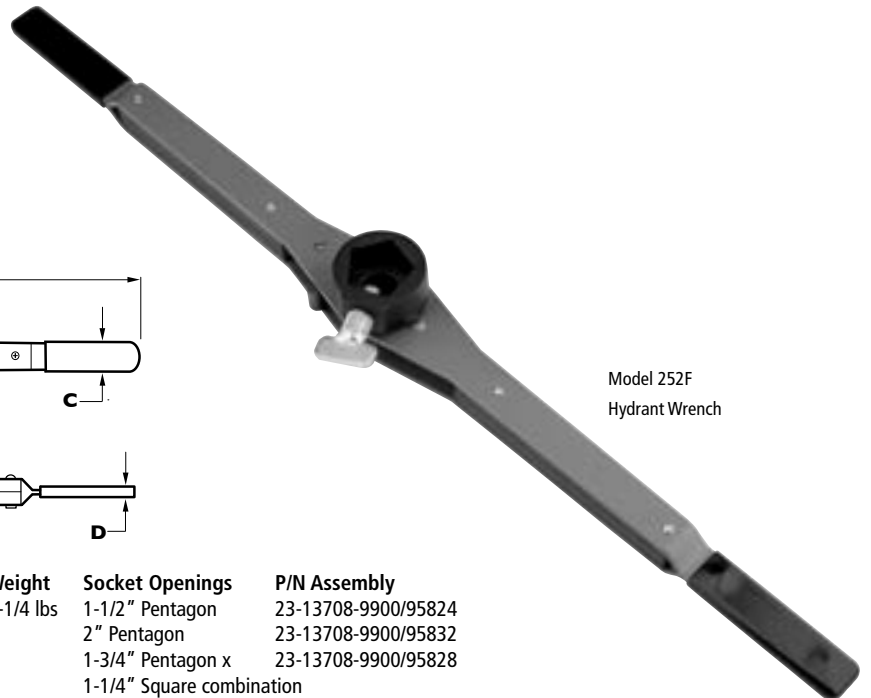

Valve Wheel Wrenches

For added force to turn frozen wheels.

- Rugged cast iron or aluminum
- Large, non-ratcheting extension arms
- End opening has special shape to engage without slipping or marring surfaces

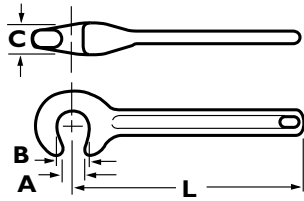

Valve Wheel Wrench

Valve Wheel Wrenches

MODEL	L	A	B	C	Weight	P/N
Cast Iron						
V-0	8"	21/32"	3/4"	1"	1 lb	28678-9908
V-1	15"	1"	1-3/16"	1-3/8"	1-7/8 lbs	28678-9915
V-2	22"	1-5/16"	1-1/2"	2"	7-1/2 lbs	28678-9922
V-3	30"	2"	2-3/16"	2-1/2"	11 lbs	28678-9930
Aluminum						
V-0	8"	21/32"	3/4"	1"	1/4 lb	28678-9808
V-1	14"	1"	1-3/16"	1-3/8"	1 lb	28678-9815
V-2	20-1/2"	1-3/8"	1-1/2"	2"	2-1/8 lbs	28678-9922

Valve Key Socket Set

A better way to engage worn or corroded valve nuts.

- Field-proven to easily engage rounded-over or deformed valve nuts in the toughest situations, even when corrosion is significant.
- Set includes valve key sockets in 3 sizes (small, medium, large), 3" screw and attachment plate in a durable carrying case
- Durable, yellow zinc-plated, hardened steel components
- Low maintenance
- Lower cost than alternative tools
- Compact size
- P/N 23-3 1106-9900
- Weight: 8 lbs.



Strap Wrenches

Warnock for use on highly polished surfaces

Simplex for heavy duty applications

Lightweight Simplex Aluminum for everything else

- Warnock's drop-forged shackle swings away from handle for quick strap adjustment, securely holds strap in closed position and provides extra turning force
- Simplex has unique nose design for powerful grip and conforms to US Federal Spec CGG-W-651, Type V
- Straps made of polyester yarn coated with latex for durability and extra grip
- Custom strap lengths available
- Cast metal handles



Simplex Strap Wrench

Warnock Strap Wrench

Simplex Aluminum Strap Wrench

Strap Wrenches

Model	Handle Length	Strap Width	Strap Length	Turning Capacity	Torque Limit	Weight	P/N Assembly
Warnock							
W-12	12"	1-1/4"	17"	2"	188	1-1/2 lbs	65114
W-1224	12"	1-1/4"	24"	4"	188	1-1/2 lbs	65122-24
W-1230	12"	1-1/4"	30"	6"	188	1-1/2 lbs	65127-30
W-18	18"	1-3/4"	30"	5"	250	3-1/2 lbs	66125
W-1848	18"	1-3/4"	48"	5"	250	3-1/2 lbs	66141-48
W-24	24"	2-1/4"	54"	12"	330	6-1/2 lbs	68145
Simplex							
S-12	12"	1-1/4"	17"	2"	188	1-1/2 lbs	62114
S-1224	12"	1-1/4"	24"	4"	188	1-1/2 lbs	62121-24
S-1230	12"	1-1/4"	30"	6"	188	1-1/2 lbs	62126-30
S-18	18"	1-3/4"	30"	5"	250	3 lbs	63125
S-1848	18"	1-3/4"	48"	10"	250	3 lbs	63141-48
S-24	24"	2 1/4"	54"	12"	330	5 lbs	64145
Simplex Aluminum							
A-6	6"	1/2"	22"	4"	20	1/8 lb	61115
A-12	12"	1-1/4"	17"	2"	188	7/8 lb	62A14
A-18	18"	1-3/4"	30"	5"	250	1-5/8 lbs	63A25
A-24	24"	2-1/4"	54"	12"	330	2-5/8 lbs	64A45

Maintenance

T-Torker® Wrenches

For repetitive jobs requiring identical torque settings

- Highly durable
- Audible overrunning when factory-preset torque is reached
- Torque values accurate to $\pm 10\%$
- Fast, easy one-handed tightening in right-hand direction
- Size and weight designed for hand comfort
- T-shape creates effective leverage
- Flanged reversing collar disengages the ratchet mechanism and locks the tool for conventional backing off and loosening
- All mechanisms are sealed in die-cast handle and lubricated for the normal life of the tool
- Available in three models: utility, industrial, and ratchet-only

Series T-T

For utility applications

- Designed for US-style, No-HUB® cast iron soil pipe installations prescribed by the Cast Iron Soil Pipe Institute
- Factory-preset and sealed to values of 60, 75, 80 lb/in
- 5/16" or 3/8" hexagonal socket hardened to 42-48 Rc is forged on end of drive shaft
- Length 2-1/2" Weight 1 lb.

Series T-TM

For industrial applications

- Designed to accommodate any factory-preset torque limit and variety of shaft-end accessories
- Applications include: production, assembly, inspection, quality control, field service, in-plant set-up and maintenance
- Torque range is 5 – 80 lb-in
- Settings should be in 5 lb-in increments
- Customized shafts available on request
- Length, 1-7/8" Weight, 1 lb.

Series TR

For maintenance applications

These no-torque ratchet T-handle wrenches offers superior design and construction for a variety of applications

- Length, 1-7/8" Weight, 1 lb.

Impakdriver

Easily tighten and loosen frozen fasteners

- Tighten or loosen screws, nuts and bolts with a hammer blow
- Quick, easy, safe
- Rugged construction for long-term reliability
- Prevents expensive and unnecessary damage to fasteners and machinery.
- Available in five different sets, with and without bits and sockets.
- Available bits 3/8" and 1/2" straight, #2 and #4 Phillips
- Hex sockets 9/16", 1/2", 7/16"



Impakdriver

Model	Drive	Contents	Length	Diameter	Bits	Hex Sockets	Weight
0690M	3/8"	Driver	4-7/8"	1-1/4"	None	None	1-1/8 lbs
0690MG	1/2"	Driver	4-7/8"	1-1/4"	None	None	1-1/8 lbs
0065M	3/8"	Set	4-7/8"	1-1/4"	3/8" straight 1/2" straight #2 phillips #4 phillips	None	1-1/2 lbs
0067M	3/8"	Set	4-7/8"	1-1/4"	" "	7/16", 1/2", 9/16"	1-3/4 lbs
0065MG	1/2"	Set	4-7/8"	1-1/4"	" "	None	1-1/2 lbs



Series T-TM



Series T-T



Series TR

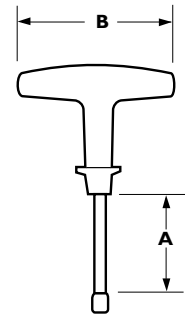

Torque Wrenches

MODEL	No.	Drive Type	A IN	B IN	Torque		Basic Application
					LB-IN	LB	
T-T	3T000	5/16" hex female	2-1/2	4	60 or 75	7/8	Utility
T-T	3T001	3/8" hex female	2-1/2	4	80	7/8	Utility
T-M	3M000	1/4" sq male	1-7/8	4	5 to 80	7/8	Industrial
T-R	3R000	1/4" sq male	1-7/8	4	N/A	7/8	Maintenance

100 Series Crank Handles

For easier more efficient machinery adjustment

- Fixed or rotating metal handle for extra durability
- Rotating plastic handle for lower cost
- Bolt-thru design
- Performs many adjustments including cross feed, rise and fall, gib and quill, positioning screw, or clamping
- Ratchet arm lengths range from 7" to 12"
- Reversing control located in the head to reverse the action safely and easily
- Available in square, hex, bore and keyway, or custom openings

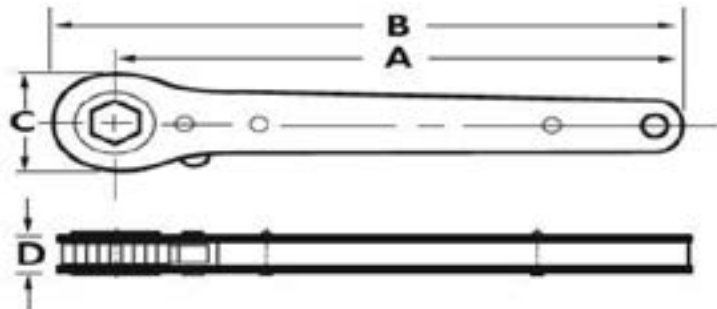

Model	A	B	C	D
101	7"	7-13/16"	1-9/16"	19/32"
103	12"	13-1/2"	2-1/2"	7/8"
112	8"	9"	2-1/16"	7/8"
114	10"	11"	2-1/16"	7/8"
115	12"	13"	2-1/16"	7/8"

More specs and ordering info on next page.

How to order

Add the knob part number to the end of the ratchet arm number to create a crank handle part number.

Example: Model 101 3/8" sq with plastic knob = 82236-4PLR

Crank Handle Knobs

Number	Material	Fixed or Revolving	A	B	C	D
4PLR	Plastic	Rev	1"	2-9/16"	5/8"	
4SLF	Steel	Fix	1"	2-5/32"		
4SLR	Steel	Rev	1"	2-15/16"		5/16"
103F	Steel	Fix	1-3/32"	3-9/16"		
(103 only)						
103R	Steel	Rev	1-3/32"	3-11/32"		5/16"
(103 only)						

Steel

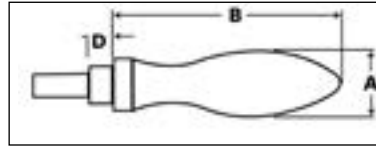

Plastic

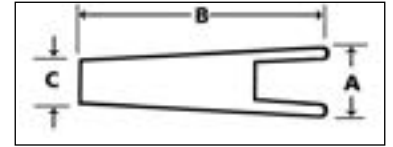

S = Square H = Hex B = Bore

Model 101		Model 103		Model 112		Model 114		Model 115	
Opening	Number	Opening	Number	Opening	Number	Opening	Number	Opening	Number
3/8" S	82236	1/2" S	8L208	1/2" S	81608	1/2" S	83608	1/2" S	84608
1/2" S	82237	5/8" S	8L210	9/16" S	81609	9/16" S	83609	9/16" S	84609
5/8" S	82238	11/16" S	8L211	5/8" S	81610	5/8" S	83610	5/8" S	84610
10 mm S	82S10	3/4" S	8L212	3/4" S	81612	3/4" S	83612	3/4" S	84612
13 mm S	82S13	13/16" S	8L213	13 mm S	81S13	13 mm S	83S13	13 mm S	84S13
16 mm S	82S16	7/8" S	8L214	14 mm S	81S14	14 mm S	83S14	14 mm S	84S14
7/16" H	82357	1" S	8L216	16 mm S	81S16	16 mm S	83S16	16 mm S	84S16
1/2" H	82358	1-1/16" S	8L217	19 mm S	81S19	19 mm S	83S19	19 mm S	84S19
9/16" H	82359	1-1/8" S	8L218	1/2" H	81708	1/2" H	83708	1/2" H	84708
5/8" H	82360	12 mm S	8LS12	9/16" H	81709	9/16" H	83709	9/16" H	84709
3/4" H	82361	13 mm S	8LS13	5/8" H	81710	5/8" H	83710	5/8" H	84710
11 mm H	82H11	14 mm S	8LS14	3/4" H	81712	3/4" H	83712	3/4" H	84712
13 mm H	82H13	16 mm S	8LS16	7/8" H	81714	7/8" H	83714	7/8" H	84714
14 mm H	82H14	17 mm S	8LS17	1" H	81716	1" H	83716	1" H	84716
16 mm H	82H16	19 mm S	8LS19	13 mm H	81H13	13 mm H	83H13	13 mm H	84H13
17 mm H	82H17	22 mm S	8LS22	14 mm H	81H14	14 mm H	83H14	14 mm H	84H14
19 mm H	82H19	25 mm S	8LS25	16 mm H	81H16	16 mm H	83H16	16 mm H	84H16
1/2" B	82178	27 mm S	8LS27	17 mm H	81H17	17 mm H	83H17	17 mm H	84H17
5/8" B	82180	28 mm S	8LS28	19 mm H	81H19	19 mm H	83H19	19 mm H	84H19
3/4" B	82182	3/4" H	8L312	22 mm H	81H22	22 mm H	83H22	22 mm H	84H22
13 mm B	82B13	7/8" H	8L314	25 mm H	81H25	25 mm H	83H25	25 mm H	84H25
16 mm B	82B16	1" H	8L316	1/2" B	81508	1/2" B	83508	1/2" B	84508
19 mm B	82B19	1-1/8" H	8L318	5/8" B	81510	5/8" B	83510	5/8" B	84510
		1-1/4" H	8L320	3/4" B	81512	3/4" B	83512	3/4" B	84512
		19 mm H	8LH19	7/8" B	81514	7/8" B	83514	7/8" B	84514
		22 mm H	8LH22	1" B	81516	1" B	83516	1" B	84516
		25 mm H	8LH25	13 mm B	81B13	13 mm B	83B13	13 mm B	84B13
		28 mm H	8LH28	16 mm B	81B16	16 mm B	83B16	16 mm B	84B16
		32 mm H	8LH32	19 mm B	81B19	19 mm B	83B19	19 mm B	84B19
		3/4" B	8L112	25 mm B	81B25	25 mm B	83B25	25 mm B	84B25
		1" B	8L116						
		1-1/8" B	8L118						
		1-1/4" B	8L120						
		19 mm B	8LB19						
		25 mm B	8LB25						
		28 mm B	8LB28						
		32 mm B	8LB32						

10/10z/40 Series

Basic ratchet arms

- Rugged, cast malleable iron for heavy duty applications
- Enclosed, replaceable gears
- Reversing controls in head
- Wide range of standard and special openings available
- Conform to US Federal Spec GGG-W-653, Type I, Class I
- Gear openings square, hex, bore and keyway
- Slim profile
- Bolt-thru design

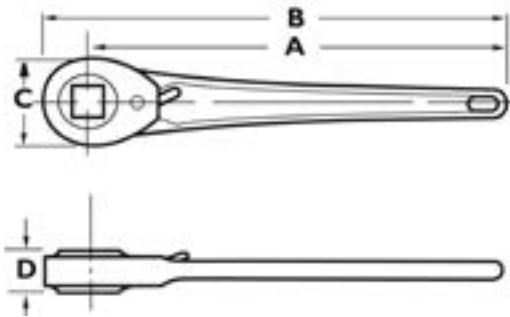

10 Series Ratchet Arms

MODEL	A	B	C	D	E	Weight
11	6"	6-15/16"	1-13/16"	23/32"		1 lb
12	8"	9"	1-15/16"	7/8"		1 lb
13	10"	11"	1-15/16"	7/8"		1-1/2 lbs
14	10"	11-1/4"	2-5/16"	13/16"		1-3/4 lbs
15	12"	13-1/4"	2-5/16"	13/16"		2 lbs
16	15"	16-1/2"	3"	1-7/32"		4-3/4 lbs
17	18"	19-1/2"	3"	1-7/32"		5-1/2 lbs

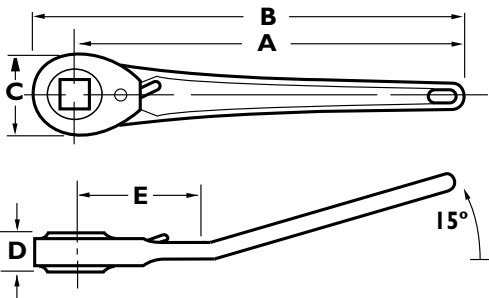

10Z SERIES Ratchet Arms

MODEL	A	B	C	D	E	Weight
11Z	6"	6-15/16"	1-13/16"	23/32"	2-1/2"	1 lb
12Z	8"	9"	1-15/16"	7/8"	2-1/2"	1 lb
13Z	10"	11"	1-15/16"	7/8"	2-1/2"	1-1/2 lbs
14Z	10"	11-1/4"	2-5/16"	13/16"	3"	1-3/4 lbs
15Z	12"	13-1/4"	2-5/16"	13/16"	3"	2 lbs
16Z	15"	16-1/2"	3"	1-7/32"	4"	4-3/4 lbs
17Z	18"	19-1/2"	3"	1-7/32"	4"	5-1/2 lbs

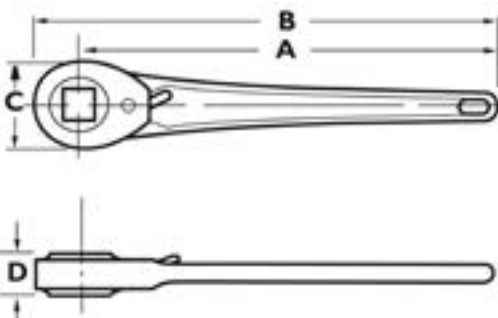

40 SERIES Ratchet Arms

MODEL	A	B	C	D	E	Weight
41	24"	25-7/8"	3-3/4"	1-3/8"		12 lbs
42	36-1/4"	38-1/4"	3-3/4"	1-3/8"		14 lbs
44	36"	38-7/16"	4-7/8"	1-1/2"		16 lbs
45	24"	27"	6-1/8"	1-15/32"		16 lbs
46	38"	41-1/16"	6-1/8"	1-15/32"		25 lbs
47	42"	45-11/16"	7-3/8"	1-3/4"		37 lbs
48	43-9/16"	48"	8-13/16"	1-7/8"		56 lbs

100 Series Ratchet Arms

Low cost reversible arms

- Factory pre-assembled, gears not replaceable
- Riveted stampings
- Slim profile gears with reversing control in head
- Vinyl grip on 112, 114, 115
- Bolt-thru design

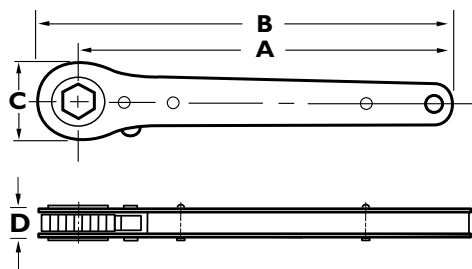

100 SERIES Ratchet Arms

MODEL	A	B	C	D	Weight
101	7"	7-13/16"	1-9/16"	19/32"	3/4 lb
101A	7"	8-1/16"	2-1/16"	19/32"	3/4 lb
101SS	7"	7-13/16"	1-9/16"	19/32"	3/4 lb
103	12"	13-1/2"	2-1/2"	7/8"	2-1/4 lbs
104	15-3/4"	17"	2-1/2"	7/8"	2-3/4 lbs
105	18-3/4"	20"	2-1/2"	7/8"	3 lbs
112	8"	9"	2-1/16"	7/8"	1-1/2 lbs
114	10"	11"	2-1/16"	7/8"	2 lbs
115	12"	13"	2-1/16"	7/8"	2 lbs

More specs and ordering info on page 26.

Model 101SS Ratchet Arm

Perfect for harsh working conditions, exposure to the elements, wash-down environments, areas with caustic chemicals

- All non-corrosive components
- Stainless steel side plates
- Stainless gear
- 16 gear teeth yield 22.5° rotation between clicks
- Stainless ratcheting components
- Plastic spacer
- Sturdy ratchet mechanism reverses with the flick of a lever
- Reversing controls in head
- Bolt-thru design
- Torque limits 80 lb-ft



Model 101SS

Model 104 & 105 Extra Long Ratchet Arms

Provides greater leverage for utility, construction and maintenance workers

- Riveted stampings
- Sturdy ratchet mechanism reverses with the flick of a lever
- Reversing controls in head
- Factory pre-assembled, gears not replaceable
- Vinyl comfort grips
- Bolt-thru design



Model 104

Model 105

20 Series Ratchet Arms

Heavy duty, remote, reversing arms

- Durable for heavy duty applications
- Knurled knob at end of handle operates on half turn for maximum safety and convenience
- Enclosed, replaceable gears
- Reversing controls in head
- Wide range of standard openings and lengths
- Conforms to Federal Spec GGG-W-653, Type I, Class 2
- Bolt-thru design



20 Series

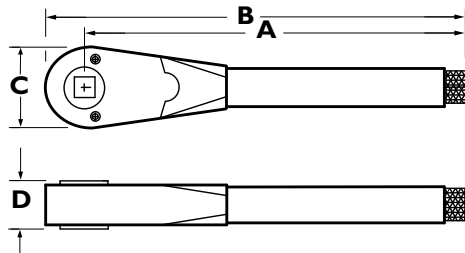

20 SERIES Ratchet Arms

MODEL	A	B	C	D	Weight
21	7-3/8"	8-3/16"	1-9/16"	13/16"	1 lb
22	10-1/2"	11-1/2"	2"	1"	2 lbs
23	12-3/8"	13-9/16"	2-3/8"	1-1/8"	3-1/2 lbs
24	15-9/16"	17-1/8"	3-1/8"	1-7/32"	6-1/4 lbs
25	18-1/2"	20-1/16"	3-1/8"	1-7/32"	6-3/4 lbs
26	18-5/8"	20-9/16"	3-3/4"	1-3/8"	11-7/8 lbs
27	24-5/8"	26-9/16"	3-3/4"	1-3/8"	12 lbs
28	36-13/16"	39-3/16"	4-7/8"	1-1/2"	18 lbs

200 Series Double Handle Ratchet Arms

Light, durable, economical

- Riveted stampings
- Factory pre-assembled, gears not replaceable
- Reversing controls in heads
- Slim profile gears
- Vinyl grips
- Bolt-thru design
- Custom sizes available



Model 203

Model 201

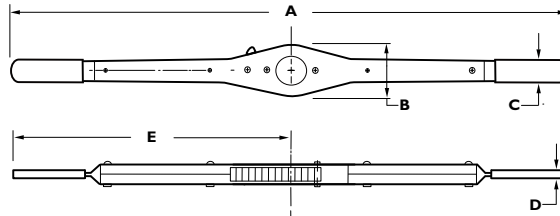

200 Series Ratchet Arms

MODEL	A	B	C	D	E	Weight
201	13-3/4"	1-9/16"	3/4"	5/8"	6-7/8"	1-1/4 lbs
203	19"	2-1/2"	1"	7/8"	9/1/2"	2-1/4 lbs
241	27-5/8"	3-5/8"	1"	7/8"	13-13/16"	41-3/4 lbs

Model 201

Opening	P/N
3/8" S	D1236
1/2" S	D1237
5/8" S	D1238
10 mm S	D1S10
13 mm S	D1S13
16 mm S	D1S16
7/16" H	D1357
1/2" H	D1358
9/16" H	D1359
5/8" H	D1360
3/4" H	D1361
11 mm H	D1H11
13 mm H	D1H13
14 mm H	D1H14
16 mm H	D1H16
17 mm H	D1H17
19 mm H	D1H19
1/2" B	D1178
5/8" B	D1180
3/4" B	D1182
13 mm B	D1B13
16 mm B	D1B16
19 mm B	D1B19

Model 203

Opening	P/N
1/2" S	D2208
5/8" S	D2210
11/16" S	D2211
3/4" S	D2212
13/16" S	D2213
7/8" S	D2214
1" S	D2216
1-1/16" S	D2217
1-1/8" S	D2218
12 mm S	D2S12
13 mm S	D2S13
14 mm S	D2S14
16 mm S	D2S16
17 mm S	D2S17
19 mm S	D2S19
22 mm S	D2S22
25 mm S	D2S25
27 mm S	D2S27
28 mm S	D2S28
3/4" H	D2312
7/8" H	D2314
1" H	D2316
1-1/8" H	D2318
1-1/4" H	D2320
19 mm H	D2H19
22 mm H	D2H22
25 mm H	D2H25
28 mm H	D2H28
32 mm H	D2H32
3/4" B	D2112
1" B	D2116
1-1/8" B	D2118
1-1/4" B	D2120
19 mm B	D2B19
25 mm B	D2B25
28 mm B	D2B28
32 mm B	D2B32

Model 241

Opening	P/N
3/4" S	D4212
7/8" S	D4214
1" S	D4216
1-1/16" S	D4217
1-1/8" S	D4218
1-3/16" S	D4219
1-1/4" S	D4220
1-3/8" S	D4222
1-7/16" S	D4223
1-1/2" S	D4224
19 mm S	D4S19
22 mm S	D4S22
25 mm S	D4S25
27 mm S	D4S27
28 mm S	D4S28
30 mm S	D4S30
32 mm S	D4S32
34 mm S	D4S34
36 mm S	D4S36
38 mm S	D4S38
7/8" H	D4314
1" H	D4316
1-1/16" H	D4317
1-1/8" H	D4318
1-1/4" H	D4320
22 mm H	D4H22
25 mm H	D4H25
28 mm H	D4H28
32 mm H	D4H32
3/4" B	D4212
1" B	D4216
1-13/16" H	D4329
22 mm H	D4H22
25 mm H	D4H25
27 mm H	D4H27
28 mm H	D4H28
30 mm H	D4H30
32 mm H	D4H32

Model 241 (cont)

Opening	P/N
34 mm H	D4H34
36 mm H	D4H36
38 mm H	D4H38
41 mm H	D4H41
42 mm H	D4H42
46 mm H	D4H46
3/4" B	D4112
1" B	D4116
1-1/4" B	D4120
1-3/8" B	D4122
1-1/2" B	D4124
1-3/4" B	D4128
19 mm B	D4B19
25 mm B	D4B25
32 mm B	D4B32
34 mm B	D4B43
38 mm B	D4B38
42 mm B	D4B42

OEM Design

Ratchet Arms

S = Square H = Hex B = Bore P/N HO = Part Number Handle Only

Model	Opening	P/N Gear Only	Model	Opening	P/N Gear Only	Model	Opening	P/N Gear Only	Model	Opening	P/N Gear Only	Model	Opening	P/N Gear Only
11	3/8" S	90206	14	25 mm H	M2725	22	3/8" S	91606	26	1-1/16" H	94317	28	36 mm H	M5336
11Z	1/2" S	90208	14Z	1/2" B	92508	P/NHO	1/2" S	91608	27	1-1/8" H	94318	44	38 mm H	M5338
P/N HO	9/16" S	90209	15	5/8" B	92510		9/16" S	91609	41	1-1/4" H	94320		41 mm H	M5341
	5/8" S	90210	15Z	3/4" B	92512		5/8" S	91610	42	1-3/8" H	94322		42 mm H	M5342
	10 mm S	M0210		7/8" B	92514	22901	10 mm S	M1610		1-7/16" H	94323		46 mm H	M5346
11901	13 mm S	M0213		1" B	92516		13 mm S	M1613		1-1/2" H	94324		47 mm H	M5347
119Z1	14 mm S	M0214		13 mm B	M2513		14 mm S	M1614		1-5/8" H	94326		50 mm H	M5350
	16 mm S	M0216		16 mm B	M2516		16 mm S	M1616		1-3/4" H	94328		55 mm H	M5355
	1/2" H	90308		19 mm B	M2519		1/2" H	91710		1-13/16" H	94329		60 mm H	M5360
	9/16" H	90309		25 mm B	M2525		3/4" H	91712		22 mm H	M4322		1-1/4" B	95120
	5/8" H	90310	16	1/2" S	93208		16 mm H	M1716		25 mm H	M4325		1-3/8" B	95122
	3/4" H	90312	16Z	5/8" S	93210		17 mm H	M1717		27 mm H	M4327		1-1/2" B	95124
	13 mm H	M0313	17	11/16" S	93211		19 mm H	M1719		28 mm H	M4328		1-3/4" B	95128
	14 mm H	M0314	17Z	3/4" S	93212		1/2" B	91508		30 mm H	M4330		1-7/8" B	95130
	16 mm H	M0316	24	7/8" S	93214		3/4" B	91512		32 mm H	M4332		2" B	95132
	17 mm H	M0317	25	1" S	93216		13 mm B	M1513		34 mm H	M4334		2-1/4" B	95136
	19 mm H	M0319	P/N HO	1-1/16" S	93217		19 mm B	M1519		36 mm H	M4336		32 mm B	M5132
	1/2" B	90108		1-1/8" S	93218					38 mm H	M4338		34 mm B	M5143
	5/8" B	90110		13 mm S	M3213	23	1/2" S	92208		41 mm H	M4341		38 mm B	M5138
	3/4" B	90112	16901	16 mm S	M3216	P/N HO	9/16" S	92209		42 mm H	M4342		42 mm B	M5142
	13 mm B	M0113	169Z1	17 mm S	M3217		5/8" S	92210		42 mm H	M4342		47 mm B	M5147
	16 mm B	M0116	17901	19 mm S	M3219	23901	11/16" S	92211		46 mm H	M4346		47 mm B	M5147
	19 mm B	M0119	179Z1	20 mm S	M3220		3/4" S	92212		3/4" B	94112		50 mm B	M5150
12	3/8" S	91206	24901	22 mm S	M3222		13 mm S	M2213		1" B	94116		60 mm B	M5160
12Z	1/2" S	91208	25901	24 mm S	M3224		14 mm S	M2214		1-1/4" B	94120	45	1-7/8" S	96230
13	9/16" S	91209		25 mm S	M3225		16 mm S	M2216		1-3/8" B	94122	46	2" S	96232
13Z	5/8" S	91210		27 mm S	M3227		17 mm S	M2217		1-1/2" B	94124	P/N HO	2-1/4" S	96236
P/N HO	10 mm S	M1210		28 mm S	M3228		19 mm S	M2219		1-3/4" B	94128		2-3/8" S	96238
	13 mm S	M1213		3/4" H	93312		11/16" H	92311		19 mm B	M4119		2-1/2" S	96240
	14 mm S	M1214		7/8" H	93314		3/4" H	92312		25 mm B	M4125	45901	47 mm S	M6247
12901	16 mm S	M1216		1" H	93316		7/8" H	92314		32 mm B	M4132	46901	50 mm S	M6250
129Z1	1/2" H	91308		1-1/8" H	93318		1" H	92316		34 mm B	M4143		60 mm S	M6260
13901	9/16" H	91309		1-1/4" H	93320		17 mm H	M2317		38 mm B	M4138		65 mm S	M6265
139Z1	5/8" H	91310		19 mm H	M3319		19 mm H	M2319		42 mm B	M4142		1-11/16" H	96327
	3/4" H	91312		22 mm H	M3322		22 mm H	M2322	28	1-1/16" S	95217		2-3/8" H	96338
	13 mm H	M1313		24 mm H	M3324		24 mm H	M2324	44	1-1/8" S	95218		2-1/2" H	96340
	14 mm H	M1314		25 mm H	M3325		25 mm H	M2325	P/N HO	1-1/4" S	95220		2-9/16" H	96341
	16 mm H	M1316		27 mm H	M3327		1/2" B	92108		1-3/8" S	95222		2-5/8" H	96342
	17 mm H	M1317		28 mm H	M3328		5/8" B	92110		1-1/2" S	95224		2-3/4" H	96344
	19 mm H	M1319		30 mm H	M3330		3/4" B	92112	28901	1-5/8" S	95226		2-15/16" H	96347
	1/2" B	91108		32 mm H	M3332		1" B	92116	44901	1-3/4" S	95228		3" H	96348
	5/8" B	91110		36 mm H	M3336		13 mm B	M2113		1-13/16" S	95229		3-1/8" H	96350
	3/4" B	91112		3/4" B	93112		16 mm B	M2116		1-7/8" S	95230		3-1/4" H	96352
	13 mm B	M1113		1" B	93116		19 mm B	M2119		2" S	95232		42 mm H	M6342
	16 mm B	M1116		1-1/8" B	93118	26	35 mm B	M2125		27 mm S	M5227		60 mm H	M6360
	19 mm B	M1119		1-1/4" B	93120	27	3/4" S	94212		28 mm S	M5228		65 mm H	M6365
14	1/2" S	92608		19 mm B	M3119	41	7/8" S	94214		32 mm S	M5232		70 mm H	M6370
14Z	9/16" S	92609		25 mm B	M3125	42	1" S	94216		34 mm S	M5234		75 mm H	M6375
15	5/8" S	92610		28 mm B	M3128	P/N HO	1-1/16" S	94217		38 mm S	M5238		80 mm H	M6380
15Z	3/4" S	92612		32 mm B	M3132		1-1/8" S	94218		41 mm S	M5241	47	2-1/8" S	97234
P/N HO	13 mm S	M2613	21	5/16" S	90605		1-3/16" S	94219		42 mm S	M5242	P/N	2-1/2" S	97240
	14 mm S	M2614	P/N HO	3/8" S	90606	26901	1-1/4" S	94220		46 mm S	M5246		2-3/4" S	97244
	16 mm S	M2616		7/16" S	90607	27901	1-3/8" S	94222		47 mm S	M5247		2-7/8" S	97246
14901	19 mm S	M2619		1/2" S	90608	41901	1-7/16" S	94223		50 mm S	M5250	47901	2-15/16" S	97247
149Z1	1/2" H	92708	21901	10 mm S	M0610	42901	1-1/2" S	94224		1-1/4" H	95320		3" S	97248
15901	9/16" H	92709		11 mm S	M0611		19 mm S	M4219		1-7/16" H	95323		3-1/8" S	97250
159Z1	5/8" H	92710		13 mm S	M0613		22 mm S	M4222		1-1/2" H	95324		3-1/4" S	97252
	3/4" H	92712		1/2" H	90708		25 mm S	M4225		1-5/8" H	95326		70 mm S	M7270
	7/8" H	92714		9/16" H	90709		27 mm S	M4227		1-11/16" H	95327		75 mm S	M7275
	1" H	92716		19/32" H	90791		28 mm S	M4228		1-13/16" H	95329		80 mm S	M7280
	13 mm H	M2713		13 mm H	M0713		30 mm S	M4230		1-7/8" H	95330		3-1/4" H	97352
	14 mm H	M2714		14 mm H	M0714		32 mm S	M4232		2" H	95332		3-1/2" H	97356
	16 mm H	M2716		1/2" B	90508		34 mm S	M4234		2-1/8" H	95334		3-3/4" H	97360
	17 mm H	M2717		13 MM B	M0513		36 mm S	M4236		2-3/16" H	95335		3-7/8" H	97362
	19 mm H	M2719					38 mm S	M4238		2-1/4" H	95336		85 mm H	M7385
	22 mm H	M2722					7/8" H	94314		2-3/8" H	95338		90 mm H	M7390
							1" H	94316		32 mm H	M5332		95 mm H	M7395

S = Square H = Hex B = Bore P/N HO = Part Number Handle Only

Model	Opening	P/N Gear Only	Model	Opening	P/N Assy	Model	Opening	P/N Gear Only	Model	Opening	P/N Assy
48	3-1/4" S	98252	101A	7/8" B	82514A	104	1/2" S	L3208	112	19 mm B	81B19
P/N HO	3-1/2" S	98256		1" B	82516A	105	5/8" S	L3210		25 mm B	81B25
	3-3/4" S	98260		13 mm B	82B13A	P/N HO	11/16" S	L3211	114	1/2" S	83608
	3-7/8" S	98262		16 mm B	82B16A		3/4" S	L3212		9/16" S	83609
48901	95 mm S	M8295		19 mm B	82B19A		13/16" S	L3213		5/8" S	83610
	3-7/8" H	98362		25 mm B	82B25A	10401	7/8" S	L3214		3/4" S	83612
	4" H	98364	101SS	3/8" S	82236S	10501	1" S	L3216		13 mm S	83513
	4-1/8" H	98366		1/2" S	82237S		1-1/16" S	L3217		14 mm S	83514
	4-1/4" H	98368		5/8" S	82238S		1-1/8" S	L3218		16 mm S	83516
	4-1/2" H	98372		10 mm S	82S10S		12 mm S	M9612		19 mm S	83519
	4-5/8" H	98374		13 mm S	82S13S		13 mm S	M9613		1/2" H	83708
	100 mm H	N8300		16 mm S	82S16S		14 mm S	M9614		9/16" H	83709
	105 mm H	N8305		7/16" H	82357S		16 mm S	M9616		5/8" H	83710
	110 mm H	N8310		1/2" H	82358S		17 mm S	M9617		3/4" H	83712
	115 mm H	N8315		9/16" H	82359S		19 mm S	M9619		7/8" H	83714
	120 mm H	N8320		5/8" H	82360S		22 mm S	M9622		1" H	83716
	2-3/4" B	98144		3/4" H	82361S		25 mm S	M9625		13 mm H	83H13
	70 mm B	M8170		11 mm H	82H11S		27 mm S	M9627		14 mm H	83H14
				13 mm H	82H13S		28 mm S	M9628		16 mm H	83H16
				14 mm H	82H14S		3/4" H	L3312		17 mm H	83H17
101	3/8" S	82236		16 mm H	82H16S		7/8" H	L3314		19 mm H	83H19
	1/2" S	82237		17 mm H	82H17S		1" H	L3316		22 mm H	83H22
	5/8" S	82238		19 mm H	82H19S		1-1/8" H	L3318		25 mm H	83H25
	10 mm S	82S10		1/2" B	82178S		1-1/4" H	L3320		1/2" B	83508
	13 mm S	82S13		5/8" B	82180S		19 mm H	M9719		5/8" B	83510
	16 mm S	82S16		3/4" B	82182S		22 mm H	M9722		3/4" B	83512
	7/16" H	82357		13 mm B	82B13S		25 mm H	M9725		7/8" B	83514
	1/2" H	82358		16 mm B	82B16S		28 mm H	M9728		1" B	83516
	9/16" H	82359		19 mm B	82B19S		32 mm H	M9732		13 mm B	83B13
	5/8" H	82360		1/2" S	8L208		3/4" B	L3112		16 mm B	83B16
	3/4" H	82361	103	5/8" S	8L210		1" B	L3116		19 mm B	83B19
	11 mm H	82H11		11/16" S	8L211		1-1/8" B	L3118		25 mm B	83B25
	13 mm H	82H13		3/4" S	8L212		1-1/4" B	L3120	115	1/2" S	84608
	14 mm H	82H14		13/16" S	8L213		19 mm B	M9519		9/16" S	84609
	16 mm H	82H16		7/8" S	8L214		25 mm B	M9525		5/8" S	84610
	17 mm H	82H17		1" S	8L216		28 mm B	M9528		3/4" S	84612
	19 mm H	82H19		1-1/16" S	8L217		32 mm B	M9532		13 mm S	84513
	1/2" B	82178		1-1/8" S	8L218					14 mm S	84514
	5/8" B	82180		12 mm S	8LS12	112	1/2" S	81608		16 mm S	84516
	3/4" B	82182		13 mm S	8LS13		9/16" S	81609		19 mm S	84519
	13 mm B	82B13		14 mm S	8LS14		5/8" S	81610		1/2" H	84708
	16 mm B	82B16		16 mm S	8LS16		3/4" S	81612		9/16" H	84709
	19 mm B	82B19		17 mm S	8LS17		13 mm S	81S13		5/8" H	84710
101A	1/2" S	82608A		19 mm S	8LS19		14 mm S	81S14		3/4" H	84712
	9/16" S	82609A		22 mm S	8LS22		16 mm S	81S16		7/8" H	84714
	5/8" S	82610A		25 mm S	8LS25		19 mm S	81S19		1" H	84716
	3/4" S	82612A		27 mm S	8LS27		1/2" H	81708		13 mm H	84H13
	13 mm S	82S13A		28 mm S	8LS28		9/16" H	81709		14 mm H	84H14
	14 mm S	82S14A		3/4" H	8L312		5/8" H	81710		16 mm H	84H16
	16 mm S	82S16A		7/8" H	8L314		3/4" H	81712		17 mm H	84H17
	19 mm S	82S19A		1" H	8L316		7/8" H	81714		19 mm H	84H19
	1/2" H	82708A		1-1/8" H	8L318		1" H	81716		22 mm H	84H22
	9/16" H	82709A		1-1/4" H	8L320		13 mm H	81H13		25 mm H	84H25
	5/8" H	82710A		19 mm H	8LH19		14 mm H	81H14		1/2" B	84508
	3/4" H	82712A		22 mm H	8LH22		16 mm H	81H16		5/8" B	84510
	7/8" H	82714A		25 mm H	8LH25		17 mm H	81H17		3/4" B	84512
	1" H	82716A		28 mm H	8LH28		19 mm H	81H19		7/8" B	84514
	13 mm H	82H13A		32 mm H	8LH32		22 mm H	81H22		1" B	84516
	14 mm H	82H14A		3/4" B	8L112		25 mm H	81H25		13 mm B	84B13
	16 mm H	82H16A		1" B	8L116		1/2" B	81508		16 mm B	84B16
	17 mm H	82H17A		1-1/8" B	8L118		5/8" B	81510		19 mm B	84B19
	19 mm H	82H19A		1-1/4" B	8L120		3/4" B	81512		25 mm B	84B25
	22 mm H	82H22A		19 mm B	8LB19		7/8" B	81514			
	25 mm H	82H25A		25 mm B	8LB25		1" B	81516			
	1/2" B	82508A		28 mm B	8LB28		13 mm B	81B13			
	5/8" B	82510A		32 mm B	8LB32		16 mm B	81B16			
	3/4" B	82512A									

Roller Clutches

For applications demanding high precision motion control

Simple, rugged construction of Lowell roller clutches make them easy to integrate into a variety of new machine designs and plant operation retrofits. Applications include to protect equipment and material, to select speed or power source, to produce or alter motion, and to prevent motion.

- Four types of assembly
 - One Way Sprocket
 - Cam & Ring;
 - Overrunning Clutch
 - Roller/Ratchet Arm
- Torque capacity normally limited only by the contact stresses between the parts
- Standard keyways are per ANSI/ASME B17.1
- Lubrication recommended after every 1200 hours operation
- Custom models available
- 100% made in USA



One Way Sprocket

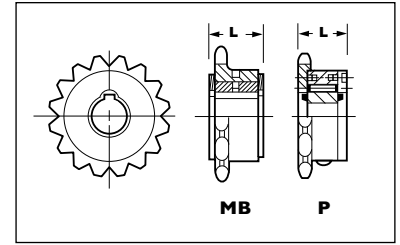

Cam & Ring

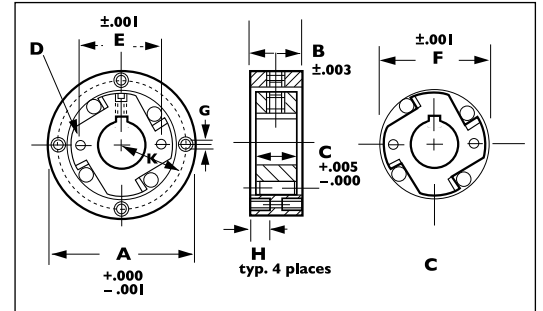

Overrunning

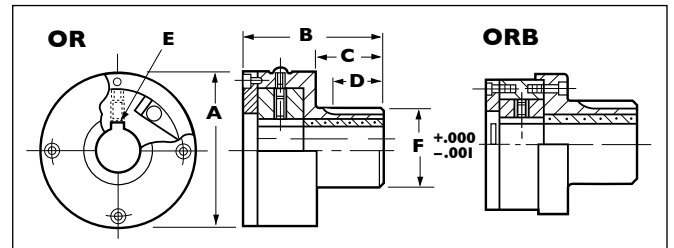

Roller/Ratchet Arm

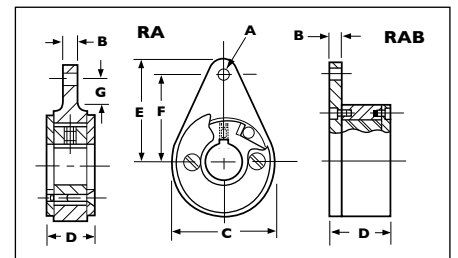

One-Way Sprocket

Cam Size	Max. Bore	Pitch	Number of Teeth		L		Cam Size	Max. Bore	Pitch	Number of Teeth		L	
			MB	P	MB	P				MB	P	MB	P
5	9/16"	35	15,16 +	17 +	13/16"	61/64"	14	5/8"	50	12 +	13 +	13/16"	1-13/64"
14	5/8"	35	20 +	21 +	13/16"	1-11/32"	28	7/8"	50	15, 16 +	17 +	1-1/16"	1-11/32"
28	7/8"	35	25 +	26 +	1-1/16"	1-5/32"	100	1-1/4"	50	20, 21 +	22 +	1-3/8"	1-9/16"
5	9/16"	40	12 +	13 +	13/16"	1-1/16"	14	5/8"	60	12 +	13 +	13/16"	1-21/64"
14	5/8"	40	15 +	16 +	13/16"	1-5/32"	28	7/8"	60	14 +	15 +	1-1/16"	1-29/64"
28	7/8"	40	20 +	21 +	1-1/16"	1-9/32"	100	1-1/4"	60	18 +	19 +	1-3/8"	1-11/16"

Cam & Rg Assembly

Cam Only MODEL	Complete A MODEL	B	C	D	E	F	G	H	K	Bore Openings	Torque lb-ft	Overrun Speed RPM	
C5	CR5	1-1/2"	21/32"	41/64"	9/64"	53/64"	1-1/64"	6-32	7/32"	1-9/32"	1/4"-1/2"	5	1800
C14	CR14	1-7/8"	21/32"	41/64"	9/64"	1-1/8"	1-3/8"	6-32	9/32"	1-11/16"	3/8"-5/8"	14	1800
C28	CR28	2-5/8"	25/32"	49/64"	13/64"	1-27/64"	1-29/32"	8-32	3/8"	2-9/32"	5/8"-7/8"	28	1500
C100	CR100	3-1/2"	1-1/32"	1-1/64"	17/64"	1-7/8"	2-41/64"	10-32	3/8"	3"	3/4"-1-1/4"	100	1000
C200	CR200	4-3/8"	1-5/8"	1-39/64"	17/64"	2-21/32"	3-9/32"	1/4"-20	7/16"	3-13/16"	1-1/2"-2"	200	800
C500	CR500	5-7/8"	1-51/64"	1-25/32"			4-9/16"	5/16"-18	1/2"	5-1/4"	2-1/4"-2-3/4"	500	600

Overrunning Clutch

MODEL	A	B	C	D	E	F	G	H	Bore Opengs	Torque lb-ft	Overrun Speed RPM
OR5	1-5/8"	1-15/16"	13/16"	7/16"	3/16" x 3/32"	7/8"	41/64"	1-1/16"	1/4"-1/2"	5	1800
OR14	2"	2-1/8"	1"	9/16"	3/16" x 3/32"	1-1/4"	41/64"	1-3/16"	3/8"-5/8"	14	1800
OR28	2-5/8"	2-23/32"	15/16"	1-5/16"	3/16" x 3/32"	1-3/8"	49/64"	1-3/4"	5/8"-7/8"	28	1500
OR100	3-3/8"	3-1/16"	1 7/16"	1"	1/4" x 1/8"	1-3/4"	1-1/64"	1-3/4"	3/4"-1"	100	1000
ORB100	3-5/8"	3-11/32"	1-1/2"	13/16"	3/8" x 3/16"	2-1/4"	1-1/64"	2"	3/4"-1-1/4"	100	1000
ORB200	4-1/2"	4-1/2"	2-1/16"	1-5/16"	3/8" x 3/16"	3"	1-39/64"	2-1/2"	1-1/2"-2"	200	800
ORB500	6"	5-5/32"	2-1/2"	2"	1/2" x 1/4"	4-1/2"	1 25/32"	3"	2-1/4"-2-3/4"	500	600

Roller Arm Assembly

MODEL	A	B	C	D	E	F	G	Bore Openings	Torque lb-ft	Overrun Speed RPM
RA14	1/4"	1/4"	1-7/8"	13/16"	1-3/4"	1-1/2"	7/16"	3/8"-5/8"	14	1800
RA100	5/16"	5/16"	3-3/4"	1-3/8"	3-7/16"	3"	1"	3/4"-1-1/4"	100	1000
RAB200	13/32"	3/8"	4-1/2"	2-3/8"	4-1/4"	3-5/8"		1-1/2"-2"	200	800
RAB500	17/32"	3/8"	6"	2-17/32"	5-1/2"	4-3/4"		2-1/4"-2-3/4"	500	600

70 Series Ratchet Clutches

Rugged and reliable for heavy-duty applications

Lowell ratchet clutches are designed from standard bodies, gears, pawls, and springs. Forces are applied in an optimum manner between the solid steel gear and hefty pawl so that loads are in compression rather than in shear. Gears are a low-carbon steel. Rugged tooth design has large contact area with pawl.

- Mounting holes provided in body
- Keyways are per ANSI/ASME B17.1
- Lubrication is recommended after every 1200 hours of operation
- Specials may be ordered with size, shape, and tooth arrangements of your choice
- Fully locked neutral position
- Free running neutral position available on request
- Durable, cast iron construction
- Custom models available
- 100% made in USA



700 Series Ratchet Clutches

Low cost and weight with high performance

- Fingertip control of motion: one-way clockwise and one-way counter clockwise
- Control lever can be connected to hydraulic, pneumatic, or electric actuators for remote shifting
- Simple design ensures durability and reduces purchase and operating costs
- High drive torque-to-weight ratio
- Maximum driving efficiency
- Minimal overrunning torque
- Versatile mounting options
- Standard gear openings available in hex, square, and bore and keyway (per ANSI/ASME B17.1)
- Can be used singly or in combination
- Open sided for easy, minimal maintenance
- Alignment is not critical
- 100% made in USA



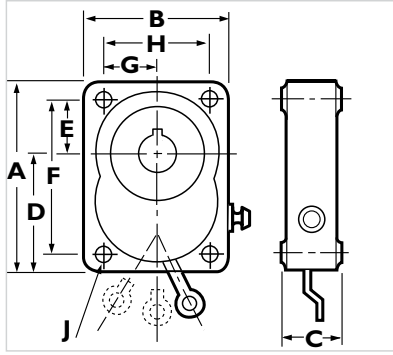

70 Series Clutches

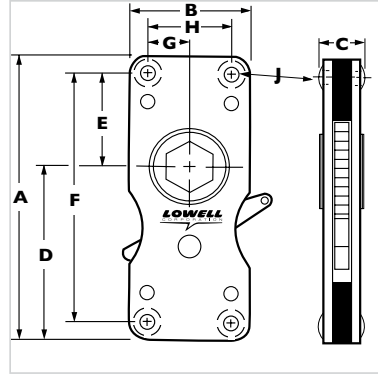

700 Series Clutches

70 SERIES Ratchet Clutches

MODEL	A	B	C	D	E	F	G	H	J	Weight	Max Torque lb-ft	Overrun Speed rpm	Gear Teeth
71	2-7/8"	2-3/8"	15/16"	1-3/4"	13/16"	2-1/4"	7/8"	1-3/4"	17/64"	1-1/2 lbs	200	250 rpm	16
72	3-1/4"	2-7/8"	1-3/16"	1-7/8"	1-1/16"	2-5/8"	1-1/8"	2-1/4"	19/64"	2-1/4 lbs	300	100 rpm	16
73	4"	3-1/3"	1-5/16"	2-7/16"	1-3/16"	3-1/4"	1-3/16"	2-3/8"	21/64"	3-1/2 lbs	500	100 rpm	20
74	5-1/8"	3-7/8"	1-7/16"	3-1/8"	1-1/2"	4-1/8"	1-7/16"	2-7/8"	25/64"	6-1/4 lbs	800	75 rpm	20
75	6-1/2"	5"	1-9/16"	4"	1-7/8"	5-1/4"	1-7/8"	3-3/4"	17/32"	11 lbs	1500	60 rpm	24
76	8-3/8"	6-1/4"	1-7/16"	5-1/2"	2-1/2"	7-1/8"	2-1/2"	5"	17/32"	15 lbs	2500	50 rpm	24
77	9-3/4"	7-1/2"	1-1/2"	6"	3-1/8"	8-7/16"	3-1/8"	6-1/4"	17/32"	24 lbs	4100	50 rpm	24
78	10-7/8"	8-3/8"	1-15/16"	6-1/2"	3-5/8"	9-3/8"	3-7/16"	6-7/8"	17/32"	29 lbs	6260	30 rpm	24

700 SERIES Ratchet Clutches

701	4"	15/8"	21/32"	2-7/16"	1-21/64"	3-1/2"	9/16"	1-1/8"	3/16"	3/4 lb	85	250 rpm	16
702	5-1/4"	2-3/8"	61/64"	3-5/8"	1-1/4"	4-1/2"	13/16"	1-5/8"	17/64"	1-1/2 lbs	175	100 rpm	20

additional specs and ordering info on following page

S = Square H = Hex B = Bore P/N BO = Part Number, Body Only

Series 70 Clutches

Model	Opening	P/N Gear Only	Model	Opening	P/N Gear Only
71	3/8" S	91206	73	25 mm S	M3225
	1/2" S	91208		27 mm S	M3227
P/N BO	9/16" S	91209		28 mm S	M3228
	5/8" S	91210		3/4" H	93312
	10 mm S	M1210		7/8" H	93314
71901	13 mm S	M1213		1" H	93316
	14 mm S	M1214		1-1/8" H	93318
	16 mm S	M1216		1-1/4" H	93320
	1/2" H	91308		19 mm H	M3319
	9/16" H	91309		22 mm H	M3322
	5/8" H	91310		24 mm H	M3324
	3/4" H	91312		25 mm H	M3325
	13 mm H	M1313		27 mm H	M3327
	14 mm H	M1314		28 mm H	M3328
	16 mm H	M1316		30 mm H	M3330
	17 mm H	M1317		32 mm H	M3332
	19 mm H	M1319		36 mm H	M3336
	1/2" B	91108		3/4" B	93112
	5/8" B	91110		1" B	93116
	3/4" B	91112		1-1/8" B	93118
	13 mm B	M1113		1-1/4" B	93120
	16 mm B	M1116		19 mm B	M3119
	19 mm B	M1119		25 mm B	M3125
72	1/2" S	92208		28 mm B	M3128
	9/16" S	92209		32 mm B	M3132
P/N BO	5/8" S	92210	74	3/4" S	94212
	11/16" S	92211		7/8" S	94214
	3/4" S	92212	P/N BO	1" S	94216
72901	13 mm S	M2213		1-1/16" S	94217
	14 mm S	M2214		1-1/8" S	94218
	16 mm S	M2216		1-3/16" S	94219
	17 mm S	M2217		1-1/4" S	94220
	19 mm S	M2219		1-3/8" S	94222
	11/16" H	92311		1-7/16" S	94223
	3/4" H	92312		1-1/2" S	94224
	7/8" H	92314		19 mm S	M4219
	1" H	92316		22 mm S	M4222
	17 mm H	M2317		25 mm S	M4225
	19 mm H	M2319		27 mm S	M4227
	22 mm H	M2322		28 mm S	M4228
	24 mm H	M2324		30 mm S	M4230
	25 mm H	M2325		32 mm S	M4232
	1/2" B	92108		34 mm S	M4234
	5/8" B	92110		36 mm S	M4236
	3/4" B	92112		38 mm S	M4238
	1" B	92116		7/8" H	94314
	13 mm B	M2113		1" H	94316
	16 mm B	M2116		1-1/16" H	94317
	19 mm B	M2119		1-1/8" H	94318
	35 mm B	M2125		1-1/4" H	94320
73	1/2" S	93208		1-3/8" H	94322
	5/8" S	93210		1-7/16" H	94323
P/N BO	11/16" S	93211		1-1/2" H	94324
	3/4" S	93212		1-5/8" H	94326
	7/8" S	93214		1-3/4" H	94328
73901	1" S	93216		1-13/16" H	94329
	1-1/16" S	93217		22 mm H	M4322
	1-1/8" S	93218		25 mm H	M4325
	13 mm S	M3213		27 mm H	M4327
	16 mm S	M3216		28 mm H	M4328
	17 mm S	M3217		30 mm H	M4330
	19 mm S	M3219		32 mm H	M4332
	20 mm S	M3220		34 mm H	M4334
	22 mm S	M3222		36 mm H	M4336
	24 mm S	M3224		38 mm H	M4338
				41 mm H	M4341

Series 700 Clutches

Model	Opening	P/N Gear Only	Model	Opening	P/N Gear Only
74	42 mm H	M4342	75	42 mm B	M5142
	46 mm H	M4346		47 mm B	M5147
	3/4" B	94112		50 mm B	M5150
	1" B	94116		60 mm B	M5160
	1-1/4" B	94120	76	1-7/8" S	96230
	1-3/8" B	94122		2" S	96232
	1-1/2" B	94124	P/N BO	2-1/4" S	96236
	1-3/4" B	94128		2-3/8" S	96238
	19 mm B	M4119		2-1/2" S	96240
	25 mm B	M4125	76901	47 mm S	M6247
	32 mm B	M4132		50 mm S	M6250
	34 mm B	M4143		60 mm S	M6260
	38 mm B	M4138		65 mm S	M6265
	42 mm B	M4142		1-11/16" H	96327
75	1-1/16" S	95217		2-3/8" H	96338
	1-1/8" S	95218		2-1/2" H	96340
P/N BO	1-1/4" S	95220		2-9/16" H	96341
	1-3/8" S	95222		2-5/8" H	96342
	1-1/2" S	95224		2-3/4" H	96344
75901	1-5/8" S	95226		2-15/16" H	96347
	1-3/4" S	95228		3" H	96348
	1-13/16" S	95229		3-1/8" H	96350
	1-7/8" S	95230		3-1/4" H	96352
	2" S	95232		42 mm H	M6342
	27 mm S	M5227		60 mm H	M6360
	28 mm S	M5228		65 mm H	M6365
	32 mm S	M5232		70 mm H	M6370
	34 mm S	M5234		75 mm H	M6375
	38 mm S	M5238		80 mm H	M6380
	41 mm S	M5241	77	2-1/8" S	97234
	42 mm S	M5242		2-1/2" S	97240
	46 mm S	M5246	P/N BO	2-3/4" S	97244
	47 mm S	M5247		2-7/8" S	97246
	50 mm S	M5250		2-15/16" S	97247
	1-1/4" H	95320	77901	3" S	97248
	1-7/16" H	95323		3-1/8" S	97250
	1-1/2" H	95324		3-1/4" S	97252
	1-5/8" H	95326		70 mm S	M7270
	1-11/16" H	95327		75 mm S	M7275
	1-13/16" H	95329		80 mm S	M7280
	1-7/8" H	95330		3-1/4" H	97352
	2" H	95332		3-1/2" H	97356
	2-1/8" H	95334		3-3/4" H	97360
	2-3/16" H	95335		3-7/8" H	97362
	2-1/4" H	95336		85 mm H	M7385
	2-3/8" H	95338		90 mm H	M7390
	32 mm H	M5332		95 mm H	M7395
	36 mm H	M5336	78	3-1/4" S	98252
	38 mm H	M5338		3-1/2" S	98256
	41 mm H	M5341	P/N BO	3-3/4" S	98260
	42 mm H	M5342		3-7/8" S	98262
	46 mm H	M5346		95 mm S	M8295
	47 mm H	M5347	78901	3-7/8" H	98362
	50 mm H	M5350		4" H	98364
	55 mm H	M5355		4-1/8" H	98366
	60 mm H	M5360		4-1/4" H	98368
	1-1/4" B	95120		4-1/2" H	98372
	1-3/8" B	95122		4-5/8" H	98374
	1-1/2" B	95124		100 mm H	N8300
	1-3/4" B	95128		105 mm H	N8305
	1-7/8" B	95130		110 mm H	N8310
	2" B	95132		115 mm H	N8315
	2-1/4" B	95136		120 mm H	N8320
	32 mm B	M5132		2-3/4" B	98144
	34 mm B	M5143		70 mm B	M8170
	38 mm B	M5138			

Observation Windows

For trouble-free visual inspection

- Solid, shock-resistant transparent acrylic
- Withstands temperatures up to 158° F
- Withstands internal pressures up to 8.8 psi or higher with optional guard ring
- Removable film protects polished face from damage during delivery and assembly
- White reflectors are furnished with all windows up to 8-inch diameter and are removable if not desired

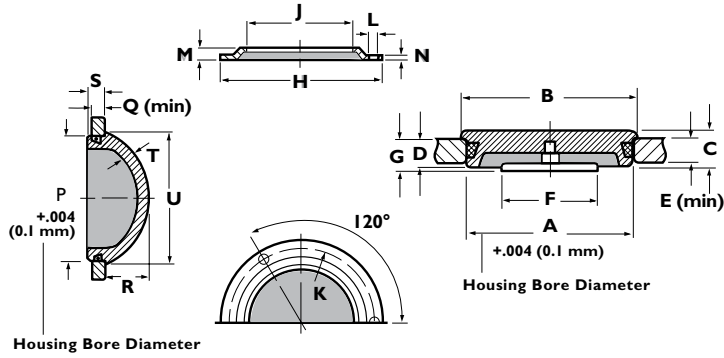

Oil Window

MODEL	ØA		ØB		C	D	E (min)	Reflector		G				
	IN	MM	IN	MM				IN	MM		IN	MM		
14200	7/8	22,2	1	25	11/32	8,5	9/32	7	7/32	5	3/4		13/32	10
20200	1-1/4		1-3/8		11/32		9/32		7/32		1-1/8		13/32	
21200		32		35		8,5		7		5	28			10
24200	1-1/2	38,1	1-5/8	41	11/32	8,5	9/32	7	7/32	5	1-1/8	28	13/32	10
32200	1-31/32	50	2-1/8	53	13/32	10	11/32	8,5	1/4	6	1-1/8	28	13/32	10
48200	2-59/64	75	3-1/16	76	13/32	10	11/32	8,5	1/4	6	1-1/8	28	13/32	10
64200	3-15/16	100	4-1/16	103	13/32	10	11/32	8,5	1/4	6	1-1/8	28	13/32	10
95200	5-29/32	150	6	153	13/32	10	11/32	8,5	1/4	6	1-1/8	28	13/32	10
96100	7-7/8	200	7-63/64	203	13/32	10	11/32	8,5	1/4	6				
97100	9-27/32	250	9-61/64	253	1/2	12	13/32	10	10/32	8				
98100	11-57/64	300	11-59/64	303	20/32	15	1/2	12	13/32	10				

Guard Ring for Push Fit Oil Windows

MODEL	ØH		ØJ		ØK		ØL		M	N	Use With		
	IN	MM	IN	MM	IN	MM	IN	MM					
44600	2-3/4	69	1-13/16	46	2-31/64	63	9/64	3,6	1/8	3,2	1/32	0,8	32200
62600	3-7/8	98	2-3/4	70	3-35/64	90	3/16	4,8	1/8	3,2	3/64	1	48200
78600	4-7/8	123	3-3/4	95	4-17/32	115	3/16	4,8	1/8	3,2	3/64	1	64200

Oil Circulation Indicator

MODEL	ØP		Q (min)		R	S	T	ØU				
	IN	MM	IN	MM				IN	MM			
24700	1-1/2	38,1	7/32	5	2-7/32	21	9/32	7	7/32	5	1-5/8	41
47700		75		6		30		8,5		5		80
48700	3		1/4		1-3/16		11/32		7/32		3-3/16	

Parts

Repair Parts

Complete kits are available for many of our ratchet arms, clutches and socket wrenches

20 Series Ratchet arms

For 20 Series Ratchet Arms

- Kit contains 2 pawls, 2 pawl springs, 1 shifter screw, 1 rod spring



Cover Plate Kits

For 1-20-40 Series Ratchet Arms

70 Series Ratchet Clutches

- Kit contains 1 cover plate, 1 or more cover screws



Socket Wrench Cover Plate Kit

For 50 Series Socket Wrenches

- Kit contains 1 cover plate, 1 cover spacer, 1 snap ring, 1 or more cover screws



QR Socket Wrench Cover Plate Kit

For 50 Series Socket Wrenches

Quick Release (QR) Series Socket Wrenches

- Kit contains 1 cover plate, 1 cover spacer, 1 cover screw, 1 latch, 2 latch springs

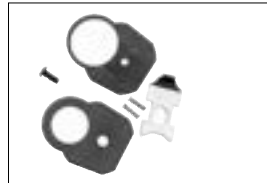

Rod and Knurl Kit

For 20 Series Ratchet Arms

- Kit contains 1 rod and knurl assembly, 1 shifter screw, 1 rod spring

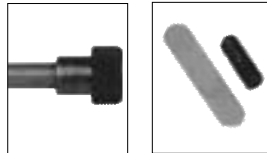

Complete Kit

For 10 and 40 Series Ratchet Arms, 70 Series Ratchet Clutches, 50 Series Socket Wrenches, Quick Release (QR) Series Socket Wrenches

- Kit contains 2 pawls, 2 pawl springs, 1 shifter screw, 1 shifter



Custom Parts

Extensive capabilities for modifying an existing product or engineering a new one

- Alter the shape of a drive
- Alter the size of a drive
- Change the number of teeth on a gear
- Add a free-running neutral
- Handle modifications
 - Shorten
 - Lengthen
 - Bend
 - Off-set
 - Hinge
 - Reposition mounting configurations
- New design from detailed drawing to sample fabrication to manufacturing

Contact the Lowell Engineering Dept. or your local distributor to discuss your application.





Distributed by:

This catalog supersedes all previously published literature. Products not shown herein have been discontinued. Contact factory for possible availability of any product not shown. All details of manufacture are given without obligation. Tolerances are in accordance with ANSI/ASME. We reserve the right to amend or approve the products for technical reasons. Weights given are average, and we are not bound by the weights quoted.

Warranty

Lowell's products are guaranteed against defects in material and workmanship for a period of one year after installation so long as date of installation is less than 24 months after date of manufacture. The Lowell Corporation certifies that Lowell T-Torkers have been calibrated to an accuracy of plus or minus ten percent of the torque value stamped on the tool. These are delicate instruments. Do not use them as hammers. This Warranty will be void if there is any evidence of using these tools as a hammer. These tools are guaranteed to be free from defects in material and workmanship for a period of one year from the date of sale, provided they are used as torque instruments.

THERE ARE NO OTHER WARRANTIES, EXPRESS OR IMPLIED, WHETHER OF MERCHANTABILITY, FITNESS FOR USE, OR OTHERWISE.

Lowell shall have no liability for defects until the goods are returned to it with its permission. Buyer's exclusive remedy shall be the replacement, correction or refund of the purchase price of the defective part, at Lowell's option. In no event shall Lowell be liable for incidental or consequential damages for any cause whatsoever, whether breach of warranty or otherwise.



Making tough jobs easier since 1869

Lowell Corporation
65 Hartwell Street
West Boylston, MA 01583 USA

508/835-2900 800/456-9355
fax 508/835-2944

www.lowellcorp.com
customerservice@lowellcorp.com

