

INTRODUCTION

WARNING

Please follow these installation instructions carefully in order to avoid a safety hazard and/or injury.

- “Risk of damage to appliance”. The neutralizer kit inlet and discharge must be at a lower elevation than the condensate drain from appliance.
- Do **NOT** allow exhaust flue gases to vent through the neutralizer kit. All condensate drains must have a trap to prevent flue gas leakage. Flue gas leakage can cause injury or death from carbon monoxide.
- Connection to the appliance and neutralizer kit must be installed to ensure that no condensate backflow can occur into the appliance.
- Do not connect more than ONE appliance to the neutralizer kit.

DIMENSIONS AND INCLUDED PARTS

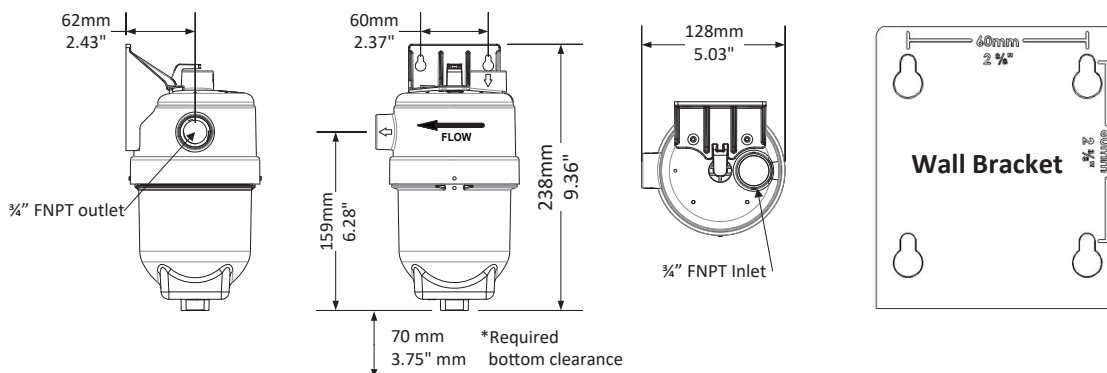

SPECIFICATIONS

Condensate Neutralizer Kit Part No.: GXXX002212

Replacement Media Part No.: GXXX001323

Max Flow Rate: 1.6 gph (6.05 lph)

Weight: 4.0 lbs (2.0 +/- 5% kgs)

Condensate Neutralizer Kit Includes:

- One (1) corrosion-resistant neutralizer housing with 4" fill/access openings (0.26 gallon / 1 liter volume) with 3/4"- 14 FNPT threaded INLET and OUTLET connections
- One (1) 1/2" FNPT x 1/2" PVC Socket Weld Adapter
- Two (2) 3/4" MNPT x 1/2" PVC Socket Weld Adapters
- One (1) Wall Mounting Bracket with Screws

OPERATION

- The appliance condensate will flow through the neutralizing media, raising the pH of the condensate to a level that will help prevent corrosion of the domestic drain and the public sewer system.

PREPARE FOR INSTALLATION

NOTE: Connections to the appliance and neutralizer kit must be installed to ensure that no condensate backflow can occur. Connect corrosion resistant piping and secure it to the floor or wall to prevent movement and/or damage.

- Open the capsule and ensure media is level inside. If necessary, the orientation of the neutralizer can be reversed by removing the wall bracket and moving it to the other side of the lid (see Figure 1 on next page).
- The INLET has a top connection port and the OUTLET has a side connection. Mount the neutralizer unit on the wall by securing it with the provided bracket (see INCLUDED PARTS section above).

INSTALLATION (continued)

- Mount as per the installation diagram below (see Figure 1). Check that the neutralizer is upright in the proper position as shown in the above diagram. The neutralizer should be installed after the trap. Ensure that the condensate will flow freely from the appliance drain into the neutralizer then to an approved drain by applying sufficient slope to the drain pipe.
- Access to the discharge is necessary for proper maintenance in order to check the effectiveness of the neutralizing media using pH test strips.
- If there is no gravity drain available, install a condensate removal pump designed for use on condensing boilers and water heaters. The condensate pump must be equipped with an overflow switch to prevent operation of the appliance due to failure.
- The float should be down during normal operation (see Figure 2). If flow in the neutralizer becomes restricted, the float will rise and lock in position, indicating that the media should be cleaned or replaced (see Figure 3). After replacing the media, reset the float by pressing it back to the down position.

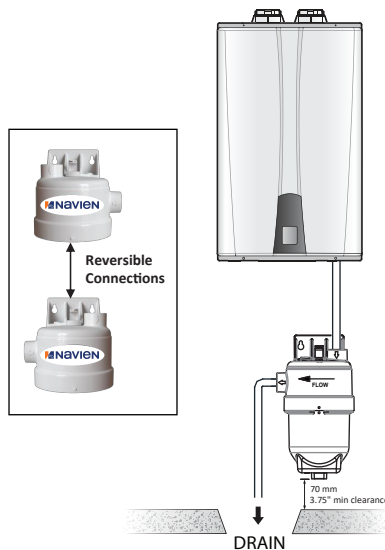

Figure 1: Standard Installation Example

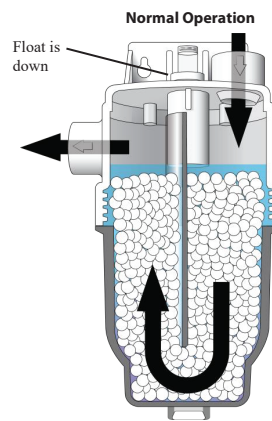

Figure 2: Direction of Condensate Flow at Normal Operation (Float in DOWN position)

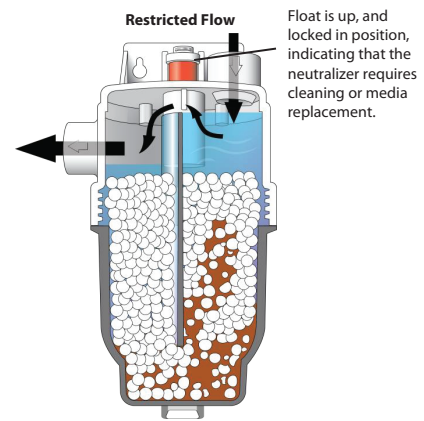

Figure 3: Imbalance Due to Restricted Flow (Float in UP position)

MAINTENANCE

- Monitor the cleanliness, level of the neutralization media, and pH level in the neutralizer monthly. Remove any precipitate coating or debris found to prevent blockages. Check the pH level at the outlet of the neutralizing kit using a suitable pH test strip paper or an electronic pH meter for precise measurement. The neutralizing media should be replaced when the pH level drops below the minimum level of the local water authority, when the float rises (see Figure 3 above), or after one (1) year, whichever comes first. For replacement media, contact your local Navien distributor.

LIMITED WARRANTY

- The unit is warranted against defects in materials and workmanship for **ONE YEAR**. The warranty does NOT cover issues that result from misuse, improper installation, and/or failure to replace the media.

WARNING

This product can expose you to crystalline silica (airborne particles of respirable size) which is known in the state of California to cause cancer. For more information go to www.P65Warnings.ca.gov