

# Installation, Operation, and Maintenance

## Packaged Rooftop Air Conditioners Foundation™ Electric/Electric 15 – 25 Tons, 380V

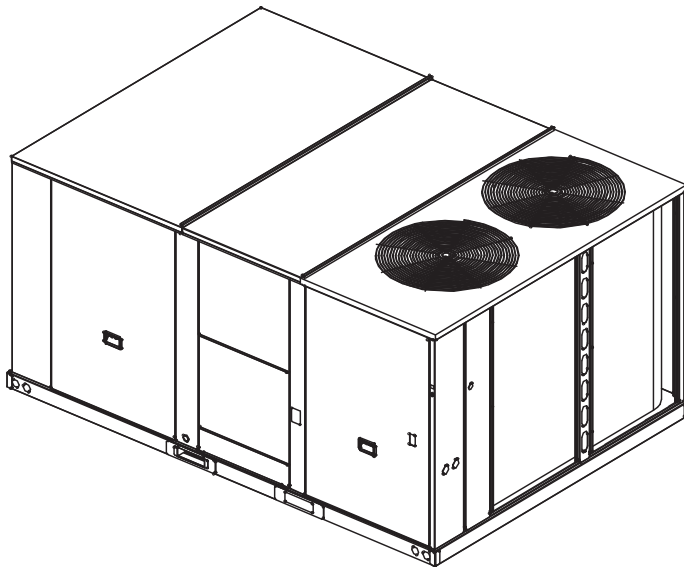

Model Numbers:

EAC180-300AK

### **⚠ SAFETY WARNING**

Only qualified personnel should install and service the equipment. The installation, starting up, and servicing of heating, ventilating, and air-conditioning equipment can be hazardous and requires specific knowledge and training. Improperly installed, adjusted or altered equipment by an unqualified person could result in death or serious injury. When working on the equipment, observe all precautions in the literature and on the tags, stickers, and labels that are attached to the equipment.

September 2014

RT-SVX052A-EN

**IR** Ingersoll Rand

# Introduction

Read this manual thoroughly before operating or servicing this unit.

## Warnings, Cautions, and Notices

Safety advisories appear throughout this manual as required. Your personal safety and the proper operation of this machine depend upon the strict observance of these precautions.

---

The three types of advisories are defined as follows:

**⚠ WARNING** Indicates a potentially hazardous situation which, if not avoided, could result in death or serious injury.

**⚠ CAUTION** Indicates a potentially hazardous situation which, if not avoided, could result in minor or moderate injury. It could also be used to alert against unsafe practices.

**NOTICE** Indicates a situation that could result in equipment or property-damage only accidents.

---

## Important Environmental Concerns

Scientific research has shown that certain man-made chemicals can affect the earth's naturally occurring stratospheric ozone layer when released to the atmosphere. In particular, several of the identified chemicals that may affect the ozone layer are refrigerants that contain Chlorine, Fluorine and Carbon (CFCs) and those containing Hydrogen, Chlorine, Fluorine and Carbon (HCFCs). Not all refrigerants containing these compounds have the same potential impact to the environment. Trane advocates the responsible handling of all refrigerants-including industry replacements for CFCs such as HCFCs and HFCs.

## Important Responsible Refrigerant Practices

Trane believes that responsible refrigerant practices are important to the environment, our customers, and the air conditioning industry. All technicians who handle refrigerants must be certified. The Federal Clean Air Act (Section 608) sets forth the requirements for handling, reclaiming, recovering and recycling of certain refrigerants and the equipment that is used in these service procedures. In addition, some states or municipalities may have additional requirements that must also be adhered to for responsible management of refrigerants. Know the applicable laws and follow them.

### ⚠ WARNING

#### Proper Field Wiring and Grounding Required!

Failure to follow code could result in death or serious injury. All field wiring **MUST** be performed by qualified personnel. Improperly installed and grounded field wiring poses **FIRE** and **ELECTROCUTION** hazards. To avoid these hazards, you **MUST** follow requirements for field wiring installation and grounding as described in NEC and your local/state electrical codes.

### ⚠ WARNING

#### Personal Protective Equipment (PPE) Required!

Installing/servicing this unit could result in exposure to electrical, mechanical and chemical hazards.

- Before installing/servicing this unit, technicians **MUST** put on all PPE required for the work being undertaken (Examples; cut resistant gloves/sleeves, butyl gloves, safety glasses, hard hat/bump cap, fall protection, electrical PPE and arc flash clothing). **ALWAYS** refer to appropriate Material Safety Data Sheets (MSDS)/Safety Data Sheets (SDS) and OSHA guidelines for proper PPE.
- When working with or around hazardous chemicals, **ALWAYS** refer to the appropriate MSDS/SDS and OSHA/GHS (Global Harmonized System of Classification and Labelling of Chemicals) guidelines for information on allowable personal exposure levels, proper respiratory protection and handling instructions.
- If there is a risk of energized electrical contact, arc, or flash, technicians **MUST** put on all PPE in accordance with OSHA, NFPA 70E, or other country-specific requirements for arc flash protection, **PRIOR** to servicing the unit. **NEVER PERFORM ANY SWITCHING, DISCONNECTING, OR VOLTAGE TESTING WITHOUT PROPER ELECTRICAL PPE AND ARC FLASH CLOTHING. ENSURE ELECTRICAL METERS AND EQUIPMENT ARE PROPERLY RATED FOR INTENDED VOLTAGE.**

Failure to follow instructions could result in death or serious injury.

**⚠ WARNING**

**Proper Field Wiring and Grounding Required!**

All field wiring **MUST** be performed by qualified personnel. Improperly installed and grounded field wiring poses **FIRE** and **ELECTROCUTION** hazards. To avoid these hazards, you **MUST** follow requirements for field wiring installation and grounding as described in **NEC** and your local/state electrical codes. Failure to follow code could result in death or serious injury.

**NOTICE:**

**Water Damage!**

Non-factory penetrations through the base of this unit are not allowed. Any penetration in the base of the unit may affect the water tight integrity of the unit and lead to water leaks into the conditioned space. Failure to follow instructions could result in equipment and property damage.

**Overview of Manual**

**Note:** *One copy of this document ships inside the control panel of each unit and is customer property. It must be retained by the unit's maintenance personnel.*

This booklet describes proper installation, operation, and maintenance procedures for air cooled systems.

By carefully reviewing the information within this manual and following the instructions, the risk of improper operation and/or component damage will be minimized.

It is important that periodic maintenance be performed to help assure trouble free operation. A maintenance schedule is provided at the end of this manual.

Should equipment failure occur, contact a qualified service organization with qualified, experienced HVAC technicians to properly diagnose and repair this equipment.

# Table of Contents

Model Number Description .....	5
General Information .....	6
Unit Description .....	6
System Input Devices & Functions .....	6
Sensors .....	6
Unit Inspection .....	6
Storage .....	7
Unit Clearances .....	7
Dimensional Data .....	8
Unit Weights .....	14
Rigging .....	14
Installation .....	15
Unit Foundation .....	15
General Unit Requirements .....	15
Main Unit Power .....	16
Factory-Mounted Unit Options .....	20
Unit Disconnect (FIYUDC) .....	20
Pre Start .....	21
Verifying Proper Air Flow (Units with Belt Drive Indoor Fan) .....	21
Electromechanical Controls Test Procedure .....	21
Start Up .....	22
Economizer Start-Up .....	22
Compressor Start-Up .....	22
Heating Start-Up .....	23
Final System Set Up .....	23
Maintenance .....	24
Fan Belt Adjustment—Belt Drive Units ..	24
Monthly Maintenance .....	25
Final Process .....	26
Troubleshooting .....	27
Failures .....	27
Resetting Cooling and Heating Lockouts .	27
Condensate Overflow Switch .....	27
Unit Economizer Control (ECA) .....	27
Wiring Diagrams .....	28
Warranty .....	29
Central Air Conditioner .....	29

# Model Number Description

E	A	C	1	8	0	A	3	E	G	A	0	0
1	2	3	4	5	6	7	8	9	10	11	12	13

## Digit 1 – Unit Type

E = Packaged Cooling, Electric Heat

## Digit 2 – Efficiency

A = ASHRAE 90.1 - 2010

## Digit 3 – Airflow Configuration

C = Convertible  
D = Downflow Only

## Digit 4, 5, 6 – Nominal Gross Cooling Capacity (MBh)

180 = 15 Tons  
210 = 17½ Tons  
240 = 20 Tons  
300 = 25 Tons

## Digit 7 – Major Design Sequence

A

## Digit 8 – Voltage Selection

K = 380/60/3

## Digit 9 – Unit Controls

E = Electromechanical

## Digit 10 – Heating Capacity

0 = No Heat  
G = 18 kW Electric Heat  
N = 36 kW Electric Heat  
P = 54 kW Electric Heat  
R = 72 kW Electric Heat

## Digit 11 – Minor Design Sequence

## Digit 12, 13 – Service Sequence

00 = None

## Digit 14 – Fresh Air Selection<sup>3</sup>

0 = No Fresh Air  
A = Manual Outside Air Damper 0-50%  
B = Motorized Outside Air Damper 0-50%  
C = Economizer, Dry Bulb 0-100% without Barometric Relief<sup>4</sup>  
D = Economizer, Dry Bulb 0-100% with Barometric Relief<sup>1,4</sup>  
E = Economizer, Reference Enthalpy 0-100% without Barometric Relief<sup>4</sup>  
F = Economizer, Reference Enthalpy 0-100% with Barometric Relief<sup>1,4</sup>  
G = Economizer, Comparative Enthalpy 0-100% without Barometric Relief<sup>4</sup>  
H = Economizer, Comparative Enthalpy 0-100% with Barometric Relief<sup>1,4</sup>

## Digit 15 – Supply Fan/Drive Type/Motor

0 = Standard Motor  
1 = Oversized Motor

## Digit 17 – Condenser Coil Protection

0 = Standard Coil  
4 = CompleteCoat™ Condenser Coil

## Digit 18 – Through The Base Provisions

0 = No Through The Base Provisions  
A = Through The Base Electric

## Digit 19 – Disconnect Switch

0 = No Disconnect  
1 = Unit Mounted Non-Fused Disconnect Switch<sup>2</sup>

## Digit 25 - System Monitoring Controls

0 = No Monitoring Controls  
A = Condensate Drain Pan Overflow Switch

## Model Number Notes

1. Some field set up required.
2. Must be ordered with Through-the-Base Electrical option.
3. All Factory Installed Options are Built-to-Order. Check order services for estimated production cycle.
4. Factory installed economizers only available in downflow configuration.

# General Information

## Unit Description

Before shipment, each unit is leak tested, dehydrated, charged with refrigerant and compressor oil, and run tested for proper control operation.

Direct-drive, vertical discharge condenser fans are provided with built-in thermal overload protection.

The stages of capacity control for these units are achieved by starting the Economizer Control Actuator (ECA).

### Economizer Control Actuator Electromechanical Control

The ECA monitors the mixed air temperature, return air temperature, minimum position setpoint (local or remote), power exhaust setpoint, CO<sub>2</sub> setpoint, CO<sub>2</sub>, and ambient dry bulb/ enthalpy sensor or comparative humidity (return air humidity against ambient humidity) sensors, if selected, to control dampers to an accuracy of  $\pm 5$  percent of stroke. The actuator is spring returned to the closed position any time that power is lost to the unit. It is capable of delivering up to 25 in-lb of torque and is powered by 24 Vac.

## System Input Devices & Functions

The unit must have a thermostat input in order to operate.

The descriptions of the following basic Input Devices used within the unit are to acquaint the operator with their function as they interface with the various features.

Refer to the unit's electrical schematic for the specific device connections. The following controls are available from the factory for field installation.

### Drain Pan Condensate Overflow Switch (Optional)

This input incorporates the Condensate Overflow Switch (COF) mounted on the drain pan. When the condensate level reaches the trip point, the COF relay energizes and opens the 24VAC control circuit, disabling the unit. A delay timer prevents the unit from starting for 3 minutes.

### Phase Monitor

The Phase Monitor is a three-phase line monitor module that protects against phase loss, phase reversal and phase unbalance. It is intended to protect compressors from reverse rotation. It has an operating input voltage range of 190–600 Vac, and LED indicators for ON and FAULT. There are no field adjustments and the module will automatically reset from a fault condition.

### Discharge Line Thermostat Control

The high pressure controls and discharge line thermostats are wired in series between the thermostat signal and the compressor contactors. If the high pressure control switch or the discharge line thermostat open, the 24VAC signal from the thermostat is interrupted and the compressor is disabled. There is no automatic lockout.

### Evaporator Frost Control (Optional)

This input incorporates the Frostat™ control (FOS) mounted in the indoor coil and can be activated by closing a field supplied contact installed in parallel with the FOS.

If this circuit is open before the compressor is started, the compressor will not be allowed to operate. Anytime this circuit is opened for 5 continuous seconds during compressor operation, the compressor for that circuit is immediately turned "Off". The compressor will not be allowed to restart for a minimum of 3 minutes should the FOS close.

## Sensors

### High Temperature Sensor (BAYFRST003\*)

This sensor connects to the Emergency Stop Input on the LTB and provides high limit "shutdown" of the unit. The sensor is used to detect high temperatures due to fire in the air conditioning or ventilation ducts. The sensor is designed to mount directly to the sheet metal duct. Each kit contains two sensors. The return air duct sensor (X1310004001) is set to open at 135°F.

The supply air duct sensor (X1310004002) is set to open at 240°F. The control can be reset after the temperature has been lowered approximately 25°F below the cutout setpoint.

### Thermostat (TCONT802AS32DA)

This thermostat is a multi-stage 3 heat/2 cool, auto-changeover digital display thermostat. It is a programmable thermostat, and a 7-day programmable stat with night setback shall be available. In addition, it is wall mounted.

### Thermostat (TCONT402AN32DA)

This thermostat is a multi-stage 3 heat/2 cool, auto-changeover digital display thermostat. It is a non-programmable, wall-mounted thermostat, and it can be used for economizer operation.

## Unit Inspection

As soon as the unit arrives at the job site:

- Verify that the nameplate data matches the data on the sales order and bill of lading (including electrical data).

- Verify that the power supply complies with the unit nameplate specifications.
- Visually inspect the exterior of the unit, including the roof, for signs of shipping damage.
- Visually inspect the internal components for shipping damage as soon as possible after delivery and before it is stored. Do not walk on the sheet metal base pans.
- If concealed damage is discovered, notify the carrier's terminal of damage immediately by phone and by mail. Concealed damage must be reported within 15 days.
  - Request an immediate joint inspection of the damage by the carrier and the consignee.
  - Do not remove damaged material from the receiving location.
  - Take photos of the damage, if possible. The owner must provide reasonable evidence that the damage did not occur after delivery.
- Notify the appropriate sales representative before installing or repairing a damaged unit.

- Skin Contact - Wash affected areas gently with soap and warm water after handling.

## Storage

Take precautions to prevent condensate from forming inside the unit's electrical compartments and motors if:

- The unit is stored before it is installed; or,
- The unit is set on the roof curb, and temporary heat is provided in the building. Isolate all side panel service entrances and base pan openings (e.g., conduit holes, S/A and R/ A openings, and flue openings) from the ambient air until the unit is ready for start-up.

**Note:** Do not use the unit's heater for temporary heat without first completing the start-up procedure detailed under "Start Up," p. 22.

The manufacturer will not assume any responsibility for equipment damage resulting from condensate accumulation on the unit's electrical and/or mechanical components.

## Unit Clearances

Figure 1, p. 8 illustrates the minimum operating and service clearances for either a single or multiple unit installation. These clearances are the minimum distances necessary to assure adequate serviceability, cataloged unit capacity, and peak operating efficiency.

Providing less than the recommended clearances may result in condenser coil starvation, "short-circuiting" of exhaust and economizer airflows, or recirculation of hot condenser air.

## Precautionary Measures

**⚠ WARNING**

**Fiberglass Wool!**

Product contains fiberglass wool. Disturbing the insulation in this product during installation, maintenance or repair will expose you to airborne particles of glass wool fibers and ceramic fibers known to the state of California to cause cancer through inhalation. You MUST wear all necessary Personal Protective Equipment (PPE) including gloves, eye protection, a NIOSH approved dust/mist respirator, long sleeves and pants when working with products containing fiberglass wool. Exposition to glass wool fibers without all necessary PPE equipment could result in cancer, respiratory, skin or eye irritation, which could result in death or serious injury.

- Avoid breathing fiberglass dust.
- Use a NIOSH approved dust/mist respirator.
- Avoid contact with the skin or eyes. Wear long-sleeved, loose-fitting clothing, gloves, and eye protection.
- Wash clothes separately from other clothing: rinse washer thoroughly.
- Operations such as sawing, blowing, tear-out, and spraying may generate fiber concentrations requiring additional respiratory protection. Use the appropriate NIOSH approved respiration in these situations.

## First Aid Measures

- Eye Contact - Flush eyes with water to remove dust. If symptoms persist, seek medical attention.

# Dimensional Data

**Figure 1. Typical installation clearance for single and multiple unit applications**

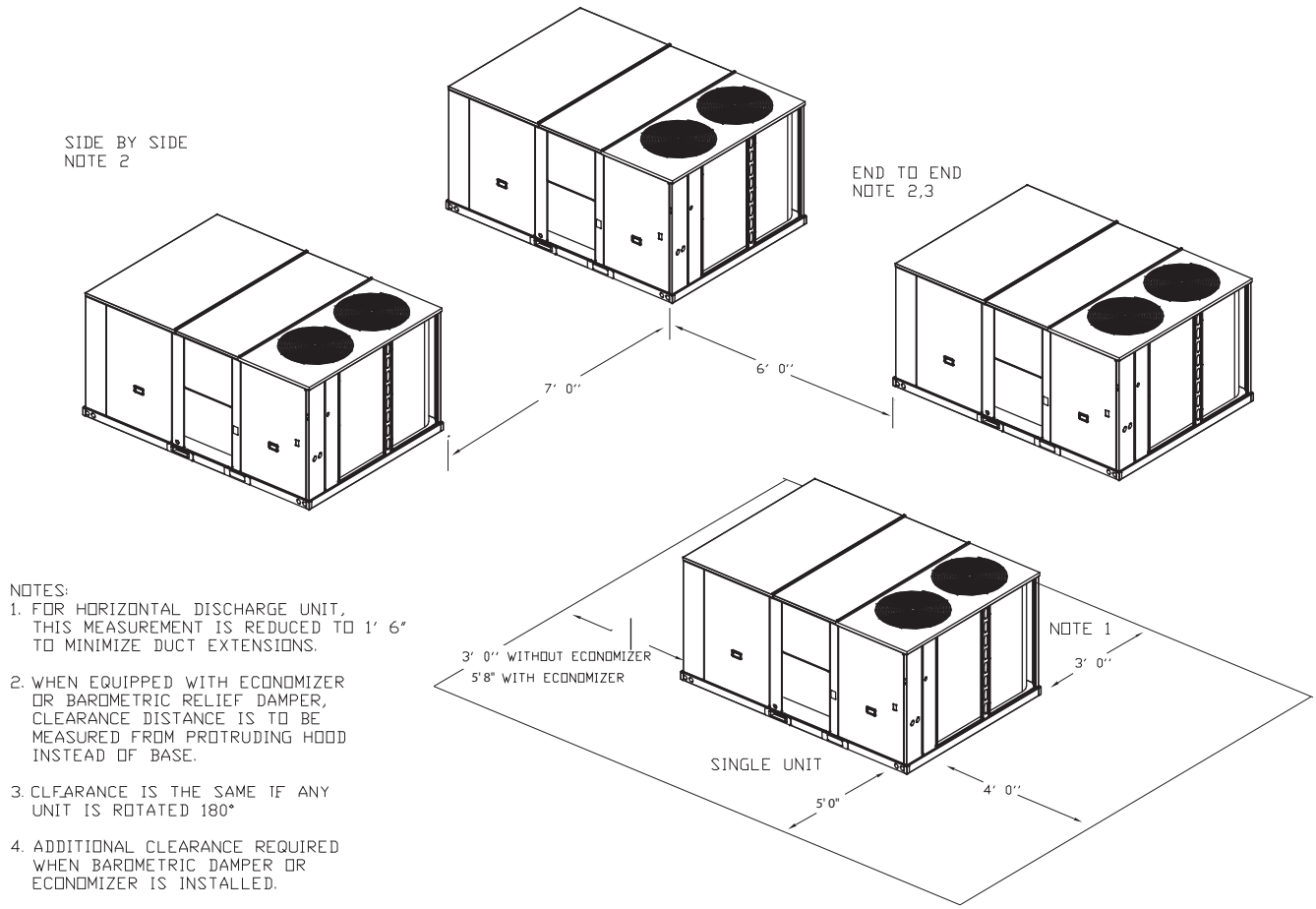



Figure 2. Cooling with optional electrical heat units — overview

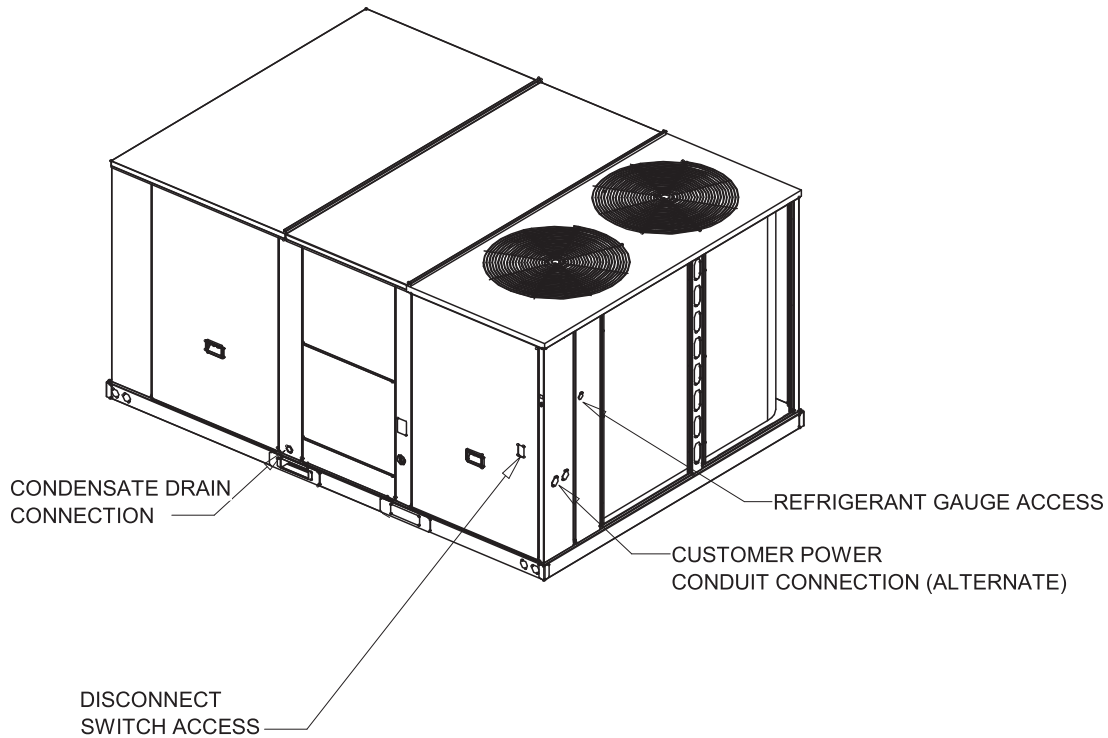
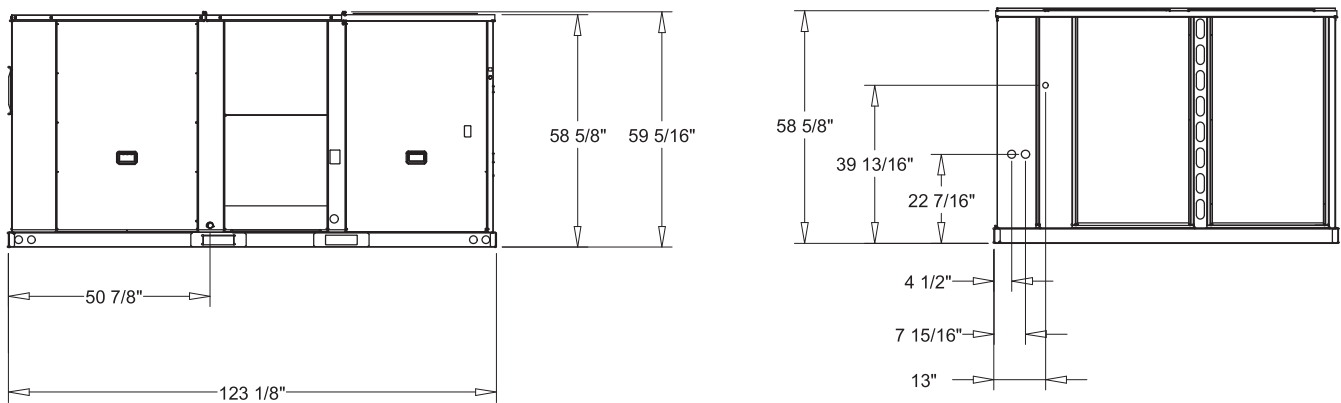

Figure 3. Cooling with optional electrical units — front & side views — 15–25 tons standard efficiency



NOTES:

1. THRU -THE -BASE ELECTRICAL IS NOT STANDARD ON ALL UNITS.
2. VERIFY WEIGHT, CONNECTION, AND ALL DIMENSION WITH INSTALLER DOCUMENTS BEFORE INSTALLATION

## Dimensional Data

**Figure 4. Cooling with optional electrical heat units — plan view — 15–25 tons standard efficiency**

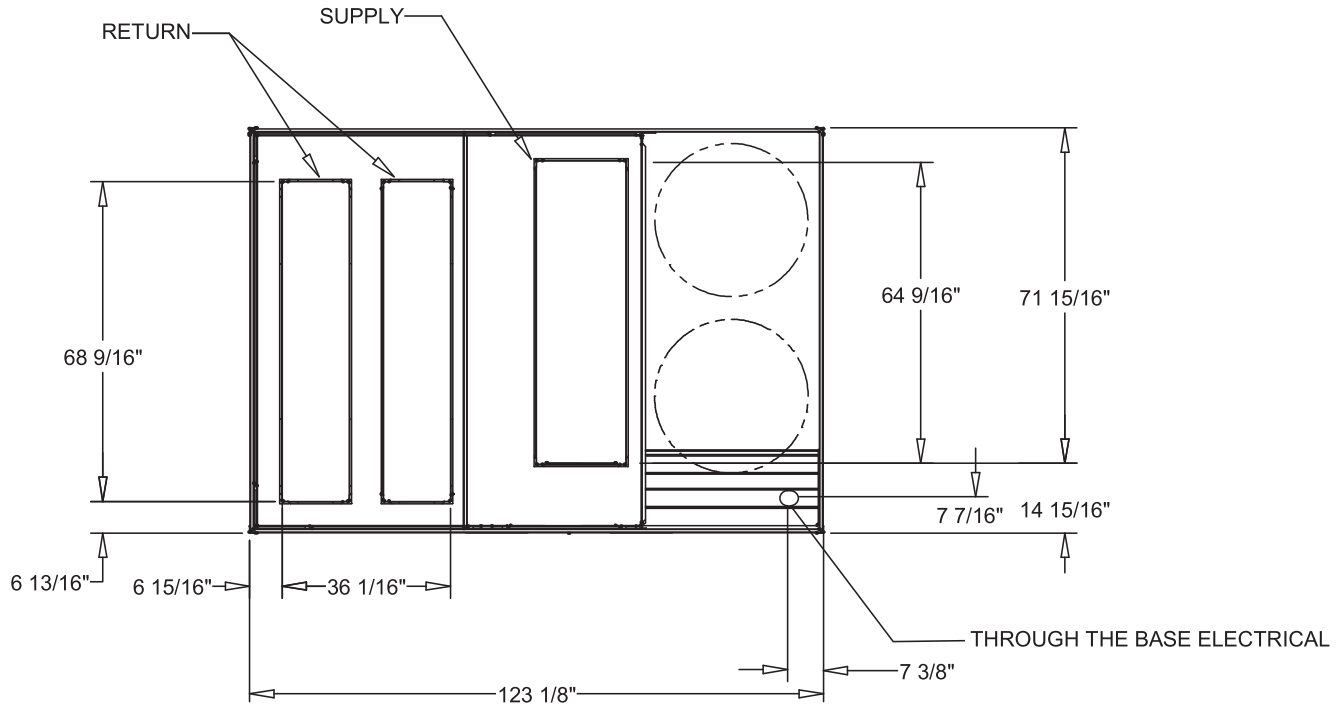

**NOTES:**

1. THRU -THE -BASE ELECTRICAL IS NOT STANDARD ON ALL UNITS.
2. VERIFY WEIGHT, CONNECTION, AND ALL DIMENSION WITH INSTALLER DOCUMENTS BEFORE INSTALLATION

**Figure 5. Foundation units — back view (horizontal configuration) — 15–25 tons standard efficiency**

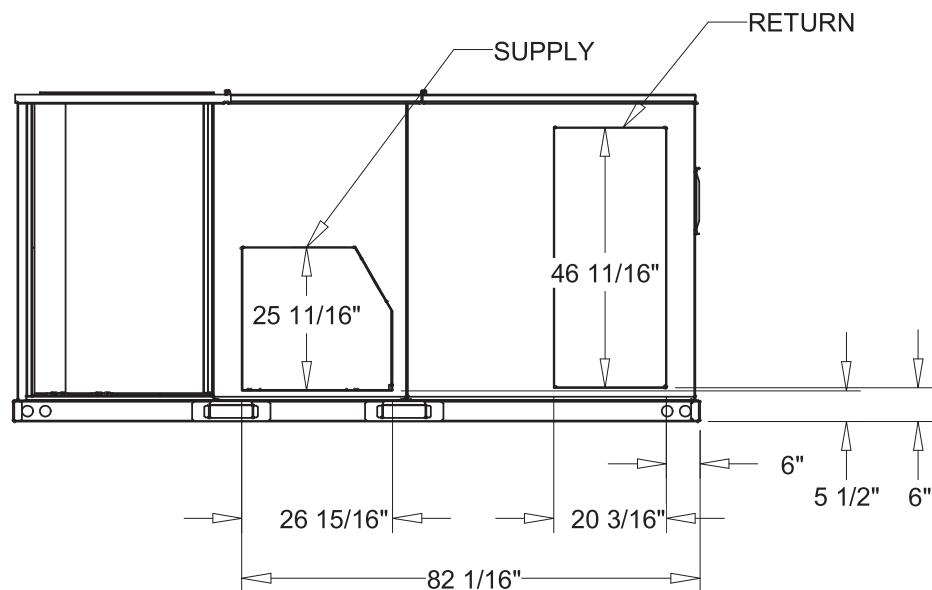

Figure 6. Roof curb – 15–25 tons standard efficiency

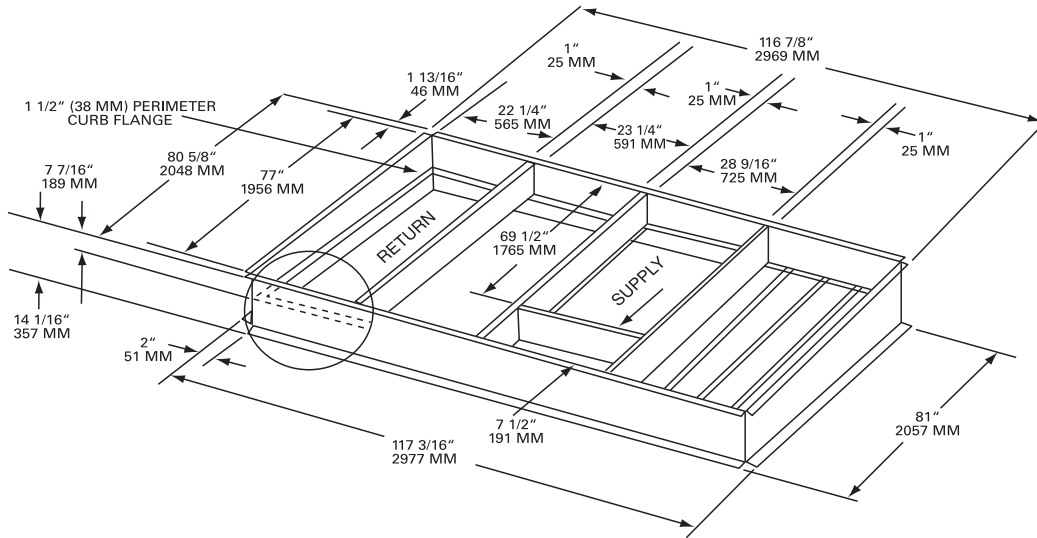
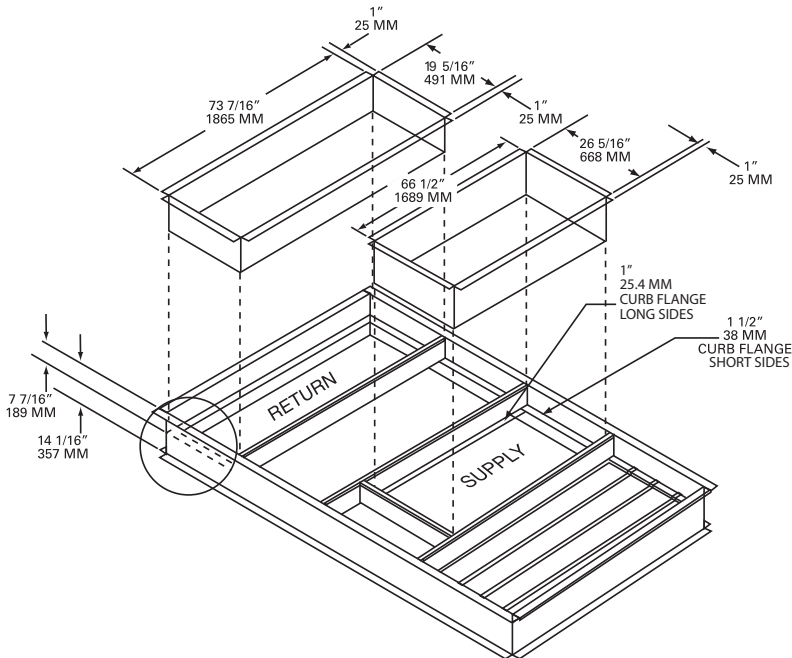

Figure 7. Downflow duct connections—field fabricated 15–25 tons standard efficiency



**Notes:**

- Duct flanges mount 7-7/16" down inside the curb on the 1-1/2" curb flanges.
- Roofcurb is intended for downflow use only.

## Dimensional Data

**Figure 8. Downflow unit clearance – 15–25 tons standard efficiency**

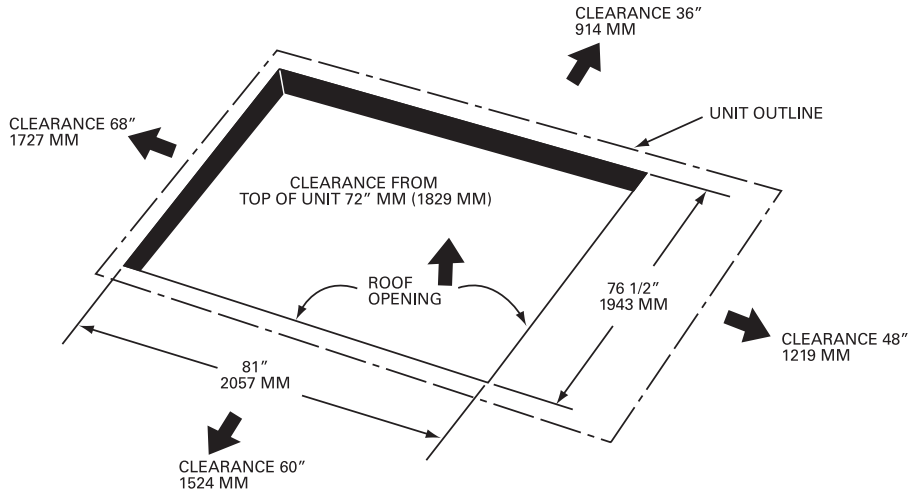

**Figure 9. Barometric relief and economizer – 15–25 tons standard efficiency**

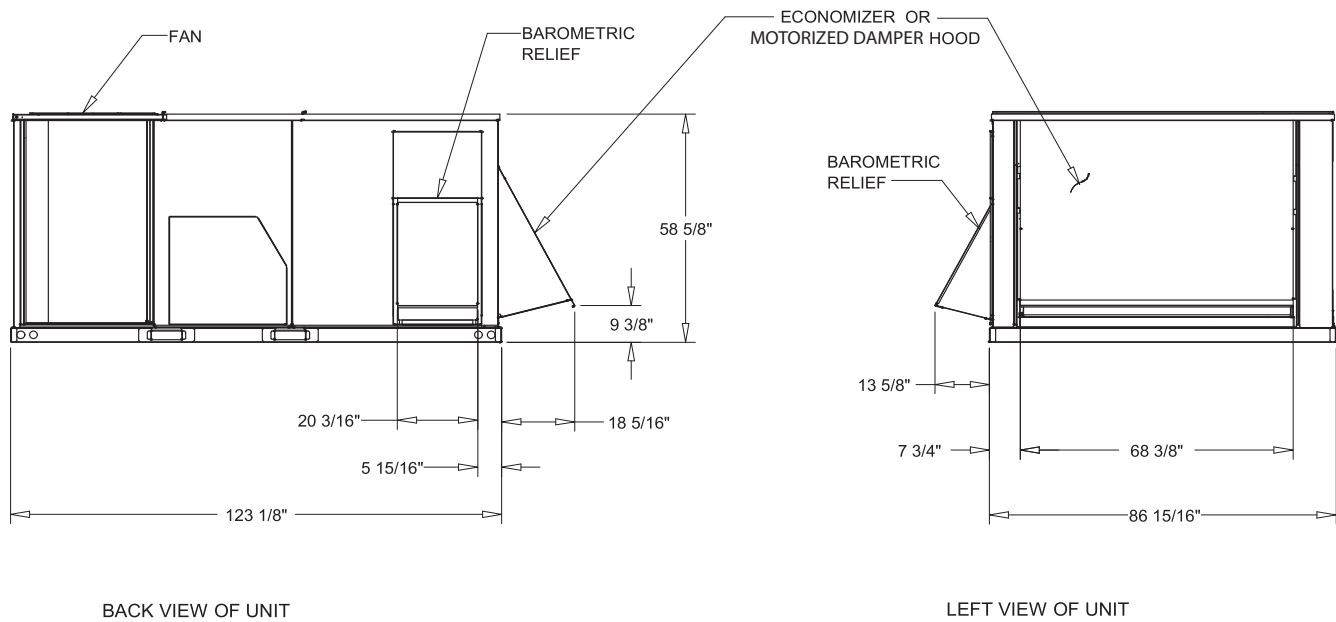

**NOTES:**

1. VERIFY WEIGHT, CONNECTION, AND ALL DIMENSION WITH INSTALLER DOCUMENTS BEFORE INSTALLATION
2. BAROMETRIC RELIEF IS FOR USE WITH A DOWNFLOW ECONOMIZER ONLY

Figure 10. Manual damper – 15–25 tons standard efficiency

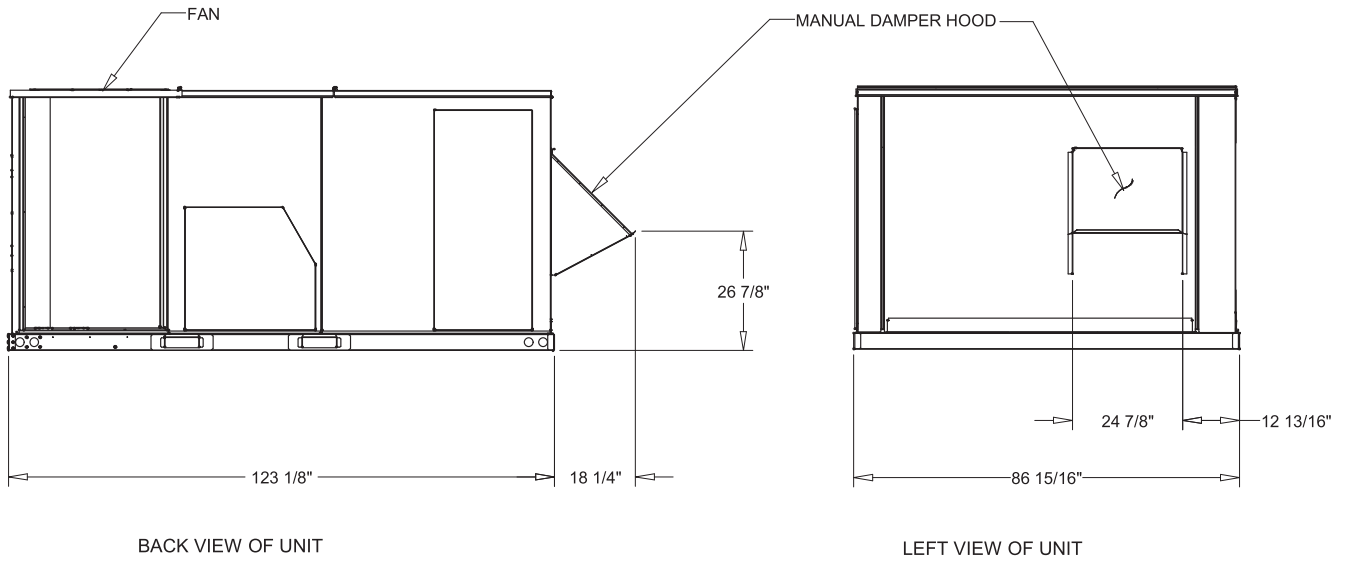

NOTE :  
1. VERIFY WEIGHT, CONNECTION, AND ALL DIMENSION  
WITH INSTALLER DOCUMENTS BEFORE INSTALLATION

# Unit Weights

**Table 1. Maximum unit & corner weights (lb) and center of gravity dimensions (in.)**

Tons	Unit Model No.	Weights (lb) <sup>(a), (b)</sup>		Corner Weights <sup>(c)</sup>				Center of Gravity (in.)	
		Shipping	Net	A	B	C	D	Length	Width
15	EAC180A	2020	1700	568	402	338	392	54"	37"
17½	EAC210A	2074	1755	578	418	358	400	55"	38"
20	EAC240A	2163	1844	632	438	357	416	54"	37"
25	EAC300A	2208	1888	664	457	345	422	53"	35"

(a) Weights are approximate. Horizontal and downflow unit and corner weights may vary slightly.

(b) Weights do not include additional factory or field installed options/accessories.

(c) Corner weights are given for information only. 15–25 ton models must be supported continuously by a curb or equivalent frame support.

**Figure 11. Corner weights**

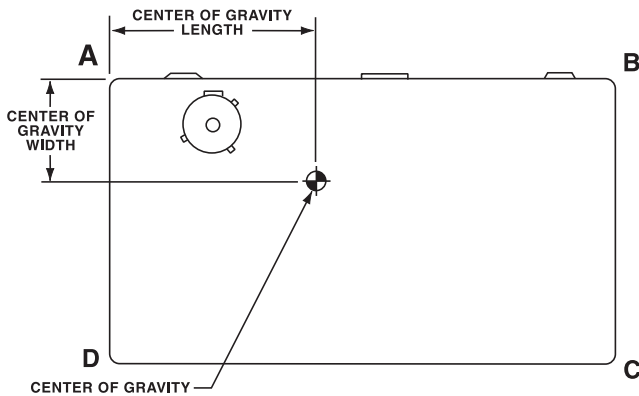

## Rigging

### ⚠ WARNING

#### Heavy Objects!

Ensure that all the lifting equipment used is properly rated for the weight of the unit being lifted. Each of the cables (chains or slings), hooks, and shackles used to lift the unit must be capable of supporting the entire weight of the unit. Lifting cables (chains or slings) may not be of the same length. Adjust as necessary for even unit lift. Other lifting arrangements could cause equipment or property damage. Failure to follow instructions above or properly lift unit could result in unit dropping and possibly crushing operator/technician which could result in death or serious injury.

### ⚠ WARNING

#### Improper Unit Lift!

Test lift unit approximately 24 inches to verify proper center of gravity lift point. To avoid dropping of unit, reposition lifting point if unit is not level. Failure to properly lift unit could result in unit dropping and possibly crushing operator/technician which could result in death or serious injury and possible equipment or property-only damage.

Refer to [Figure 12](#) and [Table 1](#) for typical unit operating weights rigging before proceeding.

1. Remove the shipping crate from around the unit. Do not remove the crating from the top of the unit.
2. Rig the unit as shown in [Figure 12](#), p. 14. Attach adequate strength lifting slings to all four lifting brackets in the unit base rail. Do not use cables, chains, or slings except as shown.
3. Install a lifting bar, as shown in [Figure 12](#), to protect the unit and to facilitate a uniform lift. The minimum distance between the lifting hook and the top of the unit should be 7 feet.
4. Test-lift the unit to ensure it is properly rigged and balanced, make any necessary rigging adjustments.
5. Lift the unit and position it into place.
6. Downflow units; align the base rail of the unit with the curb rail while lowering the unit onto the curb. Make sure that the gasket on the curb is not damaged while positioning the unit.

**Figure 12. Rigging and center of gravity data**

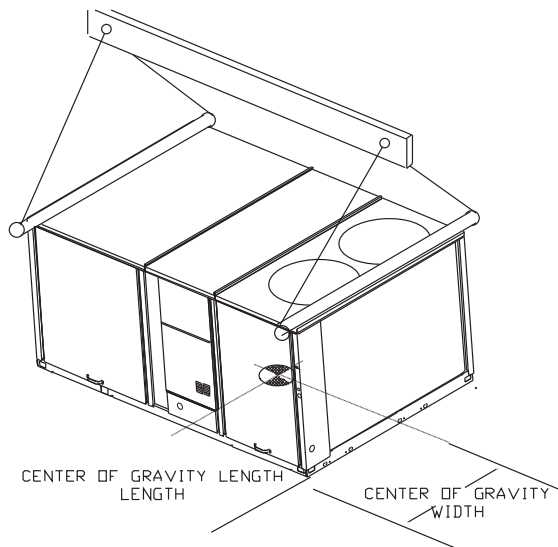

# Installation

## Unit Foundation

### ⚠ WARNING

#### Risk of Roof Collapsing!

Confirm with a structural engineer that the roof structure is strong enough to support the combined weight of the roof curb and the unit. Refer to “Unit Weights,” p. 14 for typical unit and curb weights. Failure to ensure proper structural roof support could cause the roof to collapse, which could result in death or serious injury and property damage.

### NOTICE:

#### Water Damage!

Non-factory penetrations through the base of this unit are not allowed. Any penetration in the base of the unit may affect the water tight integrity of the unit and lead to water leaks into the conditioned space. Failure to follow instructions could result in equipment and property damage.

## Horizontal Units

### Notes:

- For complete step by step instructions on how to install a Horizontal Conversion Kit, please refer to ACC-SVN159\*-EN.
- For units with optional Condensate Overflow Switch (COF), the switch will not work properly if unit is not level or slightly sloped toward switch.
- To assure proper condensate flow during operation the unit and the curb must be level.

If the unit is installed at ground level, elevate it above the snow line. Provide concrete footings at each support location with a “full perimeter” support structure or a slab foundation for support. Refer to Table 1, p. 14 for the unit’s operating and point loading weights when constructing a footing foundation.

If anchoring is required, anchor the unit to the slab using hold down bolts or isolators. Isolators should be installed to minimize the transmission of vibrations into the building.

For rooftop applications, if anchoring is required, anchor the unit to the roof with hold-down bolts or isolators.

Check with a roofing contractor for proper waterproofing procedures.

## Ductwork

Elbows with turning vanes or splitters are recommended to minimize air noise due to turbulence and to reduce static pressure.

When attaching the ductwork to the unit, provide a water-tight flexible connector at the unit to prevent operating sounds from transmitting through the ductwork.

All outdoor ductwork between the unit and the structure should be weather proofed after installation is completed.

**Note:** For sound consideration, cut only the holes in the roof deck for the ductwork penetrations. Do not cut out the entire roof deck within the curb perimeter.

If a Curb Accessory Kit is not used:

- a. The ductwork can be attached directly to the factory-provided flanges around the unit’s supply and return air openings. Be sure to use flexible duct connections at the unit.
- b. For “built-up” curbs supplied by others, gaskets must be installed around the curb perimeter flange and the supply and return air opening flanges.

## General Unit Requirements

### ⚠ WARNING

#### Proper Field Wiring and Grounding Required!

All field wiring MUST be performed by qualified personnel. Improperly installed and grounded field wiring poses FIRE and ELECTROCUTION hazards. To avoid these hazards, you MUST follow requirements for field wiring installation and grounding as described in NEC and your local/state electrical codes. Failure to follow code could result in death or serious injury.

The checklist listed below is a summary of the steps required to successfully install a commercial unit. This checklist is intended to acquaint the installing personnel with what is required in the installation process. It does not replace the detailed instructions called out in the applicable sections of this manual.

- Check the unit for shipping damage and material shortage; file a freight claim and notify appropriate sales representative.
- Verify correct model, options and voltage from nameplate.
- Verify that the installation location of the unit will provide the required clearance for proper operation.
- Assemble and install the roof curb (if applicable). Refer to the latest edition of the curb installers guide that ships with each curb kit.
- Fabricate and install ductwork; secure ductwork to curb.
- Rigging the unit.
- Set the unit onto the curb; check for levelness.

## Installation

---

- Ensure unit-to-curb seal is tight and without buckles or cracks.
- Install and connect a condensate drain line to the evaporator drain connection.

### Factory Installed Economizer

- Ensure the economizer has been pulled out into the operating position. Refer to the economizer installers guide for proper position and setup.
- Install all access panels.

### Main Electrical Power Requirements

- Verify that the power supply complies with the unit nameplate specifications.
- Inspect all control panel components; tighten any loose connections.
- Connect properly sized and protected power supply wiring to a field-supplied/ installed disconnect switch and to the main power terminal block (HTB1) in the unit control panel.
- Install proper grounding wires to an earth ground.

**Note:** All field-installed wiring must comply with NEC and applicable local codes.

### Electric Heat Requirements

- Verify that the power supply complies with the electric heater specifications on the unit and heater nameplate.
- Inspect the heater junction box and control panel; tighten any loose connections.
- Check electric heat circuits for continuity.
- Low Voltage Wiring (AC and DC) Requirements
- Install the zone thermostat, with or without switching subbase.
- Connect properly sized control wiring to the proper termination points between the zone thermostat and the unit control panel.

### Condensate Drain Configuration

An evaporator condensate drain connection is provided on each unit. Refer to “[Dimensional Data](#),” p. 8 for the appropriate drain location.

A condensate trap must be installed at the unit due to the drain connection being on the “negative pressure” side of the fan.

A condensate drain line must be connected to the P-Trap. Pitch the drain lines at least ½-inch for every 10 feet of horizontal run to assure proper condensate flow. Do not allow the horizontal run to sag causing a possible double-trap condition which could result in condensate backup due to “air lock”.

### Filter Installation

Each unit ships with 2-inch filters installed. The quantity of filters is determined by unit size. Access to the filters is obtained by removing the filter access panel.

Refer to the unit Service Facts (shipped with each unit) for filter requirements.

**Note:** Do not operate the unit without filters.

### Field Installed Power Wiring

An overall dimensional layout for the standard field installed wiring entrance into the unit is illustrated in “[Dimensional Data](#),” p. 8. To insure that the unit’s supply power wiring is properly sized and installed, follow the guidelines outlined below.

**Note:** All field installed wiring must conform to NEC guidelines as well as state and Local codes.

Verify that the power supply available is compatible with the unit’s nameplate ratings. The available supply power must be within 10 percent of the rated voltage stamped on the nameplate. Use only copper conductors to connect the power supply to the unit.

#### **NOTICE:**

#### **Use Copper Conductors Only!**

**Unit terminals are not designed to accept other types of conductors. Failure to use copper conductors could result in equipment damage.**

**Note:** If the unit is not equipped with an optional factory installed nonfused disconnect switch or circuit breaker, a field supplied disconnect switch must be installed at or near the unit in accordance with the National Electrical Code (NEC latest edition).

### Main Unit Power

#### **⚠ WARNING**

#### **Proper Field Wiring and Grounding Required!**

**All field wiring MUST be performed by qualified personnel. Improperly installed and grounded field wiring poses FIRE and ELECTROCUTION hazards. To avoid these hazards, you MUST follow requirements for field wiring installation and grounding as described in NEC and your local/state electrical codes. Failure to follow code could result in death or serious injury.**

### Standard Wiring

The electrical service must be protected from over current and short circuit conditions in accordance with NEC requirements.

Protection devices must be sized according to the electrical data on the nameplate.



- If the unit is not equipped with an optional factory installed nonfused disconnect switch, a field supplied disconnect switch must be installed at or near the unit in accordance with the National Electrical Code (NEC latest edition).
- Location of the applicable electrical service entrance is illustrated in "Dimensional Data," p. 8. Complete the unit's power wiring connections onto either; the main terminal block HTB1 inside the unit control panel, the factory mounted nonfused disconnect switch (UCD), or the electric heat terminal block. Refer to the customer connection diagram that shipped with the unit for specific termination points.
- Provide proper grounding for the unit in accordance with local and national codes.

### Optional TBUE Wiring (Through the Base Electrical Option)

- Location of the applicable electrical service is illustrated below. Refer to the customer connection diagram that is shipped with the unit for specific termination points. The termination points, depending on the customer option selected would be a factory mounted nonfused disconnect switch (UDC).
- Provide proper grounding for the unit in accordance with local and national codes.

Figure 13. Through the base electrical option

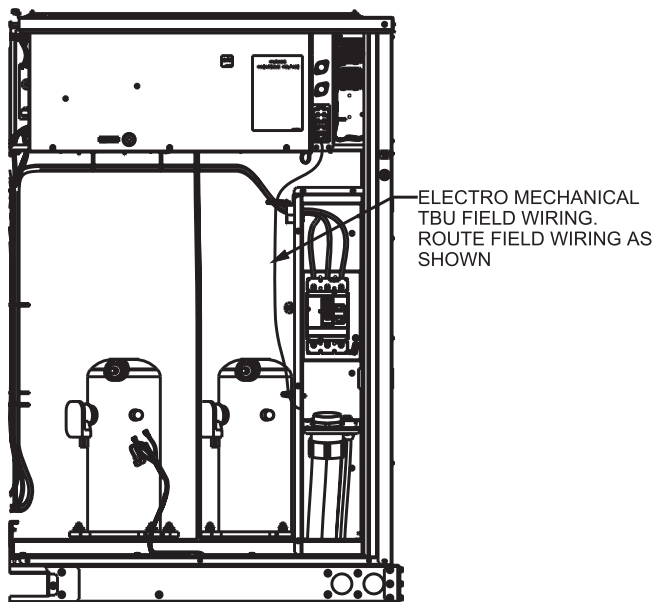

### Control Power Transformer

The 24-volt control power transformers are to be used only with the accessories called out in this manual. Transformers rated greater than 50 Vac are equipped with internal circuit breakers. If a circuit breaker trips, turn "Off" all power to the unit before attempting to reset it.

The transformer is located in the control panel. The circuit breaker is located on the left side of the transformer and can be reset by pressing in on the black reset button.

### Controls using 24 Vac

Before installing any connecting wiring, refer to "Dimensional Data," p. 8 for the electrical access locations provided on the unit and Table 2, p. 17 for AC conductor sizing guidelines.

**NOTICE:**

**Use Copper Conductors Only!**

**Unit terminals are not designed to accept other types of conductors. Failure to use copper conductors could result in equipment damage.**

1. Use copper conductors unless otherwise specified.
2. Ensure that the AC control wiring between the controls and the unit's termination point does not exceed three (3) ohms/conductor for the length of the run.

**Note:** Resistance in excess of 3 ohms per conductor could cause component failure due to insufficient AC voltage supply.

3. Be sure to check all loads and conductors for grounds, shorts, and mis-wiring.
4. Do not run the AC low voltage wiring in the same conduit with the high voltage power wiring.
5. Route low voltage wiring per illustrations on the next page.

Table 2. Electromechanical thermostat 24 Vac conductors

Distance from Unit to Control	Recommended Wire Size
000–460 feet	18 gauge
000–140 m	0.75 mm <sup>2</sup>
461–732 feet	16 gauge

## Installation

**Figure 14. Conventional thermostat field wiring diagram**

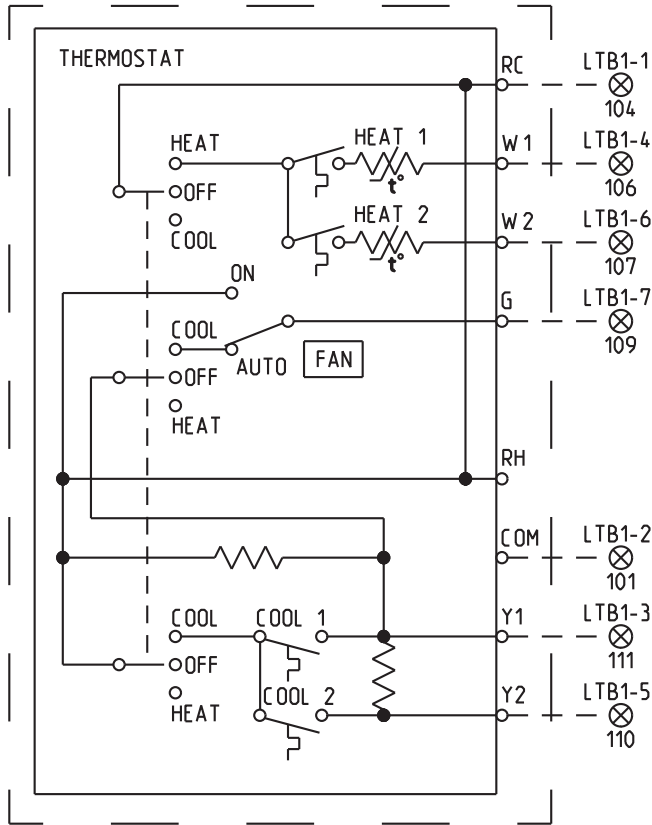

### Voltage Imbalance

Three phase electrical power to the unit must meet stringent requirements for the unit to operate properly. Measure each leg (phase-to-phase) of the power supply.

Each reading must fall within the utilization range stamped on the unit nameplate. If any of the readings do not fall within the proper tolerances, notify the power company to correct this situation before operating the unit.

Excessive three phase voltage imbalance between phases will cause motors to overheat and eventually fail.

The maximum allowable voltage imbalance is 2 percent. Measure and record the voltage between phases 1, 2, and 3 and calculate the amount of imbalance as follows:

% Voltage Imbalance =

$$\frac{100 \times AV - VD}{AV} \text{ where;}$$

AV (Average Voltage) =

$$\frac{\text{Volt 1} + \text{Volt 2} + \text{Volt 3}}{3}$$

- V1, V2, V3 = Line Voltage Readings
- VD = Line Voltage reading that deviates the farthest from the average voltage.

Example: If the voltage readings of the supply power measured 221, 230, and 227, the average volts would be:

$$\frac{221 + 230 + 227}{3} = 226 \text{ Avg.}$$

- VD (reading farthest from average) = 221
- The percentage of Imbalance equals:

$$\frac{100 \times 226 - 221}{226} = 2.2\%$$

The 2.2 percent imbalance in this example exceeds the maximum allowable imbalance of 2.0 percent. This much imbalance between phases can equal as much as a 20 percent current imbalance with a resulting increase in motor winding temperatures that will decrease motor life.

If the voltage imbalance is over 2 percent, notify the proper agencies to correct the voltage problem before operating this equipment.

### Electrical Phasing (Three Phase Motors)

The compressor motor(s) and the supply fan motor are internally connected for the proper rotation when the incoming power supply is phased as A, B, C.

Proper electrical supply phasing can be quickly determined and corrected before starting the unit by using an instrument such as an Associated Research Model 45 Phase Sequence Indicator and following the steps below:

#### **⚠ WARNING**

#### **Hazardous Voltage!**

**Disconnect all electric power, including remote disconnects before servicing. Follow proper lockout/tagout procedures to ensure the power can not be inadvertently energized. Failure to disconnect power before servicing could result in death or serious injury.**

- Turn the field supplied disconnect switch that provides power to the main power terminal block or to the "Line" side of the optional factory mounted disconnect switch to the "Off" position.
- Connect the phase sequence indicator leads to the terminal block or to the "Line" side of the optional factory mounted disconnect switch as follows;
  - Black (phase A) to L1
  - Red (phase B) to L2
  - Yellow (phase C) to L3
- Close the field supplied main power disconnect switch or circuit protector switch that provides the supply power to the unit.

**⚠ WARNING**

**Live Electrical Components!**

During installation, testing, servicing and troubleshooting of this product, it may be necessary to work with live electrical components. Have a qualified licensed electrician or other individual who has been properly trained in handling live electrical components perform these tasks. Failure to follow all electrical safety precautions when exposed to live electrical components could result in death or serious injury.

- Observe the ABC and CBA phase indicator lights on the face of the sequencer. The ABC indicator light will glow if the phase is ABC. If the CBA indicator light glows, open the disconnect switch or circuit protection switch and reverse any two power wires.
- Restore the main electrical power and recheck the phasing. If the phasing is correct, open the disconnect switch or circuit protection switch and remove the phase sequence indicator.

**Compressor Crankcase Heaters**

**NOTICE:**

**Compressors Failure!**

Unit must be powered and crankcase heaters energized at least 8 hours BEFORE compressors are started. This will protect the compressors from premature failure.

Each compressor can be equipped with a crankcase heater. The proper operation of the crankcase heater is important to maintain an elevated compressor oil temperature during the "Off" cycle to reduce oil foaming during compressor starts. Oil foaming occurs when refrigerant condenses in the compressor and mixes with the oil. In lower ambient conditions, refrigerant migration to the compressor could increase.

When the compressor starts, the sudden reduction in crankcase pressure causes the liquid refrigerant to boil rapidly causing the oil to foam. This condition could damage compressor bearings due to reduced lubrication and could cause compressor mechanical failures.

Before starting the unit in the "Cooling" mode, set the system switch to the "Off" position and turn the main power disconnect to the "On" position and allow the crankcase heater to operate a minimum of 8 hours.

Before closing the main power disconnect switch, insure that the "System" selection switch is in the "Off" position and the "Fan" selection switch is in the "Auto" position.

Close the main power disconnect switch and the unit mounted disconnect switch, if applicable.

**Checklist**

Use the following checklist in conjunction with the general checklist ("[General Unit Requirements](#)," p. 15) to ensure that the unit is properly installed and ready for operation.

**⚠ WARNING**

**Hazardous Voltage!**

Disconnect all electric power, including remote disconnects before servicing. Follow proper lockout/tagout procedures to ensure the power can not be inadvertently energized. Failure to disconnect power before servicing could result in death or serious injury.

- Check all electrical connections for tightness and "point of termination" accuracy.
- Verify that the condenser airflow is unobstructed.
- Verify that the condenser fan and indoor blower turn freely without rubbing and are properly tightened on the shafts.
- Check the supply fan belts for proper tension and the fan bearings for sufficient lubrication. If the belts require adjustment, or if the bearings need lubricating, refer to the maintenance section of this manual for instructions.
- Verify that a condensate trap is installed and the piping is properly sized and pitched.
- Verify that the correct size and number of filters are in place.
- Inspect the interior of the unit for tools and debris and install all panels in preparation for starting the unit.

# Factory-Mounted Unit Options

## Unit Disconnect (FIYUDC)

### ⚠ WARNING

#### Hazardous Voltage w/Capacitors!

Disconnect all electric power, including remote disconnects and discharge all motor start/run capacitors before servicing. Follow proper lockout/tagout procedures to ensure the power cannot be inadvertently energized. Verify with an appropriate voltmeter that all capacitors have discharged. Failure to disconnect power and discharge capacitors before servicing could result in death or serious injury.

For additional information regarding the safe discharge of capacitors, see PROD-SVB06A-EN

### ⚠ WARNING

#### Proper Field Wiring and Grounding Required!

All field wiring **MUST** be performed by qualified personnel. Improperly installed and grounded field wiring poses **FIRE** and **ELECTROCUTION** hazards. To avoid these hazards, you **MUST** follow requirements for field wiring installation and grounding as described in **NEC** and your local/state electrical codes. Failure to follow code could result in death or serious injury.

**Important:** All phases of this installation must comply with **NATIONAL, STATE, and LOCAL CODES**. In addition to local codes, the installation must comply with **National Electric Code - ANSI/NFPA NO. 70 LATEST REVISION**.

1. Field connections are made by first removing the compressor access panel on the front of the unit. Unscrew the assembly around the outside of the disconnect switch. This assembly is located in the condenser section of the unit.

For down flow configurations, the hole in the base section is for both high and low voltage power wiring on down flow units. Horizontal units will route through the holes in the front corner post where the disconnect enclosure is mounted. The hole is sized for 1 1/2" conduit.

2. If the conduit required for your application is larger, remove the termination plate and connect to the larger hole using field supplied reducing washers.
3. Route the power wires and ground conductor through conduit and into the bottom of the factory installed disconnect switch. Connect the power conductors to the lugs provided. Connect the ground wire to the unit ground lug.

**Note:** Wire size for the length of run should be determined using the circuit ampacity found on the unit nameplate and the N.E.C.

4. Route low voltage (class II), control wiring through hole in base of unit but not through high voltage conduit. Feed control wiring through bushing provided on side panel. Route wires through loose wire ties provided.
5. Tighten the wire ties. Secure the excess wire bundle under the wire ties in the outdoor section. Do not leave excess wire in the electrical enclosure. Use the unit wiring diagram to make the low voltage connections.

Figure 15. Field wiring route

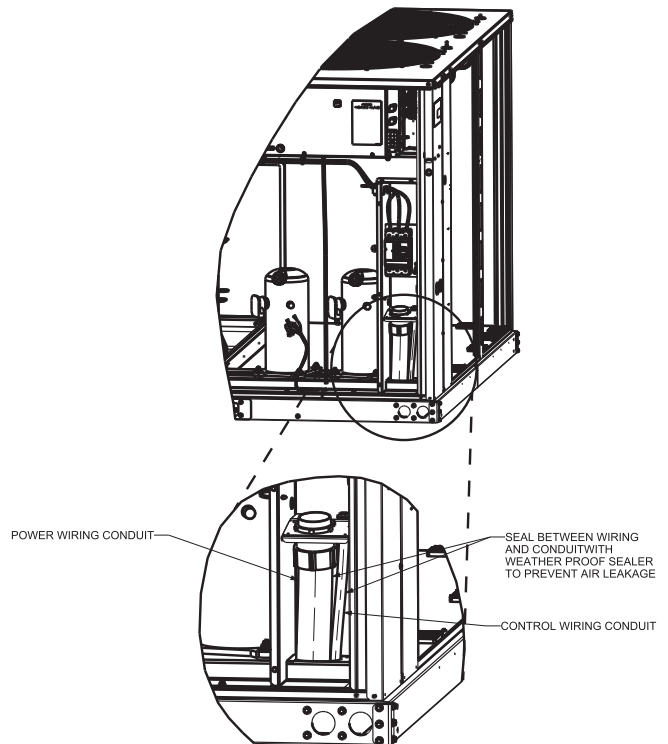

# Pre Start

## Verifying Proper Air Flow (Units with Belt Drive Indoor Fan)

Much of the systems performance and reliability is closely associated with, and dependent upon having the proper airflow supplied both to the space that is being conditioned and across the evaporator coil.

The indoor fan speed is changed by opening or closing the adjustable motor sheave.

Before starting the SERVICE TEST, set the minimum position setpoint for the economizer to 0% using the setpoint potentiometer located on the Economizer Control (ECA), if applicable.

## Electromechanical Controls Test Procedure

See unit schematic for correct wire numbers.

**Fan Test and Minimum Ventilation.** Connect red thermostat wire (R) to black thermostat wire (G).

**Economizer Cooling.** Connect a jumper wire across OAT on Economizer Control (ECA).

Connect red thermostat (R) wire to yellow thermostat wire (Y1).

**Cool 1.** Connect red thermostat wire (R) to yellow thermostat wire (Y1).

**Cool 2.** Connect red thermostat wire (R) to yellow thermostat wire (Y2).

**Heat 1.** Connect red thermostat wire (R) to brown thermostat wire (W1).

**Heat 2.** Connect red thermostat wire (R) to brown thermostat wire (W2).

# Start Up

## Economizer Start-Up

1. Set the minimum position setpoint for the economizer to the required percentage of minimum ventilation using the setpoint potentiometer located on the Economizer Control (ECA).

The economizer will drive to its minimum position setpoint, exhaust fans (if applicable) may start at random, and the supply fan will start when the SERVICE TEST is initiated.

The Exhaust Fan will start anytime the economizer damper position is equal to or greater than the exhaust fan setpoint.

2. Verify that the dampers stroked to the minimum position.
3. Verify that the dampers stroked to the full open position.
4. To stop the SERVICE TEST, turn the main power disconnect switch to the "Off" position or proceed to the next component start-up procedure. Remove electro mechanical test mode connections (if applicable).

## Compressor Start-Up

1. Attach a set of service gauges onto the suction and discharge gauge ports for each circuit. Refer to the refrigerant circuit illustration in the Service Facts.

Using the Service Test Guide, perform the proper test mode connections.

### Scroll Compressors

- a. Once each compressor has started, verify that the rotation is correct. If wired correctly the suction pressure should drop and the discharge pressure should rise. If a scroll compressor is rotating backwards, it will not pump and a loud rattling sound can be observed.
- b. If the electrical phasing is correct, before condemning a compressor, interchange any two leads (at the compressor Terminal block) to check the internal phasing. Refer to the following illustration for the compressor terminal/phase identification. Do not allow the compressor to operate backwards for more than 5 seconds. Operation for a period of time longer than this will result in compressor damage. Copeland (Alliance) will experience failure also. If the compressor runs backward for an extended period, the motor winding can overheat and cause the motor winding thermostat to open.

Figure 16. Compressor terminal box

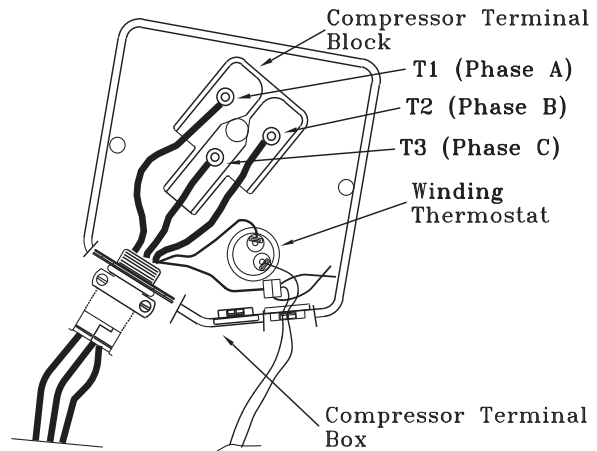

**Note:** The Copeland SSA scroll compressors for R-410A units use Trane OIL00094. The correct Oil for Trane CSHD is Trane OIL00079 or OIL00080. Compressor types are listed in [Table 3, p. 22](#). The appropriate oil charge is listed in [Table 4, p. 22](#).

Table 3. Compressor types

Tonnage	C1	C2
EA*180	SSA083	SSA076
EA*210	SSA091	SSA083
EA*240	CSHD142	SSA083
EA*300	CSHD155	SSA083

Table 4. POE Oil recharge amount (fl. oz.)

Model	C1 25mm	C2 25mm
EA*180	56	56
EA*210	56	56
EA*240	112	56
EA*300	112	56

2. After the compressor and condenser fan have started and operated for approximately 30 minutes, observe the operating pressures. Compare the operating pressures to the operating pressure curve in the Service Facts.
3. Check system subcooling. Follow the instruction listed on the subcooling charging curve in the Service Facts.
4. Repeat [Step 1](#) through [Step 3](#) for each refrigerant circuit.
5. To stop the SERVICE TEST, turn the main power disconnect switch to the "Off" position or proceed to the next component start-up procedure. Remove electro mechanical test mode connections (if applicable).

## Heating Start-Up

1. Clamp an amp meter around one of 1<sup>st</sup> stage heater power wires at the heater contactor.
2. Verify that the heater stage is operating properly.
3. Clamp an amp meter around one of 2<sup>nd</sup> stage heater power wires at the heater contactor (if applicable).
4. Verify that the heater stage is operating properly.
5. To stop the SERVICE TEST, turn the main power disconnect switch to the "Off" position or proceed to the next component start-up procedure. Remove electro mechanical test mode connections.

## Final System Set Up

After completing all of the pre-start and start-up procedures outlined in the previous sections (i.e., operating the unit in each of its modes through all available stages of cooling and heating), perform these final checks before leaving the unit:

- Program the Night Setback (NSB) panel (if applicable) for proper unoccupied operation. Refer to the programming instructions for the specific panel.
- Verify that the Remote panel "System" selection switch, "Fan" selection switch, and "Zone Temperature" settings for automatic operation are correct.
- Inspect the unit for misplaced tools, hardware, and debris.
- Verify that all exterior panels including the control panel doors and condenser grilles are secured in place.
- Close the main disconnect switch or circuit protector switch that provides the supply power to the unit's terminal block or the unit mounted disconnect switch.



# Maintenance

Make sure all personnel are standing clear of the unit before proceeding. The system components will start when the power is applied.

## Fan Belt Adjustment—Belt Drive Units

**⚠ WARNING**

**Rotating Components!**

The following procedure involves working with rotating components. Disconnect all electric power, including remote disconnects before servicing. Follow proper lockout/tagout procedures to ensure the power can not be inadvertently energized. Failure to disconnect power before servicing could result in rotating components cutting and slashing technician which could result in death or serious injury.

The fan belts must be inspected periodically to assure proper unit operation.

Replacement is necessary if the belts appear frayed or worn. Units with dual belts require a matched set of belts to ensure equal belt length.

When removing or installing the new belts, do not stretch them over the sheaves. Loosen the belts using the belt tension adjustment bolts on the motor mounting base.

Once the new belts are installed, using a Browning or Gates tension gauge (or equivalent) illustrated in [Figure 17](#); adjust the belt tension as follows;

1. To determine the appropriate belt deflection;
  - a. Measure the center-to-center shaft distance (in inches) between the fan and motor sheaves.
  - b. Divide the distance measured in [Step 1a](#) by 64; the resulting value represents the amount of belt deflection that corresponds to the proper belt tension.
2. Set the large O-ring on the belt tension gauge at the deflection value determined in [Step 1b](#).
3. Set the small O-ring at zero on the force scale of the gauge plunger.
4. Place the large end of the gauge at the center of the belt span; then depress the gauge plunger until the large O-ring is even with the top of the next belt or even with a straightedge placed across the fan and motor sheaves.
 

Refer to [Table 5, p. 24](#).
5. Remove the belt tension gauge. The small O-ring now indicates a number other than zero on the plunger's force scale. This number represents the force (in pounds) required to give the needed deflection.

6. Compare the "force" scale reading ([Step 5](#)) with the appropriate "force" value listed in [Table 5, p. 24](#). If the "force" reading is outside the range, readjust the belt tension.

**Note:** Actual belt deflection "force" must not exceed the maximum "force" value shown in [Table 5, p. 24](#).

7. Recheck the belt tension at least twice during the first 2 to 3 days of operation. Belt tension may decrease until the new belts are "run in".

**Figure 17. Belt tension gauge**

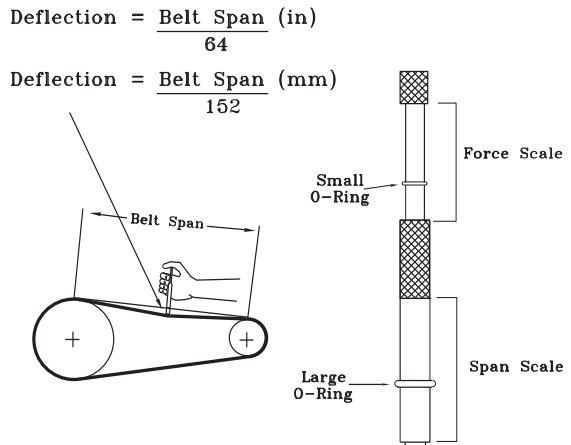

**Table 5. Belt tension measurement and deflection ranges**

Belts Cross Section	Small P.D Range (in.)	Deflection Force (lb)					
		Super Gripbelts (in.)		Gripnotch (in.)		Steel Cable Gripbelts (in.)	
		Min.	Max.	Min.	Max.	Min.	Max.
A	3.0–3.6	3	4 1/2	3 7/8	5 1/2	3 1/4	4
	3.8–4.8	3 1/2	5	4 1/2	6 1/4	3 3/4	4 3/4
	5.0–7.0	4	5 1/2	5	6 7/8	4 1/4	5 1/4
B	3.4–4.2	4	5 1/2	5 3/4	8	4 1/2	5 1/2
	4.4–5.6	5 1/8	7 1/8	6 1/2	9 1/8	5 3/4	7 1/4
	5.8–8.8	6 3/8	8 3/4	7 3/8	10 1/8	7	8 3/4

Belts Cross Section	Small P.D Range (mm)	Deflection Force (kg)					
		Super Gripbelts (mm)		Gripnotch (mm)		Steel Cable Gripbelts (mm)	
		Min.	Max.	Min.	Max.	Min.	Max.
A	13.3–16.0	13.3	20.0	17.2	24.5	14.5	17.8
	16.9–21.4	15.6	22.2	20.0	27.8	16.7	21.1
	22.0–31.1	17.8	24.5	22.2	30.6	18.9	23.4
B	15.1–18.7	17.8	24.5	25.6	35.6	20.0	24.5
	19.6–24.9	22.8	31.7	28.9	40.6	25.6	32.3
	25.8–39.1	28.4	38.9	32.8	45.0	31.1	38.9



## Monthly Maintenance

Before completing the following checks, turn the unit OFF and lock the main power disconnect switch open.

### **⚠ WARNING**

#### **Hazardous Voltage!**

**Disconnect all electric power, including remote disconnects before servicing. Follow proper lockout/tagout procedures to ensure the power can not be inadvertently energized. Failure to disconnect power before servicing could result in death or serious injury.**

### Filters

Inspect the return air filters. Clean or replace them if necessary. Refer to the unit Service Facts for filter information.

### Condensate Overflow Switch

During maintenance, the switch float (black ring) must be checked to ensure free movement up and down.

### Cooling Season

- Check the unit's drain pans and condensate piping to ensure that there are no blockages.
- Inspect the evaporator and condenser coils for dirt, bent fins, etc. If the coils appear dirty, clean them according to the instructions described in "[Condenser Coil Cleaning](#)," p. 25.
- Manually rotate the condenser fan(s) to ensure free movement and check motor bearings for wear. Verify that all of the fan mounting hardware is tight.
- Inspect the F/A-R/A damper hinges and pins to ensure that all moving parts are securely mounted. Keep the blades clean as necessary.
- Verify that all damper linkages move freely; lubricate with white grease, if necessary.
- Check supply fan motor bearings; repair or replace the motor as necessary.
- Check the fan shaft bearings for wear. Replace the bearings as necessary.
- Check the supply fan belt. If the belt is frayed or worn, replace it. Refer to "[Fan Belt Adjustment—Belt Drive Units](#)," p. 24 for belt replacement and adjustments.
- Verify that all wire terminal connections are tight.
- Remove any corrosion present on the exterior surfaces of the unit and repaint these areas.
- Generally inspect the unit for unusual conditions (e.g., loose access panels, leaking piping connections, etc.).
- Make sure that all retaining screws are reinstalled in the unit access panels once these checks are complete.

- With the unit running, check and record the: ambient temperature; compressor suction and discharge pressures (each circuit); superheat (each circuit); Record this data on an "operator's maintenance log" like the one shown in [Table 6, p. 26](#). If the operating pressures indicate a refrigerant shortage, measure the system superheat. For guidelines, refer to "[Compressor Start-Up](#)," p. 22.

**Note:** *Do NOT release refrigerant to the atmosphere! If adding or removing refrigerant is required, the service technician must comply with all federal, state and local laws.*

### Heating Season

- Inspect the unit's air filters. If necessary, clean or replace them.
- Check supply fan motor bearings; repair or replace the motor as necessary.
- Inspect both the main unit control panel and heat section control box for loose electrical components and terminal connections, as well as damaged wire insulation. Make any necessary repairs.
- Verify that the electric heat system operates properly.

### Condenser Coil Cleaning

Regular coil maintenance, including annual cleaning, enhances the unit's operating efficiency by minimizing: compressor head pressure and amperage draw; evaporator water carryover; fan brake horsepower, due to increase static pressure losses; airflow reduction.

At least once each year, or more often if the unit is located in a "dirty" environment, clean the condenser coils using the instructions outlined below. Be sure to follow these instructions as closely as possible to avoid damaging the coils.

### Microchannel (MCHE) Coils

#### **NOTICE:**

#### **Coil Damage!**

**DO NOT use any detergents with microchannel condenser coils. Use pressurized water or air ONLY, with pressure no greater than 600psi. Failure to do so could result in coil damage.**

*For additional information regarding the proper microchannel coil cleaning procedure, refer to RT-SVB83\*-EN.*

Due to the soft material and thin walls of the MCHE coils, the traditional field maintenance method recommended for Round Tube Plate Fin (RTPF) coils does not apply to microchannel coils.

Moreover, chemical cleaners are a risk factor to MCHE due to the material of the coil. The manufacturer does not

## Maintenance

recommend the use of chemical cleaners to clean microchannel coils. Using chemical cleaners could lead to warranty claims being further evaluated for validity and failure analysis.

The recommended cleaning method for microchannel condenser coils is pressurized water or air with a non-pinpoint nozzle and an ECU of at least 180 with pressure no greater than 600 psi. To minimize the risk of coil damage, approach the cleaning of the coil with the pressure washer aimed perpendicular to the face of the coil during cleaning. Optimum clearance between the sprayer nozzle and the microchannel coil is 1"–3".

## Final Process

For future reference, you may find it helpful to record the unit data requested below in the blanks provided.

(1) Complete Unit Model Number:

\_\_\_\_\_

(2) Unit Serial Number:

\_\_\_\_\_

(3) Wiring Diagram Numbers (from unit control panel)

– schematic(s)

– connection(s)

**Table 6. Sample maintenance log**

Date	Current Ambient Temp F/C	Refrigerant Circuit #1						Refrigerant Circuit #2					
		Compr. Oil Level	Suct. Press. Psig/kPa	Disch. Press. Psig/kPa	Liquid Press. Psig/kPa	Super-heat F/C	Sub-cool F/C	Compr. Oil Level	Suct. Press. Psig/kPa	Disch. Press. Psig/kPa	Liquid Press. Psig/kPa	Super-heat F/C	Sub-cool F/C
		- ok - low						- ok - low					
		- ok - low						- ok - low					
		- ok - low						- ok - low					
		- ok - low						- ok - low					
		- ok - low						- ok - low					
		- ok - low						- ok - low					
		- ok - low						- ok - low					
		- ok - low						- ok - low					
		- ok - low						- ok - low					
		- ok - low						- ok - low					
		- ok - low						- ok - low					

# Troubleshooting

## ⚠ WARNING

### Hazardous Service Procedures!

The maintenance and troubleshooting procedures recommended in this section of the manual could result in exposure to electrical, mechanical or other potential safety hazards. Always refer to the safety warnings provided throughout this manual concerning these procedures. Unless specified otherwise, disconnect all electrical power including remote disconnect and discharge all energy storing devices such as capacitors before servicing. Follow proper lockout/tagout procedures to ensure the power can not be inadvertently energized. When necessary to work with live electrical components, have a qualified licensed electrician or other individual who has been trained in handling live electrical components perform these tasks. Failure to follow all of the recommended safety warnings provided, could result in death or serious injury.

## Failures

### Cooling Failure

1. Cooling and heating set point (slide pot) on the thermostat has failed.
2. CC1 or CC2 24 VAC control circuit has opened. Check CC1 & CC2 coils, and any of the controls below that apply to the unit (HPC1, HPC2, LPC1, LPC2, DLT1, DLT2, Froststat™).

### Simultaneous Heat and Cool Failure

- Emergency Stop is activated.

## Resetting Cooling and Heating Lockouts

Cooling Failures and Heating Lockouts are reset in an identical manner.

“Method 1,” p. 27 explains resetting the system from the space; “Method 2,” p. 27 explains resetting the system at the unit.

**Note:** Before resetting Cooling Failures and Heating Lockouts check the Failure Status Diagnostics by the methods previously explained. Diagnostics will be lost when the power to the unit is disconnected.

### Method 1

To reset the system from the space, turn the “Mode” selection switch at the thermostat to the “Off” position. After approximately 30 seconds, turn the “Mode” selection switch to the desired mode, i.e. Heat, Cool or Auto.

### Method 2

To reset the system at the unit, cycle the unit power by turning the disconnect switch “Off” and then “On”.

## Condensate Overflow Switch

When the condensate overflow switch is closed, a drain pan overflow condition is indicated and it will shut unit operations down.

## Unit Economizer Control (ECA)

Verify Economizer Status by Economizer Actuator (ECA) LED indicator:

- OFF: No Power or Failure
- ON: Normal, OK to Economize
- Slow Flash: Normal, Not OK to Economize
- Fast Flash - 1/4 Second On / 2 Seconds Off:
  - Error Code: Communications Failure
- Pulse Flash: 1/30 Second On / 1/4 Second Off: (2 Seconds between pulse sequences)

### Error Code:

- 1 Flash: Actuator Fault
- 2 Flashes: CO<sub>2</sub> Sensor
- 3 Flashes: RA Humidity Sensor
- 4 Flashes: RA Temp Sensor
- 6 Flashes: OA Humidity Sensor
- 7 Flashes: OA Temp Sensor
- 8 Flashes: MA Temp Sensor
- 9 Flashes: On-board Setpoint Failure

# Wiring Diagrams

**Note:** Wiring diagrams can be accessed via e-Library by entering the diagram number in the literature order number search field or by contacting technical support.

**Table 7. Wiring diagrams**

Type of Airflow	Schematic Type	Voltage	Diagram Number	Description
Constant Volume	Power	208-230/ 380	2313-2202	EAC180-300, EAD180-300, 60Hz, Cooling only / Electric Heat
	Control	208-230/ 380	2313-2207	EAC180-300, EAD180-300, 60Hz, Cooling only / Electric Heat
	Raceway Connection	208-230/ 380	2313-2239	EAC180-300, EAD180-300, 60Hz, Cooling only / Electric Heat
	Control Box Connection	208-230/ 380	2313-2230	EAC180-300, EAD180-300, 60Hz, Cooling only / Electric Heat

# Warranty

## Central Air Conditioner

### EAC, EAD (Parts Only)

#### Models Less than 20 Tons for Commercial Use\*

This warranty is extended by Trane, to the original purchaser and to any succeeding owner of the real property to which the Air Conditioner is originally affixed, and applies to products purchased and retained for use within the U.S.A. and Canada. There is no warranty against corrosion, erosion or deterioration.

If any part of your Air Conditioner fails because of a manufacturing defect within one year from the date of the original purchase, Warrantor will furnish without charge the required replacement part.

In addition, if the sealed motor-compressor fails because of a manufacturing defect within the second through fifth year from the date of original purchase, Warrantor will furnish without charge the required replacement compressor.

Warrantor's obligations and liabilities under this warranty are limited to furnishing F.O.B. Warrantor factory or warehouse replacement parts for Warrantor's products covered under this warranty.

Warrantor shall not be obligated to pay for the cost of lost refrigerant.

No liability shall attach to Warrantor until products have been paid for and then liability shall be limited solely to the purchase price of the equipment under warranty shown to be defective.

THE WARRANTY AND LIABILITY SET FORTH HEREIN ARE IN LIEU OF ALL OTHER WARRANTIES AND LIABILITIES, WHETHER IN CONTRACT OR IN NEGLIGENCE, EXPRESS OR IMPLIED, IN LAW OR IN FACT, INCLUDING BUT NOT SPECIFICALLY LIMITED TO IMPLIED WARRANTIES OF MERCHANTABILITY AND FITNESS FOR PARTICULAR USE, AND IN NO EVENT SHALL WARRANTOR BE LIABLE FOR ANY INCIDENTAL OR CONSEQUENTIAL DAMAGES.

Some states do not allow limitations on how long an implied warranty lasts or do not allow the exclusion or limitation of incidental or consequential damages, so the above limitation or exclusion may not apply to you. This warranty gives you specific legal rights, and you may also have other rights which vary from state to state.

Trane  
2701 Wilma Rudolph Blvd.  
Clarksville, TN 37040-1008  
Attention: Manager, Product Service  
GW-602-4800

\* This warranty is for commercial usage of said equipment and not applicable when the equipment is used for a residential application. Commercial use is any application

where the end purchaser uses the product for other than personal, family or household purposes.

#### Models 20 Tons and Greater for Commercial Use\*

The Company warrants for a period of 12 months from initial start-up or 18 months from date of shipment, whichever is less, that the Company products covered by this order (1) are free from defects in material and workmanship and (2) have the capacities and ratings set forth in the Company's catalogs and bulletins, provided that no warranty is made against corrosion, erosion or deterioration.

The Company's obligations and liabilities under this warranty are limited to furnishing f.o.b. factory or warehouse at Company designated shipping point, freight allowed to Buyer's city (or port of export for shipment outside the conterminous United States) replacement equipment (or at the option of the Company parts therefore) for all Company products not conforming to this warranty and which have been returned to the manufacturer.

The Company shall not be obligated to pay for the cost of lost refrigerant.

No liability whatsoever shall attach to the Company until said products have been paid for and then said liability shall be limited to the purchase price of the equipment shown to be defective.

The Company makes certain further warranty protection available on an optional extra-cost basis. Any further warranty must be in writing, signed by an officer of the Company.

The warranty and liability set forth herein are in lieu of all other warranties and liabilities, whether in contract or in negligence, express or implied, in law or in fact, including implied warranties of merchantability and fitness for particular use.

In no event shall the Company be liable for any incidental or consequential damages.

Trane  
2701 Wilma Rudolph Blvd.  
Clarksville, TN 37040-1008  
Attention: Manager, Product Service





The manufacturer optimizes the performance of homes and buildings around the world. A business of Ingersoll Rand, the leader in creating and sustaining safe, comfortable and energy efficient environments, the manufacturer offers a broad portfolio of advanced controls and HVAC systems, comprehensive building services, and parts. For more information, visit [www.IRCO.com](http://www.IRCO.com).

The manufacturer has a policy of continuous product and product data improvement and reserves the right to change design and specifications without notice.