

## Product Data Sheet

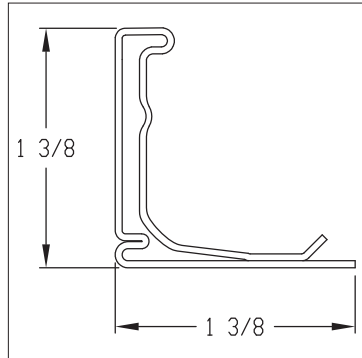
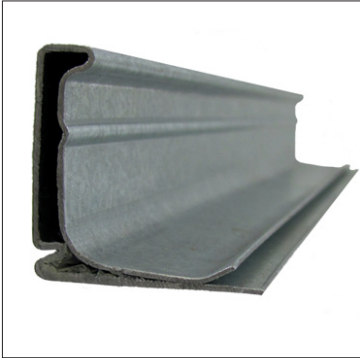

### Features

MADE IN USA with USA Steel  
 Union Made Yellow Label  
 Butyl in pocket for an energy efficient seal.  
 Sealing Materials meet NFPA 90A & B Class 1 requirements.

### Optional Construction

Stainless Steel 304  
 Stainless Steel 316  
 Aluminum  
 PCD  
 Galvanneal (Paint Grip)  
 Agion (Antimicrobial Coating)

### Description

The Elgen Flange is designed with two purposes in mind. The first is to provide external duct reinforcement, and the second is to provide a joining system between two similar size joints of duct.

Please refer to Elgen's 4-Corner Connection System document for fabrication, and assembly instructions.

### Standard Construction

Roll formed domestic galvanized steel that comes with a butyl sealant inside of the pocket to ensure an energy efficient seal.

Product comes standard in 10 and 20 foot lengths.

Duct Wall Size (in)	Pressure (in WG)	
	0-4	6-10
0-24	1 Screw each corner and center	1 Screw each corner and center
25-48	1 Screw each corner, plus 1 at center	2 Screws each corner, plus 1 screw every 12"
49 & over	1 Screw each corner, plus 1 every 12"	2 Screws each corner, plus 1 screw every 8"

### Technical Information

The Elgen Flange is tested in accordance with SMACNA testing procedures.

No external sealant was employed and the test results reveal: The Elgen Flange System is comparable to the SMACNA Class "J" transverse joint.

The Elgen Flange in stainless steel exhibits the same performance as galvanized.

The Elgen Flange in Aluminum is comparable to a SMACNA H connection.

Do not notch the corners when fabricating duct work for the Elgen Flange System.

### Packaging

Bundled in 10 and 20 foot lengths protected on 4 sides with corner board. Every bundle is banded using spring steel securing it to wooden blocks.

Length (ft)	Bundle Qty (ft)	Weight (lbs)
10	750	530
20	1,500	1060

### Guarantee

All Elgen products are guaranteed by Elgen Manufacturing against defective material.

### Elgen Manufacturing

10 Railroad Ave, Closter NJ 07624  
 Tel: 800.503.9805 :: Fax: 201.964.9030  
 info@elgenmfg.com :: www.elgenmfg.com