

ULTRA PRO™ SERIES FANS MODELS RB80, RB110

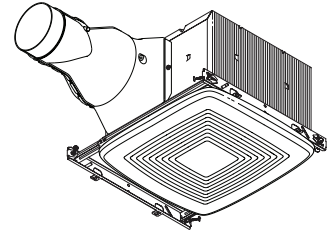

Quick Installation and Quiet Operation

FEATURES

UltraQuick™ Installation Technology

- Unique telescoping mounting frame fits through retrofit drywall opening to allow easy installation from the room side. No attic access needed!
- Captive mounting frame screws allow for easy new construction installation
- Mounting frame positioning tabs provide easy vertical positioning for new construction
- Works with any type of joist or truss system
- Duct connector and electrical knockout plate mount to outside or inside of housing, providing flexibility for new construction and retrofit applications
- Easy to insert and remove snap-in housing and blower

QStream™ Sound Technology

- Airflow-smoothing baffles reduce turbulence

QFlow™ Damper Technology

- When fan is on, damper position in the airstream is minimized to reduce static pressure and noise
- When fan is off, damper provides a tight seal to prevent back drafts

Blower

- Plug-in, permanently lubricated motor, engineered for continuous use

Housing

- Height allows for installation in 2" x 8" (nominal) construction

Grille

- Polymeric construction, innovative design

U.L. Listed for use over bathtubs and showers when connected to a GFCI-protected branch circuit (ceiling mount only)

Use an ON/OFF switch, timer, or speed control to operate this ventilator. Use of speed control other than the Broan 78V and 78W may cause a motor humming noise.

3 Year Warranty

Broan-NuTone LLC Hartford, Wisconsin www.broan.com 800-558-1711

DIMENSIONS (Inches)

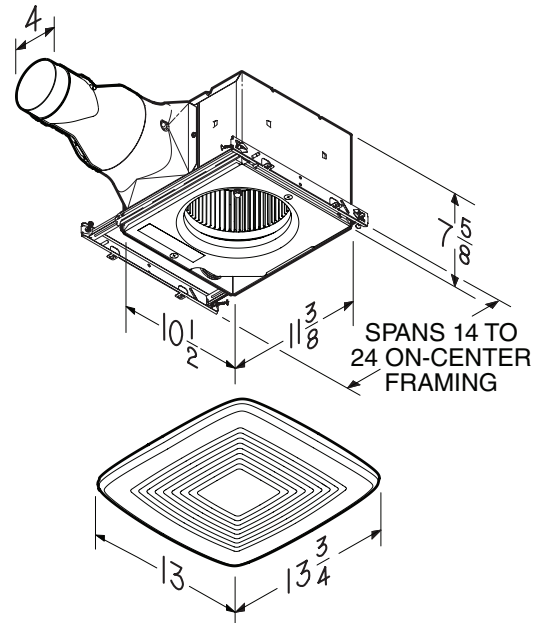

REFERENCE	QTY.	REMARKS	Project
			Location
			Architect
			Engineer
			Contractor
			Submitted by Date



PERFORMANCE SPECIFICATIONS ULTRA PRO™ SERIES FANS

HVI PERFORMANCE

Model	0.1 Ps - Static Pressure (inH2O)				0.25 Ps
	Airflow (CFM)	Sound (Sones)	Power (Watts)	Efficacy (CFM/Watt)	Airflow (CFM)
RB80	80	< 0.3	27.4	2.9	60
RB110	110	0.6	29.8	3.6	91



HVI-2100 CERTIFIED RATINGS comply with new testing technologies and procedures prescribed by the Home Ventilating Institute, for off-the-shelf products, as they are available to consumers. Product performance is rated at 0.1 in. static pressure, based on tests conducted in a state-of-the-art test laboratory. Sones are a measure of humanly-perceived loudness, based on laboratory measurements.

ELECTRICAL & WEIGHT

Model	Volts	Hz	Amps	Shipping Weight (lbs.)
RB80	120	60	0.3	12.0
RB110	120	60	0.3	12.0



Model RB80

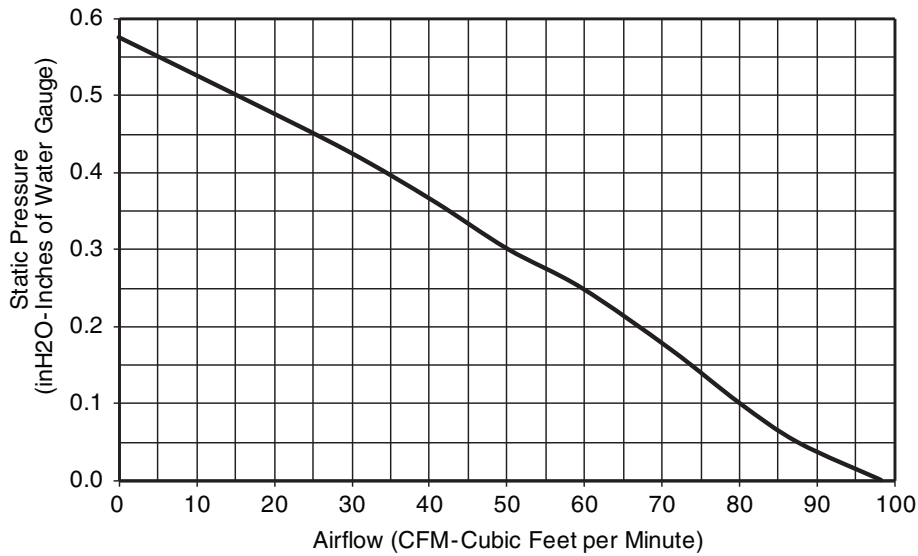

Model RB110

