

McDaniel Metals

281-987-8400 • 281-987-9494 (fax)
1318 Buschong, Houston, TX 77039
www.mcdanielmetals.com

DHZECNJPGCHL

HORIZONTAL JADE ECONOMIZER FOR
DAIKIN DP**G/DM**, DP**C/H**M
AND GOODMAN GPG-APG****M, GPG/
H-APG/H****M LARGE CHASSIS UNITS

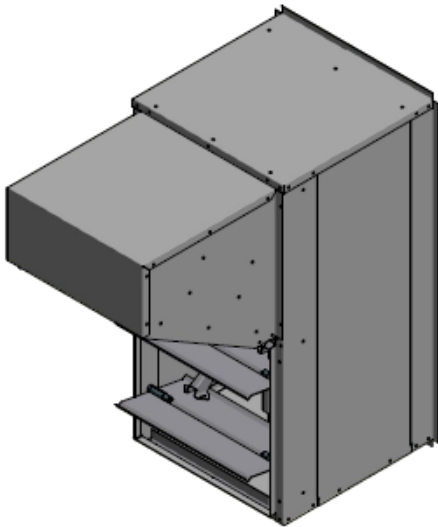

ECONOMIZER 101

Economizers are designed to provide “free” air conditioning when outside conditions are appropriate. When the outside air is cool and dry enough, the economizer automatically opens to introduce the cool air to the interior space, thereby eliminating the need to run the air conditioning compressor.

If the outside air becomes too warm or humid, the economizer automatically closes the fresh air damper and the compressor engages to begin cooling the space mechanically.

If a two stage thermostat is used it is possible to use a combination of economizer and mechanical cooling to condition the space.

The economizer can also be set to allow a minimum amount of fresh air to enter the space when the equipment’s indoor blower is operating.

Economizers are valuable tools to enhance indoor air quality, save energy and prolong the life of the air conditioning equipment.

SEQUENCE OF OPERATION

This sequence assumes employment of a single enthalpy economizer using a two stage thermostat.

1. A call for cooling comes from room thermostat.
2. The enthalpy sensor determines if the atmospheric conditions are conducive for using outside air for cooling. If YES, go to step 3. If NO, or if outdoor air temperature rises above enthalpy set point, go to step 4.
3. The outside air dampers open and modulate to maintain a mixed air temperature (outside air + indoor air) of 53 degrees F. If the outdoor air is insufficient to satisfy the thermostat alone and a second stage of cooling is required, the compressor starts and works in conjunction with the economizer

to cool the space. In a system with two compressors, if the thermostat is still not satisfied by the economizer and stage 1 compressor, the Jade control will energize the second compressor. (Go to step 5.)

4. Outdoor air dampers open to minimum position and the compressor engages to provide mechanical cooling.
5. When the thermostat is satisfied the outside air dampers return to a minimum position.

INSTALLATION

1. Open carton and inspect contents for shortages and damage.
 2. Disconnect power to the package unit.
 3. On the M series unit, remove the large blower (GPG/DPG) or evaporator (GPC/HM-DPC/HM) panel.
 4. Attach the damper section to the side of the unit over the horizontal return opening. (Figure 2)
 5. Connect the return duct to the economizer. See the chart below for the return opening size. (Figure 1)
 6. Remove the jumper from the economizer plug in the unit.
 7. Connect the jumper harness to the economizer and plug the economizer into the unit female moxlex plug.
- NOTE:** Some single phase units do not come with a plug for the economizer. The male plug from the economizer may be removed and the unit hard wired per the wiring diagram included.
8. Feed the red power wire from the jumper harness to the control section of the unit and connect it R on the terminal strip.
 9. Feed the pink mixed air sensor wire into the blower section of the unit and secure the mixed air sensor to the side of the blower toward the outer edge of the housing. (Figure 3)
 10. Connect the pink wires to the mixed air sensor and the Jade economizer control. (Figure 4)
 11. Restore power to the unit.
 12. Determine the minimum position setting using the minimum set point equation on page two.
 13. Seal connection between the fresh air hood and plenum until water tight.
 14. Install Goodman IRKT-01 Isolation Relay Kit for heat pumps per the instructions included with the IRKT-01.

This product is warranted to be free from defects due to workmanship or materials, under normal use, for a period of sixty (60) months from date of installation.

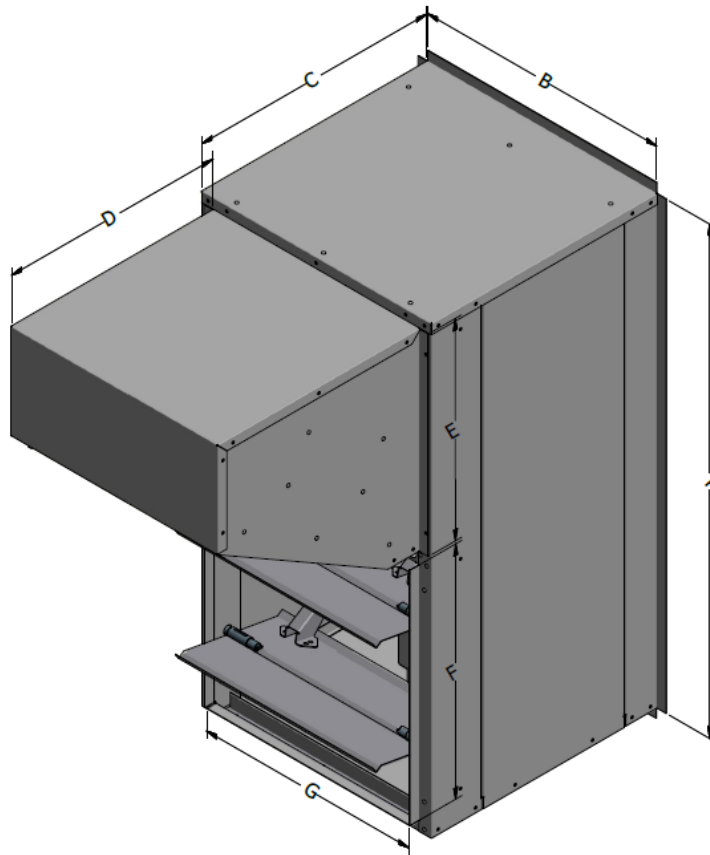

Figure 1

	A	B	C	D	E	F	G
DHZEENJPGCHL	35 1/4	18 1/8	18	16	15 7/8	18 1/4	16 1/8

CONTENTS

1	Damper rack w/ economizer controls
1	Installation/Component Manual
1	Mixed Air Sensor

ACCESSORIES / CAPABILITIES

Dual Enthalpy - Requires an additional C7400 enthalpy control installed in the return air duct.

Demand Control Ventilation - Requires a CO2 sensor.

IRKT-01 Isolation relay kit is required for heat pump applications

The equation below may be used to set the minimum position. The mixed air temperature and outside air temperature may be discerned by looking at the status menu on the Jade controller.

MINIMUM SET POINT EQUATION

$$(To \times OA) + (Tr \times RA) = Tm$$

To = Outdoor air temperature

OA= Percent of outdoor air

Tr = Return air temperature

RA= Percent of return air

Tm= Resulting mixed air temperature

Example:

Fresh air required is 10% outdoor air.

Outdoor air temperature is 60 degrees F.

Return air temperature is 75 degrees F.

$$(0.1 \times 60) + (0.9 \times 75) =$$

$$6.0 + 67.5 = 73.5$$

Mixed air temperature will be 73.5 degrees F when the OA is 60 degrees F and the RA is 75 degrees F with 10% outdoor air.

Important Notes

- Please see enclosed brochure for Honeywell component trouble shooting instructions as well as instructions for heat pump set up.
- Heat pump applications require Goodman part number IRKT-01 isolation relay kit.
- The fresh air mist eliminator should be flushed periodically with warm soapy water.
- A two stage thermostat is recommended with this accessory.



Figure 3

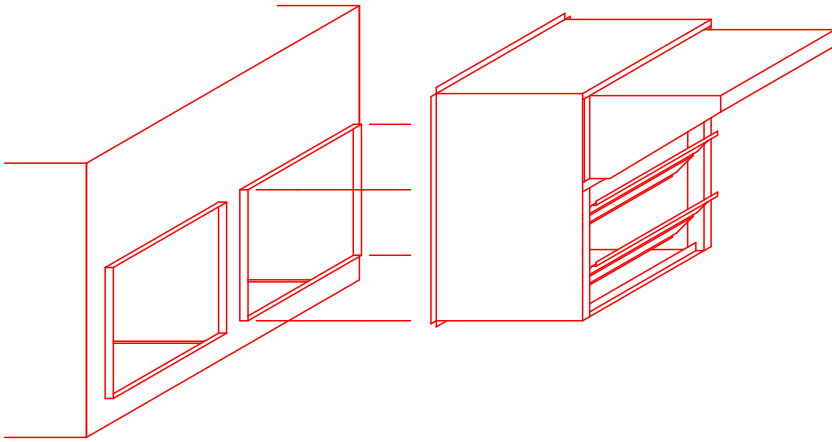

Figure 2



Figure 4



JADE WIRE DIAGRAM 3105 REV4

GROUND

GROUND LUG

MS3105K3052/B
HONEYWELL ACTUATOR

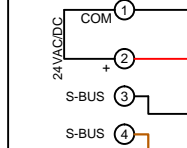

BLACK
RED
WHITE
BROWN

PINK
PINK
WHITE
WHITE
BLACK
RED

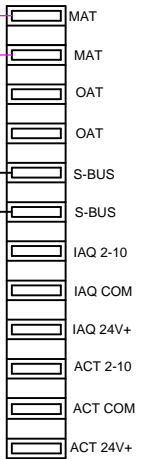

HONEYWELL
W720

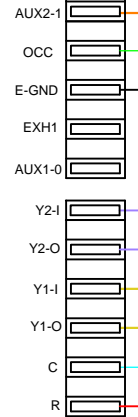

(O)
BLACK
(P)
(P)
(Y)
(Y)
(BL)
(R)

MOLEX 3597706**
50048926-002

COLOR CODES FOR 9 PIN PLUG

- ① (Y) YELLOW
- ② (P) PURPLE
- ③ (P) PURPLE
- ④ (Y) YELLOW
- ⑤ (BL) BLUE
- ⑥ (G) GREEN
- ⑧ (O) ORANGE
- ⑨ (R) RED

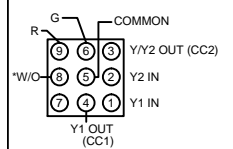

* WHITE WIRE ON DCG
ORANGE WIRE ON DCH

CONNECT TO
C7400S1000
ENTHALPY CONTROL

CONNECT TO
C7250A1001
MIXED AIR SENSOR

