



KEYSTONE RESILIENT SEATED BUTTERFLY VALVES

FIGURE 221 AND 222

An economical bonded resilient seated butterfly valve for bi-directional and end-of-line service

- F221 Wafer style valve
- F222 Lugged style valve



FEATURES

- Bubble tight shut-off at full rated pressure in both directions.
- The F222 lugged version is suitable for bi-directional end-of-line service at full pressure rating.
- Top and bottom bearings absorb side thrust loads.
- A moulded-in O-ring in the seat for flange sealing eliminates the need for flange gaskets.
- Body locating holes for easy installation and centering between flanges.
- Extended neck allows adequate clearance for flange and insulation.

GENERAL APPLICATION

Ideal for building services and irrigation applications that require shut-off control. The valve has a moulded in seat and can be used in full vacuum service.

TECHNICAL DATA

Size range: DN 50-300 (NPS 2-12)
Temperature rating: -30°C to 120°C (-20°F to 250°F)
Pressure rating: Full vacuum to 1600 kPa (250 psi) bi-directional bubble tight shut-off rating. Full 1600 kPa (250 psi) end-of-line shut-off capabilities with F222 lugged valve.
Standard flange drilling: AS 2129 E, ASME Class 125 and 150, JIS table 5 and 10, PN 10 and 16*

NOTE

Other drillings available upon request.
* Not available in all valve sizes.

KEYSTONE RESILIENT SEATED BUTTERFLY VALVES

FIGURE 221 AND 222

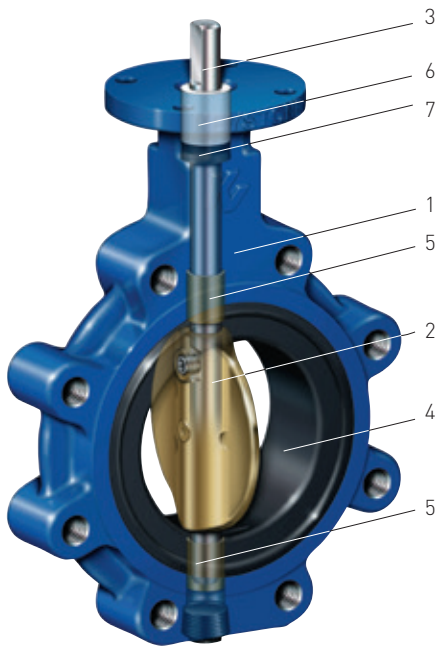

MATERIALS

Part	Material	Material standards
1 Body	Cast iron	ASTM A126 Class B
2 Disc	304 SS	ASTM A351 Grade CF8
	Aluminum bronze	ASTM B148 UNS C95200 Grade A
	316 SS	ASTM A743 Grade CF8M
3 Stem	416 SS	ASTM A582 UNS S41600
4 Molded-in liner	EPDM	
	NBR	
5 Inboard bearings	PTFE/steel	
6 Upper bushing	Polyester	
7 Upper stem seal	NBR	

K_v VALUES vs TRAVEL POSITION

Size (DN)	Angle of opening								
	10°	20°	30°	40°	50°	60°	70°	80°	90°
50	0	1	4	12	22	35	45	51	52
65	0	1	5	18	38	64	93	119	131
80	1	1	7	25	58	99	151	202	227
100	1	13	42	93	170	275	400	509	560
125	3	28	86	178	313	501	720	904	987
150	3	41	125	255	441	700	1003	1254	1366
200	5	73	207	389	649	1029	1517	2063	2501
250	8	115	311	564	920	1455	2183	3110	3972
300	10	166	440	777	1253	1979	3001	4398	5779

NOTE:

K_v is the valve flow capacity expressed as flow rate of water at 20°C, in cubic meters per hour, which produces a 1 bar pressure drop across the valve.

C_v VALUES vs TRAVEL POSITION

Size (NPS)	Angle of opening								
	10°	20°	30°	40°	50°	60°	70°	80°	90°
2	0	1.3	5	14	26	40	52	59	60
2½	0	1.4	6	21	44	74	107	138	150
3	0	1.5	8	29	67	115	175	234	262
4	1	15.0	48	107	196	318	463	589	647
5	3	32.0	99	206	362	579	832	1045	1141
6	4	47.0	145	295	510	810	1160	1450	1580
8	6	84.0	239	450	751	1190	1754	2385	2892
10	9	133.0	360	652	1064	1683	2524	3596	4593
12	12	192.0	509	899	1449	2288	3470	5085	6682

NOTE:

C_v is the valve flow capacity expressed as the flow rate of water at 60°F, in US gallons per minute, which produces a 1 psi pressure drop across the valve.

KEYSTONE RESILIENT SEATED BUTTERFLY VALVES

FIGURE 221 AND 222 - METRIC

F221 WAFER VALVE

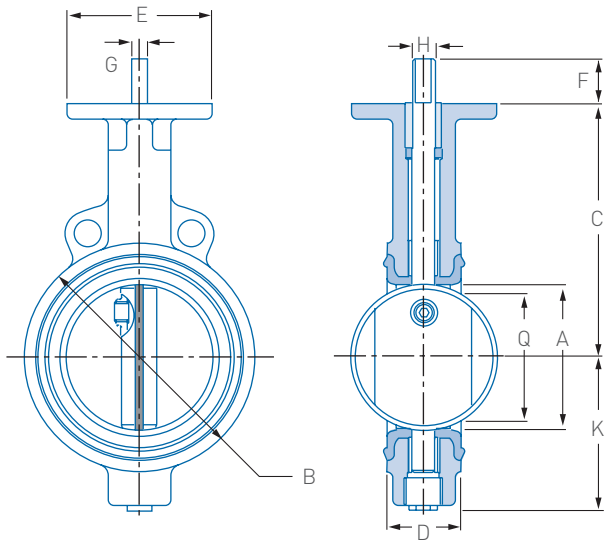

F222 LUGGED STYLE VALVE

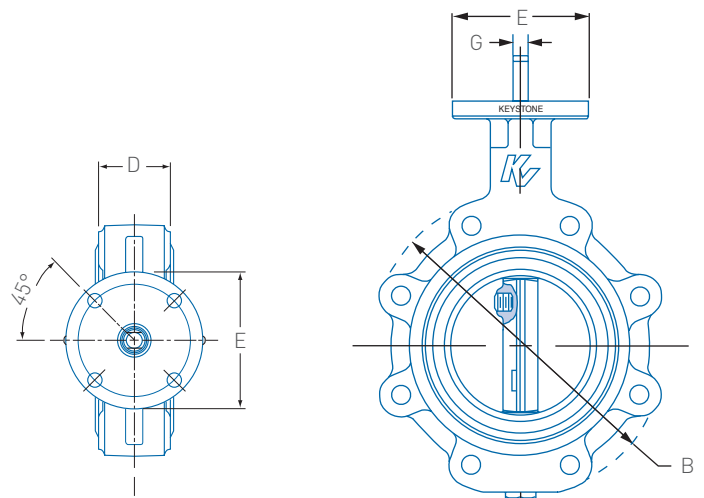

FIGURE 221 DIMENSIONS (mm)

Valve size (DN)	A	B	C	D	E	F	K	Q	Shaft			Top plate drilling			Mass (kg) F221	Stem conn. code
									G inches	H inches	Key inches	PCD	No. of holes	Hole dia.		
50	52	105	136	43	100	32	81	35	9/16	3/8	-	83	4	11	3.8	BAB
65	65	117	150	46	100	32	86	50	9/16	3/8	-	83	4	11	4.2	BAB
80*	78	132	160	46	100	32	95	67	9/16	3/8	-	83	4	11	5.0	BAB
100	103	162	180	52	100	32	108	94	5/8	7/16	-	83	4	11	7.4	BAC
125	129	187	195	56	100	32	130	121	3/4	1/2	-	83	4	11	9.0	BAD
150	148	216	210	56	100	32	144	141	3/4	1/2	-	83	4	11	11.0	BAD
200**	198	271	241	60	150	32	177	190	7/8	5/8	-	127	4	14	17.3	CAE
250	249	330	276	68	150	50	208	241	1 1/8	-	1/4 x 1/4	127	4	14	26.2	CAF
300	300	376	310	78	150	50	239	291	1 1/8	-	1/4 x 1/4	127	4	14	34.5	CAF

FIGURE 222 DIMENSIONS (mm)

Valve size (DN)	A	B	C	D	E	F	K	Q	Shaft			Top plate drilling			Mass (kg) F221	Stem conn. code
									G inches	H inches	Key inches	PCD	No. of holes	Hole dia.		
50	52	121	136	43	100	32	81	35	9/16	3/8	-	83	4	11	4.2	BAB
65	65	133	150	46	100	32	86	50	9/16	3/8	-	83	4	11	5.0	BAB
80*	78	148	160	46	100	32	95	67	9/16	3/8	-	83	4	11	5.4	BAB
100	103	178	180	52	100	32	108	94	5/8	7/16	-	83	4	11	9.8	BAC
125	129	206	195	56	100	32	130	121	3/4	1/2	-	83	4	11	11.7	BAD
150	148	235	210	56	100	32	144	141	3/4	1/2	-	83	4	11	14.1	BAD
200**	198	291	241	60	150	32	177	190	7/8	5/8	-	127	4	14	22.0	CAE
250	249	352	276	68	150	50	208	241	1 1/8	-	1/4 x 1/4	127	4	14	34.5	CAF
300	300	398	310	78	150	50	239	291	1 1/8	-	1/4 x 1/4	127	4	14	48.5	CAF

NOTES

Q The disc chordal dimension at face of valve for disc clearance into pipe fittings or flanges.

H The stem connection diameter.

G The dimension across the stem flats.

* Not available with PN10, PN16 flange drilling.

** Not available with PN16 flange drilling.

Dimensions are nominal ± 1 mm.

KEYSTONE RESILIENT SEATED BUTTERFLY VALVES

FIGURE 221 AND 222 - IMPERIAL

F221 WAFER VALVE

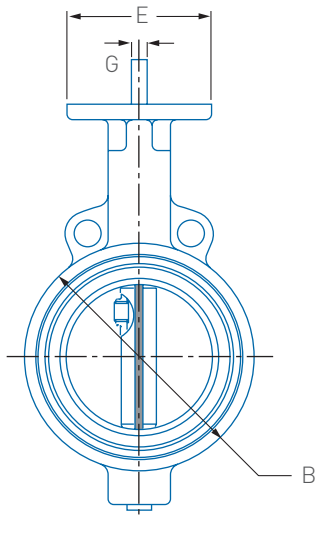

F222 LUGGED STYLE VALVE

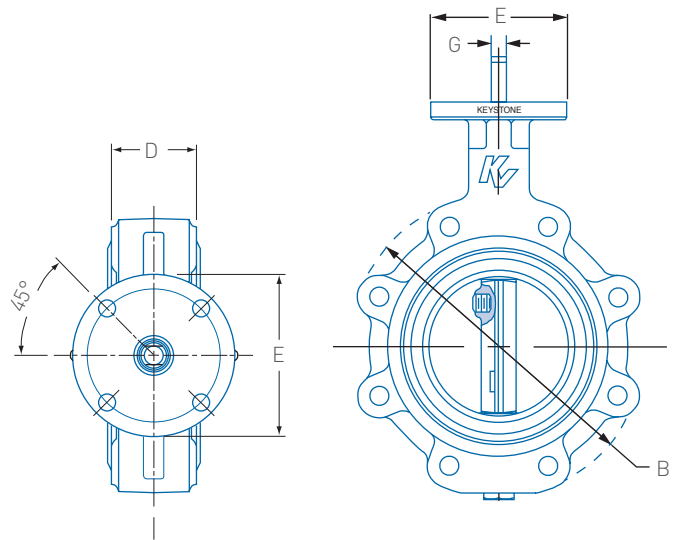

FIGURE 221 DIMENSIONS (inches)

Valve size (NPS)	A	B	C	D	E	F	K	Q	Shaft			Top plate drilling			Weight (lbs) F221	Stem conn. code
									G	H	Key	Bolt circle	No. of holes	Hole dia.		
2	2 1/16	4 1/8	5 5/16	1 11/16	4	1 1/4	3 3/16	1 3/8	9/16	3/8	-	3 1/4	4	7/16	7.7	BAB
2 1/2	2 9/16	4 5/8	5 15/16	1 13/16	4	1 1/4	3 3/8	2	9/16	3/8	-	3 1/4	4	7/16	8.8	BAB
3	3 1/16	5 3/16	6 5/16	1 13/16	4	1 1/4	3 3/4	2 5/8	9/16	3/8	-	3 1/4	4	7/16	10.2	BAB
4*	4 1/16	6 3/8	7 1/8	2 1/16	4	1 1/4	4 1/4	3 11/16	5/8	7/16	-	3 1/4	4	7/16	16.9	BAC
5	5 1/16	7 3/8	7 11/16	2 1/4	4	1 1/4	5 1/8	4 3/4	3/4	1/2	-	3 1/4	4	7/16	19.9	BAD
6	5 13/16	8 1/2	8 5/16	2 1/4	4	1 1/4	5 11/16	5 5/16	3/4	1/2	-	3 1/4	4	7/16	25.3	BAD
8**	7 13/16	10 11/16	9 1/2	2 3/8	6	1 1/4	6 15/16	7 3/4	7/8	5/8	-	5	4	9/16	40.5	CAE
10	9 13/16	13	10 7/8	2 11/16	6	2	8 1/8	9 3/4	1 1/8	-	1/4 x 1/4	5	4	9/16	61.1	CAF
12	11 13/16	14 13/16	12 1/4	3 1/8	6	2	9 3/8	11 3/4	1 1/8	-	1/4 x 1/4	5	4	9/16	82.7	CAF

FIGURE 222 DIMENSIONS (inches)

Valve size (NPS)	A	B	C	D	E	F	K	Q	Shaft			Top plate drilling			Weight (lbs) F221	Stem conn. code
									G	H	Key	Bolt circle	No. of holes	Hole dia.		
2	2 1/16	4 3/4	5 5/16	1 11/16	4	1 1/4	3 3/16	1 3/8	9/16	3/8	-	3 1/4	4	7/16	9.0	BAB
2 1/2	2 9/16	5 1/4	5 15/16	1 13/16	4	1 1/4	3 3/8	2	9/16	3/8	-	3 1/4	4	7/16	10.5	BAB
3	3 1/16	5 13/16	6 5/16	1 13/16	4	1 1/4	3 3/4	2 5/8	9/16	3/8	-	3 1/4	4	7/16	11.9	BAB
4*	4 1/16	7	7 1/8	2 1/16	4	1 1/4	4 1/4	3 11/16	5/8	7/16	-	3 1/4	4	7/16	21.4	BAC
5	5 1/16	8 1/8	7 11/16	2 1/4	4	1 1/4	5 1/8	4 3/4	3/4	1/2	-	3 1/4	4	7/16	25.7	BAD
6	5 13/16	9 1/4	8 5/16	2 1/4	4	1 1/4	5 11/16	5 5/16	3/4	1/2	-	3 1/4	4	7/16	31.0	BAD
8**	7 13/16	11 7/16	9 1/2	2 3/8	6	1 1/4	6 15/16	7 3/4	7/8	5/8	-	5	4	9/16	48.0	CAE
10	9 13/16	13 7/8	10 7/8	2 11/16	6	2	8 1/8	9 3/4	1 1/8	-	1/4 x 1/4	5	4	9/16	75.8	CAF
12	11 13/16	15 11/16	12 1/4	3 1/8	6	2	9 3/8	11 3/4	1 1/8	-	1/4 x 1/4	5	4	9/16	106.5	CAF

NOTES

Q The disc chordal dimension at face of valve for disc clearance into pipe fittings or flanges.

H The stem connection diameter.

G The dimension across the stem flats.

* Not available with PN10, PN16 flange drilling.

** Not available with PN16 flange drilling.

Dimensions are nominal ± 0.039 inch.

KEYSTONE RESILIENT SEATED BUTTERFLY VALVES

FIGURE 221 AND 222 - METRIC

VALVE SEATING AND UNSEATING TORQUES (Nm)

Application Δp (kPa)	Valve size (DN)								
	50	65	80	100	125	150	200	250	300
I									
350	7	7	14	18	35	48	76	140	188
700	8	7	15	19	36	49	77	143	192
1000	8	8	16	21	38	50	79	148	199
1400	9	9	17	23	41	51	82	155	207
1600	9	9	18	24	43	52	83	158	212
II									
350	9	10	20	26	51	69	109	200	269
700	10	10	21	27	52	70	110	203	273
1000	10	11	22	29	54	71	112	208	280
1400	11	12	23	31	57	72	115	215	288
1600	11	12	24	32	59	73	116	218	293
III									
350	17	17	35	46	89	121	190	350	471
700	18	18	36	47	90	122	191	353	475
1000	18	19	37	49	92	123	193	358	482
1400	19	20	38	51	95	124	196	365	490
1600	19	20	39	52	97	125	197	368	495
IV									
350	24	25	50	65	127	172	272	500	672
700	25	25	51	66	128	173	273	503	676
1000	25	26	52	68	130	174	275	508	683
1400	26	27	53	70	133	175	278	515	691
1600	26	27	54	71	135	176	279	518	696

TORQUE APPLICATION FACTOR CATEGORIES

Application I

Clean liquid lubricating media (water, clean oils, lube oil, mineral oil, etc.); and with no deposit or chemical attack, valve operated at least once a week.

Temperature range from 0°C to maximum temperature rating of the elastomer seat.

Application II

Other liquid media and lubricating gases (aqueous liquids, such as food and beverage, water, etc.); and with minor deposit or chemical attack, valve operated at least once a month.

Temperature range from 0°C to maximum temperature rating of the elastomer seat.

Application III

- Dry non-abrasive media or gases (non-abrasive powders and dry gas); or
- Fluids with moderate deposit or chemical attack; or
- Valves operated less than once a month.

Temperature range from 0°C to maximum temperature rating of the elastomer seat.

Application IV

- Dry abrasive media and degreasing applications (sand, cement, silicone free, oxygen cleaned);
or
- Liquids with severe deposit; or
- Valves not frequently operated (once a year).

All above with temperature range from -10°C to maximum temperature rating of the elastomer seat.

KEYSTONE RESILIENT SEATED BUTTERFLY VALVES

FIGURE 221 AND 222 - IMPERIAL

VALVE SEATING AND UNSEATING TORQUES (in lbs)

Application Δp (psi)	Valve size (NPS)								
	2	2.5	3	4	5	6	8	10	12
I									
50	58	62	125	162	314	427	674	1240	1666
100	60	65	130	171	327	432	685	1266	1702
150	64	72	140	186	350	443	705	1315	1768
200	68	78	149	202	372	453	724	1364	1834
250	72	85	159	218	395	464	744	1413	1900
II									
50	84	88	178	231	448	611	962	1772	2380
100	86	91	183	240	461	616	973	1798	2416
150	90	98	193	255	484	627	993	1847	2482
200	94	104	202	271	506	637	1012	1896	2548
250	98	111	212	287	529	648	1032	1945	2614
III									
50	146	154	312	404	785	1069	1684	3101	4165
100	148	157	317	413	798	1074	1695	3127	4201
150	152	164	327	428	821	1085	1715	3176	4267
200	156	170	336	444	843	1095	1734	3225	4333
250	160	177	346	460	866	1106	1754	3274	4399
IV									
50	209	220	445	577	1121	1526	2406	4429	5950
100	211	223	450	586	1134	1531	2417	4455	5986
150	215	230	460	601	1157	1542	2437	4504	6052
200	219	236	469	617	1179	1552	2456	4553	6118
250	223	243	479	633	1202	1563	2476	4602	6184

TORQUE APPLICATION FACTOR CATEGORIES

Application I

Clean liquid lubricating media (water, clean oils, lube oil, mineral oil, etc.); and with no deposit or chemical attack, valve operated at least once a week.

Temperature range from 32°F to maximum temperature rating of the elastomer seat.

Application II

Other liquid media and lubricating gases (aqueous liquids, such as food and beverage, water, etc.); and with minor deposit or chemical attack, valve operated at least once a month.

Temperature range from 32°F to maximum temperature rating of the elastomer seat.

Application III

- Dry non-abrasive media or gases (non-abrasive powders and dry gas); or
- Fluids with moderate deposit or chemical attack; or
- Valves operated less than once a month.

Temperature range from 32°F to maximum temperature rating of the elastomer seat.

Application IV

- Dry abrasive media and degreasing applications (sand, cement, silicone free, oxygen cleaned);
or
- Liquids with severe deposit; or
- Valves not frequently operated (once a year).

All above with temperature range from 15°F to maximum temperature rating of the elastomer seat.

KEYSTONE RESILIENT SEATED BUTTERFLY VALVES

FIGURE 221 AND 222

SELECTION GUIDE

Example	22L	0100	-	10	S1	SG	E1	A1	K	-	00	000	00
Body style													
22L	Lug												
22W	Wafer												
Size													
0050	DN50/ NPS 2												
0065	DN65/ NPS 2½												
0080	DN80/ NPS 3												
0100	DN100/ NPS 4												
0125	DN125/ NPS 5												
0150	DN150/ NPS 6												
0200	DN200/ NPS 8												
0250	DN250/ NPS 10												
0300	DN300/ NPS 12												
Body													
I0	Cast iron												
Disc													
S0	316 Stainless steel												
S1	304 Stainless steel												
A1	Aluminum bronze												
Shaft													
SG	416 Stainless steel												
Seat													
E1	EPDM												
N1	NBR												
Flange drilling													
Single drilled lug & wafer													
A1	ASME 125/150												
AE	AS2129 table E												
AD	AS 4087 PN16 / AS2129 table D												
J5	JIS B2210 - 5K												
J1	JIS B2210 - 10K												
Multi drilled wafer													
M3	ASME 150/AS 2129 table E												
M6	ASME 150/AS2129 E/AS 4087 PN16												
Actuator mounting													
K	Keystone mount												
Actuation													
00	None												
H1	10 pos handle - blue												
G1	Gear - blue												
G5	Chainwheel - blue												
Special													
000	None												
C22	NSF/ANSI STD 61												
Coating													
00	Standard blue												

Other options are available upon request. Please consult your local sales representative.

Neither Emerson, Emerson Automation Solutions, nor any of their affiliated entities assumes responsibility for the selection, use or maintenance of any product. Responsibility for proper selection, use, and maintenance of any product remains solely with the purchaser and end user.

Keystone is a mark owned by one of the companies in the Emerson Automation Solutions business unit of Emerson Electric Co. Emerson Automation Solutions, Emerson and the Emerson logo are trademarks and service marks of Emerson Electric Co. All other marks are the property of their respective owners.

The contents of this publication are presented for informational purposes only, and while every effort has been made to ensure their accuracy, they are not to be construed as warranties or guarantees, express or implied, regarding the products or services described herein or their use or applicability. All sales are governed by our terms and conditions, which are available upon request. We reserve the right to modify or improve the designs or specifications of such products at any time without notice.

[Emerson.com/FinalControl](https://www.emerson.com/FinalControl)
