

WARNING!

Installation, adjustment, modification, operation or maintenance of the heating system carried out by unqualified personnel may result in property damage, personal injury, and loss of life.

The directions of this installation and maintenance manual must be followed precisely. Contact a qualified service company, service provider or the gas company if support or additional information is required.

CAUTION!

Before placing this boiler in operation observe the safety instructions of this installation and maintenance manual.

CAUTION!

The operating manual is a component of the technical documentation handed over to the operator of the heating system. Discuss the instructions in this manual with the owner or operator of the heating system and ensure that they are familiar with all information required for operation of the heating system.

Keep this installation and maintenance manual available for future reference.

In the Commonwealth of Massachusetts this boiler must be installed by a licensed plumber or gas fitter.



Installation and Service Instructions LoganoUS/CA GC 144 II

Contents

1	Safety considerations	3	13	Start-up protocol	19
1.1	Key to symbols	3			
1.2	Safety instructions	3			
2	Product Description	4	14	Taking the heating system out of operation	20
2.1	Correct use	4	14.1	Normal system shut-down	20
2.2	National regulations	4	14.2	Emergency shut-down procedures	20
2.3	Boiler Operating Conditions	4			
2.4	Tools, materials and accessories	4			
2.5	Disposal	4			
3	Dimensions and Connections	5	15	Boiler inspection and maintenance	20
4	Scope of delivery	6	15.1	Why is regular maintenance important?	20
5	Moving the boiler	6	15.2	Testing the flue system, including combustion air, air inlets and Ventilation openings	20
5.1	Moving the boiler with boiler cart	6	15.3	Inspection of the boiler and burner	20
5.2	Lifting and carrying the boiler	7	15.4	Preparing boiler for cleaning	20
6	Placing the boiler	7	15.5	Cleaning the boiler	21
6.1	Clearances	7	15.5.1	Cleaning the boiler with brushes	22
6.2	Leveling the boiler	7	15.5.2	Wet cleaning (chemical cleaning)	23
7	Boiler installation	7	15.6	Cleaning the burner	23
7.1	Preparing for installation	7	15.7	Maintenance protocol	25
7.2	Connecting the heating system	8	15.8	Troubleshooting the GC 144 II	27
7.3	Electrical connections	9			
7.4	Fuel gas supply connection	10	16	Technical specifications	29
7.4.1	Gas connections	10			
7.4.2	Installation at high altitudes	11	17	Electrical circuit diagrams	30
7.5	Filling heating system and checking for leaks	11			
8	Check openings for combustion air supply and venting	12			
9	Requirements for connection to chimneys or venting systems	13			
10	Flue pipe installation	13			
11	Placing the heating system in operation	14			
11.1	Starting up the GC 144 II	15			
11.1.1	Prepare pressure measurement	15			
11.1.2	Turning on heating system	16			
12	Final start-up procedures	16			

1 Safety considerations

1.1 Key to symbols

Warnings



Warnings in this document are identified by a warning triangle printed against a grey background. Keywords at the start of a warning indicate the type and seriousness of the ensuing risk if measures to prevent the risk are not taken.

The following keywords are defined and can be used in this document:

- **NOTICE** indicates a situation that could result in damage to property or equipment.
- **CAUTION** indicates a situation that could result in minor to medium injury.
- **WARNING** indicates a situation that could result in severe injury or death.
- **DANGER** indicates a situation that will result in severe injury or death.

Important information



This symbol indicates important information where there is no risk to people or property.

Additional symbols

Symbol	Explanation
▶	Step in an action sequence
→	Cross-reference to another part of the document
•	List entry
–	List entry (second level)

Table 1

1.2 Safety instructions

Observe these instructions for your safety.

The burner and control must be correctly installed and adjusted to ensure safe and economical operation of the gas boiler.

Read this installation and maintenance manual carefully and note the details on the boiler nameplate before placing the boiler in operation.

Risk of fatal injury from explosion of flammable gases

If you smell gas there is a danger of explosion.

- ▶ Never work on gas lines unless you are licensed for this type of work.
- ▶ Make sure that a qualified company installs the boiler, connects gas and vent, places the boiler in operation, connects the electrical power, and maintains and repairs the boiler.
- ▶ No open flame! No smoking! Do not use lighters
- ▶ Prevent spark formation. Do not operate electrical switches, including telephones, plugs or door bells.
- ▶ Close main gas valve.
- ▶ Open doors and windows.
- ▶ Warn other occupants of the building, but do not use door bells.
- ▶ Call gas company from outside the building.
- ▶ If gas can be heard escaping, leave the building immediately, prevent other people from entering, notify police and fire departments from outside the building.

Risk to life from electrical shock.

- ▶ Disconnect the power supply to the boiler heating system before conducting any work on it, e.g. turn off the heating system emergency switch outside the boiler room.
- ▶ It is not sufficient just to turn off the control.
- ▶ Do not carry out electrical work unless you are qualified for this type of work.
- ▶ Before disconnect electrical power completely and pad lock to prevent accidental reconnection.
- ▶ Observe the local installation regulations.

Risk of fatal injury from flue gas poisoning

Insufficient ventilation or combustion air availability may cause dangerous flue gas leaks or formation.

- ▶ Make sure that inlets and outlets are not reduced in size or closed.
- ▶ If faults are not corrected immediately, the boiler must not be operated until all faults have been corrected.
- ▶ Inform the system operator and/or owner of the fault and the danger in writing.

When working on the flue gas venting equipment or vent damper leakage of flue gases may endanger the lives of people.

- ▶ Carefully observe proper operation of the vent damper. Do not start up the boiler unless the vent damper is operating properly.
- ▶ Use only original parts when replacing parts.
- ▶ When replacing the vent damper, install the new one in the specified position.

Risk to life by poisoning by spillage of flue gases

- ▶ If the blocked vent switch trips frequently the fault must be corrected and proper operation of the blocked vent switch test must be conducted.

Risk to life by poisoning by leakage of flue gases

- ▶ Make sure that the boiler is not equipped with a thermally controlled flue gas vent damper after the open draft hood.

Risk of fatal injury from neglecting your own safety in case of emergency, such as with a fire

- ▶ Never put yourself at risk. Your own safety must always take priority.

Fire danger due to flammable materials or liquids

- ▶ Make sure that there are no flammable materials or liquids in the immediate vicinity of the boiler.
- ▶ Maintain a minimum distance of 15 inches from the boiler.

Installation and maintenance

- ▶ Observe all current standards and guidelines applicable to the installation and operation of the boiler heating system as applicable in your state or local jurisdiction.
- ▶ Clean and service the boiler system once a year. Check that the complete heating system operates correctly.
- ▶ Immediately correct all faults to prevent system damage.
- ▶ Only use original Buderus spare parts. Losses caused by the use of parts not supplied by Buderus are excluded from the Buderus warranty.

2 Product Description

The boiler is a low temperature gas boiler.

The boiler consists of the following main components:

- Ignition module and adjustable boiler temperature controller
- Boiler jacket and front door
- Boiler block with insulation
- Burner

The ignition module and adjustable boiler temperature controller monitor and control all electrical and operational components of the boiler. The boiler jacket prevents energy loss and acts as soundproofing. The boiler block transfers the heat generated by the burner to the heating water. The insulation reduces energy loss.

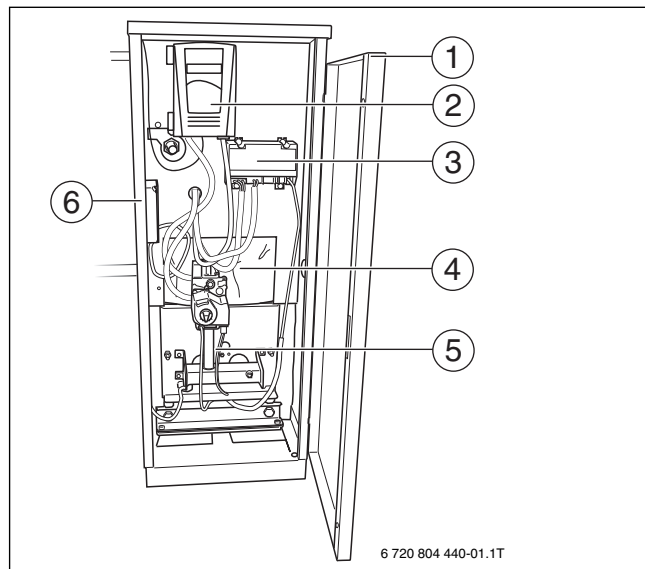

Fig. 1 Logano GC 144 II gas boiler

- [1] Boiler front door
- [2] Boiler temperature controller
- [3] Ignition module
- [4] Boiler block with insulation
- [5] Burner
- [6] Boiler jacket

2.1 Correct use

The Logano GC 144 II atmospheric gas boiler is designed to heat water for a hot water heating system for heating single or multiple occupancy buildings.

2.2 National regulations

The heating system must comply with the relevant regulations issued by national authorities, or the regulations issued by the National Fuel Gas Code, ANSI Z 223.1.

If specified by the local regulatory authorities the heating system must comply with the regulations of the "Standard for Controls and Safety Devices for Automatically Fired Boilers," ANSI/ASME CSD-1. Carbon monoxide detectors must be installed as specified by the local regulations. The boiler must be serviced annually (→ chapter 15, page 20).

2.3 Boiler Operating Conditions

The hot water piping system must comply with the current legislation and local regulations. If an existing boiler is replaced, the complete hot water piping system must be inspected to ensure that it is in perfect condition to ensure safe operation.

Maximum boiler temperature:	220 °F
Maximum operating pressure:	58 psi

Table 2 Boiler Operating Conditions

2.4 Tools, materials and accessories

You need standard tools for the installation and maintenance of the boiler as used in boiler heating system installation and oil, gas and water installations.

The following additional items will also be useful:

- Boiler cart with strap.
- Cleaning brushes and/or chemical cleaning agents for wet cleaning of the cast iron heat exchanger.

2.5 Disposal

- ▶ Dispose of the packaging material in an environmentally prudent fashion.
- ▶ Dispose of any components of the heating system that require replacement in an environmentally prudent fashion.

3 Dimensions and Connections

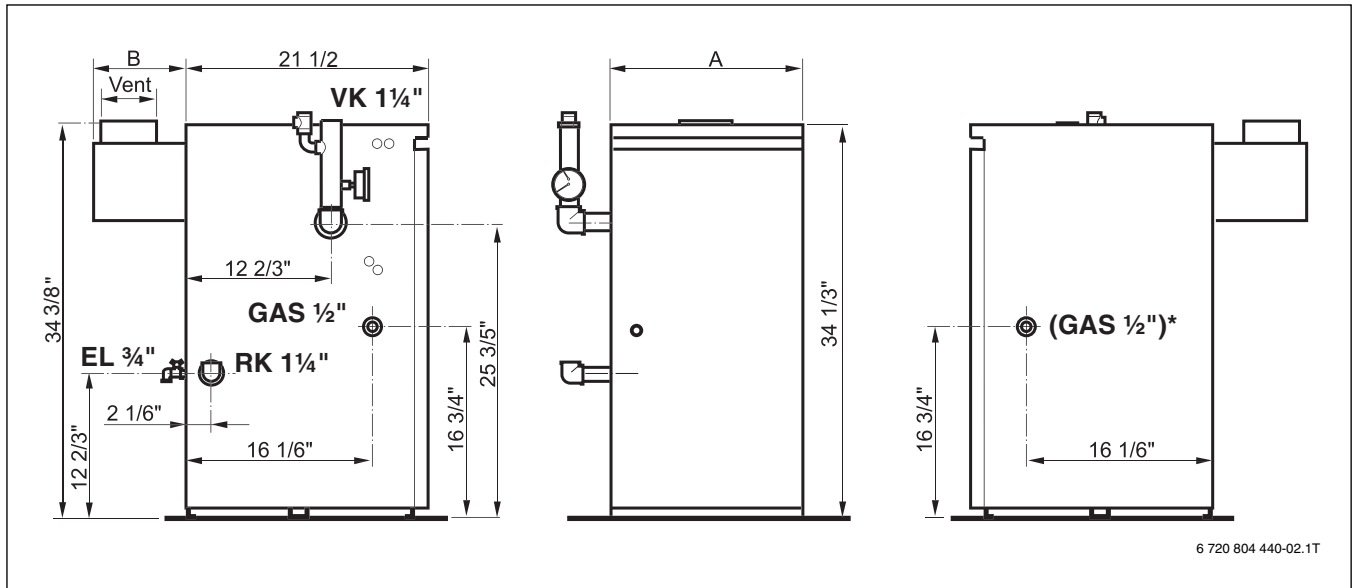

Fig. 2 Back, side and front view, measurements in inches

- * optional connection
- VK Boiler supply
- RK Boiler return
- EL Boiler drain
- GAS Gas connection

Dimensions

Boiler size	Boilerinput Btu/hr	A Inches	B Inches	Vent connection H Inches	Min. relief valve capacity lb/hr	Number of Orifices Qty.	Water volume US Gal.	Dry weight lbs
18/3	74000	13 1/8"	8"	5"	62	2	2.4	228
25/4	103000	16 3/4"	8 2/3"	5"	86	3	2.9	287
32/5	132500	20 3/8"	9 1/2"	6"	110	4	3.4	349.5

Table 3 Dimensions/specs for GC 144 II



For the size and dimensions of the main gas orifices, refer to chapter 16, page 29.

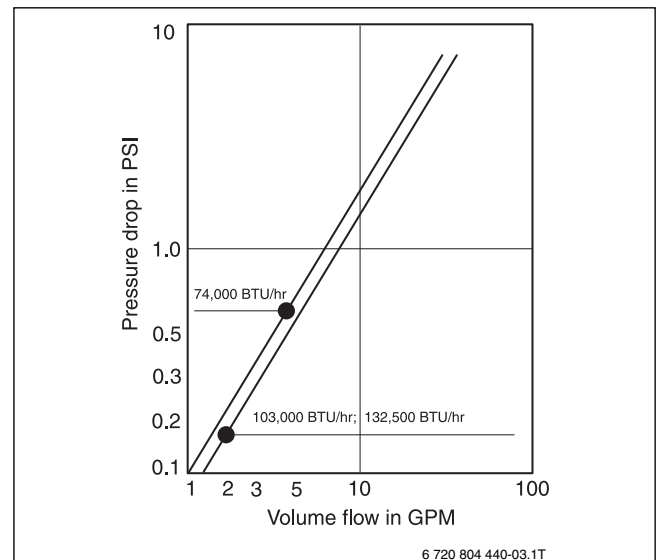

Fig. 3 Pressure drop/boiler

4 Scope of delivery

- ▶ Check packaging upon receipt of delivery for damage.
- ▶ Check delivery for completeness.

Component	Qty	Packaging method
Boiler, complete	1	1 pallette
B-kit components:	1	1 cardboard box ¹⁾
<ul style="list-style-type: none"> • 1-1/4" supply manifold • 30 psi relief valve • long shank boiler drain (3/4") • 1/4" pressure/temperature gauge • 90°-elbow (1 1/4" x 1" NPT) • 90°-elbow (1 1/4" x 1 1/4" NPT) • 90°-elbow (3/4" NPT nipple) • nipple 1" NPT • nipple 1 1/4" NPT 		
Vent damper	1	1 cardboard box ¹⁾
Circulator with whip	1	1 cardboard box ¹⁾
Technical documents		1 plastic package

Table 4 Scope of delivery

1) On Palette

Accessory	Qty
Cleaning Brush	1

Table 5 Scope of delivery

5 Moving the boiler

This chapter describes how to move the boiler safely into place.



NOTICE: System damage due to uneven and rough surfaces.

- ▶ Observe the transport diagrams on the packaging to protect the sensitive components from damage due to rough surfaces. Handle the product with care.



Protect all boiler connections from dirt if the boiler is not installed immediately following removal from packaging.



Dispose of the packaging material in an environmentally prudent fashion.

5.1 Moving the boiler with boiler cart

Move the boiler with packaging in tact and on its pallet as much as possible.

- ▶ Remove packaging straps and cardboard box from pallet.

- ▶ Remove screws that secure the boiler base to the wood pallet.
- ▶ Pick up boiler base from one side and slide to the edge of the pallet. Place a steel pipe as roller under the boiler base. Place additional steel pipes under the boiler base and roll the boiler to its final destination.

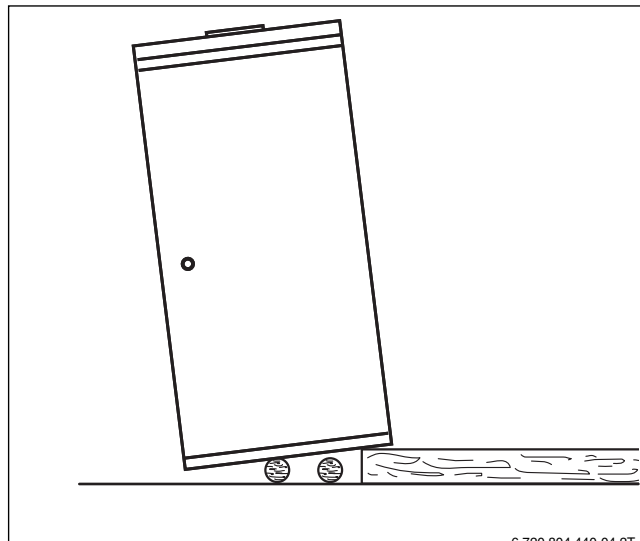

Fig. 4 Moving the boiler with rollers



CAUTION: Risk of injury due to improper securing of the boiler during transport.

- ▶ Use a boiler coat or dolly and strap for moving the boiler
- ▶ Secure boiler on the boiler cart.
- ▶ Remove the front door during lifting or transport to prevent unintentional opening.

- ▶ Set the boiler cart or dolly on the front side of the boiler and put a piece of cardboard between the two to prevent scratches.

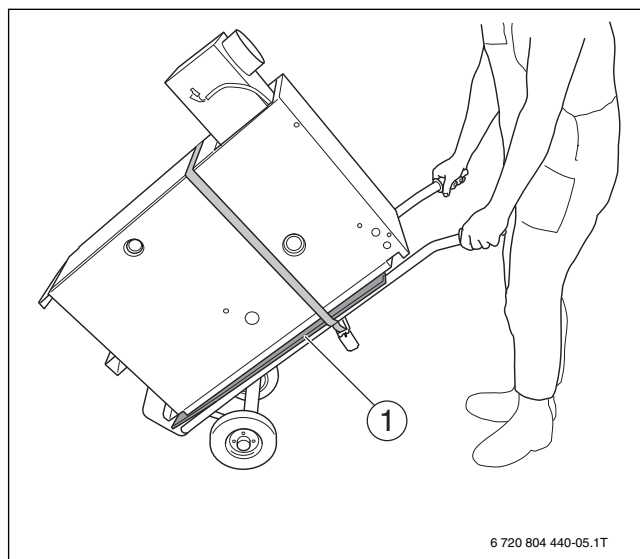

Fig. 5 Moving the boiler with drolley or boiler cart.

[1] Additional card board for protection.

- ▶ Secure boiler on the boiler cart.
- ▶ Move boiler to desired location.

- ▶ Place the boiler at its final position.

5.2 Lifting and carrying the boiler

The boiler can be picked up at the both long sides of the boiler as shown.



CAUTION: Risk of injury due to carrying heavy loads.

- ▶ Lift and carry the boiler with at least four people at the designated side panel locations.

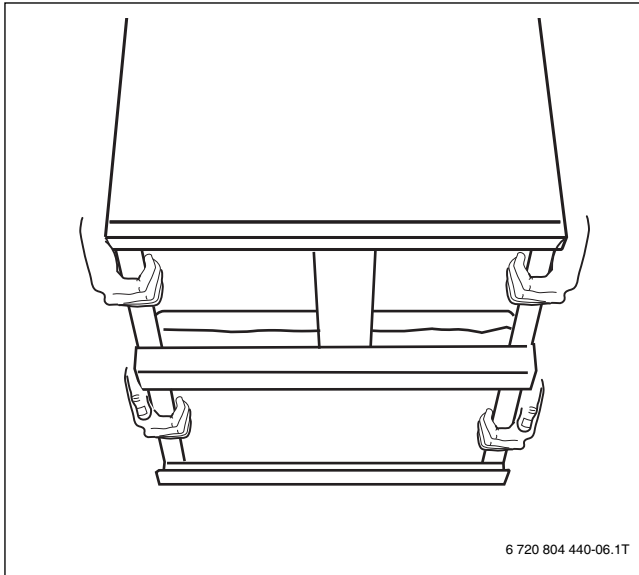

6 720 804 440-06.1T

Fig. 6 Lifting and carrying the boiler

6 Placing the boiler

This chapter explains how to place the boiler and position it in the boiler room.



NOTICE: System damage due to frost.

- ▶ Place the boiler in a frost-free room.

The boiler is very heavy when filled with water. Check that the floor can bear the weight before installation.

6.1 Clearances

The GC 144 II boiler is approved for closet installation. The following minimum distances must then be maintained:

- front: 2",
- sides: 2",
- behind open draft hood: 6",
- above boiler top panel: 30".

A space of at least 33 inches is recommended in front of the boiler with the door removed to allow sufficient access space for operation and maintenance. When the door is closed, a minimum clearance of 2 inches is required at the front and sides, 2 inches clearance is also required for the flue pipe and 30 inches clearance to the ceiling. The installation location and the base must be smooth and horizontal. The boiler may be installed on a flammable base, but not on carpet.

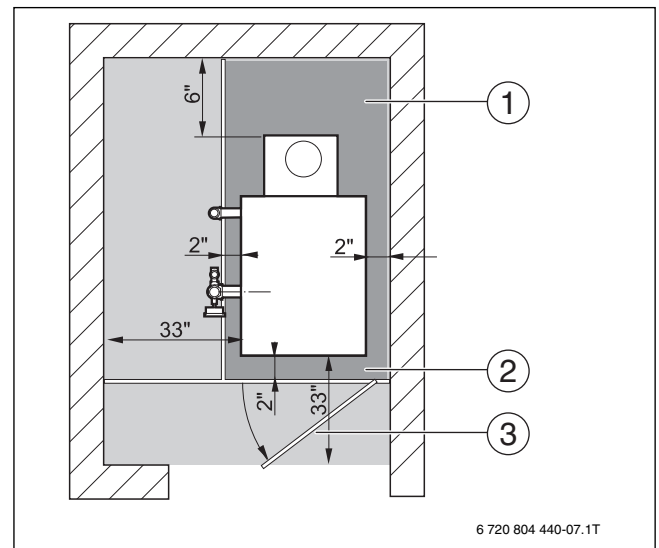

6 720 804 440-07.1T

Fig. 7 Required clearances in the boiler room

- [1] Recommended service clearances
- [2] Required minimum clearances
- [3] Burner tray access door with combustion air opening as required per ANSI Z.223.1

6.2 Leveling the boiler

Level the boiler in both horizontal directions.

- ▶ Level the boiler using a level and place small wedges (not supplied) for leveling purposes.

7 Boiler installation

This chapter describes how to install the boiler. This includes the following tasks:

- Connecting the heating system
- Electrical connection
- Gas supply piping connection

7.1 Preparing for installation

- ▶ Unpack all boxes and containers and check all parts against the packing lists to make sure that everything has been supplied.



Every boiler is carefully inspected and tested before it leaves the factory. However, if you discover any damage or missing parts, please inform your supplier immediately. Before disposing of packing material, make sure that no parts are still in it.



For better access remove the front door.

7.2 Connecting the heating system



NOTICE: Boiler damage due to moisture.

- Protect the components of the gas ignition system from moisture (dripping, spray, rain) during installation of the boiler, during operation and during maintenance work (such as replacing the pump, replacing the control, etc.).



NOTICE: System damage due to overheating as a result of a low water condition.

- Note that a boiler installed above the level of the heating system must be equipped with a low-water cut-off. The low-water cut-off must be installed during installation of the boiler and placed above the water level in the boiler without any means of shutting the water off between the boiler and low water cut-off (→ figure 8).



NOTICE: System damage due to high temperature variations in the heating system.

- If the boiler is operated in connection with a refrigeration system, make sure that the pipes for the refrigerated liquid are connected in parallel to the boiler system with suitable valves to prevent the refrigerated liquid from entering the boiler.
- The piping system of a boiler connected to the heating coils of hydro-air heating systems that may be exposed to the circulation of cooled air must be equipped with a flow-control valve or some other automatic system for preventing the boiler water from circulating by gravity during the cooling cycle.

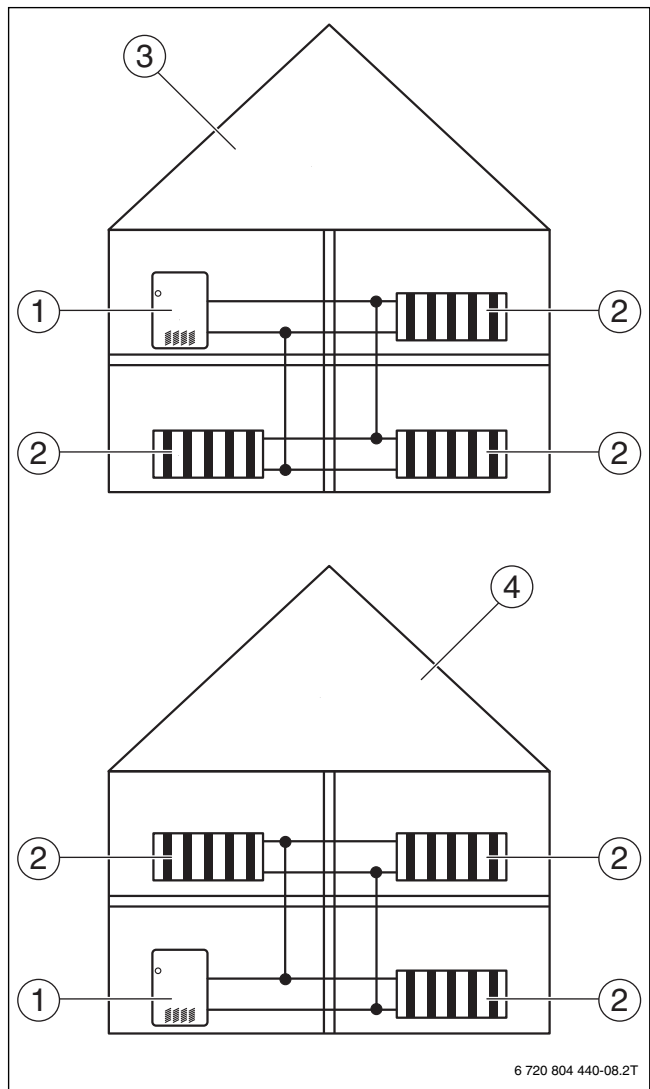

6 720 804 440-08.2T

Fig. 8 Low-water cut-off installation

- [1] Boiler
- [2] Radiator
- [3] Heating system with low-water cut-off
- [4] Heating system without low-water cut-off

Installation of B-kit

The relief valve and the pressure/temperature gauge are mounted on the boiler supply manifold which is attached to the VK (supply) connection of the boiler (included in B-kit).

Installing boiler supply VK:

- ▶ Remove factory installed plastic inserts from boiler supply (VK), boiler return (RK) and boiler drain (EL) connections.
- ▶ Install the 1¼ " NPT nipple into boiler supply, the 1" NPT nipple into boiler return and ¾ " male NPT drain valve into boiler drain connection.
- ▶ Install 90° 1¼ " x 1¼ " NPT on 1¼ " NPT supply nipple and face upward and install 90° 1¼ " x 1" NPT elbow on return nipple and face in desired direction.
- ▶ Install GC 144 II 1¼ " x 1¼ " NPT supply manifold into supply connection (VK) of the boiler. Do NOT place on return connection of the boiler!
- ▶ Install first 90° ¾ " street elbow in upper ¾ " NPT tapping of GC 144 II 1¼ " supply manifold and install pressure relief valve into this ¾ " tapping. Make sure to orient the discharge of the relief valve horizontally. Install the temperature/pressure gauge in the lower ¾ " tapping. Install the temperature/pressure gauge in the lower ¾ " tapping of the supply manifold.

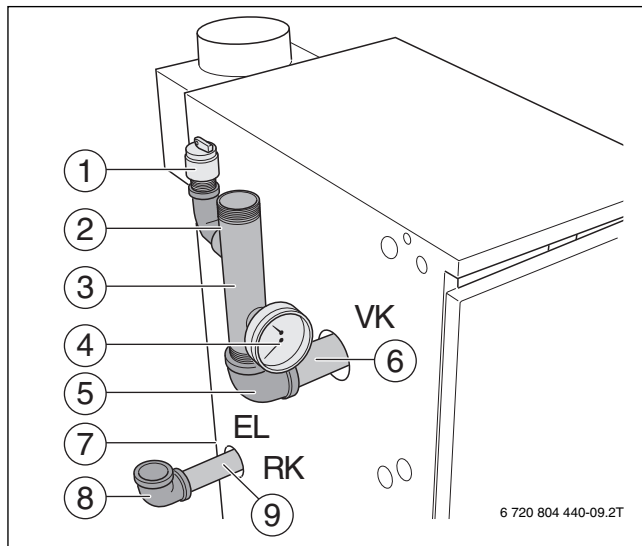

Fig. 9 Installation of B-kit

- [1] Pressure relief valve ¾ "
- [2] 90° ¾ " street elbow
- [3] GC 144 II 1¼ " supply manifold
- [4] Temperature/pressure gauge
- [5] 90° 1¼ " NPT elbow
- [6] 1¼ " x 1" NPT nipple
- [7] Boiler drain ¾ " NPT (backside of boiler)
- [8] 90° 1¼ " NPT elbow
- [9] 1" NPT nipple



Install the relief valve after the leak test (→ chapter 7.5, page 11).
The relief valve must be installed in a vertical position.
The relief valve must also be installed in accordance with the requirements of the ANSI/ASME Boiler and Pressure Vessel Code, Section IV.



We recommend installing a y-strainer (accessory) in the boiler return connection to reduce built-up of debris on the water side inside the boiler.



Ensure compliance with all state and local regulations pertaining to the installation of boiler systems.



WARNING: Fire danger due to exposure to hot water pipes.

- ▶ Maintain a minimum clearance of two inches between non-insulated pipes carrying hot water and combustible walls and surfaces in the boiler room. A minimum of 1" high quality pipe insulation is required to permit direct contact with combustible surfaces.

7.3 Electrical connections

The electrical connections of the boiler must be made as specified by the local codes and the current regulations of the National Electrical Code, ANSI/NFPA-70.

The boiler must be grounded as specified by the regulations of the relevant local authorities; otherwise follow the regulations of the National Electrical Code, ANSI/NFPA-70.

The boiler is fully functional with the factory installed aquastat and the field installed vent damper and heating system circulation pump.



When making the electrical connections please observe the following guidelines:

- ▶ Perform only electrical work, if you possess the required certification for such work. When you do not have the required certification, have the electrical work performed by a certified electrician.
- ▶ Observe all local and state installation regulations.

Power supply connection.

Install incoming power to the boiler per local and state codes.

- ▶ Install an ON/OFF switch near the boiler per local code requirements.

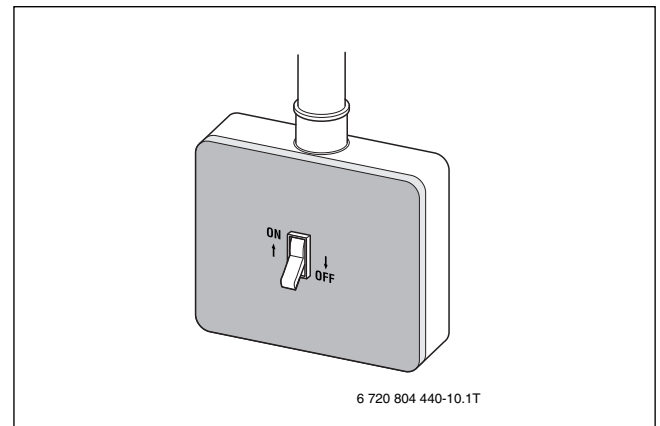

Fig. 10 ON/OFF switch (emergency shutoff switch)

Description of field installed wiring connections using factory supplied junction box.

- ▶ Remove two knock-outs from the left side of boiler panel to route electrical feed and pump power into junction box.
- ▶ Route electrical power from the outside into junction box.
- ▶ Install a metal strain relief for the incoming power line on outside of left boiler jacket panel. (→ figure 12).
- ▶ Just use supplied wiring nuts and double proper wiring before powering up the boiler.



When making the electrical connections use only wires that are approved for electrical use.



Refer to the wiring diagrams for electrical details (→ chapter 17, page 30) .



WARNING: Risk to life from electrical shock.

- ▶ When conducting maintenance work label all cables before disconnecting them.
- ▶ If cables are connected incorrectly the system may not operate correctly with possibly dangerous consequences.

- ▶ Check that the heating system functions correctly after any maintenance work.



WARNING: Fire danger.

- Hot boiler components may damage electrical wiring.
- ▶ Make sure that all cables are routed in the ducts or on the boiler insulation.

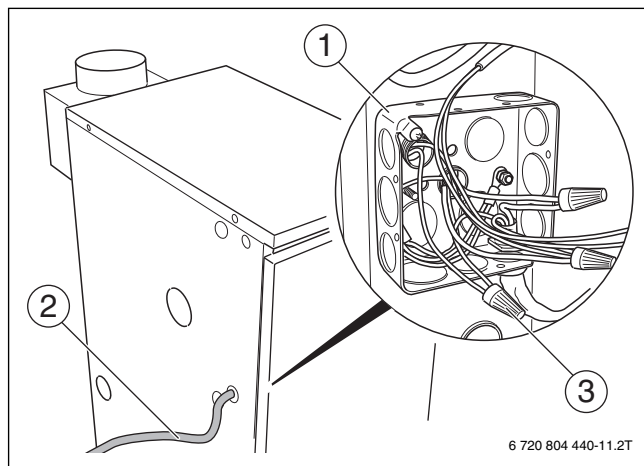

Fig. 11 Electrical junction box

- [1] Electrical junction box (Inside of jacket cabinet)
- [2] Incoming line voltage wiring
- [3] Furnished wiring nuts.

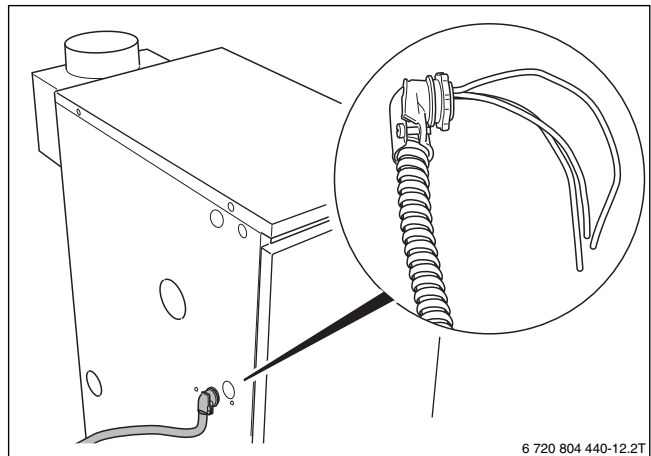

Fig. 12 Strain relief for shielded electrical wiring

7.4 Fuel gas supply connection

7.4.1 Gas connections

For the gas pipe diameter required for the installation please see table 6 and table 7 (→ page 11). Make sure that the pipe fitting has the correct thread size.

Make sure that a sediment trap is installed at the inlet for the gas supply pipe to the boiler. A manual stop valve must be installed outside the boiler jacket if required by the local code. We recommend installing a manual shut-off valve in the main gas pipe to the boiler. The gas pipe must be fastened outside the boiler.

The local codes must be observed during installation of the gas piping connections, otherwise the regulations of the National Fuel Gas Code, ANSI Z 223.1 must be followed.

- ▶ Install gas piping without any undue stress on the piping.
- ▶ The Commonwealth of Massachusetts prohibits the use of copper tubing for the gas line.



WARNING: Danger of explosion.

Leakage from the gas pipes and gas connections may cause an explosion.

- ▶ Use soap solution to find leaks.

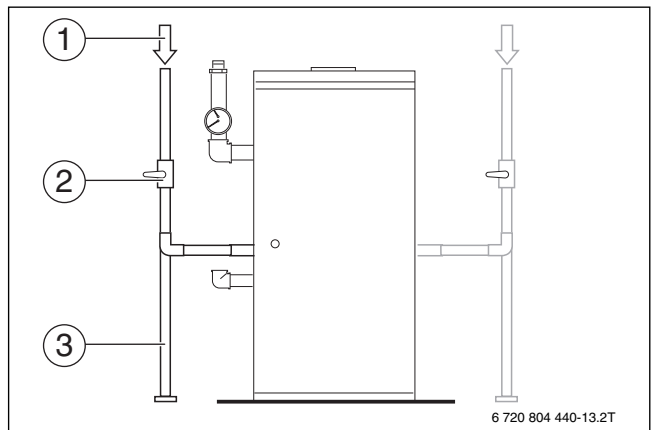

Fig. 13 Gas piping connection to gas valve – right or left side

- [1] Gas feed
- [2] Manual shut-off valve
- [3] Sediment trap

Gas carrying capacity (→ chapter 16, page 29)

Nominal diameter of iron pipe (inches)	Equivalent lengths for pipe fittings in feet			
	Pipe fitting type			
	90°-angle	T-piece	Shut-off valve	Gas shut-off
Equivalent lengths in feet				
1/2	1.4	2.7	0.3	0.80
3/4	2.1	4.1	0.5	1.25
1	2.6	5.2	0.6	1.6
1 1/4	3.5	6.9	0.8	2.15
1 1/2	4.0	8.0	0.9	2.50

Table 6 Equivalent lengths for pipe fittings

Length of pipe in feet	Gas pipe supply volume in cubic feet of gas per hour ¹				
	1/2	3/4	1	1 1/4	1 1/2
10	132	278	520	1060	1600
20	92	190	350	730	1100
30	73	152	285	590	890
40	63	130	245	500	760
50	56	115	215	440	670
75	45	93	175	360	545
100	38	79	160	305	480
150	31	64	120	250	380

Table 7 Gas pipe supply volume

1 Maximum gas supply volume in cubic feet per hour, based on a specific gas weight of 0.60 and a gas pressure of 0.5 psi or less and a pressure gradient corresponding to a water column of 0.3 inches.

Disconnect the boiler with the manual shut-off valve and physically separate the boiler from the gas piping if the gas piping system is pressure tested with a test pressure greater than 1/2 psi.

If the gas supply pipe system is pressure tested at a test pressure of 1/2 psi or less, it is sufficient to disconnect the boiler from the gas pipe system by closing the manual shut-off valve.

Use only sealant that is resistant to corrosion by LPG for pipe connection. Only a small amount of sealant must be applied to the external thread of the pipe connections.

If you wish to convert the boiler to propane, please contact Buderus for the required conversion components. Do not attempt to convert the boiler without the approved Buderus propane conversion parts and the relevant technical documentation. The technical documentation is included with the propane conversion parts.

7.4.2 Installation at high altitudes

The boiler is designed for installation at altitudes below 8500 feet above sea level.



If the installation location is over 8500 feet above sea level, please contact Buderus for another product option as the GC 144 II is not approved above 8500 feet operation.



NOTICE: System damage due to dirt.

If the boiler is assembled and not in use, note the following:

- ▶ Protect the boiler connections from dirt by closing the connections.

7.5 Filling heating system and checking for leaks

The boiler is tested for leaks at the factory. Before placing the heating system into use, check the entire system for soundness to avoid leaks occurring during operation.

Water treatment



Have the water analyzed before filling the heating system. The water may require treatment as a result of the analysis.

Please consult the local water supply company if the water is extremely hard or has a pH level below 7.0.



NOTICE: System damage due to overpressure during the leak test. Pressure, control or safety components may be damaged by high pressure.

- ▶ Before conducting the leak test make sure that no pressure, control or safety components that cannot be disconnected from the water compartment of the boiler are installed.

Carry out the leak test at 1.5 times the normal operating pressure and as specified by the local codes as follows:

Maximum operating pressure	Maximum test pressure
30 psi (based on supplied relief valve)	45 psi
58 psi (with special relief valve)	75 psi

Table 8 Pressure Test

- ▶ Close connection for relief valve (→ figure 14, page 12) and all other open connections with plugs.
- ▶ Disconnect the expansion tank from the system by closing the expansion tank shut-off valve.
- ▶ Open mixing and shut-off valves on hot water side.
- ▶ Fill boiler slowly with water from the feed water connection.
- ▶ Open automatic vents slightly to allow the air to escape.
- ▶ Slowly fill heating system. Observe pressure display on pressure gauge during this process.
- ▶ Check connections and pipes for leaks.
- ▶ Bleed heating system through the bleed valves on the radiators or other air elimination components or high points in the system.
- ▶ If the pressure drops during air bleeding, water must be added.
- ▶ Install pressure relief valve (→ figure 14, page 12).

- ▶ Open fill valve for additional filling.
- ▶ Set static system pressure to at least 15 psi as indicated on pressure relief valve (→ figure 15).
- ▶ Close fill valve and remove fill hose for fill valve.

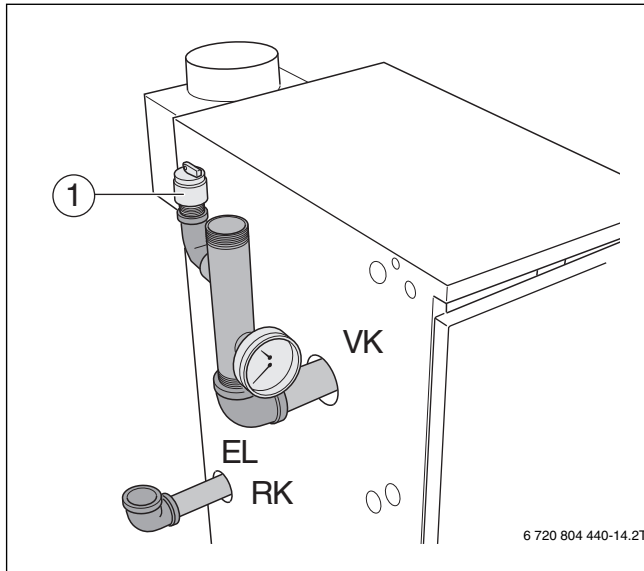

Fig. 14 B-kit installation

- [1] Pressure relief valve 3/4"

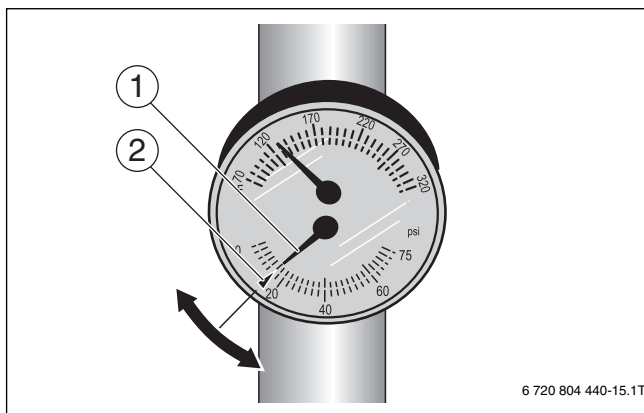

Fig. 15 Pressure temperature gauge

- [1] Pressure gauge
- [2] Set pressure mark

8 Check openings for combustion air supply and venting



NOTICE: Boiler damage and operating faults due to missing or inadequate openings for combustion air and venting of the boiler room.

Inadequate venting of the boiler room may result in excessive ambient temperatures. This can damage the boiler.
Inadequate combustion air supply may cause operating faults.

- ▶ Make sure that inlets and outlets are not reduced or closed and that they are adequately dimensioned.
- ▶ If faults are not corrected immediately, the boiler must not be operated
- ▶ Inform the system operator of the fault and the danger.

To ensure an adequate combustion air supply and venting of the heating system suitable measures must be taken in accordance with the National Fuel Gas Code, Section 5.3, Air for Combustion and Ventilation, or the local codes.



NOTICE: Boiler damage due to contaminated combustion air.

- ▶ Never use cleaning agents that contain chlorine and halogenated hydrocarbons (e.g. spray bottles, solvents and cleaning agents, paints, glues).
- ▶ Do not store or use these substances in the boiler room.
- ▶ Prevent excessive dust levels.



WARNING: Fire danger due to flammable materials or liquids.

- ▶ Do not store flammable materials or liquids in the immediate vicinity of the heat generator.

Total air supply from inside the building

Make sure that the boiler room has two permanent openings that are connected with one or more other rooms. When calculating the cross-section areas of the openings, the total combustion output of all gas-fired appliances in the connected rooms must be taken into account. Each opening must have a minimum cross-section of one square inch per 1000 Btu/h of the total combustion output of all gas-fired appliances inside the connected rooms. Note that the minimum cross-section of every opening must not be less than 100 square inches. One opening must not be more than 12 inches from the ceiling and the other must not be more than 12 inches from the floor of the boiler room, calculated from the outer edge of the opening. The shortest dimension of all inlet and outlet openings must not be less than three inches.

Total air supply from outside the building

Make sure that the boiler room has two permanent openings, one of which must not be more than 12 inches from the ceiling and the other must not be more than 12 inches from the floor of the boiler room, calculated from the outer edge of the opening. The openings have a direct connection or a connection through ventilation ducts to the outside or to rooms that have an unobstructed connection to the outside

(crawl space or attic). The shortest dimension of all inlet and outlet openings must not be less than three inches.

- ▶ If there is a direct connection to the outside, each opening must have a minimum cross-section of one square inch per 4000 Btu/h of the total combustion output of all gas-fired appliances inside the closed room.
- ▶ If there is a connection to the outside through vertical ventilation ducts, each opening must have a minimum cross-section of one square inch per 4000 Btu/h of the total combustion output of all gas-fired appliances inside the closed room.
- ▶ If there is a connection to the outside through horizontal ventilation ducts, each opening must have a minimum cross-section of one square inch per 2000 Btu/h of the total combustion output of all gas-fired appliances inside the closed room.
- ▶ If the openings are connected to ventilation ducts, the ducts must have the same cross-section area as the openings.

9 Requirements for connection to chimneys or venting systems

The flue connection must comply with the regulations of the National Fuel Gas Code, Part 7, Venting of Equipment, and the local construction codes.

Flue connections of heating systems with natural venting must not be connected with any component of a mechanically operated venting system that operates with overpressure.

The cross-section of the flue connection must not be less than that specified (→ table 3, page 5).

If the boiler is to be connected to a brick chimney, the chimney must be thoroughly inspected before use. The chimney must be clean, in compliance with construction codes and of sufficient dimensions.

Chimneys with an internal liner are preferred and are only permitted if the liner complies with all national, state and local construction codes. Liners of fire-glazed brick with moisture-proof joints and liners of corrosion-resistant material are recommended. Contact the local gas supply company for advice and recommendations for flue connection and chimney liners. A flue pipe of single-walled sheet metal is required for flue connections for type II models.

An adequate chimney height in compliance with the tables of the National Fuel Gas Code, ANSI Z 223.1, is required.

Separation of a boiler from a common flue system

If an existing boiler is separated from a common venting system, the venting system will then be too large to guarantee correct venting for the heating systems that remain connected to the system.

Test the venting system by the following procedure:

Carry out these steps with every heating system that remains connected to the venting system when the boiler is separated from a common venting system. Every heating system must be started in operation and the other heating systems must remain turned off.

- ▶ All unused openings of the common system must be sealed.
- ▶ Inspect the venting system to ensure that it has the correct dimensions and longitudinal inclination. Make sure that the system is not blocked, leaking, corroded or has any other faults that cause it to operate improperly.

- ▶ If necessary, close all doors and windows in the building and all doors between the space in which the heating systems that remain connected to the venting system are installed and the other rooms of the building. Turn off washing machines and dryers and all appliances that are not connected to the venting system. Run all venting fans and bathroom exhaust fans at maximum speed. Fans in use in summer must remain in operation and oven exhaust system flaps must be closed.
- ▶ Now start the heating system that is to be tested. Follow the instructions for starting. Set the thermostat for continuous operation.
- ▶ After the main gas burner has been operating for five minutes, check the opening at the back flow check for drafts with a match flame or a candle, or with the smoke of a cigarette, cigar or pipe.
- ▶ Then all heating systems that remain connected to the venting system have been checked as above to ensure that the venting operates properly, return all doors, windows, exhaust fans, oven exhaust flaps and all other gas-fired appliances to their original position.
- ▶ Any incorrect status of the common venting system must be corrected to ensure that the heating system complies with the regulations of the National Fuel Gas Code, ANSI Z 223.1. If the size of any component of the common venting system is changed, the complete venting system must be resized to comply with the relevant tables in Part 1.1 of the National Fuel Gas Code, ANSI Z 223.1.

10 Flue pipe installation

This section describes the connection of the flue pipe and venting system. Note that the open draft hood cannot be modified under any circumstances.



The boiler can and may only be operated with the electrical vent damper that is standard supplied with every GC 144 II.

- ▶ The flue collar is factory installed on the flue connection of the open draft hood and fastened with four (4) corrosion-resistant sheet metal screws.

The vent damper supplied with the boiler must be used for venting the boiler only.

The position of the vent damper position blade must be visible.

The open draft hood must be at least six inches from all combustible surfaces.

The vent damper must be freely accessible for maintenance.

The vent damper must be open when the main burner of the boiler is operating.

Installation of vent damper

- ▶ Install pins in the hole of the vent damper blade for the II models only.
- ▶ Fasten vent damper to the flue collar of the open draft hood with three (3) corrosion-resistant sheet metal screws.

Connecting flue pipe

- ▶ Connect flue pipe to the chimney with the shortest possible length of flue pipe.

Use only flue pipes with the proper diameter for the boiler.

Every horizontal section of the flue pipe must have a minimum rise of 1/4 inch per foot towards the chimney. The flue pipe must be securely

fastened to prevent it from hanging. A support must be installed at least every five feet. Fasten every connection with at least three (3) corrosion-resistance sheet metal screws. The end section of the flue pipe must connect to the inside of the chimney smoke duct.

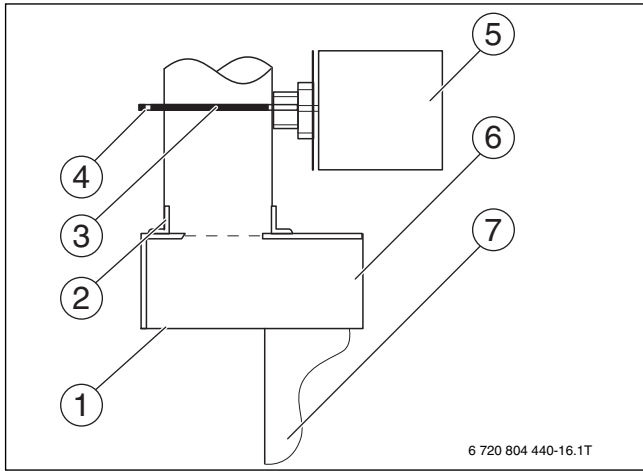

Fig. 16 Installation of vent damper

- [1] Open draft hood
- [2] Vent connection
- [3] Vent damper
- [4] Damper blade position indicator
- [5] Vent damper motor
- [6] Flue gas collector
- [7] Boiler

A minimum clearance of six inches is required between the flue pipes and all flammable materials.

The vent pipe must not be reduced in size and the venting system must not be compromised by the installation of additional appliances.

Electrically connecting the vent damper

- ▶ Disconnect your heating system from the main electricity supply.
- ▶ Route the connection wiring of the vent damper along the left side of the boiler into the opening on the left side of the boiler. Secure strain relief at the furnished knock-out.

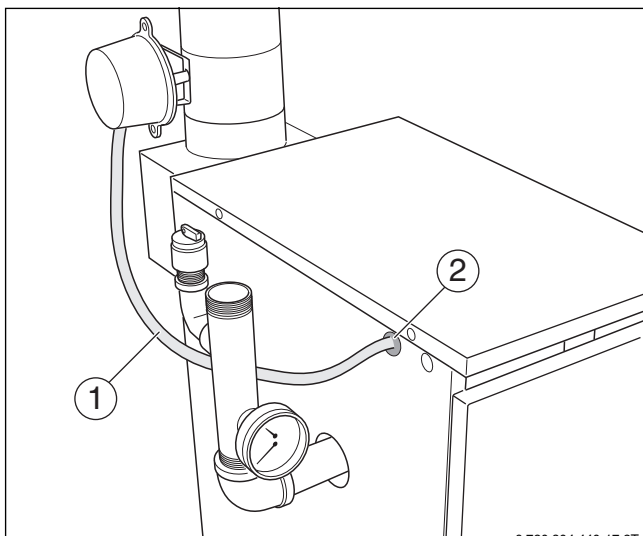

Fig. 17 Routing of vent damper wiring

- [1] Vent damper wiring
- [2] Vent damper wiring strain relief

- ▶ Connect vent damper plug into the terminal bar as shown in the circuit diagram.



All connection points on the complete venting system must be checked for correct installation and sealing immediately after carrying out one of the installation steps. The seams and connections must be checked for gas leaks. Regulations require the complete venting system to be checked at least once a year by a qualified technician after installation and initial operation.

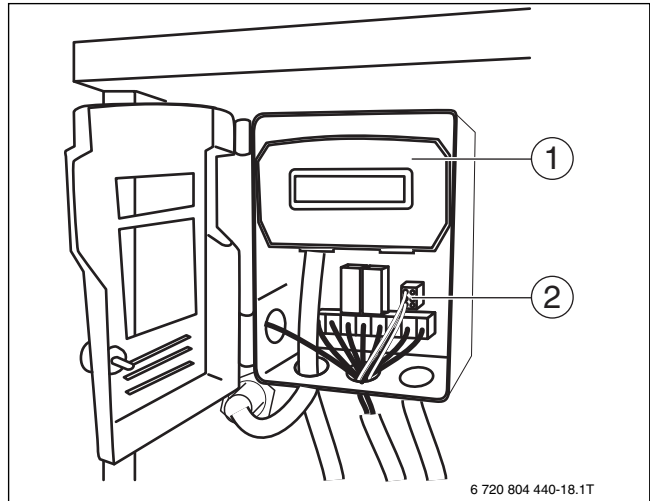

Fig. 18 Connecting vent damper wiring

- [1] Boiler temperature controller
- [2] Vent damper connection plug

11 Placing the heating system in operation

The burner and gas train integrated in the boiler have been tested at the factory as described in ANSI Z 21.13 to ensure safe operation of the heating system and verify specific performance indicators.



WARNING: Risk to life due to electric shock when the cover protecting the electric components has been removed.

Before removing the cover to the electric components:

- ▶ Cut power to the heating system by turning the emergency shut-off switch to the OFF position, or by shutting off the heating system circuit breaker.
- ▶ Take precautions to prevent accidental reactivation.

Preparing for operation

- ▶ Set the room thermostat (optional) to the lowest setting.



WARNING: Risk to life from gas poisoning. Insufficient ventilation can lead to leaking of flue gases.

- ▶ Verify that all combustion air and all flue gas openings are wide open and not obstructed.
- ▶ The boiler must not be placed in operation unless all deficiencies have been removed.
- ▶ Inform the owner and operator of the heating system of any deficiencies in writing.

- ▶ Check all combustion air and all flue gas ducts and openings. (→ chapter 8, page 12 and chapter 9, page 13).

Verifying the appliance

	Main gas orifice identification		
Boiler size	18	25	32
Natural gas	285	275	270
LP	180	175	170

Table 9 Main gas orifice identification. These parts are only valid for the U.S.A. from 0-8500ft in elevation.

- ▶ Fill heating system and bleed the complete system including all radiators and zones.
- ▶ Open front door (→ figure 19).

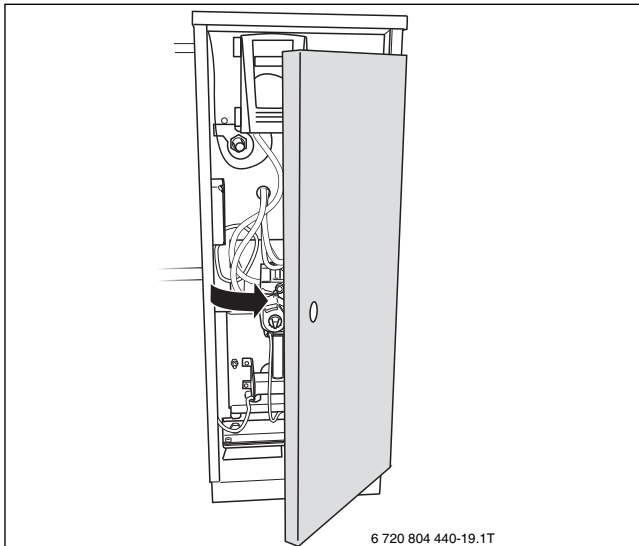

Fig. 19 Opening front door

Testing gas train for leaks

- ▶ Open gas manual shut off in the gas line.
- ▶ Check all gas connections and pipes to the gas valve for leaks using soapy water. If no leaks are found, continue with the step after the next step. If any leaks are found, close gas manual shut off.
- ▶ Seal leaks and repeat the previous step.
- ▶ Wait five (5) minutes until all gas has dissipated. Check for odor of gas around the heating system. This test must also be conducted at floor level, because some gas types are heavier than air and may accumulate at floor level.
- ▶ Follow the safety information on the following pages.

For your own safety, read before boiler start-up.



WARNING: Risk to life due to not observing the start-up instructions and resulting malfunction.

- ▶ If these instructions are not followed exactly, fire or explosion may result causing serious property damage, loss of life, or serious personal injury.
- ▶ Observe the installation instructions.



WARNING: Danger of explosion if you smell gas there is danger of explosion!

- ▶ No open flame! No smoking!
- ▶ Prevent spark generation. Never operate electrical switches, including telephones, plugs or door bells!
- ▶ Close main gas shut-off!
- ▶ Open windows and doors!
- ▶ Warn all occupants of the building!
- ▶ Evacuate the building!
- ▶ Call gas company, heating contractor or fire department from outside the building.



This unit is equipped with an automatic igniter that starts the burner. Do not attempt to ignite the burner manually.



WARNING: Risk to life due to water damage.

- ▶ Do not operate the unit if any part is or was submerged in water.
- ▶ Contact a qualified customer service technician immediately to have the unit checked and all parts of the control and gas valves replaced that were in contact with water.

11.1 Starting up the GC 144 II

- ▶ STOP! First perform a leak test as described on page 15 of this manual.
- ▶ First read the safety instructions on page 15 of this manual.

11.1.1 Prepare pressure measurement

- ▶ Remove the screw plug for the gas pressure measurement port on the gas valve. Install pressure measuring nipple and attach a pressure gauge to measure the gas pressure.
- ▶ Remove the screw plug for the orifice pressure measurement port on the gas valve. Install pressure measuring nipple and attach a pressure gauge to measure the orifice pressure.
- ▶ Open gas shut-off.

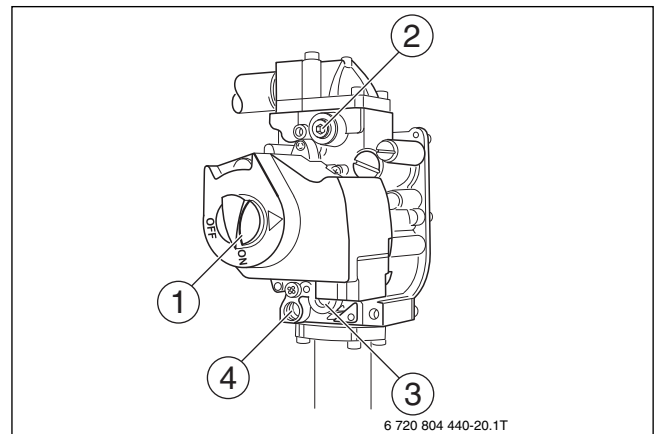

Fig. 20 Gas valve

- [1] ON/OFF knob (shown in ON position)
- [2] Screw plug for gas pressure measurement port
- [3] Screw plug for orifice measurement port
- [4] Ignition gas line connection

11.1.2 Turning on heating system

The boiler is fully functional with the factory-installed boiler temperature controller and field installed and connected vent damper.

- ▶ Switch on power to the heating system, continue to chapter 12.
- ▶ Verify that the thermostat (optional) signals a heat demand to the boiler (set temperature dial at least 10°F above ambient).

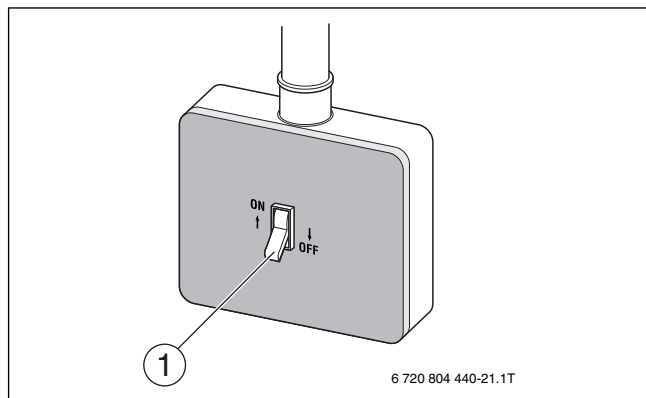

Fig. 21 ON/OFF switch

[1] Emergency shutoff switch

12 Final start-up procedures

Verifying the ignition spark

- ▶ Look through the sight glass at the igniter and verify that a spark is visible.
- ▶ Should no spark be visible continue to troubleshooting in chapter 15.8, page 27.

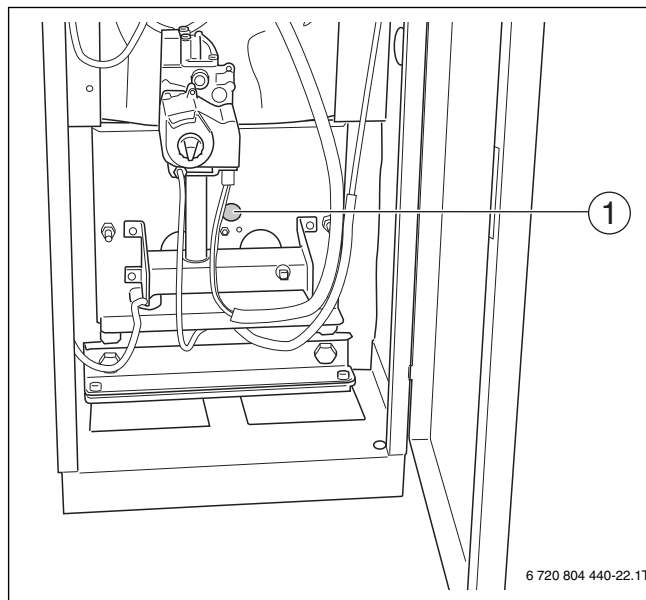

Fig. 22 GC 144 II

[1] Sight glass



WARNING: Risk to life from fire or explosion.

- ▶ Never use excessive force on the ON/OFF knob (→ figure 23).
- ▶ Turn ON/OFF knob only by hand.
- ▶ Never use tools to turn knob.
- ▶ If you are unable to turn the knob by hand, do not try to repair it.
- ▶ Call Buderus technical service for assistance.

- ▶ Turn ON/OFF knob (→ figure 23) counterclockwise to the ON position.
- ▶ The ignition flame will appear and ignite the main burner. If the main burner does not ignite, close the gas shut-off. Disconnect heating system from the power source and inform your customer service technician or gas company.

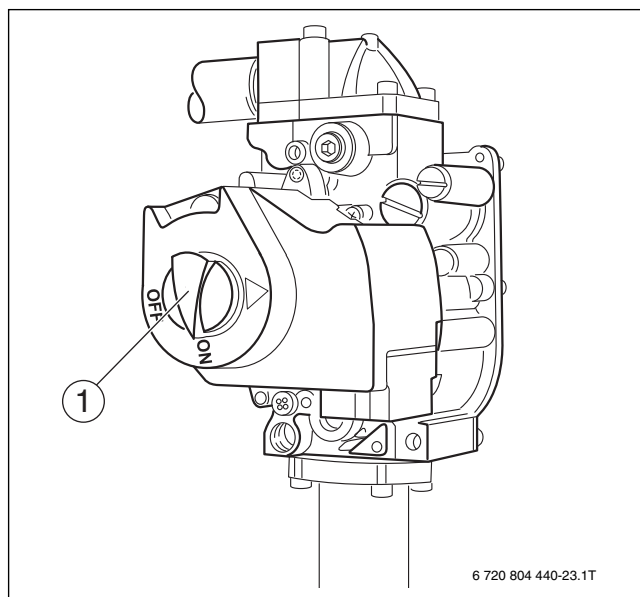

Fig. 23 Gas valve

[1] ON/OFF knob (shown in ON position)

Checking gas supply pressure

- ▶ Check the gas supply pressure while the boiler is operating. The connection pressure for natural gas must be between 4.7" and 10.5" W.C. For propane gas (LP) it must be between 11" and 13" W.C. If the gas pressure is in the correct range, record the measured value in the start-up protocol, then continue with the next step. If the supply pressure does not meet the above criteria, close gas line and contact the gas company.

Checking orifice pressure

- ▶ Compare the orifice pressure with the values in table 10 (→ page 17). If it differs by more than 0.2" W.C., adjust accordingly. To set the orifice pressure, the protective screw on the gas valve must be removed (→ figure 24, page 17). Turn the adjustment screw clockwise to increase the pressure, and counterclockwise to reduce the pressure. This setting must be adjusted while the boiler is operating.

GC 144 II	Natural Gas [inch W.C.]	LP [inch W.C.]
18	3.5	8.8
25	3.5	8.6
32	3.5	8.7

Table 10 Orifice pressure at 60°F / 30" Hg. These values are only valid in the U.S.A. and only for elevations from 0-8500ft.

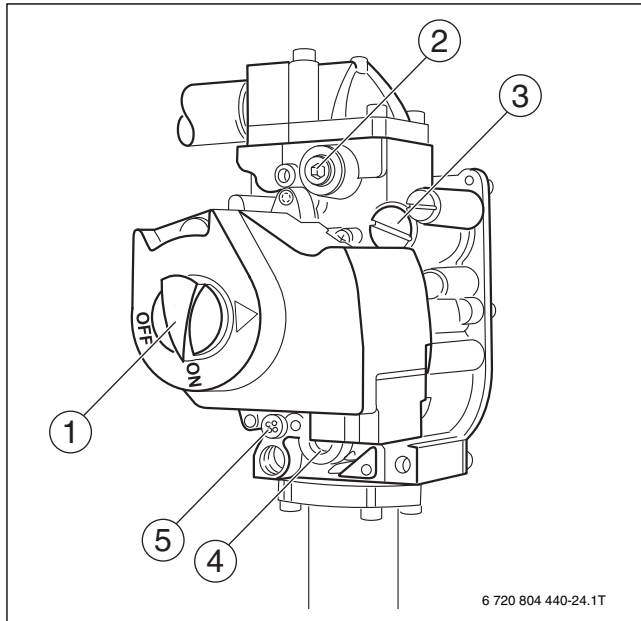

Fig. 24 Gas valve

- [1] ON/OFF knob (shown in ON position)
 - [2] Safety screw on gas supply pressure measurement port
 - [3] Safety screw on orifice pressure adjustment port
 - [4] Safety screw on orifice pressure measurement port
 - [5] Safety screw on ignition gas adjustment screw
- ▶ Record the measured value in the start-up protocol. Install the safety screw back into the gas valve.
 - ▶ Observe main burner flame through the sight glass (→ figure 22, page 16) in the burner plate. The flame must show a steady and stable body and generally be of bluish color. If the main burner flame meets the requirements, proceed to the next step. If the main burner flame is weak, yellow, or goes out, turn the ON/OFF knob (→ figure 26) on the gas valve clockwise to OFF. Close the gas shut-off and disconnect the heating system from the main power source and contact the customer service technician or the gas company.

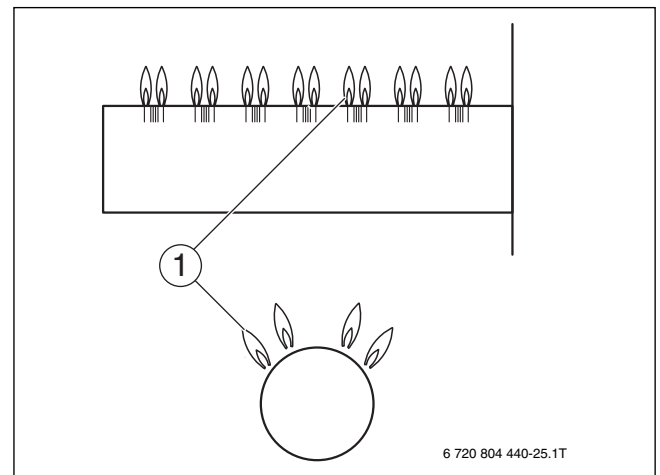

Fig. 25 Main burner

- [1] Main burner flame

Checking flame rod

- ▶ Test the flame rod by closing the gas shut-off. The main burner flame (→ figure 25) and the ignition flame are extinguished. After no more than six (6) seconds the main gas solenoid valve on the gas valve must close with an audible noise. If the gas valve does not operate correctly, turn ON/OFF knob on the gas valve clockwise to the OFF position immediately. Close the main gas shut-off and disconnect the heating system from the main power source and contact the customer service technician or the gas company.

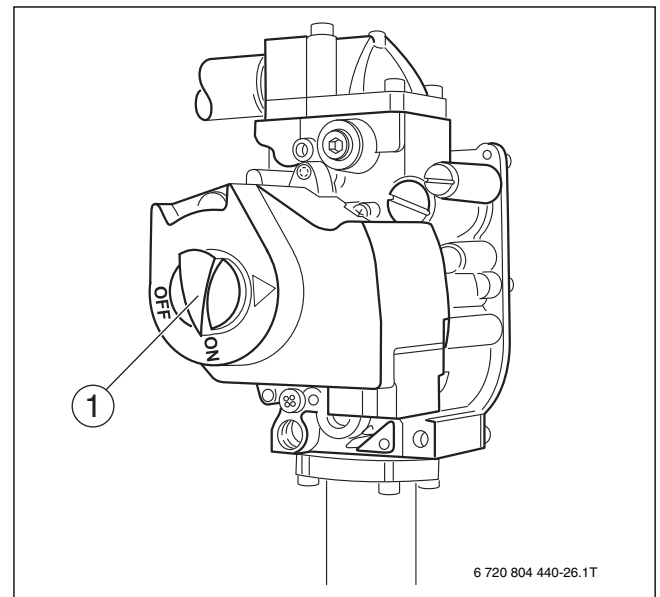



Fig. 26 Gas valve

- [1] ON/OFF knob (shown in ON position)
- ▶ After 90 seconds the igniter stops generating sparks for five (5) seconds.
 - ▶ Disconnect the heating system from the main power source. Open main gas shut-off. A normal operating cycle must follow.
 - ▶ If the main burner flame lights and burns to spec, proceed to the next step. If not, turn knob on gas valve clockwise to OFF position immediately. Close main gas shut-off. Disconnect heating system from the power source and inform the customer service technician or gas company.

- ▶ Turn gas valve ON/OFF knob clockwise to OFF position.
- ▶ Close main gas shut-off.
- ▶ Disconnect heating system from the power source and set the thermostat to the lowest setting.
- ▶ Remove pressure measuring nipple and pressure gauge for measuring gas pressure and orifice pressure from the gas valve, and close the openings with the screw plugs.

Checking for leaks

- ▶ Open main gas shut-off.
- ▶ Set thermostat at least 10°F above ambient to establish a heat demand.
- ▶ Turn main power switch ON.
- ▶ Turn gas valve ON/OFF knob counterclockwise to ON position.
- ▶ After the burner has lit check the gas valve including screw plugs for leaks using soapy water. If no leaks are found, continue with the step after the next step. If leaks are found, close gas shut-off and turn ON/OFF knob on gas valve clockwise to the OFF position. Disconnect the heating system from the power source and turn thermostat to its lowest setting.
- ▶ Seal leaks. Repeat all steps in this paragraph.
- ▶ Carefully wipe away the soapy water to prevent corrosion caused by the alkaline content of the soap.



WARNING: Risk to life due to leaking flue gases.

- ▶ Verify the functionality and operability of the vent damper.

- ▶ Check the position of the vent damper. The damper must be fully open (vertical). When burner is on flue gases must not escape from the vent hood.

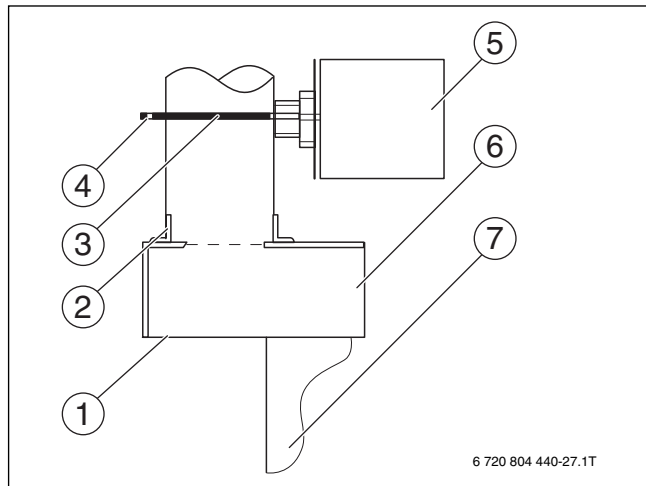

Fig. 27 Checking vent damper

- [1] Open draft hood
- [2] Vent connection
- [3] Vent damper
- [4] Damper blade position indicator
- [5] Vent damper motor
- [6] Flue gas collector
- [7] Boiler

Checking aquastat

Check the function of the maximum aquastat to make sure that it switches the boiler off as soon as the boiler water temperature set at the aquastat is reached. Record the result in the start-up protocol.

- ▶ Set aquastat to its desired setting.
- ▶ Replace front door and close.

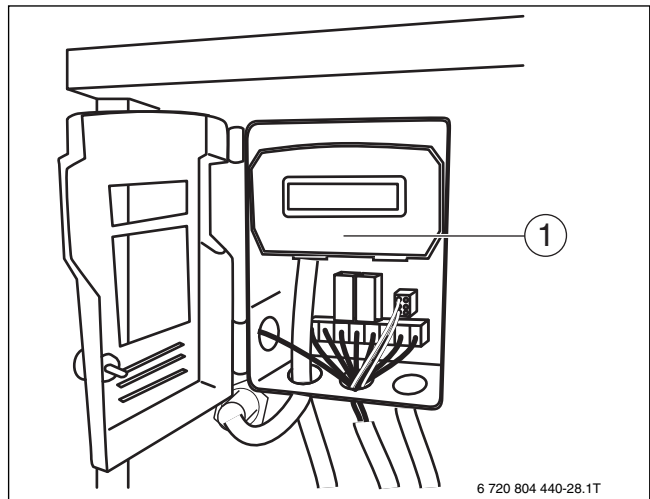

Fig. 28 Checking temperature control

- [1] Adjustment keypad

13 Start-up protocol

Please check off all startup steps and record measurements in the appropriate tables.

Start-up procedure		Remarks or measured values	
1.	Type of gas	Natural gas <input type="checkbox"/>	LP <input type="checkbox"/>
2.	Has the leak test been completed?	<input type="checkbox"/>	
3.	Check combustion air, inlet and outlet openings and flue gas connection	<input type="checkbox"/>	
4.	Check the equipment (correct orifices? See below) and convert gas type if necessary	<input type="checkbox"/>	
5.	Fill boiler with water and bleed complete heating system	<input type="checkbox"/>	
6.	Measure gas supply pressure (flow pressure)	----- inches W. C.	
7.	Measure manifold pressure and adjust if necessary	----- inches W. C.	
8.	Check pilot and main burner flame	<input type="checkbox"/>	
9.	Leak check in operating status	<input type="checkbox"/>	
10.	Correct functioning of the venting system	<input type="checkbox"/>	
11.	Check maximum temperature control setting	<input type="checkbox"/>	
12.	Install front boiler door	<input type="checkbox"/>	
13.	Inform operator, hand over technical documentation	<input type="checkbox"/>	
14.	Operator:	Signature: _____	

Table 11 Start-up protocol



Inform the customer of the correct fuel and enter it in the table (operating manual of boiler).

Informing the owner/operator and handing over technical documentation

Inform the owner/operator of the operation of the complete heating system and the operating instructions for the boiler. The heating contractor shall instruct and demonstrate the start-up and shut-down procedure of the boiler to the owner/operator. Please instruct the owner/operator how to proceed in case of a fire. Sign the protocol on this page with the owner and hand over the technical documentation.

14 Taking the heating system out of operation

14.1 Normal system shut-down

- ▶ Turn ON/OFF switch (emergency shutoff switch) to OFF position. This shuts off power to the boiler and all of its components (e.g. burner, temperature controller).
- ▶ Turn ON/OFF knob on gas valve clockwise to OFF position.



NOTICE: System damage due to freezing.
The heating system can freeze up in cold weather if it is shut down.

- ▶ Leave the heating system switched ON constantly as much as possible.
- ▶ Protect the heating system from freezing by draining the boiler and water pipes at the lowest point.

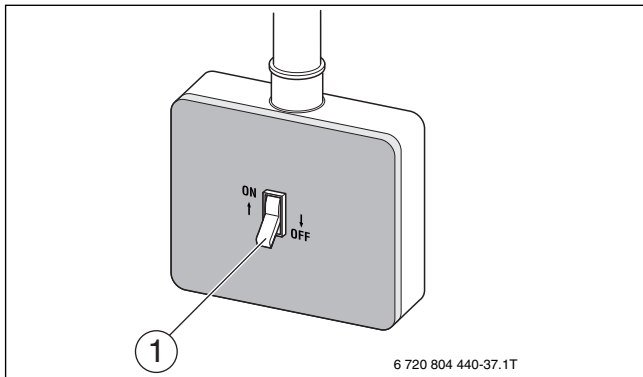

Fig. 29 Emergency shut-down

[1] ON/OFF switch (Emergency shutoff switch)

14.2 Emergency shut-down procedures

Inform the owner and operator of the procedure in case of emergency:

- ▶ Never put yourself at risk. Your own safety must always take priority.
- ▶ Shut off main gas supply.
- ▶ Shut down the heating system using the boiler emergency shutoff switch or the corresponding circuit-breaker.

15 Boiler inspection and maintenance

15.1 Why is regular maintenance important?

Heating systems require regular maintenance for the following reasons:

- to maintain high efficiency operation and to operate the heating system economically (low fuel consumption),
- to sustain safe operation,
- to maintain combustion at an environmentally responsible level.
- to ensure trouble-free operation and long life.

All maintenance work must be carried out by a qualified boiler technician. When replacing components use only parts approved by Buderus. Maintenance is required once a year. Record the results of the inspection in the protocol on page 25.



Spare parts can be ordered from the spare parts catalog.

15.2 Testing the flue system, including combustion air, air inlets and Ventilation openings

Check the venting system, including the combustion air, inlet and outlet openings. All faults must be repaired immediately. Make sure that the combustion air feed and the inlets and outlets are not blocked at any point.

15.3 Inspection of the boiler and burner

- ▶ Visually check the boiler and burner for external dirt.
- ▶ If dirt is found, clean boiler and burner.

15.4 Preparing boiler for cleaning

- ▶ Take the boiler out of operation (→ chapter 14).



WARNING: Risk to life from electric shock.

- ▶ Before opening a unit: disconnect electrical power and lock to prevent accidental reactivation.

- ▶ Open and remove front door of boiler (→ figure 19, page 15).



WARNING: Risk to life from explosion of flammable gases.

- ▶ Never work on gas lines unless you are licensed for this type of work

- ▶ Turn gas valve ON/OFF knob clockwise to OFF position. Do not use force.



WARNING: Risk to life from explosion of flammable gases.

- ▶ Wait five (5) minutes until all gas residues have dissipated. Check whether there is any smell of gas, including at floor level. If there is a gas odor, shut off main gas valve immediately. Turn off power to the heating system and call your customer service technician or gas company.

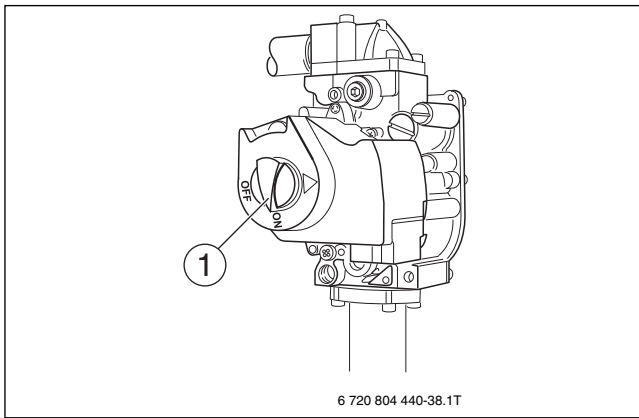

Fig. 30 Gas valve

- [1] ON/OFF knob (shown in ON position)

15.5 Cleaning the boiler

The boiler can be cleaned with brushes and/or by wet cleaning. Cleaning tools are available as accessories.

Inspecting the ignition burner

- ▶ Observe the ignition burner through the sight glass window (→ figure 31).

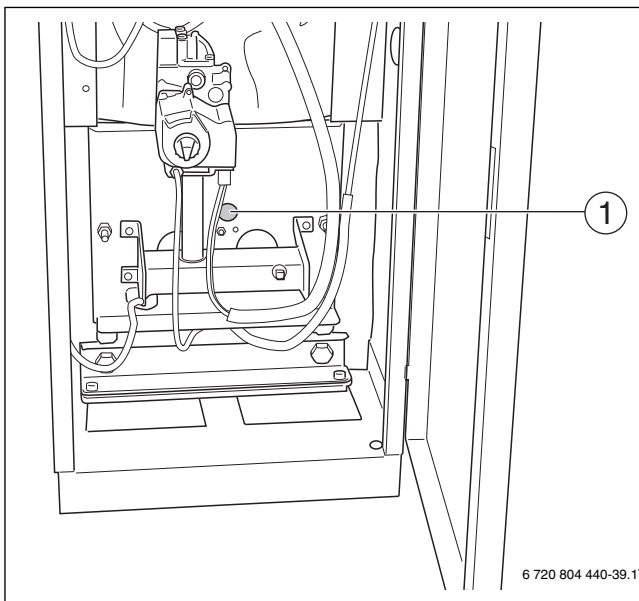

Fig. 31 GC 144 II

- [1] Sight glass

- ▶ The flame must rise over the sensor by $\frac{1}{2}$ " to $1\frac{1}{2}$ ".
- ▶ The pilot ignition gas pressure must be adjusted if the flame is too small or too large.



The adjustment screw is located behind a safety screw on the gas valve (→ figure 33).

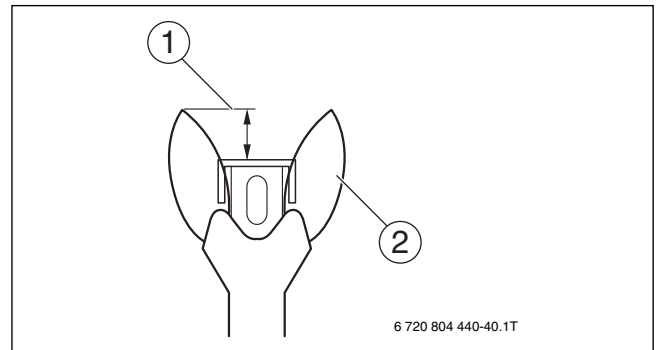

Fig. 32 Correct ignition flame setting

- [1] Flame rises $\frac{1}{2}$ " to $1\frac{1}{2}$ " above sensor
[2] Ignition flame

- ▶ Remove the safety screw on the adjustment screw for the igniter (→ figure 24, page 17). Turn the inner adjustment screw clockwise to reduce the size of the ignition flame, and counterclockwise to increase it.
- ▶ After completed adjustment replace the safety screw (→ figure 24, page 17).
- ▶ If the flame is too small, the pilot orifice needs cleaning (→ figure 39, page 23). If the igniter flame is acceptable, start cleaning.



Be careful not to damage the pilot orifice during installation and cleaning.

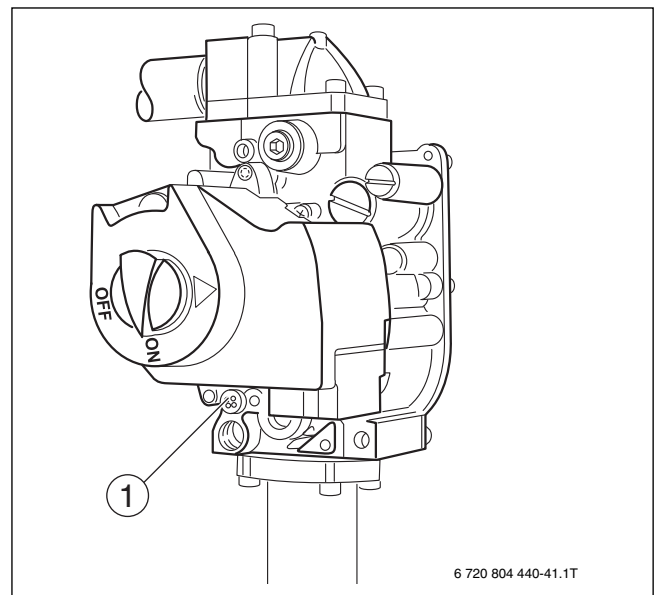

Fig. 33 Gas valve

- [1] Safety screw on igniter adjustment screw

15.5.1 Cleaning the boiler with brushes

Burner removal



WARNING: Risk to life from electric shock.

- ▶ Before opening a unit: disconnect electrical power and lock to prevent accidental reactivation.
- ▶ If cables are connected incorrectly the system may not operate correctly with possibly dangerous consequences.
- ▶ After maintenance test the heating system for proper function.

- ▶ Before opening a unit: disconnect electrical power and lock to prevent accidental reactivation.
- ▶ Close main gas shut-off.
- ▶ Secure gas manifold with wire or cord.
- ▶ Remove igniter cable from ignition module (→ figure 34, page 22).
- ▶ Disconnect cable connector from bottom of gas valve (→ figure 34, page 22).
- ▶ Label cables to the flame roll-out switch, then remove cable (→ figure 34, page 22).

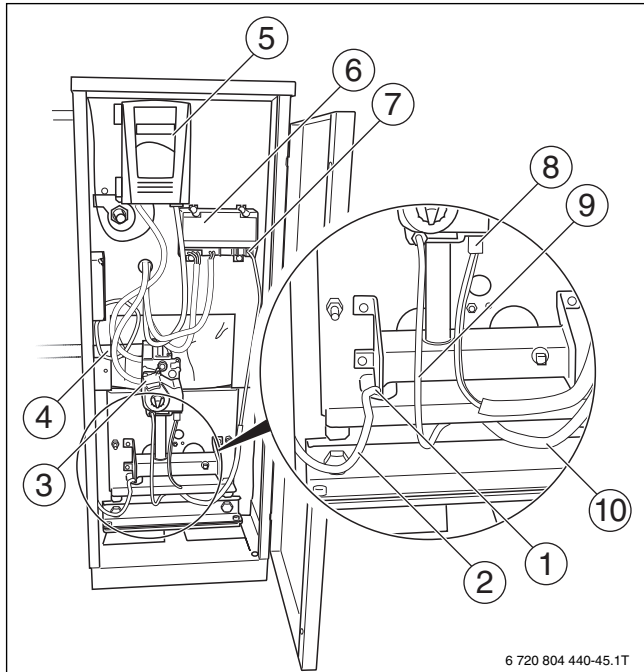

Fig. 34 Front view GC 144 II

- [1] Flame roll-out switch
- [2] Flame roll-out switch cable
- [3] Gas valve
- [4] Gas supply pipe
- [5] Boiler temperature controller
- [6] Ignition module
- [7] Igniter cable
- [8] Gas valve cable connector
- [9] Pilot line
- [10] Igniter cable

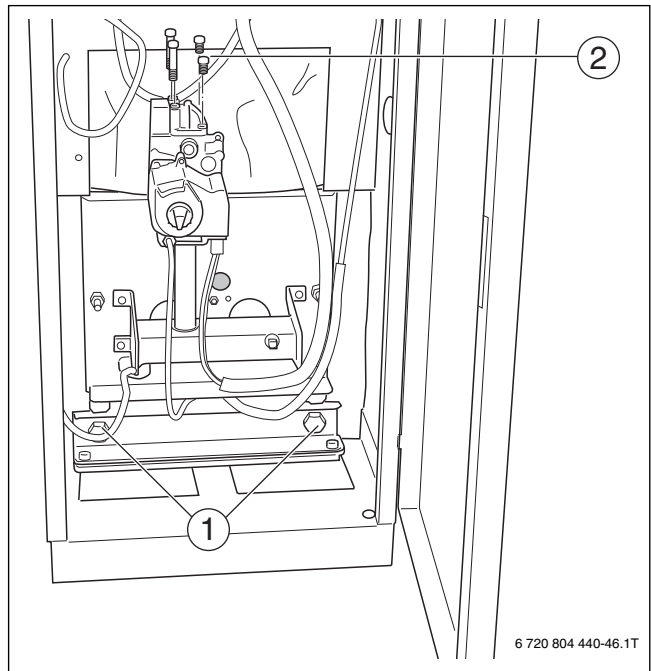

Fig. 35 Removing burner

- [1] Screw nuts (two)
- [2] Screws on gas manifold on top of gas valve (four)
- ▶ Remove four (4) screws from gas manifold on top of gas valve.
- ▶ Remove two (2) screw nuts on burner tray and take out the tray.

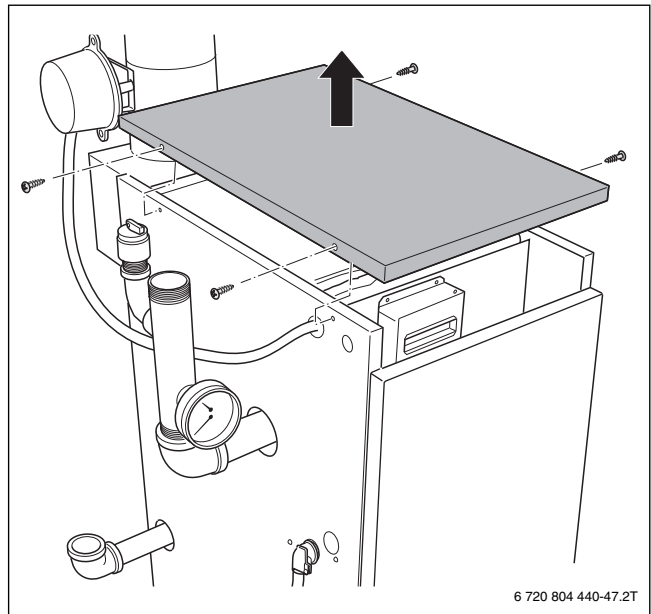

Fig. 36 Remove top cover

- ▶ Remove 4 screws on sides of the top cover and lift off.
- ▶ Remove top boiler insulation.
- ▶ Unscrew cleaning cover from the venting manifold.
- ▶ Cover control with foil to prevent entry of metal dust into the control.
- ▶ Use boiler brush to clean out flue gas passages.
- ▶ Clean combustion chamber and bottom insulation.
- ▶ Replace cleaning cover, install screws, and replace insulation.

15.5.2 Wet cleaning (chemical cleaning)

For wet cleaning use a suitable cleaning agent depending on the degree of build-up of dirt (soot or scale).

Use the same procedure as described for cleaning with brushes (→ chapter 15.5.1, page 22).



Observe the directions for use of the cleaning agent. In some cases you may need use a different procedure from that described here.

- ▶ Cover control with foil to prevent entry of spray into the control.
- ▶ Ventilate boiler room well during cleaning.
- ▶ Spray flue gas vents evenly with the cleaning agent.
- ▶ Replace and install the burner in reverse order of removal and disassembly.
- ▶ Place the heating system in operation.
- ▶ Heat the boiler water to a temperature of at least 122°F.
- ▶ Take the boiler out of operation.
- ▶ Allow boiler to cool.
- ▶ Remove burner.
- ▶ Brush out flue gas passages.
- ▶ Clean combustion chamber and bottom insulation.
- ▶ Continue to ventilate boiler room well.
- ▶ Install burner.
- ▶ Reattach boiler jacket.

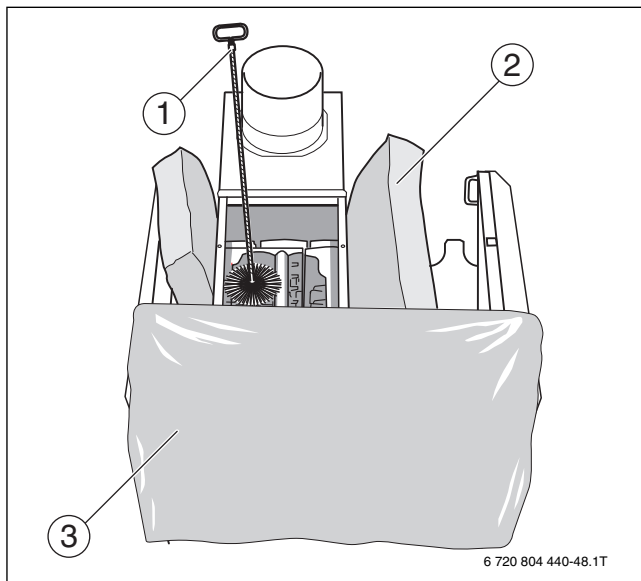

Fig. 37 Clean out the gas passages

- [1] Cleaning brush
- [2] Insulation
- [3] Foil

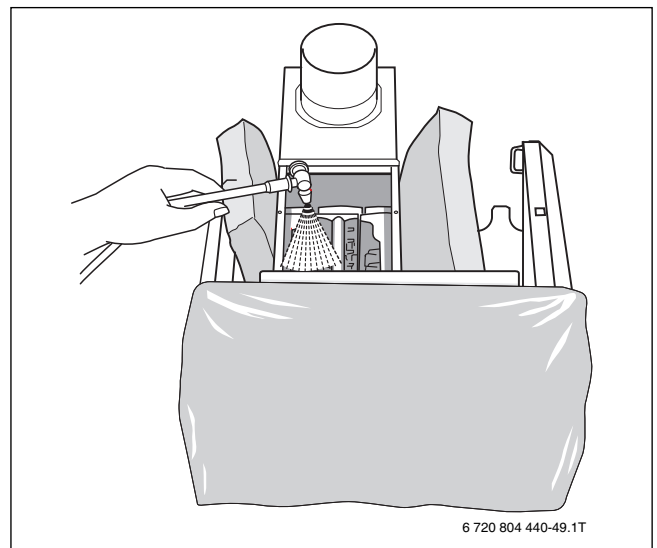

Fig. 38 Wet cleaning boiler

15.6 Cleaning the burner

- ▶ Remove burner (→ chapter 15.5.1, page 22).
- ▶ Check burner rods for dirt. If necessary, clean burner as described below.
- ▶ Unscrew ignition burner unit from burner.
- ▶ Disconnect ignition gas line from ignition burner unit.
- ▶ Remove ignition gas jet and blow out.
- ▶ Immerse burner rods in water with cleaning agent and brush off.



Be careful not to damage the pilot orifice during installation and cleaning. Ensure that the insulation on the burner shield, the gas valve, and the controls do not get wet.

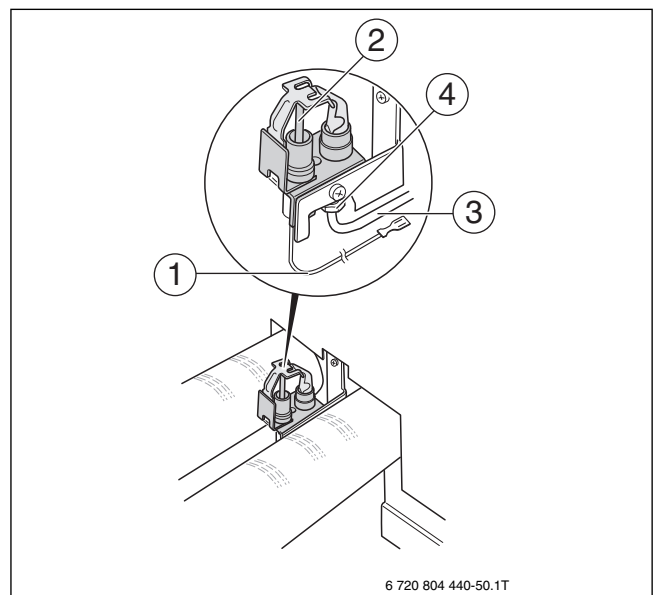

Fig. 39 Ignition burner

- [1] Ignition cable
- [2] Ignition electrode
- [3] Ignition gas line
- [4] Ignition gas line screw

- ▶ Rinse out burner rods with a water jet; hold burner so water enters all slots of the burner rods and drains back out.

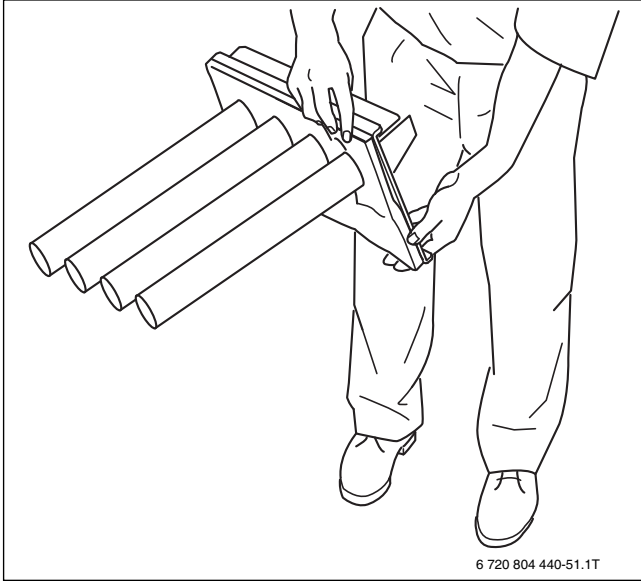

Fig. 40 Moving burner back and forth to remove water

- ▶ Remove remaining water by moving the burner back and forth.
- ▶ Verify that the slots of the burner rods are clear. Remove all water and dirt residue from the slots. If any slots are damaged the burner must be replaced.
- ▶ Check igniter for damage and signs of corrosion. Replace if necessary.

Inspection of the pilot flame

- ▶ Repeat all steps in the paragraph „Inspecting the ignition burner“.



Be careful not to damage the pilot orifice during installation and cleaning.

- ▶ Assemble and install the burner in reverse order of removal and disassembly. (→ paragraph „Burner removal“, page 22).

Performing final checks



WARNING: Risk of fire from flammable material or liquids.

- ▶ The area around the boiler must be free from flammable substances, gasoline or any other flammable or corrosive vapors and liquids.
- ▶ Maintain a minimum distance of 15 inches around the boiler.



WARNING: Risk to life from explosion of flammable gases.

- ▶ After maintenance work leaks can occur in pipes and threaded fastenings.
- ▶ Make a thorough check for leaks.
- ▶ Use only approved leak testing agents to search for leaks.

- ▶ Place boiler in operation as directed in „Placing the heating system in operation“ (→ chapter 11, page 14).

- ▶ Follow instructions in „Final start-up procedures“.
- ▶ Test low water alarm.
- ▶ Check area around boiler for hazards.

Complete the maintenance protocol to confirm that all maintenance work has been conducted. Sign the maintenance protocol and discuss it with the owner of the heating system.

15.7 Maintenance protocol

Please check off the maintenance work as it is completed and record the measured values.

Follow the instructions on the following pages.

Maintenance work		Page	Date:	Date:
1.	Inspection of the flue system including combustion air, inlet and outlet openings	page 20	<input type="checkbox"/>	<input type="checkbox"/>
2.	Gas manifold pressure	page 20 page 11	<input type="checkbox"/>	<input type="checkbox"/>
3.	Inspection of burner	page 20	<input type="checkbox"/>	<input type="checkbox"/>
4.	Cleaning of boiler	page 21	<input type="checkbox"/>	<input type="checkbox"/>
5.	Cleaning of burner	page 23	<input type="checkbox"/>	<input type="checkbox"/>
6.	Measuring gas supply pressure	page 16	-----inches W. C.	-----inches W. C.
7.	Measuring orifice pressure	page 16	-----inches W. C.	-----inches W. C.
8.	Checking for leaks in operating condition	page 14	<input type="checkbox"/>	<input type="checkbox"/>
9.	Checking pilot burner flame	page 21 ff.	<input type="checkbox"/>	<input type="checkbox"/>
10.	Checking main burner flame	page 16	<input type="checkbox"/>	<input type="checkbox"/>
11.	Check the vent damper	page 18		
12.	Check high temperature limit control	page 18	<input type="checkbox"/>	<input type="checkbox"/>
13.	Check the area around the boiler for flammable materials, gasoline or corrosive liquids.	page 15	<input type="checkbox"/>	<input type="checkbox"/>
14.	Confirm maintenance		<input type="checkbox"/>	<input type="checkbox"/>
	Confirmation of correct maintenance (company stamp, signature)			

Table 12 Maintenance protocol

15.8 Troubleshooting the GC 144 II

Equipment required: Wiring diagrams (→ chapter 17, page 30) and voltage detectors for 120 VAC and 24 VAC.

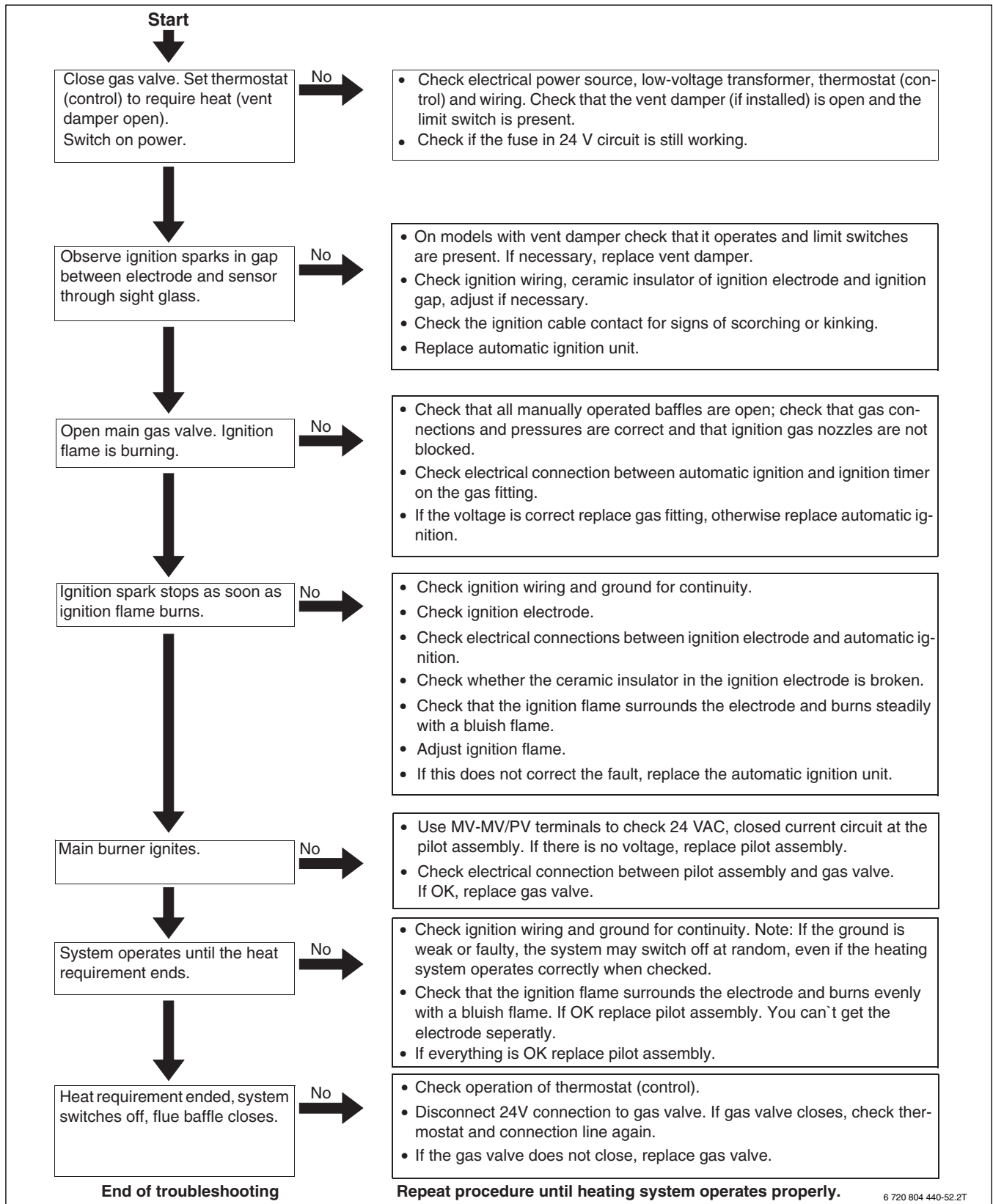
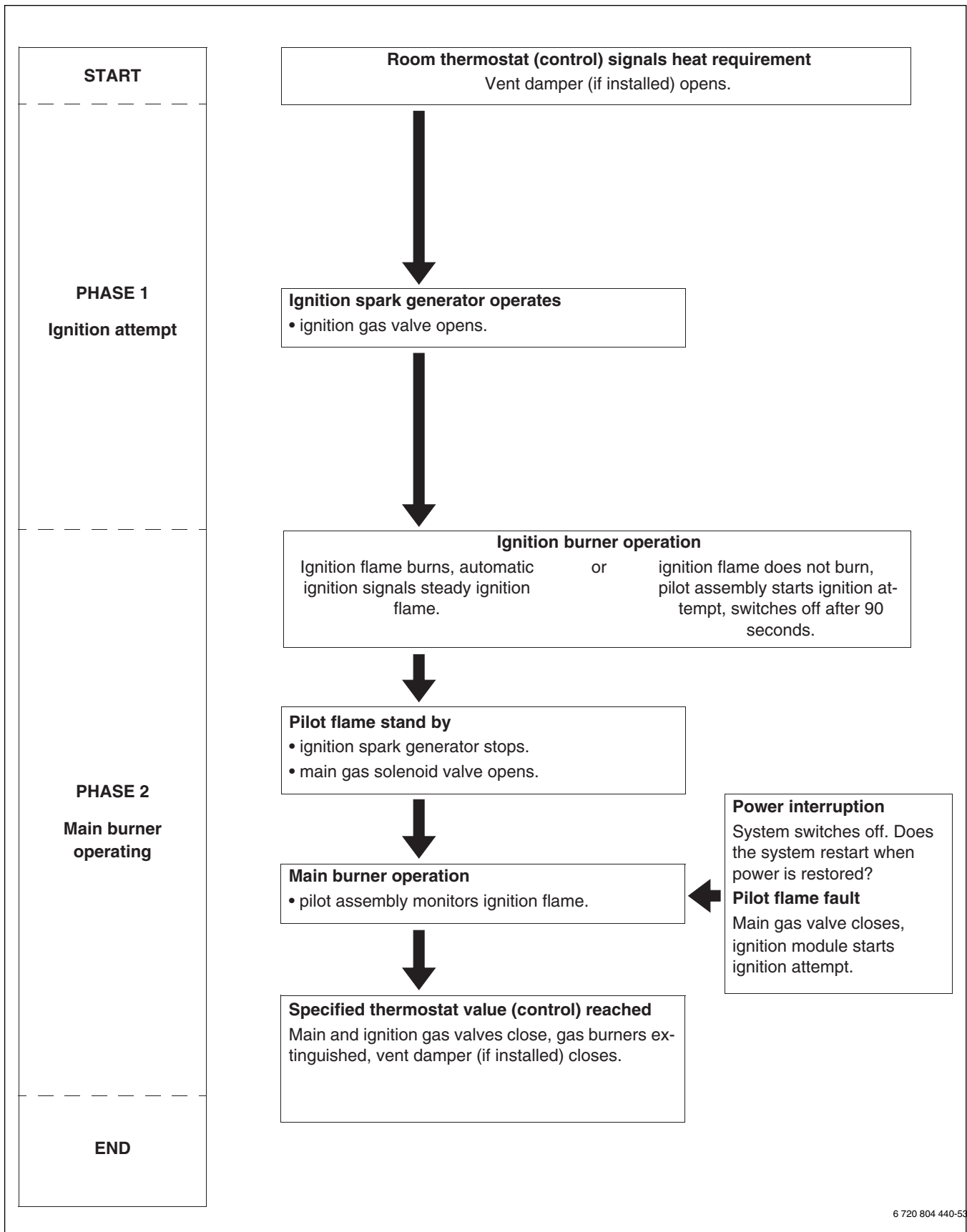

Fig. 41 Troubleshooting the GC 144 II



6 720 804 440-53

Fig. 42 Troubleshooting the GC 144 II

16 Technical specifications

Main gas orifice identification and manifold pressure for Natural gas

Boiler size	Number of orifices	Main gas orifice identification for elevations from [feet] 0–8500 ft ¹⁾	[in ft ³ /h]	[inch W.C.]
18/3	2	285	68.8	3.5
25/4	3	275	95.8	3.5
32/5	4	270	123.3	3.5

Table 14 Main gas orifice identification and manifold pressure for Natural gas at 60°F / 30 inch HG.
These values are only valid in the U.S.A. and only for elevations from 0 – 8500 ft.

1) installation attitude

Main gas orifice identification and manifold pressure for LP

Boiler size	Number of orifices	Main gas orifice identification for elevations from [feet] 0–8500 ft ¹⁾	[in ft ³ /h]	[inch W.C.]
18/3	2	180	29.6	8.8
25/4	3	175	41.2	8.6
32/5	4	170	53	8.7

Table 15 Main gas orifice identification and manifold pressure for Natural gas at 60°F / 30 inch HG.
These values are only valid in the U.S.A. and only for elevations from 0 – 8500 ft.

1) installation attitude



Only convert the boiler from natural gas to LP by consulting the conversion instructions



If the installation is over 8500 feet above sea level, please contact Buderus for another product option as the GC 144 II is not approved above 8500 feet operation. Do not attempt to alter this boiler without consulting Buderus.

17 Electrical circuit diagrams

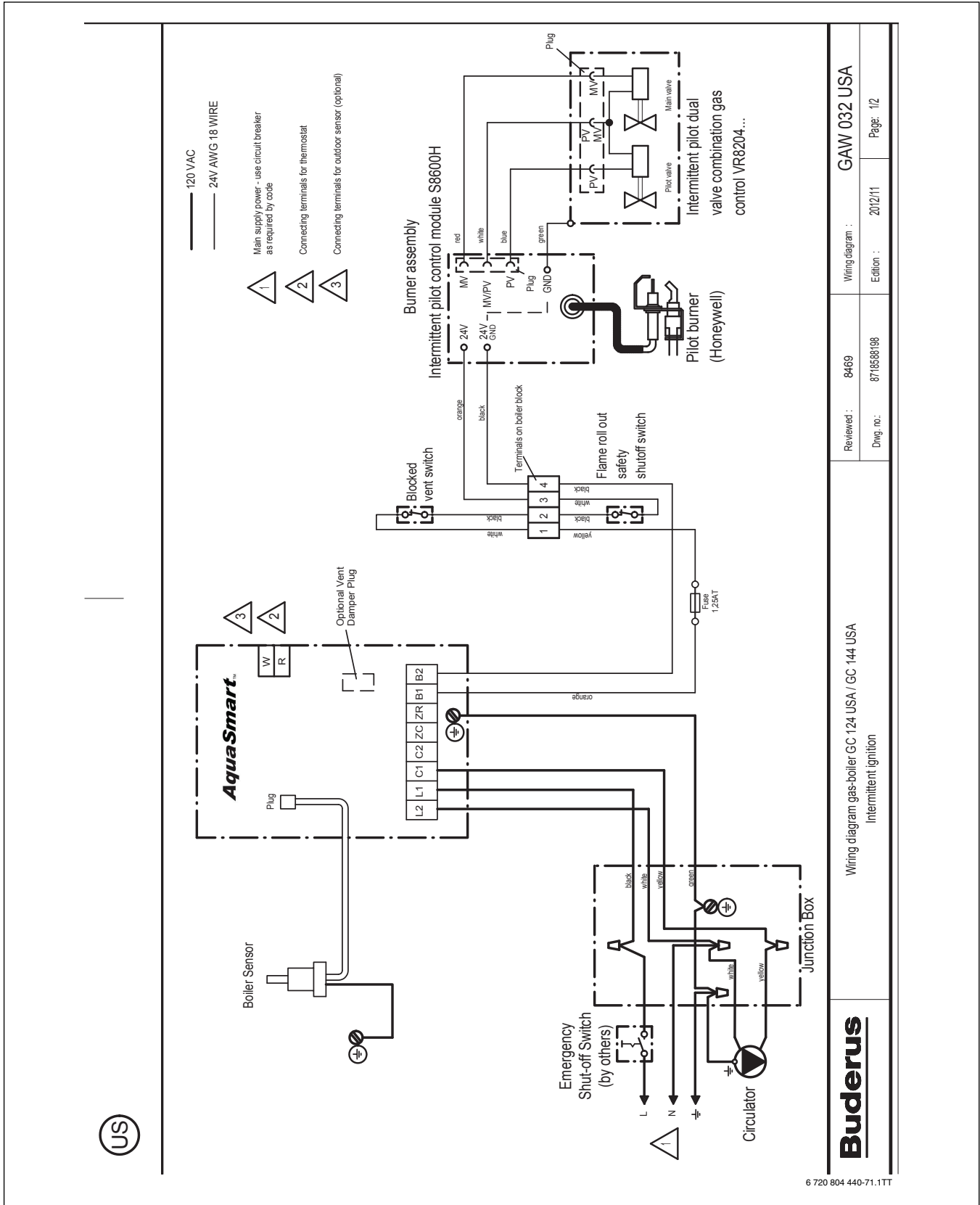

Wiring diagram gas-boiler GC 124 USA / GC 144 USA Intermittent ignition		Reviewed : 8469	Wiring diagram : GAW 032 USA
Dwg. no. : 8718588198		Edition : 2012/11	Page: 1/2

6 720 804 440-71.1TT

Fig. 43 Wiring Diagram– GC 144 II

United States and Canada

Bosch Thermotechnology Corp.
50 Wentworth Avenue
Londonderry, NH 03053
Tel. 603-552-1100
Fax 603-965-7581
www.buderus.us
U.S.A.

Products manufactured by
Bosch Thermotechnik GmbH
Sophienstrasse 30-32
D-35576 Wetzlar
www.buderus.com

Bosch Thermotechnology Corp. reserves the right
to make changes without notice due to continuing
engineering and technological advances.

Buderus