

# SUBMITTAL INFORMATION

## Angle Key Yoke Valves - (AV94-32xW-Q-NL style)

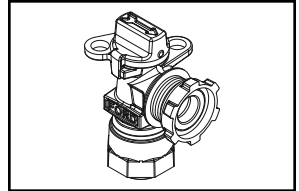

### QUICK JOINT FOR COPPER OR PLASTIC TUBING (CTS) INLET BY METER YOKE NOSE OUTLET

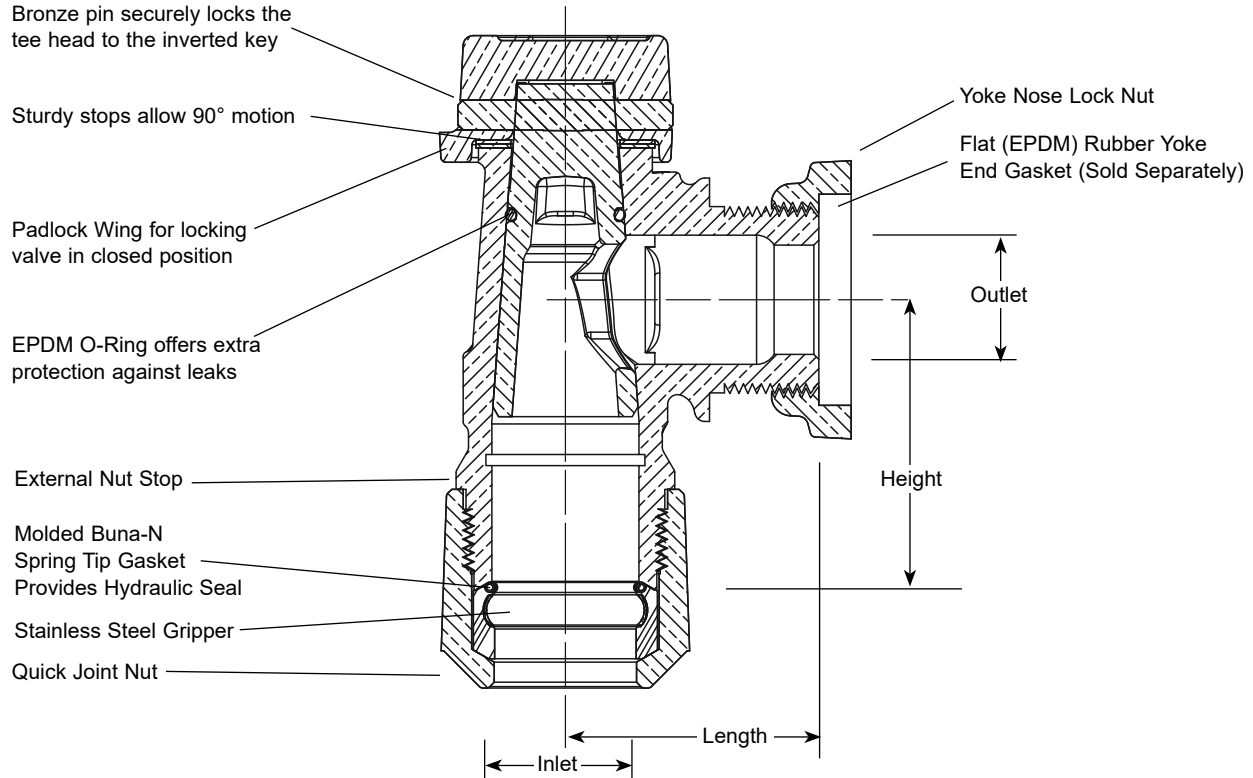

| VALVE SIZE | INLET SIZE | OUTLET SIZE      | LENGTH   | HEIGHT   | APPROX. WT. LBS | CATALOG NUMBER | ✓ SUBMITTED ITEM(S) |
|------------|------------|------------------|----------|----------|-----------------|----------------|---------------------|
| 3/4"       | 3/4"       | 5/8"x3/4" & 3/4" | 1-19/32" | 1-13/16" | 1.5             | AV94-323W-Q-NL |                     |
| 3/4"       | 1"         | 5/8"x3/4" & 3/4" | 1-57/64" | 1-49/64" | 1.7             | AV94-324W-Q-NL |                     |

**Note:** Ford recommends using insert stiffeners with plastic pipe or tubing.

### FEATURES

- All brass that comes in contact with potable water conforms to AWWA Standard C800 (ASTM B584, UNS C89833)
- The product has the letters "NL" cast into the main body for lead-free identification
- Certified to NSF/ANSI Standard 61 and NSF/ANSI Standard 372 where applicable
- Brass components that do not come in contact with potable water conform to AWWA Standard C800 (ASTM B62 and ASTM B584, UNS C83600, 85-5-5-5)
- Meets 100 PSI working pressure requirement of AWWA Standard C800
- Padlock wing for locking the valve in a closed position
- EPDM rubber yoke nose gasket sold separately: GT-112 (5/8"), GT-118 (3/4") and GT-123 (1")
- **Optional Drain/Test Valve** is available. Add "D" to the catalog number Ex. AV94-323WD-NL

The Ford Meter Box Company considers the information in this submittal form to be correct at the time of publication. Item and option availability, including specifications, are subject to change without notice. Please verify that your product information is current.



**The Ford Meter Box Company, Inc.**  
 P.O. Box 443, Wabash, Indiana U.S.A. 46992-0443  
 Phone: 260-563-3171 / Fax: 800-826-3487  
 Overseas Fax: 260-563-0167  
 www.fordmeterbox.com

02/27/17

Submitted By: