

**WALCHEM**

IWAKI America Inc.

EW-F & EK Series Metering Pumps

# EW-F & EK Series Electronic Metering Pump Instruction Manual

Five Boynton Road Hopping Brook Park Holliston, MA 01746 USA

TEL: 508-429-1110 FAX: 508-429-7433 WEB: [www.walchem.com](http://www.walchem.com)

## Notice

© 2014 WALCHEM, Iwaki America Inc. (hereinafter "Walchem")  
Five Boynton Road, Holliston, MA 01746 USA  
tel (508) 429-1110 fax (508) 429-7433  
All Rights Reserved  
Printed in USA

## Proprietary Material

*The information and descriptions contained herein are the property of WALCHEM. Such information and descriptions may not be copied or reproduced by any means, or disseminated or distributed without the express prior written permission of WALCHEM.*

*This document is for information purposes only and is subject to change without notice.*

## Statement of Limited Warranty

*WALCHEM warrants equipment of its manufacture and bearing its identification to be free from defects in workmanship and material for a period of two years from date of delivery from the factory or authorized distributor under normal use and service and otherwise when such equipment is used in accordance with instructions furnished by WALCHEM and for the purposes disclosed in writing at the time purchased, if any. WALCHEM's liability under this warranty shall be limited to replacement or repair, F.O.B. Holliston, MA U.S.A. of any defective equipment or part which, having been returned to WALCHEM, transportation charges prepaid, has been inspected and determined by WALCHEM to be defective.*

***THIS WARRANTY IS IN LIEU OF ANY OTHER WARRANTY, EITHER EXPRESS OR IMPLIED, AS TO DESCRIPTION, QUALITY, MERCHANT-ABILITY, FITNESS FOR ANY PARTICULAR PURPOSE OR USE, OR ANY OTHER MATTER.***

*P/N E00118.Q  
Nov 2014*

# TABLE OF CONTENTS

Thank you for choosing a Walchem E-Class metering pump. This instruction manual deals with the correct installation, operation, maintenance and troubleshooting procedures for the EW and EK model metering pumps. Please read through it carefully to ensure the optimum performance, safety and service of your pump.

<b>1.0</b>	<b>INTRODUCTION</b> .....	<b>1</b>
1.1	Safety and Caution Notes.....	1
1.2	Principle of Operation.....	1
1.3	Model Code.....	2
1.4	Specifications.....	3
1.5	Dimensions.....	4
<b>2.0</b>	<b>INSTALLATION</b> .....	<b>7</b>
2.1	Unpacking.....	7
2.2	Location.....	7
2.3	Supply Tubing.....	8
2.4	Discharge Tubing.....	9
2.5	Installing Injection/BackPressure Valve.....	10
2.6	Interlocking Pump.....	10
2.7	Electrical.....	11
<b>3.0</b>	<b>OPERATION</b> .....	<b>11</b>
3.1	Pump Operation & Programming.....	11
3.2	External Inputs & Outputs.....	14
3.3	Adjustment.....	17
3.4	MultiFunction Valve Operation.....	18
3.5	Auto Air Vent Valve Operation.....	19
3.6	Priming.....	19
3.7	Calibration.....	20
3.8	AC Power Interruption.....	20
<b>4.0</b>	<b>MAINTENANCE</b> .....	<b>21</b>
4.1	Diaphragm Replacement.....	21
4.2	Valve Replacement.....	21
4.3	Tubing.....	21
<b>5.0</b>	<b>EXPLODED VIEW &amp; PARTS GUIDE</b> .....	<b>22</b>
<b>6.0</b>	<b>TROUBLESHOOTING</b> .....	<b>33</b>
<b>7.0</b>	<b>SERVICE POLICY</b> .....	<b>33</b>

## 1.0 INTRODUCTION

---

### 1.1 Safety and Caution Notes



Always wear protective clothing, eye protection and gloves before working on or near a metering pump. Follow all recommendations of the supplier of the solution being pumped. Refer to the MSDS from the solution supplier for additional precautions.

Walchem E-Class metering pumps should be installed where ambient temperatures do not exceed 122°F (50°C) or do not fall below 32°F (0°C). Pumps should always be shielded from direct exposure to the elements. Black UV resistant tubing should be used if the tubing is exposed to strong UV radiation (sunlight/lamps). The EK Series is specifically designed to withstand the elements and can be mounted directly outdoors within the temperature specifications. To protect and maintain the IP rating of the pump, the clear covers that protect the electronic controls **MUST** be left in a secured/tightened condition at all times other than during adjustment of the pump.



**WARNING Risk of electrical shock!** This pump is supplied with a grounding conductor and grounding-type attachment plug. To reduce the risk of electrical shock, be certain that it is connected only to a properly grounded, grounding type receptacle with ratings conforming to the data on the pump data plate. Prior to performing any maintenance on a pump, disconnect the pump from the electrical power source.



#### **Plumbing Precautions**

All tubing must be securely attached to the fittings prior to starting the pump (see Section 2.3). Only use Walchem tubing with your pump. Tubing should be shielded to prevent possible injury in case of rupture or damage. UV resistant tubing should be used if the tubing is exposed to UV light. Always adhere to local plumbing codes and requirements. Be sure that the installation does not constitute a cross connection. Walchem is not responsible for improper installations. Prior to performing any maintenance on a pump, depressurize the discharge tubing.

If you are pumping downhill or into little or no system pressure, a back pressure/anti-syphon device must be installed to prevent over-pumping. Contact your Walchem distributor for additional information.



#### **Solution Compatibility**

**CAUTION!** This pump has been evaluated for use with water only. The suitability of this pump for use with liquids other than water, such as acid and alkaline, is the responsibility of the user. For liquids other than water, select the best-suited liquid end material combination using a chemical compatibility chart.

### 1.2 Principle of Operation

The E-Class electronic metering pumps consist of a pump unit, a drive unit, and a control unit. The drive unit is an electromagnetic solenoid. When the solenoid coil is energized by the control unit the armature shaft moves forward due to the magnetic force of the solenoid. The shaft is attached to a PTFE faced diaphragm which is part of the pump unit. The diaphragm is forced into the pump head cavity decreasing volume and increasing pressure which forces liquid in the pump head out through the discharge check valves. When the solenoid coil is de-energized, a spring returns the armature to its starting position. This action pulls the diaphragm out of the head cavity increasing volume and decreasing pressure. Atmospheric pressure then pushes liquid from the supply tank through the suction check valves to refill the pump head.

### 1.3 Model Code

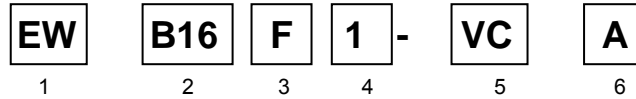

#### 1 Pump Series

**EW** IP 65 electronic metering pump with external pulse control or manual speed control (adjustable to 360 strokes per minute) and manually adjustable stroke length. (Turndown ratio 1800:1.)

**EK** IP 67 aggressive environment rated electronic metering pump with external pulse control or manual speed control (adjustable to 360 strokes per minute) and manually adjustable stroke length. (Turndown ratio 1800:1.)

#### 2 Capacity/Pressure Rating (See Section 1.4 for detailed chart.)

#### 3 Control Module

**F** For use on all EW models, features digitally adjustable speed and external pulse input control, stop & pre-stop inputs

**R** For use on all EK models, features external pulse input control and stop input.

#### 4 Voltage

**1** 115 VAC, 50/60 Hz

**2** 230 VAC, 50/60 Hz

#### 5 Liquid End (See Section 1.4 for detailed chart.)

#### 6 Options

**A** Auto Air Vent Valve is supplied in place of the manual air vent valve. Available for B11, B16, C16 and C21 sizes with -VC liquid ends only.

**M** Multifunction Valve is supplied in place of the manual air vent valve. Available for the EW and EK 11-21 sized pumps with VC, VE, VF, PC, and PE liquid ends. Not available with the AAVV feature.

**H** High Pressure pump configuration available with EW-PC and -PE liquid ends only. High Pressure pump maximum speed is 240 SPM.

## 1.4 Specifications

<b>Electrical</b>	50/60 Hz, single phase		
<b>EWB/EKB</b>	115 VAC±10%	0.8 Amp max.	20 watt avg.
	230 VAC±10%	0.4 Amp max.	20 watt avg.
<b>EWC/EKC</b>	115 VAC±10%	1.2 Amp max.	22 watt avg.
	230 VAC±10%	0.6 Amp max.	22 watt avg.

### Operating Conditions

Ambient temperature	32°F to 122°F (0°C to 50°C)
Relative humidity	To 85% (EW) / 95% (EK) non-condensing
Liquid temperature	32° to 104°F (0 to 40°C) for PVC based liquid ends
	32° to 140°F (0 to 60°C) for PP, PVDF, SS based liquid ends
	Below 32°F (0°C), pump is limited to 70% of max. pressure. Liquid cannot freeze.

### Capacity/Pressure Rating

Size	Maximum Output Capacity		Output per Stroke (mL)		Maximum Pressure <sup>1</sup>		Connection Size (in) Tubing O.D
	(Gal/hr)	(mL/min)	Min.	Max.	PSI	MPa	
<b>B11</b>	0.6	38	0.03	0.11	150	1.0	3/8
<b>B16</b>	1.0	65	0.04	0.18	105	0.7	3/8
<b>B21</b>	1.8	115	0.07	0.32	60	0.4	3/8
<b>B31</b>	3.3	210	0.12	0.58	30	0.2	1/2
<b>C16</b>	1.3	80	0.05	0.22	150	1.0	3/8
<b>C16-H</b>	0.6	40	0.03	0.17	250	1.7	3/8 (suc) x 1/4 NPT (dis)
<b>C21</b>	2.3	145	0.08	0.40	105	0.7	3/8
<b>C31</b>	4.3	270	0.15	0.75	50	0.35	1/2
<b>C36<sup>2</sup></b>	6.7	420	0.24	1.17	30	0.2	1/2

<sup>1</sup> Auto Air vent valve reduces maximum pressure approx. 35 PSI (0.2 MPa)

<sup>2</sup> Output of the EW/EKC36-TC/FC/SH is 6.3 GPH (400 ml/min)

### Adjustment Range

Stroke length adjustment range	20% to 100%
Frequency adjustment range	0 to 360 strokes per minute

### Materials of Construction

Liquid End Code	Pump Head & Fittings	Diaphragm	Valve Balls	Valve Seat	Valve Seals	Gasket	Tubing
<b>PC</b>	GFRPP	PTFE (bonded to EPDM)	CE	FKM	FKM	PTFE	PE
<b>PE</b>	GFRPP		CE	EPDM	EPDM		
<b>VC</b>	PVC		CE	FKM	FKM		
<b>VE</b>	PVC		CE	EPDM	EPDM		
<b>VF</b>	PVC		PTFE	EPDM	EPDM		
<b>TC</b>	PVDF		CE	FKM	FKM		
<b>FC</b>	PVDF		CE	PCTFE	PTFE		
<b>SH</b>	SS		HC	HC	PTFE		1/4" NPTF

CE	Alumina ceramic	PE	Polyethylene
EPDM	Ethylene propylene diene monomer	PTFE	Polytetrafluoroethylene
FKM	Fluoroelastomer	PVC	Polyvinylchloride (translucent)
GFRPP	Glass fiber reinforced polypropylene	PVDF	Polyvinylidene fluoride
HC	Hastelloy C276	SS	316 stainless steel
PCTFE	Polychlorotrifluoroethylene		

## 1.5 Dimensions

### *EW-11,16 and 21 Models with thermoplastic liquid end materials*

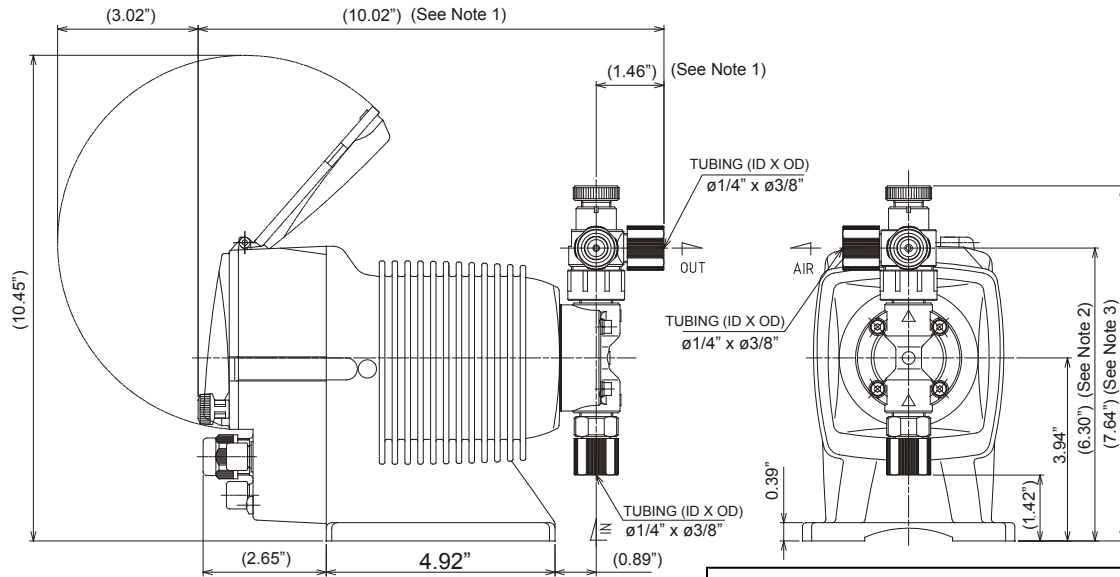

#### Notes:

1. Addition of a Multifunction valve increases overall length by 0.37". Addition of an Auto Air Vent Valve increases overall length by 1.59"
2. Addition of a Multifunction Valve increases discharge height by 0.22". No change for the Auto Air Vent Valve.
3. Addition of a Multifunction Valve increases overall liquid end height by 1.16". No change for the Auto Air Vent Valve.
4. All dimensions in inches.

### *EW-31 and 36 Models with thermoplastic liquid ends*

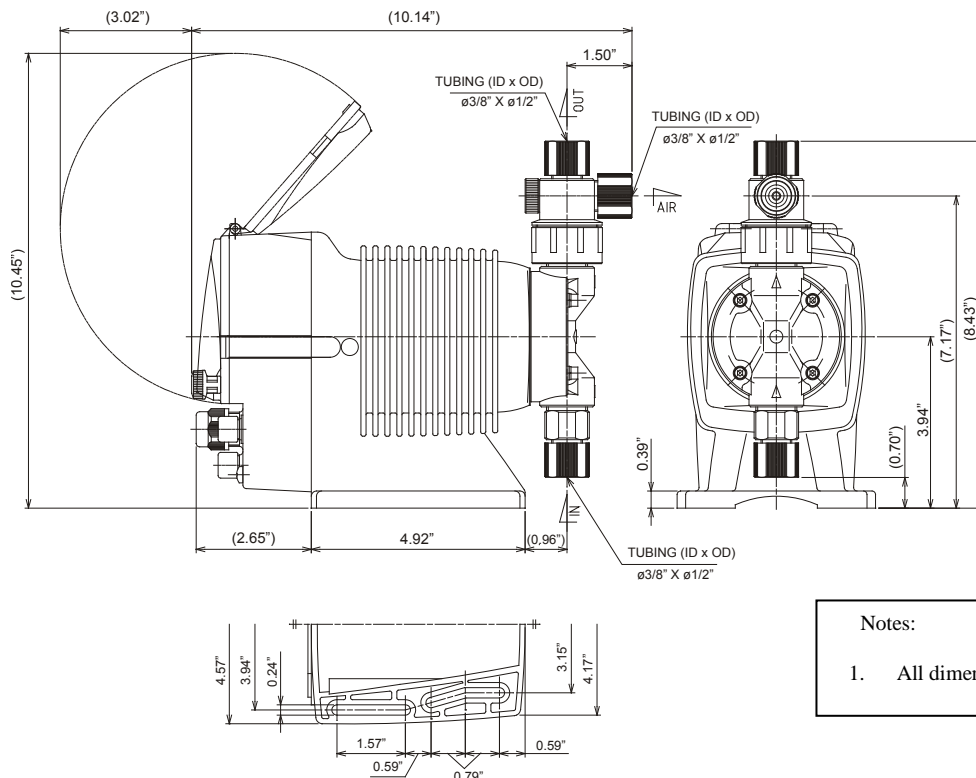

#### Notes:

1. All dimensions in inches.

**EW-SH Models (EWB11,21/C21 shown below. See notes for changes in dimensions with other sizes)**

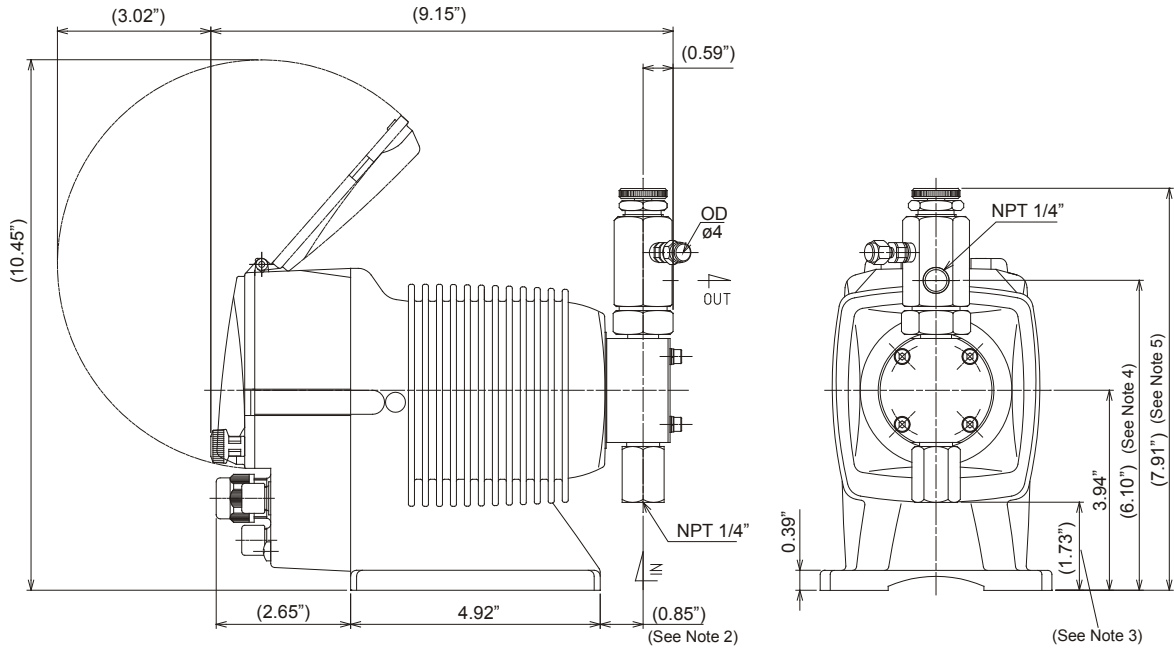

- Notes:**
1. All dimensions in inches.
  2. (0.91") for EWC31 and 36 sizes.
  3. (1.34") for EWC31 and (1.24") for EWC36.
  4. (6.57") for EWC31 and (6.67") for EWC36.
  5. (8.34") for EWC31 and (8.48") for EWC36.

**EW-HP Models**

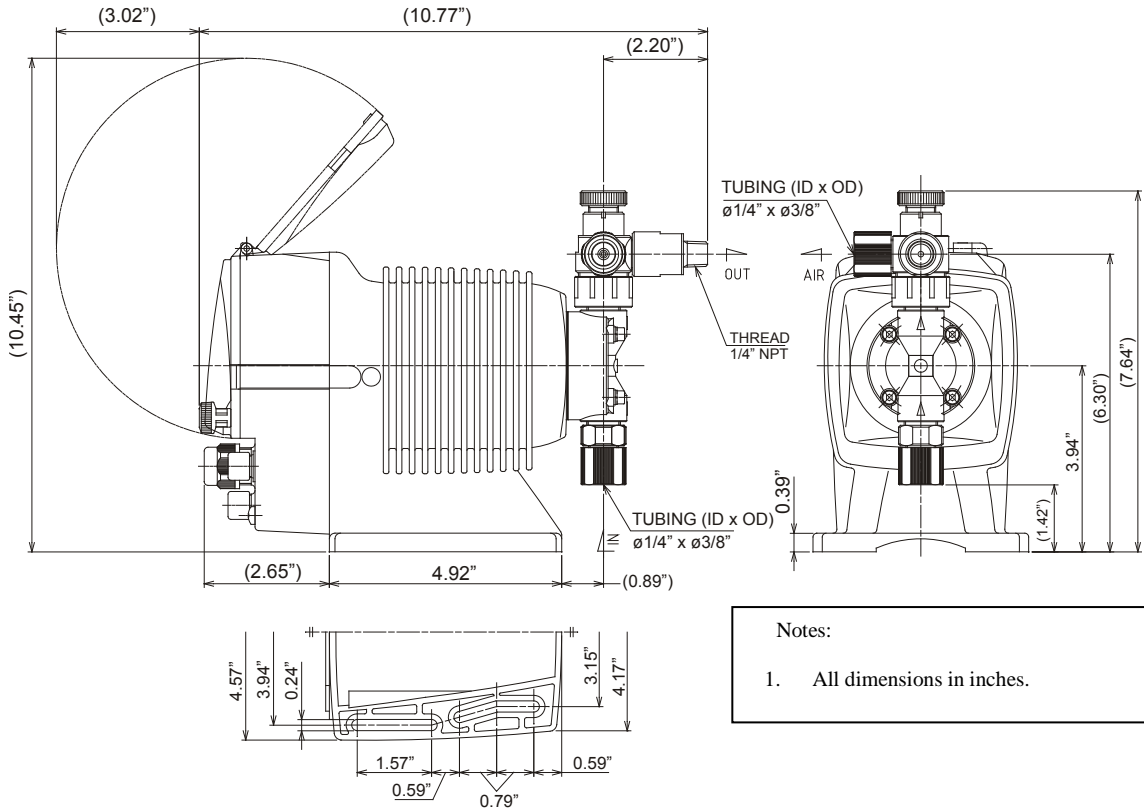

- Notes:**
1. All dimensions in inches.



**EK-11,16 and 21 Models with thermoplastic liquid end materials**

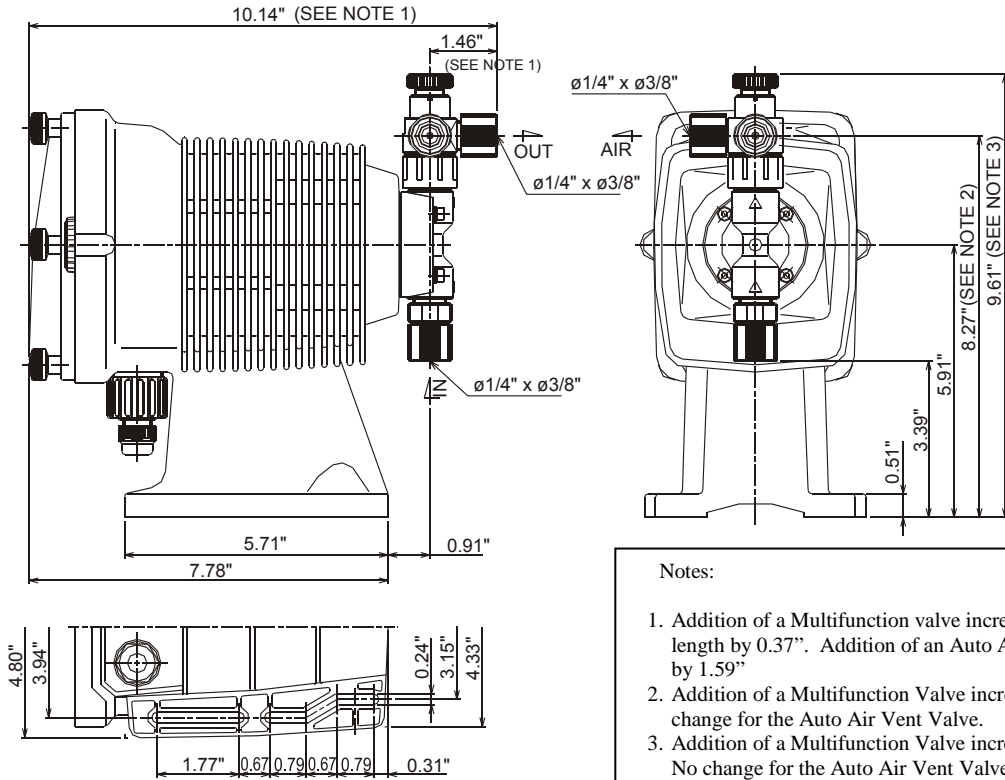

- Notes:
1. Addition of a Multifunction valve increases overall length by 0.37". Addition of an Auto Air Vent Valve increases overall length by 1.59"
  2. Addition of a Multifunction Valve increases discharge height by 0.22". No change for the Auto Air Vent Valve.
  3. Addition of a Multifunction Valve increases overall liquid end height by 1.16". No change for the Auto Air Vent Valve.
  4. All dimensions in inches.

**EK-31 and 36 Models with thermoplastic liquid ends**

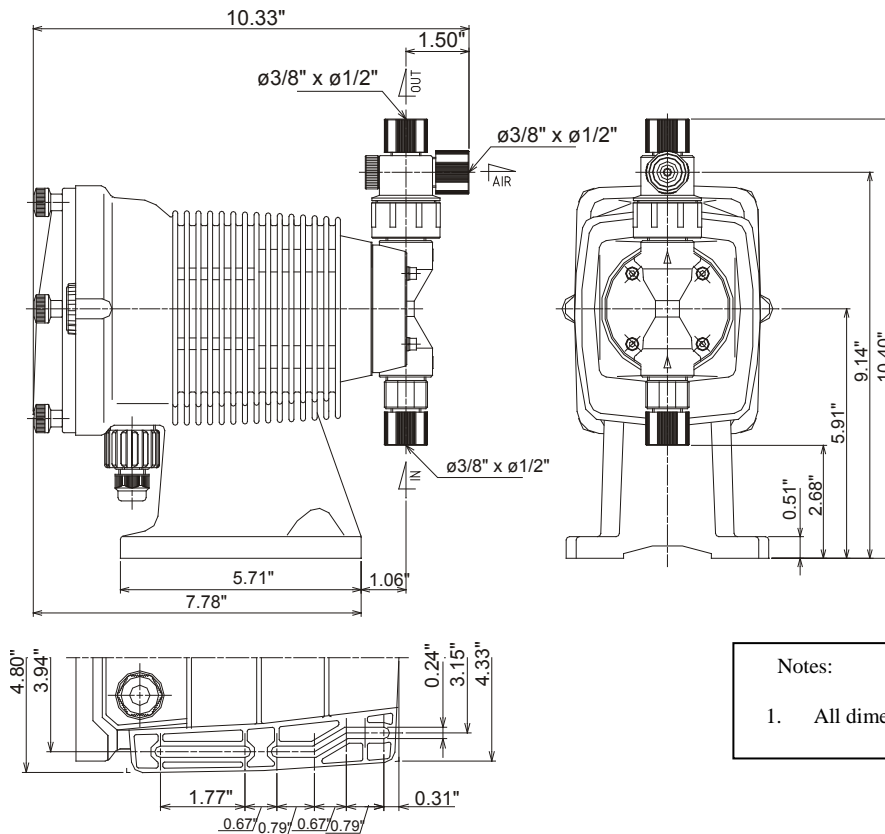

- Notes:
1. All dimensions in inches.

## 2.0 INSTALLATION

### 2.1 Unpacking

Open the shipping carton and inspect contents for damage. If any items are missing or damaged contact your local distributor.

Pumps are pre-primed with water at the factory. If the application is not compatible with water, drain and dry before use. Be sure to remove caps from fittings before attaching tubing.



**CAUTION:** Head bolts may have loosened during storage or shipment. Be sure to check and tighten to 19 lb-in torque, if necessary.

### 2.2 Location

Choose a location for the pump which is clean, dry, vibration-free, close to an electrical outlet, and allows convenient access to stroke length control, frequency control, and tubing connections. Avoid areas where ambient temperature exceeds 122°F (50°C) or falls below 32°F (0°C). Pumps should always be shielded from direct exposure to the elements. Black UV resistant tubing should be used if the tubing is exposed to strong UV radiation (sunlight/lamps).

The EK Series is specifically designed to withstand the elements and can be mounted directly outdoors within the temperature specifications.

This pump is cord connected and not intended for permanent mounting to a building structure. However, temporary mounting to stabilize the pump during operation may be necessary as long as tools are not required for the installation or removal of the pump.

Flooded suction (mounting the pump below the level of liquid in the supply tank) is strongly recommended, especially when pumping liquids that readily generate gas bubbles. Sodium hypochlorite and hydrogen peroxide are common examples of such liquids. (See Figure 1.)

If flooded suction mounting is not possible, a shelf adjacent to (but not directly above) the supply tank often works well. (See Figure 2.) The supply tank or cover can also be used if it has provisions for mounting a pump. (See Figure 3.) In any case, the total suction lift should not exceed 5 ft (1.5m).

Figure 1  
Flooded Suction  
Recommended for  
liquids that out-gas

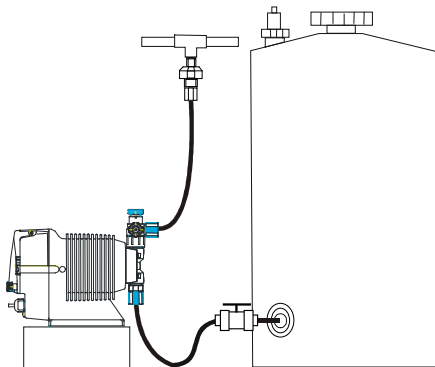

Figure 2  
Shelf Mount

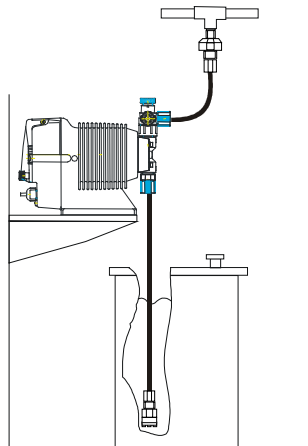
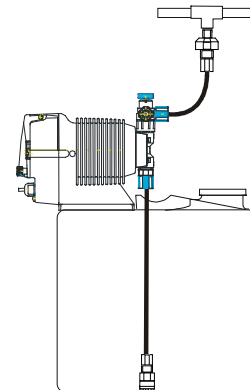

Figure 3  
Tank Mount



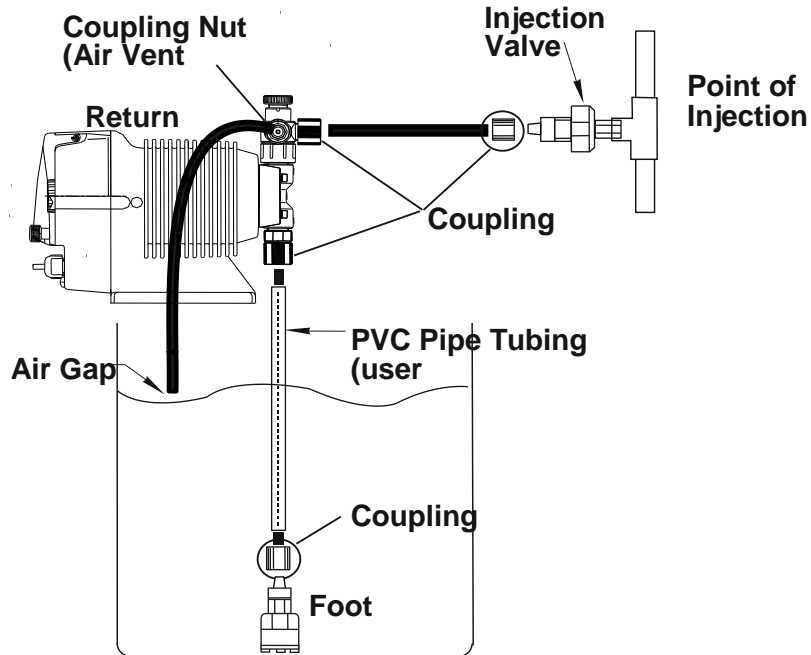

Figure 4  
Connecting Tubing

### 2.3 Supply Tubing

The supply tubing run should be as short as possible. For flooded suction mounting, install a shut-off valve with an appropriate tubing connector at the tank outlet. Cut a length of tubing from the coil supplied and install between the shut-off valve and the pump inlet fitting. For suction lift applications, slide on the ceramic weight, then install a foot valve on one end of suction tubing. Cut the tubing to a length such that the foot valve hangs vertically about 1 in (25mm) above the bottom of the tank. Avoid any loops in the tubing run that could form a vapor trap. Running the tubing through a length of pipe will help to keep tubing straight. Total vertical suction lift should be no more than 5ft. (1.5m). Reference Figure 4.

Attach tubing as shown in Figure 5. First slide the coupling nut, small end first, onto the tubing. Push the tubing over the valve housing tip *all the way to the valve housing shoulder*. (Tip: if the tubing is stiff from cold, dip the tubing end in hot tap water for a few minutes so it will slide on and flare out more easily. Push the coupling nut onto the threads. Apply some pressure on the coupling nut and tubing while tightening the nut, making sure the tubing has not backed off of the shoulder of the valve housing.



**WARNING:** *All fittings and coupling nuts should be tightened by hand only. If necessary, a small tool may be used to make it snug. DO NOT use excessive force or large wrenches.*

The coupling nut should not bottom out completely against the fitting. If this happens during connection, either the tubing has slid down the shoulder while tightening, or the tubing has been pinched. Remove the coupling nut, re-cut the tubing and re-connect.



**WARNING:** If there is any leakage around the coupling nut and it appears to have been installed correctly, **DO NOT TIGHTEN** the coupling further! Release pressure in the line, disconnect tubing, re-cut and re-connect. Tightening of misinstalled tubing may cause the tubing to pop off under pressure.

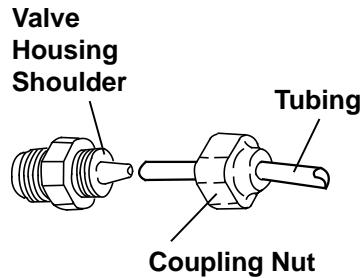

Figure 5  
Attaching the Tubing

## 2.4 Discharge Tubing

Cut a length of tubing long enough to go from the pump to the application (injection) point. Additional tubing can be ordered from your distributor. Avoid sharp turns or bends and hot surfaces. Routing tubing through rigid pipe such as PVC pipe is recommended for long runs and/or as protective shielding against corrosive chemicals. If applicable, install the injection valve in 1/2" NPT thread at the injection point (see section 2.5) and connect the discharge tubing to the injection valve.

Attach tubing as described in section 2.3 and as shown in Figures 5 and 6. Note: Some models have an air vent valve with two outlet connections. The connection marked 'OUT' is the discharge side to the application point. (Fig 6).

Attach a second length of tubing to the air vent side marked ('AIR') and route back to the chemical solution tank or drum. On the larger pumps (31 & 36 sizes), the air vent valve connections are not marked, however, the discharge side is the vertical (UP) connection and the air vent connection is on the side of the valve.

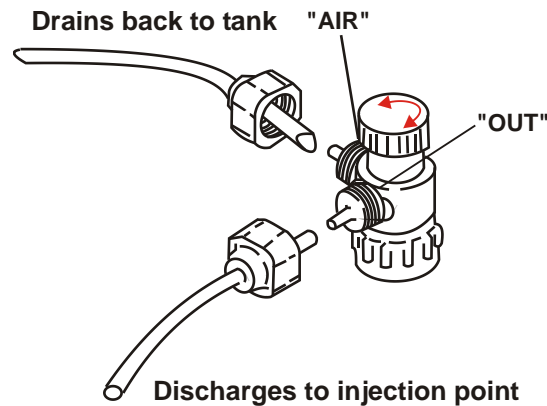

Figure 6  
Air Vent Valve Tubing

## 2.5 Installing Injection/BackPressure Valve

A fitting or tee with 3/8" or 1/2" NPTF threads and with sufficient depth will accept the injection valve assembly. If required, trim off an amount of the extension tip until it fits into the fitting or tee. (Fig. 7.)

The position of the injection/back pressure valve can be at any orientation as long as the spring is retained in the valve. **DO NOT REMOVE THE SPRING.** Be sure to check and replace the spring as needed. Attach the tubing following the same instructions in section 2.3, connecting the supply tubing.



**CAUTION:** Some chemicals may have reactions as they are injected into the main flow. For example, sulfuric acid may react with water causing excess heat. If the chemical is heavier than water, mount the injection valve as close as possible to vertical coming into the bottom of the pipe. This will keep the injection nozzle facing up and keep the heavier chemistry from draining into the pipe and causing adverse reactions within the injection valve and pipe.

In addition to preventing backflow from pressurized lines, the injection valve acts somewhat as a back pressure valve when pumping into open atmosphere type applications. However, the back pressure by the injection valve is very low and can vary. The output of the metering pumps is rated at maximum back pressure and will increase as back pressure decreases dependent on the specific installation. Additionally, the valve does **NOT** act as an anti-siphon valve. If siphoning is a possibility, or if pumping downhill into open atmosphere (open tank), a Walchem MultiFunction valve or a separate back pressure/anti-siphon valve must be installed.

Note: Siphoning can also occur at the tip of the injection valve because of the high flow rate in the main pipe flowing past the small injection nozzle (venturi effect). In this case, an anti-siphon device must be installed to avoid over feeding or siphoning of chemistry.

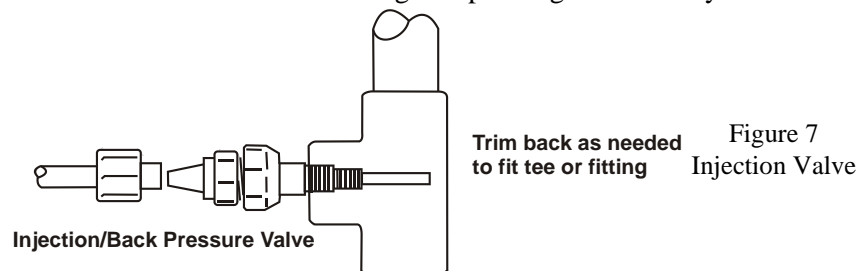

## 2.6 Interlocking Pump



**CAUTION!** Control of pump operation is critical. Operation and chemical addition during no flow situations can create hazardous situations from elevated chemical concentrations and chemical gasses trapped in the line.

Ensure that during no flow conditions such as when the well pump, main line or recirculation pump is off, and for pools/spas, in times of backwash, that the metering pump is not allowed to operate. If using a controller (pH/ORP/pool) for automated control and flow indication is tied into it, pump operation can be interlocked to the controller.

Interlocking the pump operation can also be done directly using a flow switch located in the water, main or pool/spa recirculation lines. The flow switch can be tied directly into the pumps to stop operation during no flow conditions.

## 2.7 Electrical



**WARNING Risk of electrical shock!** This pump is supplied with a grounding conductor and grounding-type attachment plug. To reduce the risk of electrical shock, be certain that it is connected only to a properly grounded, grounding type receptacle.



**CAUTION!** The electronics within the pump can be damaged by excessive surges in voltage. Do not install the pump near high-power electrical equipment that generate high surge voltages. Avoid branch circuits that also supply power to heavy or other equipment that could generate electrical interference. If necessary, install a surge suppression device (such as a varistor with a resistance greater than 2000A) or a noise reducing transformer at the pump's power connection.

## 3.0 OPERATION

---

### 3.1 Pump Operation & Programming

The EW and EK pumps have a digital display, two LED indicators and three pushbutton keys to change the pump speed and programming.

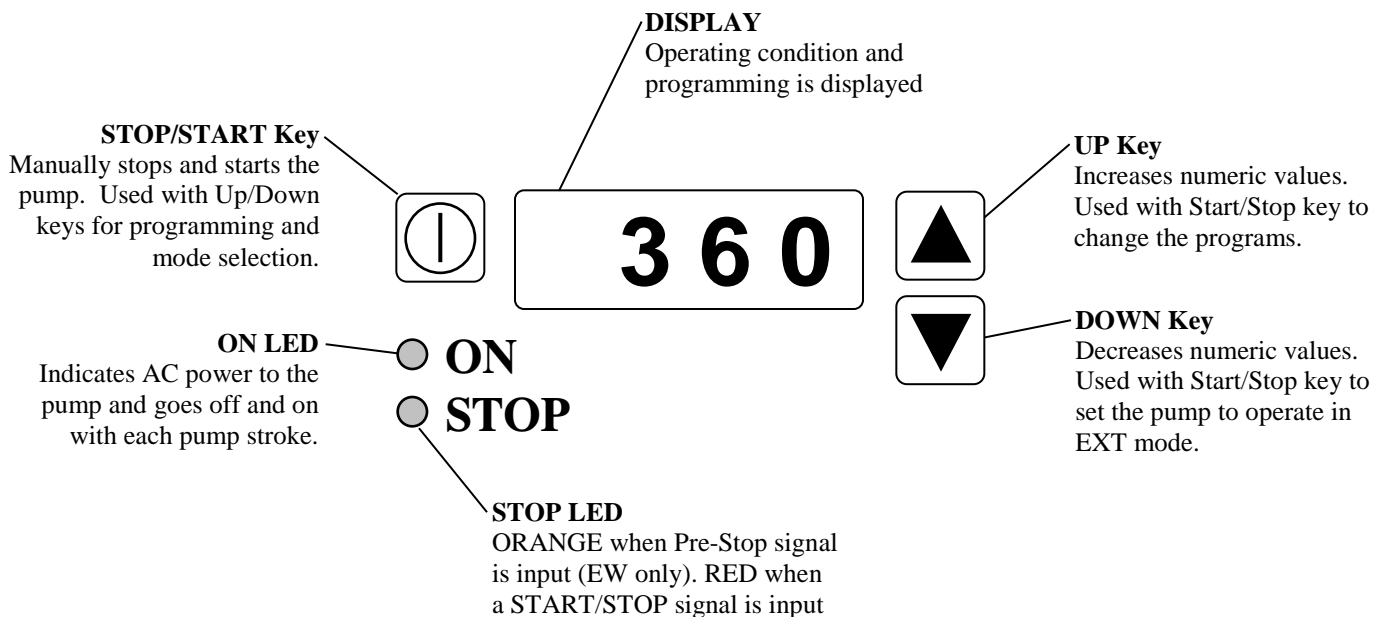

## A. Operation Overview

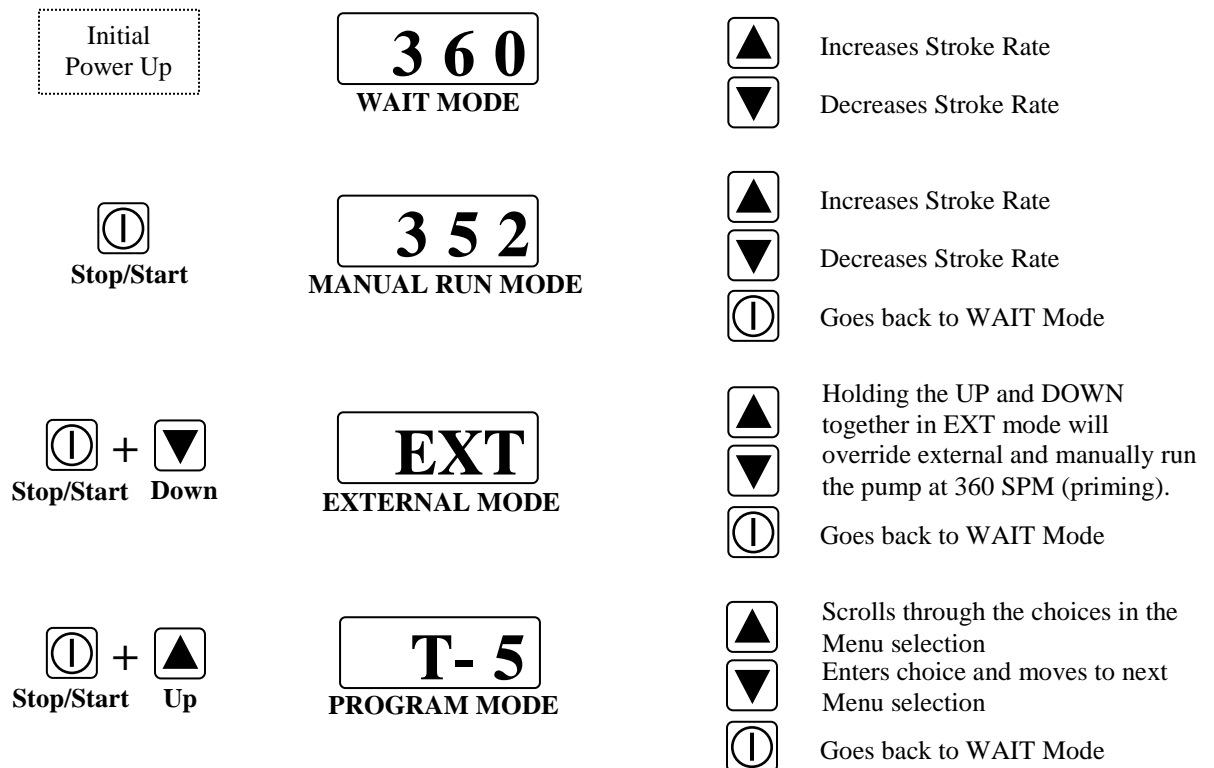
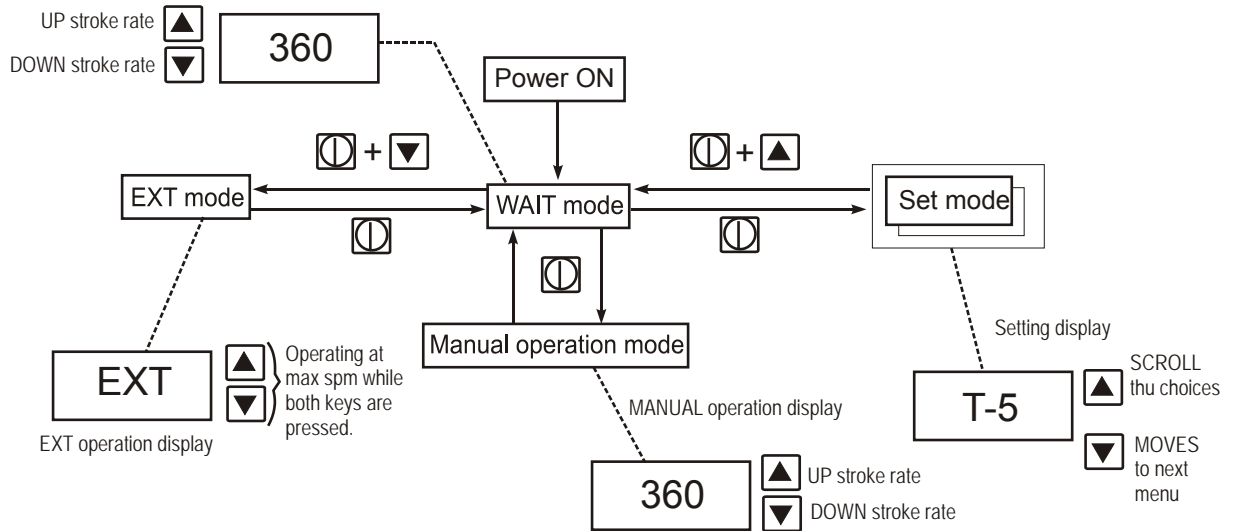

## **B. Programming**

Pressing the stop/start and up keys simultaneously will enter the program mode. The up and down keys scroll through the menus and choices and the stop/start key will exit back to the wait mode.

### **On-Time Menu**

The first item displayed will be the factory set choice of the External Input On-Time menu (T-5). There are three choices in this menu: T-5, T-20, and T-50 that can be scrolled through by repeatedly pressing the up key. These settings are time in milliseconds and correlate to the required minimum closure time of the external input signal for the pump to recognize it as a true signal. Selecting the smaller T-5 (5 msec) will allow shorter duration pulses to be recognized (typical for Hall Effect input), while the T-50 (50 msec) setting will help to reduce erroneous pulses from noise (as from a reed switch).

### **Stop Input NO/NC Selection**

Pressing the down key will move from the External Input On-Time menu to the Stop menu and the initial factory setting is M-OFF (input is normally open and contact closure will stop the pump). Pressing the up key will toggle between M-OFF and M-ON. Setting the pump to M-ON means that the pump will be stopped continuously and a contact closure into the stop/start input will now start the pump and the pump will run as long as the contact is made.

Pressing the down key will again move back to the On-Time menu and pressing the stop/start key will go back to the wait mode.

## **C. Pump Operation**

### ***Manual and On/Off Control***

The pumps can be operated manually by pressing the stop/start key from the wait mode. Once pressed, the pump will begin to operate at the stroke rate shown on the display. From here, the up and down keys can be used to change the stroke rate, and the stroke length knob can be adjusted down to further reduce the pump output.

Once adjusted/calibrated to the desired flow rate, the pump can be left in manual mode for on/off control via power (connecting/disconnecting AC power from an external source) or for on/off control via the stop/start input. Pressing the stop/start key will go back to the wait mode.

### ***External Control***

Pressing the stop/start key and the down key simultaneously from the wait mode will set the pump to operate in external mode. In this mode, the pump will operate at a speed correlating to the frequency of digital inputs that it receives (see section 3.2 for wiring inputs). If used, the stop/start input will override the digital input signals.

If at any time in external mode the up and down keys are held down simultaneously, the pump will manually run at 360 SPM as long as the two keys are held down. This feature is useful for priming or the elimination of air trapped in the pump or tubing.

Pressing the stop/start key will disable external control and go back to the wait mode.



### 3.2 External Inputs & Outputs

The EW and EK pumps are capable of being controlled by an external pulse proportional input as well as being controlled by an external stop/start signal. Additionally, the EW pumps have two contact closure relay outputs – one output is synchronous with the pump frequency and the other is tied to the external stop/start signal.

#### A. EW Pumps and the ‘F’ control module

Two circular mini-DIN female connectors are used to make these connections. Figure 9 shows the mating connections on the back of the pump. Connector 1 is a 5-PIN standard-key connector (P/N E90495) and Connector 2 is a 4-PIN reverse-key connector (P/N E90494).

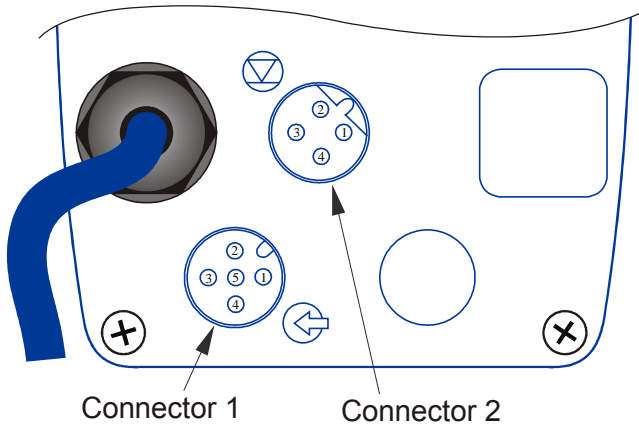

Figure 9

#### CONNECTOR 1:

PIN	FUNCTION
1	Voltage In (24VDC max)
2	External Digital Input
3	Out 2 (Synchronous with stroke)
4	Out 1 (Stop output)
5*	Common

#### CONNECTOR 2:

PIN	FUNCTION
1	Stop/Start Input
2	Pre-Stop Input
3	Not Used
4	Common

\*Note: The center pin is marked as ‘5’ for easy identification purposes throughout the manual. Actual marking on the part may be any capital letter (mold cavity ID) or the number ‘5’.

#### External Control

The external pulse input should not exceed 360 pulses per minute (6Hz) and the pump will output one stroke for every input pulse. The control signal can be a contact closure type switch (reed) with a max load of 1mA or a solid state device. If a solid state device is used, the external circuit should be capable of switching 5VDC at 1.2mA with an active duty cycle pulse width of 5ms to 100ms (actual closure time).

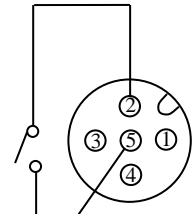

To connect the pulse input from an external device, wire PINs 2 and 5 from the contact closure. If using a solid state switching device, wire the connector ensuring that PIN 2 is positive (+) and PIN 5 is Common (-).

#### Stop/Start and Pre-Stop Control

The EW pumps have two stop inputs. The Pre-Stop is an external input that changes the green STOP LED to orange to signal a “LOW” condition. This input does not control the pump. An external Stop/Start signal, however, not only turns the STOP LED to red, but also controls the pump. In this mode, AC power is applied continuously, but the pump operation is stopped (or started – see section on programming) by completing the circuit between PIN 1 and PIN 4 in Connector 2. Both the Pre-Stop and Stop/Start signals can be a contact closure type switch (reed) with a max load of 1mA or a solid state device. If a solid state device is used, the external circuit should be capable of switching 5VDC at 1.2mA with an active duty cycle pulse width of 5ms to 100ms (actual closure time).

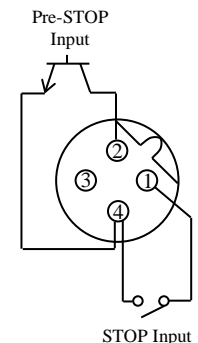

To connect the Pre-Stop input from an external device, wire PINs 2 and 4 from the contact closure. If using a solid state switching device, wire the connector ensuring that PIN 2 is positive (+) and PIN 4 is Common (-).

To connect the Stop/Start input from an external device, wire PINs 1 and 4 from the contact closure. If using a solid state switching device, wire the connector ensuring that PIN 1 is positive (+) and PIN 4 is Common (-).

**Output Relays**

The EW pumps have two output relays (non-isolated PNP transistors with a 330Ω resistance) in Connector 1. Output 1 is tied to the Stop/Start input and will activate when a Stop/Start input connection is made. Output 2 activates synchronously with the pump stroke rate.

**Contact Closure Type Outputs**

The EW circuit can make either the Stop/Start (Out 1) or the synchronous pulse (Out 2) function as contact closures, but ONLY ONE output can be used at a time. To use the synchronous pulse out, connect the positive side to PIN 1 and the negative side to PINS 3&5 (jumped together). To use the start/stop output, connect the positive side to PIN 1 and the negative side to PINS 4&5 (jumped together).

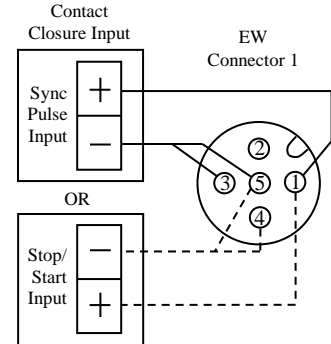

**Voltage Input Type Outputs (Non-Contact Closure)**

PIN 1 will take a voltage in from an external source (max 24VDC). When this external voltage is present, then both relays will independently switch the input voltage. Both outputs can be used simultaneously. The figure to the left shows a schematic with the output relays configured to switch the powered input. This setup can only be used with voltage input type circuits (not contact closure types) such as those commonly found in a PLC.

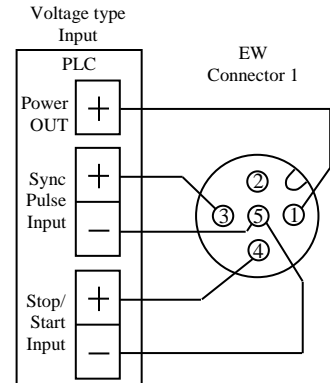

## B. EK Pumps and the 'R' control module

One custom watertight connector is used for the digital input and stop/start connections on the EK pumps. There are no outputs on the EK pumps. The Connector Holder is keyed to fit into the pump only one direction. There is a set of painted alignment marks on the connector and connector holder that identify the correct orientation of the connector. Be sure to double check that the connector is installed properly into the connector assembly before installation onto the pump.

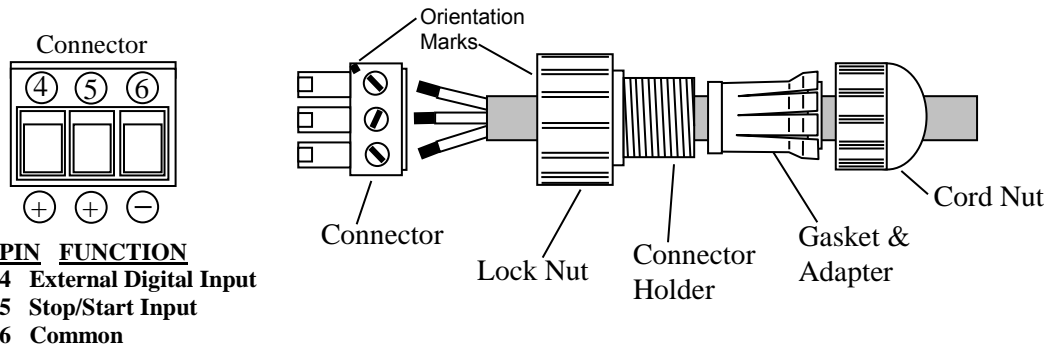

### *Digital Control*

The external pulse input should not exceed 360 pulses per minute (6Hz) and the pump will output one stroke for every input pulse. The control signal can be a contact closure type switch (reed) with a max load of 1mA or a solid state device. If a solid state device is used, the external circuit should be capable of switching 5VDC at 1.2mA with an active duty cycle pulse width of 5ms to 100ms (actual closure time).

To connect the pulse input from an external device, wire Terminal 4 and Terminal 6 from the contact closure. If using a solid state switching device, wire the connector ensuring that Terminal 4 is positive (+) and Terminal 6 is Common (-).

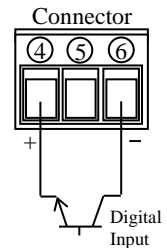

### ***Stop/Start Control***

An external Stop/Start signal will turn the STOP LED to red and also control the pump. In this mode, AC power is applied continuously, but the pump operation is stopped (or started – see section on programming) by completing the circuit between Terminal 5 and Terminal 6. The Stop/Start signal can be a contact closure type switch (reed) with a max load of 1mA or a solid state device. If a solid state device is used, the external circuit should be capable of switching 5VDC at 1.2mA with an active duty cycle pulse width of 5ms to 100ms (actual closure time).

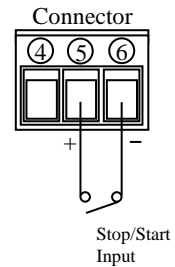

To connect the Stop/Start input from an external device, wire Terminals 5 and 6 from the contact closure. If using a solid state switching device, wire the connections ensuring that Terminal 5 is positive (+) and Terminal 6 is Common (-).

## **3.3 Adjustment**

### **A. EW Pumps using the ‘F’ Control Module**

The pump will operate best keeping the stroke length at 100%. If less than full output is required, set the frequency to the approximate percentage of maximum desired.

Example: Model EWB21F1-VC has maximum output of 1.8 GPH.

Desired output is 1.2 GPH.  $1.2 \div 1.8 = 0.667$  or 67%

Using the UP and DOWN arrows, set the frequency of the pump to  $0.67 \times 360 = 241$  SPM.

For outputs less than 2% of maximum it will be necessary to also reduce the stroke length. (Minimum recommended stroke length is 20%.) It is good practice to change the frequency first, however, if low flows are required, a balanced turndown of speed and stroke length will yield the best results.

### **B. EK Pumps using the ‘R’ Control Module**

The pump will operate best keeping the stroke length at 100%. If less than full output is required, set the frequency to the approximate percentage of maximum desired.

Example: Model EKC21R1-VC has maximum output of 4.3 GPH.

Desired output is 3.0 GPH.  $3.0 \div 4.3 = 0.7$  or 70%

Using the UP and DOWN arrows, set the frequency of the pump to  $0.7 \times 360 = 252$  SPM.

For outputs less than 2% of maximum it will be necessary to also reduce the stroke length. (Minimum recommended stroke length is 20%.) It is good practice to change the frequency first, however, if low flows are required, a balanced turndown of speed and stroke length will yield the best results.

### 3.4 MultiFunction Valve Operation

The MultiFunction Valve is optional on select E-Class pumps and replaces the standard Manual Air Vent Valve when ordered. It integrates the air venting/bleeding functions with a back pressure and anti-siphon valve.

#### Air Vent / Bleed Function

1. Open the air vent by turning the air vent adjustment knob counter-clockwise one to one and a half turns.
2. Operate the pump until all of the air is purged and only liquid is discharged from the air vent drain.
3. Turn the air vent adjustment knob clockwise until it bottoms out and will not turn further.

#### Back Pressure / Anti-Siphon Valve

1. A spring-loaded diaphragm automatically adds 30PSI of back pressure to the discharge side of the pump when the air vent adjustment knob is closed.
2. If back pressure is not observed, the pressure release knob may be in the release position (the knob is resting in its 'up' location). If this is the case, turn the knob clockwise until it 'clicks' down (approximately ¼ turn).
3. The diaphragm prevents siphoning of chemical through the pump.

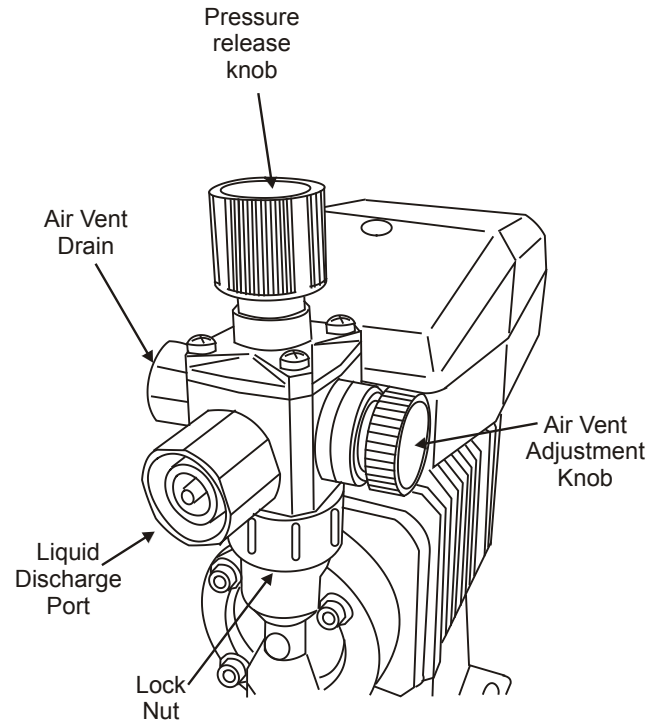

#### Pressure Release

1. Stop the pump operation.
2. Turn the pressure release knob clockwise until it 'clicks' into the release or 'up' location (approximately ¼ turn). If the knob is turned too far, it will 'click' again return to the back pressure or 'down' position. If this happens, keep turning the knob clockwise until it 'clicks' one time in the release ('up') position. Note: To avoid damage, do not turn the knob counter-clockwise.
3. Turn the air vent adjustment knob counter-clockwise one or one and a half turns to release the pressure in the discharge tubing/piping through the air vent drain. The air vent drain should always be plumbed back to the supply tank or to safe disposal. Do not submerge the air vent drain tubing under chemical in the supply tank.



**CAUTION:** Confirm that liquid is discharged from the air vent drain. If the liquid is not discharged, the pressure may not be released. If this is the case, repeat the Pressure Release procedure.

### 3.5 Auto Air Vent Valve Operation

The Auto Air Vent Valve is an option on select EW and EK pumps and replaces the standard Manual Air Vent Valve when ordered. It is used primarily in applications where gassing is a problem and pumps can lose prime.

Unlike the Manual Air Vent Valve, the Auto Air Vent Valve constantly bleeds a controlled amount of volume out of the “Air” vent. Therefore, the “Air” vent should *always* be plumbed back to the source tank. During priming, the access knob does not have to be loosened as with a manual air vent valve as pressure is relieved through the vent. The Top Valve Guide assembly uses a bottom seat to ensure that air is not introduced into the discharge media and utilizes a precisely machined top seat that allows air to be quickly purged but limits the amount of liquid returned to the tank. A sleeve valve is used to maintain backpressure within the pump head, which helps speed the purging of air.

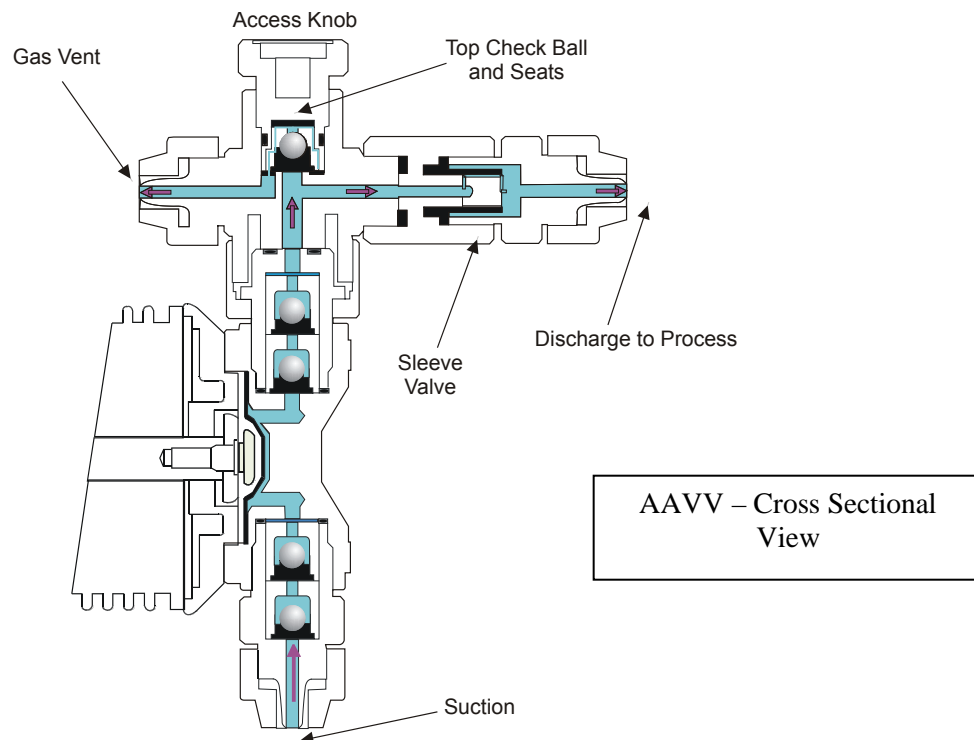

### 3.6 Priming

Install the pump as described in Section 2.0. With the pump turned on, set stroke length at 100% and frequency to 360 SPM. If the pump is equipped with an air vent valve, open the knob 1/2 turn. Liquid should move up through the suction tubing and into the pump head. When liquid starts running through the vent side tubing, close the air vent knob and continue with output adjustment described below. If the pump has no air vent valve, disconnect the discharge tubing from the injection valve. When liquid enters the discharge tubing at the pump head, stop the pump. Then reconnect the discharge tubing to the injection valve.

If the pump does not self prime, remove the check valve housing on discharge & suction sides to make sure valve cartridges and gaskets are in correct positions (see section 4.2 for correct orientation).

**Note:** Pumps with FC liquid ends may need assistance if dry priming due to the hard valve seat material.

### 3.7 Calibration

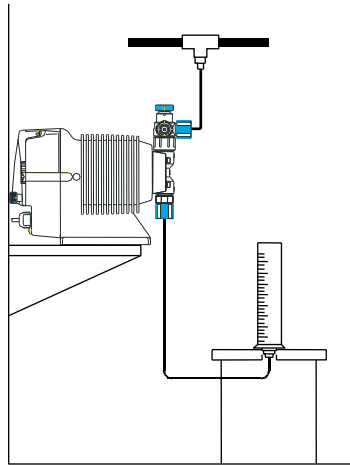

Figure 8 Calibration

If exact output calibration is required, first prime and adjust the pump as above. Then connect a calibration column to the suction side of the pump. Turn the pump on for one minute and read the amount of liquid pumped from the column. Adjust the frequency up or down as necessary and check the output again. When the desired output is reached, disconnect the calibration column and reconnect the suction tubing. (See Figure 8.) Calibration must be performed with actual application equivalent back pressure for accurate results. Published flow rates are based on maximum pressures. Lower pressures may result in slightly higher flow rates.

### 3.8 AC Power Interruption

If AC power is interrupted, the pump will power up as shown below:

State preceding power OFF	State following power ON
WAIT	WAIT
Run Manual	Run Manual
Run external	Run external

## 4.0 MAINTENANCE



**CAUTION:** Before working on the pump, disconnect the power cord, depressurize the discharge tubing and drain or flush any residual liquid from the pump head and valves. Always wear protective gear when working around chemicals.

### 4.1 Diaphragm Replacement

Disconnect AC power to the pump and disconnect the suction tubing, discharge tubing, and air vent tubing. Remove the four head bolts with a 4mm or 5mm hex wrench. Turn the stroke length knob fully counter-clockwise. Unscrew the diaphragm and remove its retainer (small disk behind the diaphragm).



**CAUTION:** *There may be small brass spacers between the retainer and the armature shaft. These spacers need to be reused when replacing the diaphragm.*

Install the new retainer and diaphragm on the shaft. Turn the diaphragm clockwise until it bottoms on the shaft. Use caution when handling the diaphragm – the PTFE surface can be damaged by tools, nails, or any sharp objects. Replace the pump head and tighten the head bolts to a torque of 19 lb-in (2.16 N-m).

### 4.2 Valve Replacement

Remove the suction and discharge tubing making sure discharge side has been depressurized. Remove the suction fitting, two valve cartridges, o-ring and gasket(s). Install the new o-ring, gasket(s) and valve cartridges. Be sure both valve seats are in the same orientation. Refer to Figure below. Tighten the suction fitting. Similarly remove and replace the discharge valve cartridges, o-ring and gasket(s). For a more detailed drawing, refer to the Section 6.0.

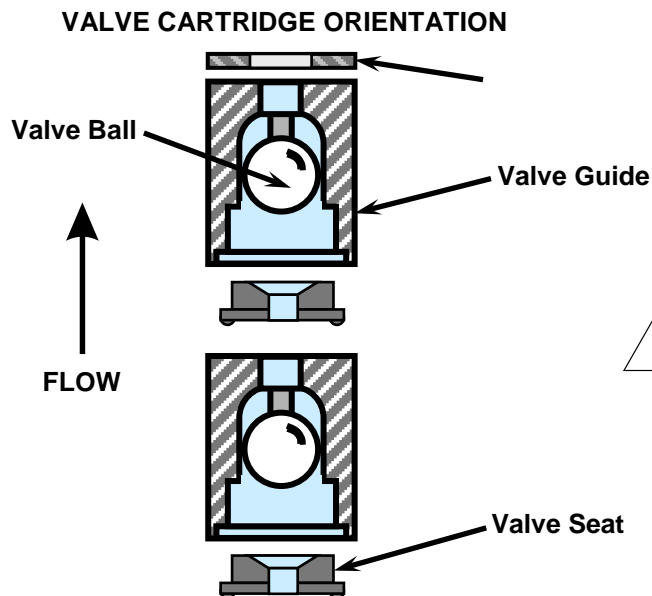

**CAUTION:** There are many small parts in the liquid end. These parts must be installed correctly for proper operation of the pump.

### 4.3 Tubing

Check ends of tubing for splits, cracks, or thin spots. Examine the full length of tubing for damage due to chafing, abrasion, stress cracks, excessive temperature or exposure to ultraviolet light (direct sunlight or mercury vapor lamps). If any signs of deterioration exist, replace the entire length of tubing. It is a good idea to replace discharge tubing on a regular preventive maintenance schedule every 12 months.



# 5.0 EXPLODED VIEW & PARTS GUIDE

## PVC/GFRPP Liquid End Exploded View #1 For EW and EK pump model sizes 11, 16, and 21

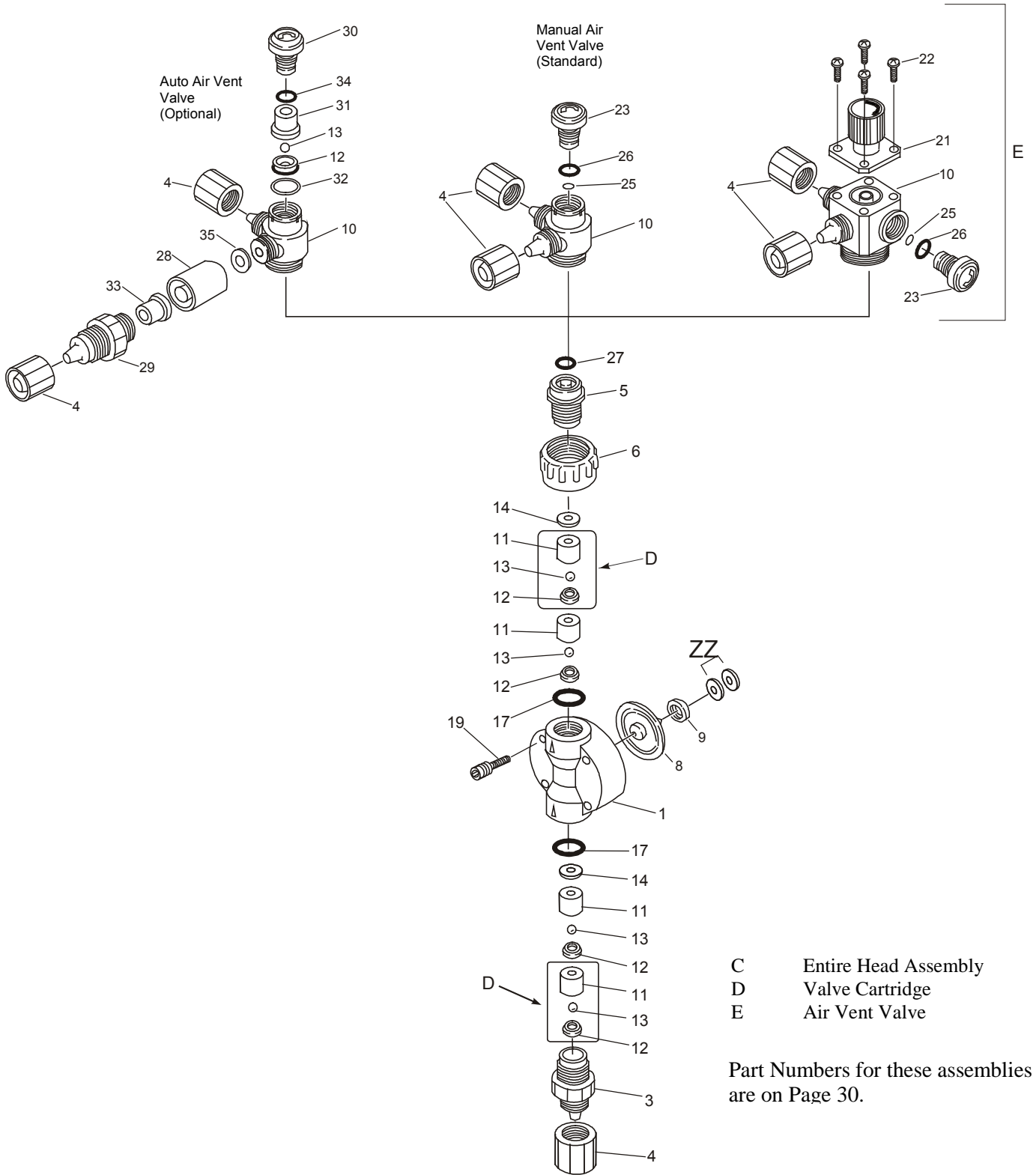

## PVC/GFRPP Liquid End Exploded View #1

### Components

Item	Part No	Description	Qty	Size	Liquid End Material	
1	EH2015	Head, Pump, EW/EKB11, PVC	1	11	VC, VE, VF, VCA	
	EH2017	Head, Pump, EW/EKB11, GFRPP	1	11	PC, PE	
	EH1950	Head, Pump, EW/EK/EZ16, PVC	1	16	VC, VE, VF, VCA	
	EH1957	Head, Pump, EW/EK/EZ16, GFRPP	1	16	PC, PE	
	EH1951	Head, Pump, EW/EK/EZ21, PVC	1	21	VC, VE, VF, VCA	
	EH1958	Head, Pump, EW/EK/EZ21, GFRPP	1	21	PC, PE	
3	EH0400	Housing, Valve, 3/8 PVC	1	11, 16, 21	VC, VE, VF, VCA	
	EH0418	Housing, Valve, 3/8 GFRPP	1	11, 16, 21	PC, PE	
4	EH0401	Nut, Coupling, 3/8 PVC	3	11, 16, 21	VC, VE, VF, VCA	
	EH0419	Nut, Coupling, 3/8 GFRPP	3	11, 16, 21	PC, PE	
5	EH0294	Fitting, Air Vent, PVC	1	11, 16, 21	VC, VE, VF, VCA	
	EH0315	Fitting, Air Vent, GFRPP	1	11, 16, 21	PC, PE	
6	EH0295	Nut, Lock, Air Vent, PVC	1	11, 16, 21	VC, VE, VF, VCA	
	EH0316	Nut, Lock, Air Vent, GFRPP	1	11, 16, 21	PC, PE	
*	8	EH1971	Diaphragm, EW/EK/EZ11	1	11	all
	EH1972	Diaphragm, EW/EK/EZ16	1	16	all	
	EH1973	Diaphragm, EW/EK/EZ21	1	21	all	
*	9	EH0059	Retainer, EW/EK/EZ11	1	11	all
	EH0083	Retainer, EW/EK/EZ16	1	16	all	
	EH0067	Retainer, EW/EK/EZ21	1	21	all	
10	EH0402	Body, Manual Air Vent, PVC	1	11, 16, 21	VC, VE, VF	
	EH0420	Body, Manual Air Vent, GFRPP	1	11, 16, 21	PC, PE	
	EH0861	Body, Auto Air Vent, PVC	1	11, 16, 21	VCA	
	EH1406	Body, Multifunction Valve, PVC	1	11, 16, 21	VCM, VEM, VFM	
	EH1407	Body, Multifunction Valve, GFRPP	1	11, 16, 21	PCM, PEM	
*	11	EH0060	Guide, Valve, 0.188 PVC	4	11	VC, VE, VF, VCA
	EH0318	Guide, Valve, 0.188 GFRPP	4	11	PC, PE	
	EH0068	Guide, Valve, 0.250 PVC	4	16, 21	VC, VE, VF, VCA	
	EH1534	Guide, Valve, 0.250 GFRPP	4	16, 21	PC, PE	
*	12	EH0061	Seat, Valve, 0.188 FKM	4 (5)	11	VC, PC (VCA)
	EH0048	Seat, Valve, 0.188 EPDM	4	11	VE, PE, VF	
	EH0069	Seat, Valve, 0.250 FKM	4	16, 21	VC, PC	
	EH0071	Seat, Valve, 0.250 EPDM	4	16, 21	VE, PE, VF	
*	13	EH0025	Ball, Valve, 0.188 CE	4 (5)	11	VC, VE, PC, PE, (VCA)
	EH0084	Ball, Valve, 0.250 CE	4	16, 21	VC, VE, PC, PE	
	E00063	Ball, Valve 0.188 PTFE	4	11	VF	
	E00064	Ball, Valve 0.250 PTFE	4	16, 21	VF	
*	14	EH0026	Gasket, Valve, 0.188 & 0.250 PTFE	2	11, 16, 21	VC, VE, VF, VCA
	EH0580	Gasket, Valve, 0.188 & 0.250 PTFE	2	11, 16, 21	PC, PE	
*	17	EH0027	O-Ring, S14 FKM	2	11, 16, 21	VC, PC, VCA
	EH0050	O-Ring, S14 EPDM	2	11, 16, 21	VE, PE, VF	
19	EH1986	Bolt, M4 x 35 w/PW & SW, 316SS	4	11, 16, 21	all	
21	E90374	Multifunction Valve Top Asm	1	11, 16, 21	all xxM ends	
22	EH1410	Screw, M4 x 35 w/PW & SW, 316SS	4	11, 16, 21	all xxM ends	
23	EH0299	Knob, Manual Air Vent Valve, PVC	1	11, 16, 21	VC, VE, VF	
	EH0321	Knob, Manual Air Vent Valve, GFRPP	1	11, 16, 21	PC, PE	
*	25	EH0300	O-Ring, P4 FKM	1	11, 16, 21	VC, PC, VCA
	EH0301	O-Ring, P4 EPDM	1	11, 16, 21	VE, PE, VF	
*	26	EH0302	O-Ring, P10A FKM	1	11, 16, 21	VC, PC, VCA
	EH0303	O-Ring, P10A EPDM	1	11, 16, 21	VE, PE, VF	
*	27	EH0304	O-Ring, P7 FKM	1	11, 16, 21	VC, PC, VCA
	EH0305	O-Ring, P7 EPDM	1	11, 16, 21	VE, PE, VF	
28	EH0864	Fitting, Adapter, AAVV, PVC	1	11, 16, 21	VCA	
29	EH0867	Fitting, AAVV, PVC	1	11, 16, 21	VCA	
30	EH0774	Knob, AAVV, PVC	1	11, 16, 21	VCA	
31	EH0862	Guide, Valve, AAVV, Titanium	1	11, 16, 21	VCA	
	E00080	Guide, Valve, AAVV, HC276	1	11, 16, 21	VCA-H	
32	EH0775	Spacer, AAVV, PVC	1	11, 16, 21	VCA	
*	33	EH0865	Tube, Valve, AAVV, FKM	1	11, 16, 21	VCA
*	34	EH0776	O-Ring, S12, FKM	1	11, 16, 21	VCA
35	EH0866	Gasket, AAVV, FKM	1	11, 16, 21	VCA	
ZZ	-----	Brass Spacers			Drive specific/Reuse when replacing diaphragm	

\* Included in spare parts kit

**PVC/GFRPP Liquid End Exploded View #2**  
 For EW and EK pump model sizes 31 and 36

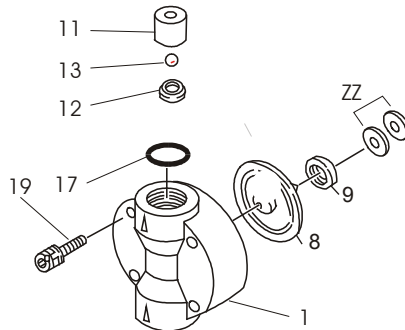
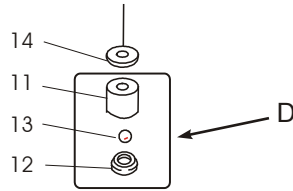
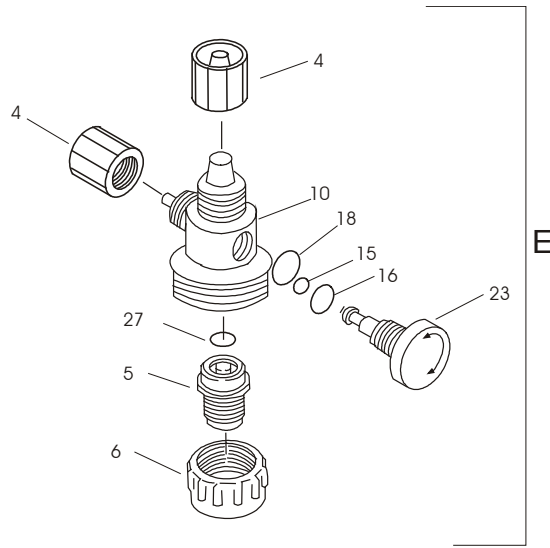

- C Entire Head Assembly
- D Valve Cartridge
- E Air Vent Valve

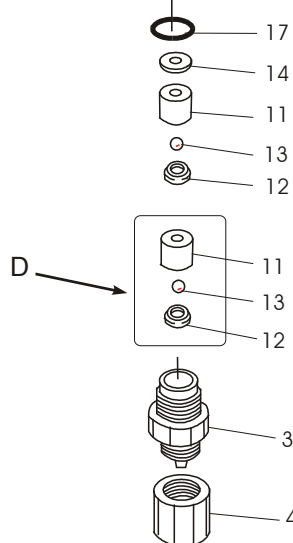

Part Numbers for these assemblies  
 are on Page 30.

## PVC/GFRPP Liquid End Exploded View #2

### Components

Item	Part No	Description	Qty	Size	Liquid End Material	
1	EH1961	Head, Pump, EW/EK31, GFRPP	1	31	PC, PE	
	EH1960	Head, Pump, EW/EK31, PVC	1	31	VC, VE, VF	
	EH1962	Head, Pump, EW/EK36, GFRPP	1	36	PC, PE	
	EH1953	Head, Pump, EW/EK36, PVC	1	36	VC, VE, VF	
3	EH0405	Housing, Valve, 1/2 PVC	1	31, 36	VC, VE, VF	
	EH0421	Housing, Valve, 1/2 GFRPP	1	31, 36	PC, PE	
4	EH0406	Nut Coupling, 1/2 PVC	3	31, 36	VC, VE, VF	
	EH0422	Nut, Coupling, 1/2 GFRPP	3	31, 36	PC, PE	
5	EH1078	Fitting, Air Vent, PVC	1	31, 36	VC, VE, VF	
	EH1088	Fitting, Air Vent, GFRPP	1	31, 36	PC, PE	
6	EH1077	Nut, Lock, Air Vent, PVC	1	31, 36	VC, VE, VF	
	EH1087	Nut, Lock, Air Vent, GFRPP	1	31, 36	PC, PE	
*	8	EH1974	Diaphragm, EW/EK/EZ31	1	31	all
	EH1975	Diaphragm, EW/EK/EZ36	1	36	all	
*	9	EH0087	Retainer, EW/EK/EZ31	1	31	all
	EH0158	Retainer, EW/EK/EZ36	1	36	all	
10	EH1101	Body, Manual Air Vent, PVC	1	31, 36	VC, VE, VF	
	EH1099	Body, Manual Air Vent, GFRPP	1	31, 36	PC, PE	
*	11	EH0118	Guide, Valve, 0.375 PVC	4	31, 36	VC, VE, VF
	EH0332	Guide, Valve, 0.375 GFRPP	4	31, 36	PC, PE	
*	12	EH0119	Seat, Valve, 0.375 FKM	4	30.35	VC, PC
	EH0125	Seat, Valve, 0.375 EPDM	4	31, 36	VE, PE, VF	
*	13	EH0120	Ball, Valve, 0.375 CE	4	31, 36	VC, VE, PC, PE
	E00062	Ball, Valve, 0.375 PTFE	4	31, 36	VF	
*	14	EH0121	Gasket, Valve, 0.375 PTFE	2	31, 36	VC, VE, PC, PE, VF
*	15	EH1080	O-Ring, P-3, FKM	1	31, 36	VC, PC
	EH1083	O-Ring, P-3, EPDM	1	31, 36	VE, PE, VF	
*	16	EH0029	O-Ring, P-6, FKM	1	31, 36	VC, PC
	EH0052	O-Ring, P-6, EPDM	1	31, 36	VE, PE, VF	
*	17	EH0122	O-Ring, P16 FKM	2	31, 36	VC, PC
	EH0127	O-Ring, P16 EPDM	2	31, 36	VE, PE, VF	
*	18	EH0027	O-Ring, S-14 FKM	1	31, 36	VC, PC
	EH0050	O-Ring, S-14 EPDM	1	31, 36	VE, PE, VF	
19	EH1986	Bolt, M4 x 35 w/PW & SW, 316SS	4	31	all	
	EH1988	Bolt, M5 x 35 w/PW & SW, 316SS	4	36	all	
23	EH1079	Knob, Manual Air Vent, PVC	1	31, 36	VC, VE, VF	
	EH1089	Knob, Manual Air Vent, GFRPP	1	31, 36	PC, PE	
*	27	EH1082	O-Ring, P-11 FKM	1	31, 36	VC, PC
	EH1084	O-Ring, P-11, EPDM	1	31, 36	VE, PE, VF	
ZZ	-----	Brass Spacers			Drive specific/Reuse when replacing diaphragm	

\* Included in spare parts kit

### PVDF Liquid End Exploded View #3 For all PVDF EW and EK Pump Models

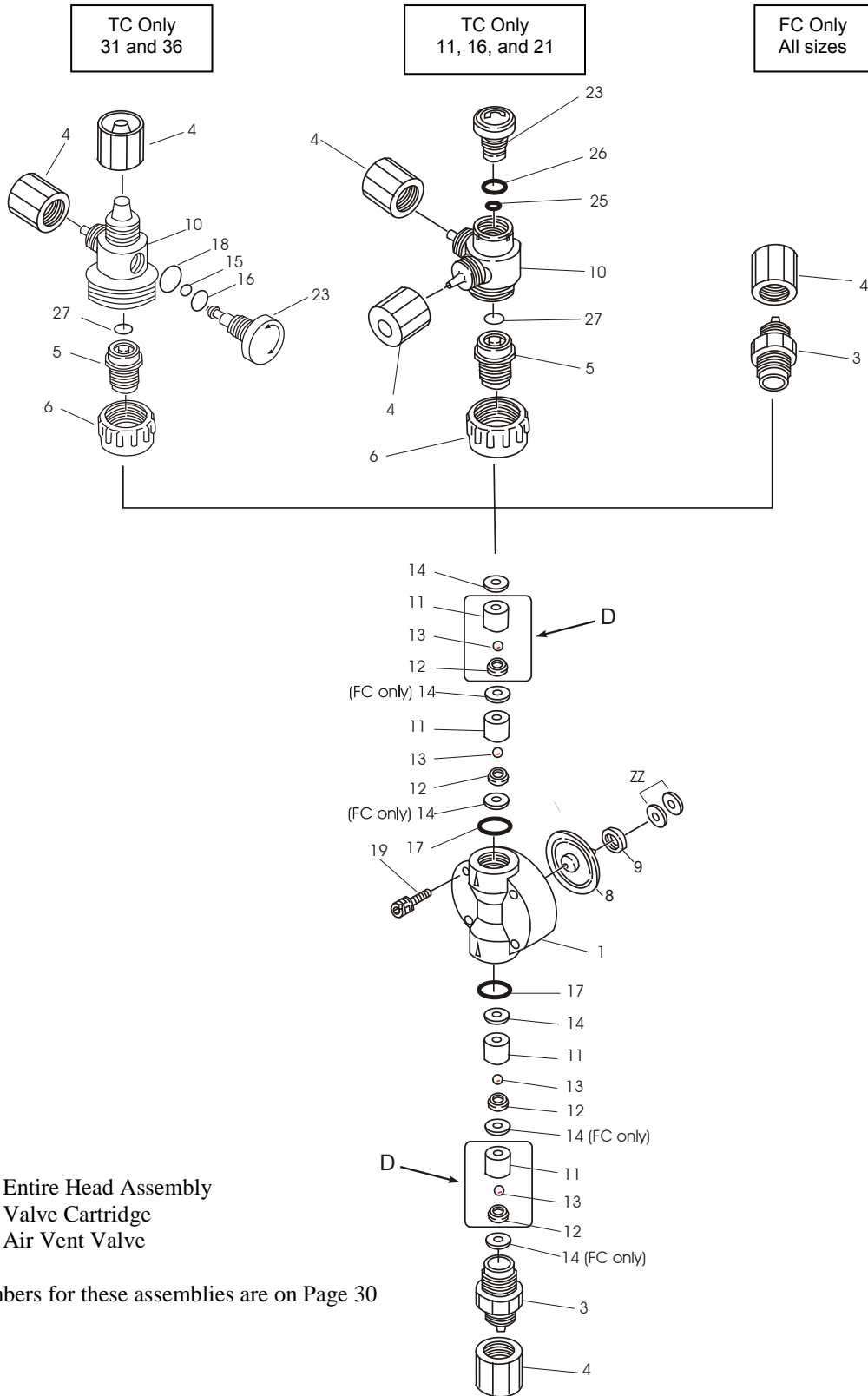

### PVDF Liquid End Exploded View #3

#### Components

Item	Part No	Description	Qty	Size	Liquid End Material	
1	EH2019	Head, Pump, EW/EKB11, PVDF	1	11	FC, TC	
	EH1970	Head, Pump, EW/EK16, PVDF	1	16	FC, TC	
	EH1965	Head, Pump, EW/EK21, PVDF	1	21	FC, TC	
	EH1966	Head, Pump, EW/EK31, PVDF	1	31	FC, TC	
	EH1967	Head, Pump, EW/EK36, PVDF	1	36	FC, TC	
3	EH0425	Housing, Valve, 3/8 PVDF	2 / 1	11, 16, 21	FC, TC	
	EH0427	Housing, Valve, 1/2 PVDF	2 / 1	31, 36	FC, TC	
4	EH0836	Nut, Coupling, 3/8 PVDF	2 / 3	11, 16, 21	FC, TC	
	EH0837	Nut, Coupling, 1/2 PVDF	2 / 3	31, 36	FC, TC	
5	EH1051	Fitting, Air Vent, PVDF	1	11, 16, 21	TC	
	EH1093	Fitting, Air Vent, PVDF	1	31, 36	TC	
6	EH1047	Nut, Lock, Air Vent, PVDF	1	11, 16, 21	TC	
	EH1092	Nut, Lock, Air Vent, PVDF	1	31, 36	TC	
*	8	EH1971	Diaphragm, EW/EK/EZ11	1	11	all
	EH1972	Diaphragm, EW/EK/EZ16	1	16	all	
	EH1973	Diaphragm, EW/EK/EZ21	1	21	all	
	EH1974	Diaphragm, EW/EK/EZ31	1	31	all	
	EH1975	Diaphragm, EW/EK/EZ36	1	36	all	
*	9	EH0059	Retainer, EW/EK/EZ11	1	11	all
	EH0083	Retainer, EW/EK/EZ16	1	16	all	
	EH0067	Retainer, EW/EK/EZ21	1	21	all	
	EH0087	Retainer, EW/EK/EZ31	1	31	all	
	EH0158	Retainer, EW/EK/EZ36	1	36	all	
10	EH1052	Body, Manual Air Vent, PVDF	1	11, 16, 21	TC	
	EH1100	Body, Manual Air Vent, PVDF	1	31, 36	TC	
*	11	EH0340	Guide, Valve, 0.188 PVDF	4	11	FC
	EH1046	Guide, Valve, 0.188 PVDF	4	11	TC	
	EH1549	Guide, Valve, 0.250 PVDF	4	16, 21	FC, TC	
	EH0352	Guide, Valve, 0.375 PVDF	4	31, 36	FC	
	EH2368	Guide, Valve, 0.375 PVDF (EW/EWN)	4	31, 36	TC	
*	12	EH1627	Seat, Valve, 0.188 PCTFE	4	11	TC
	EH0592	Seat, Valve, 0.250 PCTFE	4	16, 21	FC	
	EH0593	Seat, Valve, 0.375 PCTFE	4	31, 36	FC	
	EH0061	Seat, Valve, 0.188 FKM	4	11	TC	
	EH0069	Seat, Valve, 0.250 FKM	4	16, 21	TC	
	EH0119	Seat, Valve, 0.375 FKM	4	31, 36	TC	
*	13	EH0025	Ball, Valve, 0.188 CE	4	11	FC, TC
	EH0084	Ball, Valve, 0.250 CE	4	16, 21	FC, TC	
	EH0120	Ball, Valve, 0.375 CE	4	31, 36	FC, TC	
*	14	EH0342	Gasket, Valve, 0.188 & 0.250 PTFE	6	11, 16, 21	FC
	EH1553	Gasket, Valve, 0.188 & 0.250 PTFE	2	11, 16, 21	TC	
	EH0354	Gasket, Valve, 0.375, PTFE	6	31, 36	FC	
	EH0121	Gasket, Valve, 0.375, PTFE	2	31, 36	TC	
*	15	EH1080	O-Ring, P-3, FKM	1	31, 36	TC
*	16	EH0029	O-Ring, P-6, FKM	1	31, 36	TC
*	17	EH0027	O-Ring, S-14, FKM	2	11, 16, 21	TC
	EH0122	O-Ring, P-16, FKM	2	31, 36	TC	
	EH0591	Gasket, V-Housing, 0.188/0.250 PTFE	2	11, 16, 21	FC	
	EH0355	Gasket, V-Housing, 0.375 PTFE	2	31, 36	FC	
*	18	EH0027	O-Ring, S-14, FKM	1	31, 36	TC
19	EH1986	Bolt, M4 x 35 w/PW & SW, 316SS	4	11, 16, 21, 31	FC, TC	
	EH1988	Bolt, M5 x 35 w/PW & SW, 316SS	4	36	FC, TC	
23	EH1049	Knob, Air Vent Valve	1	11, 16, 21	FC, TC	
	EH1094	Knob, Air Vent, 1/2, PVDF	1	31, 36	FC, TC	
*	25	EH0300	O-Ring, P-4, FKM	1	11, 16, 21	TC
*	26	EH0302	O-Ring, P-10A, FKM	1	11, 16, 21	TC
*	27	EH0304	O-Ring, P-7, FKM	1	11, 16, 21	TC
	EH1082	O-Ring, P-11, FKM	1	31, 36	TC	
ZZ	-----	Brass spacers			Drive specific/Re-use when replacing diaphragm	
*		Included in spare parts kit				

## Stainless Steel Liquid End Exploded View #4

For all EW and EK Pump Models

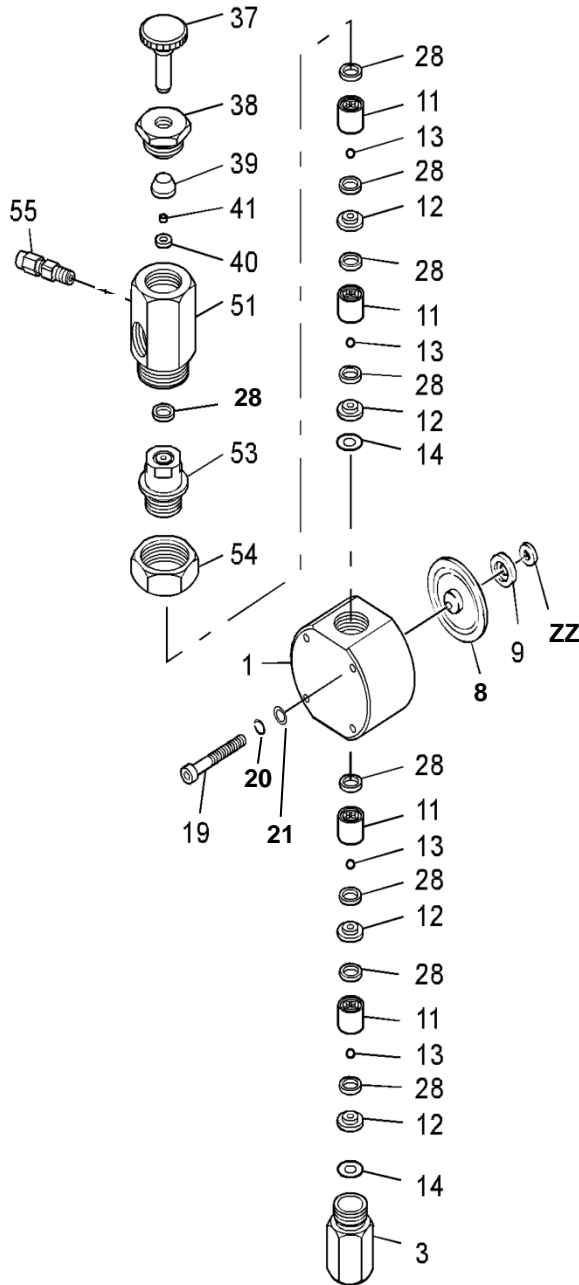

### Components

Item	Part No	Description	Qty	
1	EH2021	Head, Pump, EW/EKB11, 316 SS	1	
	EH2022	Head, Pump, EW/EK21, 316 SS	1	
	EH2023	Head, Pump, EW/EK31, 316 SS	1	
	EH2024	Head, Pump, EW/EKC36, 316 SS	1	
3	EH0429	Housing, Valve, 0.188 & 0.250, 316 SS	1	
	EH0433	Housing, Valve, 0.375, 316 SS	1	
*	8	EH1971	Diaphragm, EW/EK11, PTFE/EPDM	1
	EH1973	Diaphragm, EW/EK21, PTFE/EPDM	1	
	EH1974	Diaphragm, EW/EK31, PTFE/EPDM	1	
	EH1975	Diaphragm, EW/EK36, PTFE/EPDM	1	
*	9	EH0059	Retainer, Diaphragm, EW/EK11	1
	EH0067	Retainer, Diaphragm, EW/EK21	1	
	EH0087	Retainer, Diaphragm, EW/EK31	1	
	EH0158	Retainer, Diaphragm, EW/EK36	1	
11	EH0360	Guide, Valve, EW/EKB11, 316 SS	4	
	EH1551	Guide, Valve, EW/EK211, 316 SS	4	
	EH1552	Guide, Valve, EW/EKB31/36, 316 SS	4	
12	EH1554	Seat, Valve, EW/EK11, 316 SS	4	
	EH1555	Seat, Valve, EW/EK21, 316 SS	4	
	EH1556	Seat, Valve, EW/EK31/36, 316 SS	4	
13	EH0049	Ball, Valve, 0.188, HC	4	
	EH0072	Ball, Valve, 0.250, HC	4	
	EH0126	Ball, Valve, 0.375, HC	4	
*	14	EH0362	Gasket, Valve Guide, EW/EK11/21 PTFE	2
	EH0380	Gasket, Valve Guide, EW/EK31/36, PTFE	2	
19	EH2089	Bolt, M4 x 45 316 SS, Hex Socket	4	
	EH0290	Bolt, M5 x 45 316 SS, Hex Socket	4	
20	EH2000	Washer, Split, M4, 316 SS	4	
	EH2012	Washer, Split, M5, 316 SS	4	
21	EH1999	Washer, Flat, M4, 316 SS	4	
	EH2011	Washer, Flat, M5, 316 SS	4	
*	28	EH0365	Gasket, Guide/MAVV, EW/EK11/21, PTFE	9
	EH0382	Gasket, Guide/MAVV, EW/EK31/36, PTFE	9	
37	EH1014	Knob, MAVV, EW/EK-SH, 316 SS	1	
38	EH1015	Nut, Loc, EW/EK-SH, 316 SS	1	
*	39	EH1016	Seal, Ring, EW/EK-SH, 316 SS	1
*	40	EH1017	Seat, MAVV, EW/EK-SH, 316 SS	1
*	41	EH1018	Seat Ring, MAVV, EW/EK-SH, 316 SS	1
51	EH1557	Body, MAVV, EW/EK11, 316 SS	1	
	EH1558	Body, MAVV, EW/EK31/36, 316 SS	1	
53	EH1508	Fitting, MAVV, EW/EK11, 316 SS	1	
	EH1510	Fitting, MAVV, EW/EK31/36, 316 SS	1	
54	EH1559	Nut, Lock, MAVV, EW/EW-SH, 316 SS	1	
55	EH1517	Connector, Air Vent, EW/EW-SH, ECTFE	1	
*		Included in spare parts kit		

## Accessories (Not Shown)

Part No.	Description	Size	Liquid End Material
E90494	Connector Assy, Stop Input, 4-pin-R	EW/EW-Y	all
E90495	Connector Assy, Ana/Dig Input, 5-pin	EW/EW-Y	all
E90496	Connector Assy, PosiFlow Input, 5-pin-R	EW/EW-Y	all
E90497	Connector Assy, Outputs, 4-pin-SQ	EW/EW-Y	all
E90665	Connector Assy, EK pump, Input	EK	all
E90001	Valve, Injection 3/8	11, 16, 21	VC
E90002	Valve, Injection 3/8	11, 16, 21	VE, VF
E90003	Valve, Injection, 3/8	11, 16, 21	PC
E90004	Valve, Injection, 3/8	11, 16, 21	PE
E90007	Valve, Injection, 1/2	31, 36	VC
E90008	Valve, Injection, 1/2	31, 36	VE, VF
E90011	Valve, Injection, 1/2	31, 36	PC
E90012	Valve, Injection, 1/2	31, 36	PE
E90238	Valve, Injection, 3/8	11, 16, 21	TC
E90020	Valve, Inj/Back Press, 3/8	11, 16, 21	FC
E90022	Valve, Inj/Back Press, 1/2	31, 36	TC, FC
E90013	Valve, Foot, 3/8	11, 16, 21	VC
E90015	Valve, Foot, 3/8	11, 16, 21	PC
E90016	Valve, Foot, 1/2	31, 36	VC
E90018	Valve, Foot, 1/2	31, 36	PC
E90034	Valve, Foot, 3/8	11, 16, 21	PE
E90035	Valve, Foot, 3/8	11, 16, 21	VE
E90036	Valve, Foot, 1/2	31, 36	PE
E90037	Valve, Foot, 1/2	31, 36	VE
E90193	Valve, Foot, 1/2	31, 36	VF
E90234	Valve, Foot, 3/8	11, 16, 21	VF
E90239	Valve, Foot, 1/2	31, 36	TC
E90240	Valve, Foot, 3/8	11, 16, 21	TC
E90241	Valve, Foot, 3/8	11, 16, 21	FC
E90275	Valve, Foot, 1/2	31, 36	FC
E00001-00	Tubing, 1/2 OD LLDPE per foot	31, 36	all
E00001	Tubing, 1/2 OD LLDPE, 20 FT	31, 36	all
E00001-50	Tubing, 1/2 OD LLDPE, 50 FT	31, 36	all
E00001-100	Tubing, 1/2 OD LLDPE, 100 FT	31, 36	all
E00001-250	Tubing, 1/2 OD LLDPE, 250 FT	31, 36	all
E00001-500	Tubing, 1/2 OD LLDPE, 500 FT	31, 36	all
E00002-00	Tubing, 3/8 OD LLDPE per foot	11, 16, 21	all
E00002	Tubing, 3/8 OD LLDPE, 20 FT	11, 16, 21	all
E00002-50	Tubing, 3/8 OD LLDPE, 50 FT	11, 16, 21	all
E00002-100	Tubing, 3/8 OD LLDPE, 100 FT	11, 16, 21	all
E00002-250	Tubing, 3/8 OD LLDPE, 250 FT	11, 16, 21	all
E00002-500	Tubing, 3/8 OD LLDPE, 500 FT	11, 16, 21	all
E00071	Weight, Ceramic	all	all



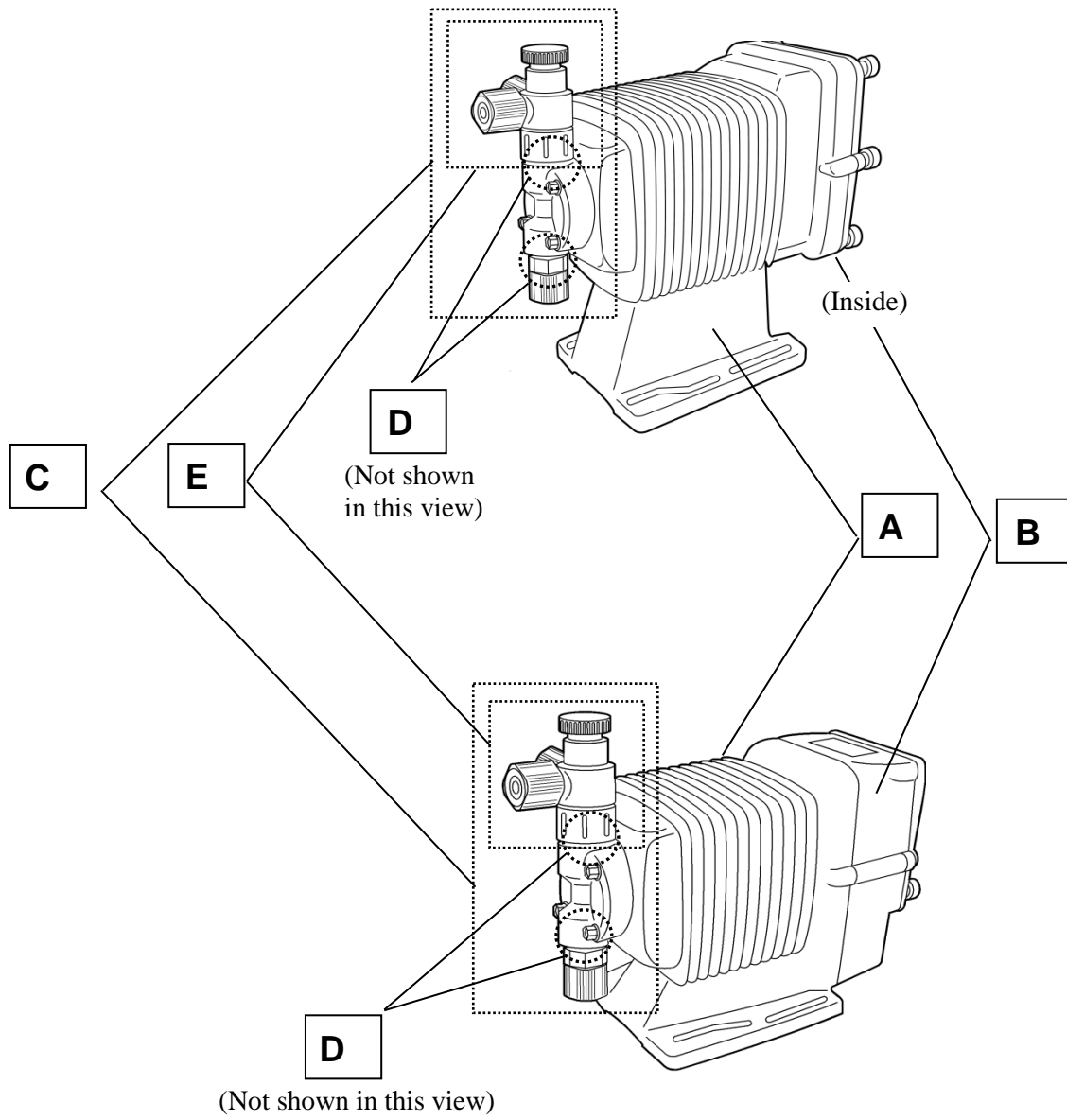

- A** Drive Unit
- B** Control Module
- C** Head Assembly
- D** Valve Cartridge
- E** Air Vent Assembly

Pump Model <sup>†</sup>	A Drive Unit <sup>†</sup>	B Control Module <sup>†</sup>	C Head Assembly * (Spare Parts Kit)						
			PC	PE	VC	VE	VF	TC	FC
EWB11F1-	WB11-1	EWBF1	X11PC (X11PC-PK)	X11PE (X11PE-PK)	X11VC (X11VC-PK)	X11VE (X11VE-PK)	X11VF (X11VF-PK)	X11TC (X11TC-PK)	X11FC (X11FC-PK)
EWB11F2-	WB11-2	EWBF2							
EWB16F1-	WB16-1	EWBF1	X16PC (X16PC-PK)	X16PE (X16PE-PK)	X16VC (X16VC-PK)	X16VE (X16VE-PK)	X16VF (X16VF-PK)	X16TC (X16TC-PK)	X16FC (X16FC-PK)
EWB16F2-	WB16-2	EWBF2							
EWB21F1-	WB21-1	EWBF1	X21PC (X21PC-PK)	X21PE (X21PE-PK)	X21VC (X21VC-PK)	X21VE (X21VE-PK)	X21VF (X21VF-PK)	X21TC (X21TC-PK)	X21FC (X21FC-PK)
EWB21F2-	WB21-2	EWBF2							
EWB31F1-	WB31-1	EWB30F1	X31PC (X31PC-PK)	X31PE (X31PE-PK)	X31VC (X31VC-PK)	X31VE (X31VE-PK)	X31VF (X31VF-PK)	X31TC (X31TC-PK)	X31FC (X31FC-PK)
EWB31F2-	WB31-2	EWBF2							
EWC16F1-	WC16-1	EWCF1	X16PC (X16PC-PK)	X16PE (X16PE-PK)	X16VC (X16VC-PK)	X16VE (X16VE-PK)	X16VF (X16VF-PK)	X16TC (X16TC-PK)	X16FC (X16FC-PK)
EWC16F2-	WC16-2	EWCF2							
EWC21F1-	WC21-1	EWCF1	X21PC (X21PC-PK)	X21PE (X21PE-PK)	X21VC (X21VC-PK)	X21VE (X21VE-PK)	X21VF (X21VF-PK)	X21TC (X21TC-PK)	X21FC (X21FC-PK)
EWC21F2-	WC21-2	EWCF2							
EWC31F1-	WC31-1	EWCF1	X31PC (X31PC-PK)	X31PE (X31PE-PK)	X31VC (X31VC-PK)	X31VE (X31VE-PK)	X31VF (X31VF-PK)	X31TC (X31TC-PK)	X31FC (X31FC-PK)
EWC31F2-	WC31-2	EWCF2							
EWC36F1-	WC36-1	EWCF1	X36PC (X36PC-PK)	X36PE (X36PE-PK)	X36VC (X36VC-PK)	X36VE (X36VE-PK)	X36VF (X36VF-PK)	X36TC (X36TC-PK)	X36FC (X36FC-PK)
EWC36F2-	WC36-2	EWCF2							
D Valve Cartridge	11	E90041	E90042	E90038	E90039	E90302	E90305	---	
	16, 21	E90048	E90049	E90045	E90046	E90303	---	---	
	31, 36	E90055	E90056	E90052	E90053	E90304	---	---	
E Manual Air Vent Valve Assembly	11, 16, 21	E90026	E90027	E90024	E90025	E90025	E90308	---	
	31, 36	E90248	E90249	E90246	E90247	E90247	E90250	---	
Automatic Air Vent Valve	11, 16, 21	---	---	E90023	---	---	---	---	
MultiFunction Valve Assembly	11, 16, 21	E90364	E90365	E90362	E90363	E90363	---	---	

Notes:

\* The P/N in the block is the head assembly part number and the spare parts kit is shown underneath in parentheses. For head assemblies with a Multifunction Valve, add an "M" to the end of the part number. Parts kits for pumps with Multifunction valves are the same as pumps without the "M" option. For head assemblies or parts kits with the Auto Air Vent Valve, add "A" after the "VC" code in the number.

† For EK pump models, change the "W" to "K" and the "F" to "R". The EK drive and control units are only sold as an assembly only. Use the Drive Unit number but change the "W" to "K" and add an "R" before the voltage code (i.e. KB11-R1). For EW pumps using a "Y" Control Module, change the "F" in the model number or part number to a "Y" to determine the correct Control Module part number.

## Drive and Control Module Exploded View

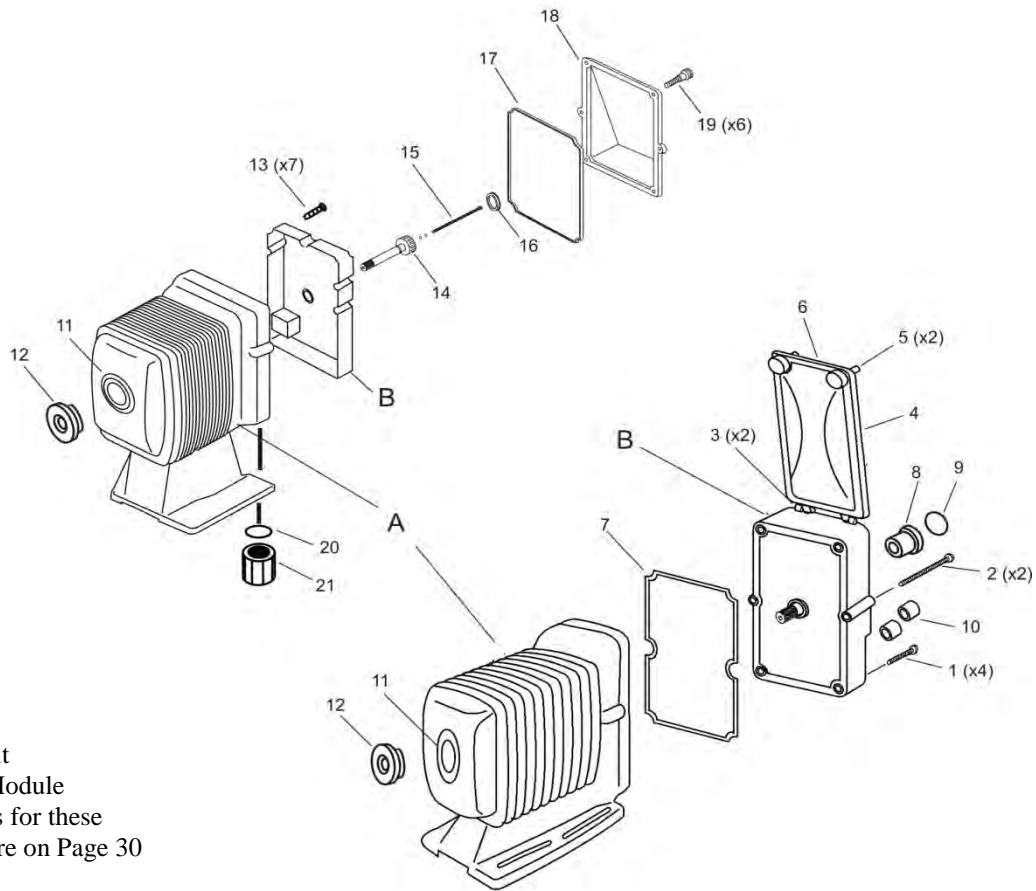

A Drive Unit  
 B Control Module  
 Part numbers for these  
 assemblies are on Page 30

Item	Part No.	Description	Series
1	EH1580	Screw, M5 x 55, SS PFH, Black	EW
2	EH1581	Screw, M5 x 47, SS PFH, Black	EW
3	EH1653	Hinge Pin, Spring, EW-F/Y Cover	EW
4	EH1646	Cover, Controller, Clear, EW-F/Y	EW
5	EH1648	Thumb Bolt, Captive, EW-F/Y, Cover	EW
6	EH1647	Gasket, Cover, EW-F/Y Controller, EPDM	EW
7	EH2427	Gasket, Controller-Drive, EW, EPDM	EW
8	EH1649	Knob, Stroke length, EW-F/Y	EW
9	EH1650	Label, EW-F/Y Stroke length knob	EW
10	EH1583	Cap, Mini din connector, EPDM	EW
11	EH1573	Gasket, Pump Head, EW/EK 11-21	EW, EK
	EH1574	Gasket, Pump Head, EW/EK 31	EW, EK
	EH1575	Gasket, Pump Head, EW/EK 36	EW, EK
12	EH1690	Spacer, Bracket, EW/EK/EZ-11	EW, EK
	EH1431	Spacer, Bracket, EW/EK/EZ-16	EW, EK
	EH1700	Spacer, Bracket, EW/EK/EZ-21	EW, EK
	EH1410	Screw, M4 x 10, SS PFH, Black	EK
14	EH1375	Knob, Stroke length, EK-B	EK-B
	EH1584	Knob, Stroke length, EK-C	EK-C
15	EH1376	Screw, SL Knob, EK-B, M4 x 95	EK-B
	EH1586	Screw, SL Knob, EK-C, M4 x 75	EK-C
	EH0141	Cap, Stroke length Adjustment Knob	EK
17	EH1372	Gasket, Cover, EK Controller, EPDM	EK
18	E90633	Cover Asm, EK Control Unit, (no bolts, w/gasket)	EK
	E90634	Cover Asm, EK Control Unit, (w/bolts & gasket)	EK
19	EH1374	Thumb Bolt, Captive, EK Cover	EK
20	EH1567	Gasket, Locknut, EK Input	EK
21	EH1565	Nut, Lock, Input connector, EK	EK

## 6.0 TROUBLESHOOTING

**CAUTION:** Before working on the pump, disconnect the power cord, depressurize the discharge tubing and drain or flush any residual liquid from the pump head and valves, using proper chemical handling techniques.

<b>Problem</b>	<b>Possible Cause</b>	<b>Corrective Action</b>
<i>Pump does not start</i>	Faulty wiring	Correct wiring
	Improper voltage	Connect to proper voltage source
	Electronic control unit is damaged	Replace control unit (Contact distributor or factory)
<i>Pump does not prime</i>	Air in suction tubing	Reroute suction tubing to eliminate air trap
	Valve gasket is not installed	Install valve gasket
	Valve set assembly direction is wrong.	Reassemble valve set
	Pump is air locked	Open air vent valve
	Suction or discharge valve is clogged with foreign matter	Disassemble, inspect, clean
	Ball stuck to valve seat	Disassemble, inspect, clean
<i>Output fluctuates</i>	Suction or discharge valve is clogged with foreign matter	Disassemble, inspect, clean
	Air is trapped in pump	Open air vent valve
	Overfeeding	Install injection valve or back pressure valve
	Diaphragm is damaged	Replace diaphragm
<i>Liquid leaks</i>	Fitting or coupling nut is loose	Re-install (see section 2.3/2.4)
	Pump head is loose	Tighten pump head bolts Torque: 19 lb-in (2.16 N-m)
	Diaphragm is damaged	Replace diaphragm
	O-ring or valve gasket missing	Install o-ring or valve gasket

## 7.0 SERVICE POLICY

The EW and EK Series electronic metering pumps have a 2-year limited warranty. Contact your Walchem distributor for service.