



**FLINT & WALLING**

Zoeller Family of Water Solutions™

# Installation Instructions and Parts Manual

## “CPJ” SERIES JET PUMPS

FW0427  
0712  
Supersedes  
0112

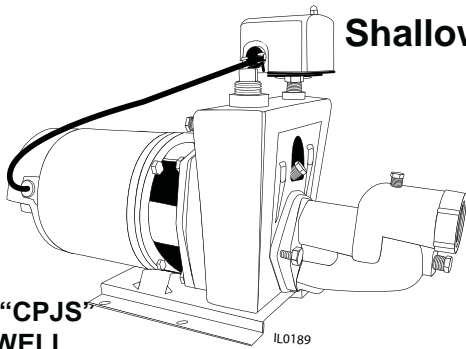

1/3 - 1/2 HP “CPJS”  
SHALLOW WELL

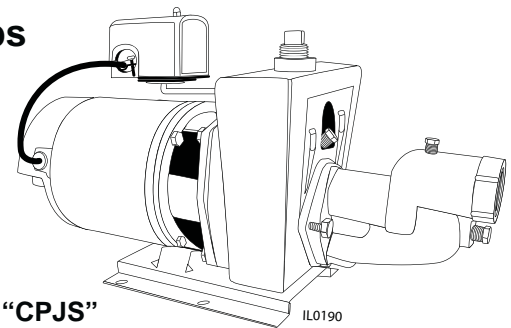

3/4 - 1-1/2 HP “CPJS”  
SHALLOW WELL

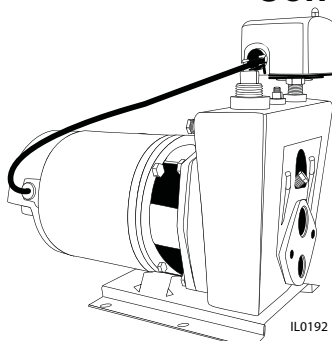

1/2 HP “CPJ”  
CONVERTIBLE

### Convertible Jet Pumps

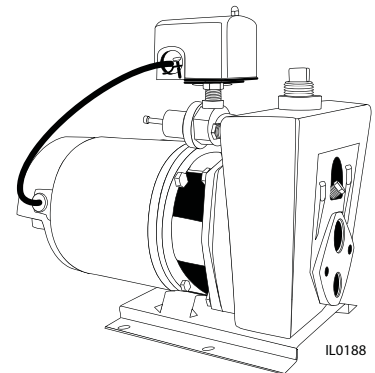

3/4 - 1-1/2 HP “CPJ”  
CONVERTIBLE

### Ejectors (Purchase separately)

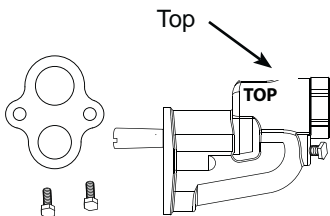

Shallow Well Ejector for lifts to 25  
ft.

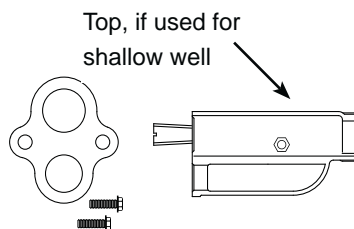

Convertible Ejector For Shallow  
or Deep well applications (4 inch  
inside diameter wells).



Single Pipe Deep Well  
Ejector (2 inch inside  
diameter wells).



**For loose, missing or damaged parts, or if the unit does not seem to be operating properly, please call before returning unit to the place of purchase**

**Phone: 1-800-742-5044**

**Service Hours:**

**Monday thru Friday - 7:30 am to 5:00 pm EST**

## SAFETY INFORMATION

### DANGER:

1. Always disconnect power source before performing any work on or near the motor or its connected load. If the power disconnect point is out-of-sight, lock it in the open position and tag it to prevent unexpected application of power. Failure to do so could result in fatal electrical shock.
2. Do not handle the pump with wet hands or when standing in water as fatal electrical shock could occur. Disconnect main power before handling unit for ANY REASON!
3. RISK OF ELECTRIC SHOCK. These pumps have not been investigated for use in swimming pool areas.

### WARNING:

1. Follow all local electrical and safety codes, as well as the National Electrical Code (NEC) and the Occupational Safety and Health Act (OSHA).
2. Replace damaged or worn wiring cord immediately.
3. Do not kink power cable and never allow the cable to come in contact with oil, grease, hot surfaces, or chemicals.
4. Wire motor to correct supply voltage - see motor nameplate and wiring diagrams and check voltage of power supply.
5. Unit must be securely and adequately electrically grounded. This can be accomplished by wiring the unit to a ground metal-clad raceway system or by using a separate ground wire connected to the bare metal of the motor frame or other suitable means.

6. This product contains chemicals known to the State of California to cause cancer and birth defects or other reproductive harm.
7. Hazardous Pressure! Install pressure relief valve in discharge pipe. Release all pressure on system before working on any component.
8. Do not use to pump flammable or explosive fluids such as gasoline, fuel oil, kerosene, etc. Do not use in flammable and/or explosive atmospheres.

### CAUTION:

1. Protect the power cable from coming in contact with sharp objects.
2. Be careful when touching the exterior of an operating motor - It may be hot enough to be painful or cause injury.
3. Make certain that the power source conforms to the requirements of your equipment.
4. Do not run pump dry.
5. Pump and plumbing must be full of water before startup.
6. Do not pump water which contains sand, mud, silt, or debris

NOTE: Pumps with the "UL" Mark and pumps with the "US" mark are tested to UL Standard UL778. CSA certified pumps are certified to CSA Standard C22.2 No. 108. (CUS)

## PRODUCT SPECIFICATIONS

### "CPJ" Series Pump & Motor Specifications

Chart 1

Pump Model No.	HP	Motor Voltage	Motor Wired For	Motor Max. Amps		Pressure Switch Setting PSI	Tapping Size (inches)		
				115V	230V		Discharge	Suction	Pressure
CPJ03SB	1/3	115/230*	115	8.6	4.3	30-50	3/4	1-1/4	-
CPJ05B	1/2	115/230*	115	13	6.5	30-50	3/4	1-1/4	1
CPJ05SB	1/2	115/230*	115	13	6.5	30-50	3/4	1-1/4	-
CPJ07B	3/4	115/230*	230	14	7	30-50	1	1-1/4	1
CPJ07SB	3/4	115/230*	230	14	7	30-50	1	1-1/4	-
CPJ10B	1	115/230*	230	18	9	30-50	1	1-1/4	1
CPJ10SB	1	115/230*	230	18	9	30-50	1	1-1/4	-
CPJ15B	1-1/2	115/230*	230	21	10.5	30-50	1	1-1/4	1
CPJ15SB	1-1/2	115/230*	230	21	10.5	30-50	1	1-1/4	-

All motors are single phase, 60 Hz., 3450 RPM.

Motors marked with \* are dual voltage and can be changed to either 115V or 230V by following the wiring diagram on motor decal.

# GENERAL PUMP INFORMATION

## Typical Pump Setup

Convertible jet pumps are designed for use in these applications:

1. Shallow wells (0 - 25 ft. lift) where ejector bolts to pump (Fig. 1)

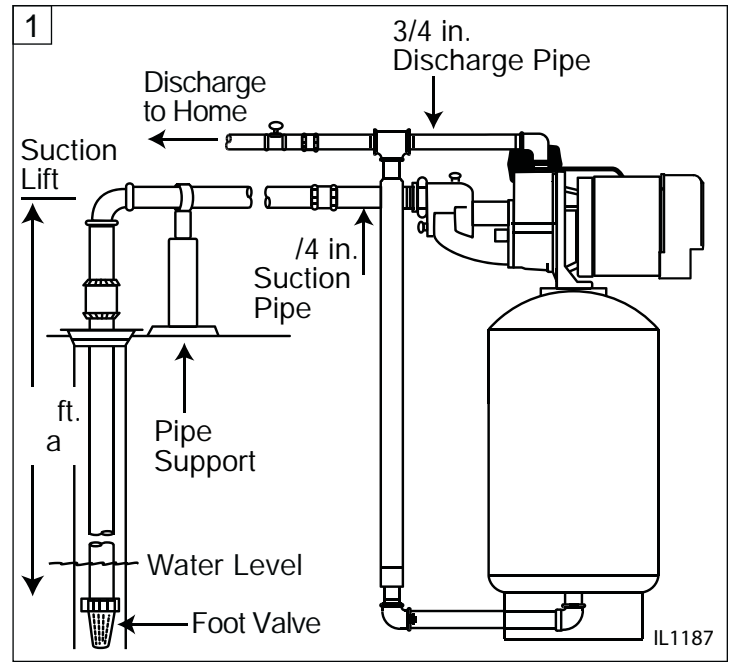

2. Deep wells where well ID is 4" or more and a two pipe ejector is installed in the well. (Fig. 2)

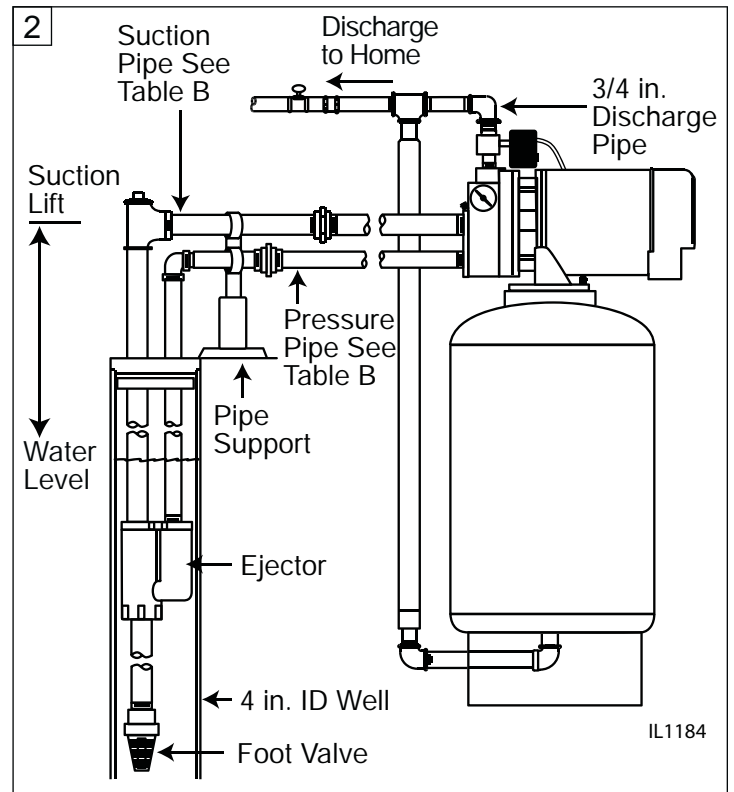

# GENERAL PUMP INFORMATION

3. Deep wells where well ID is 2" or more and a single pipe (packer) ejector is installed in the well. (Fig. 3)

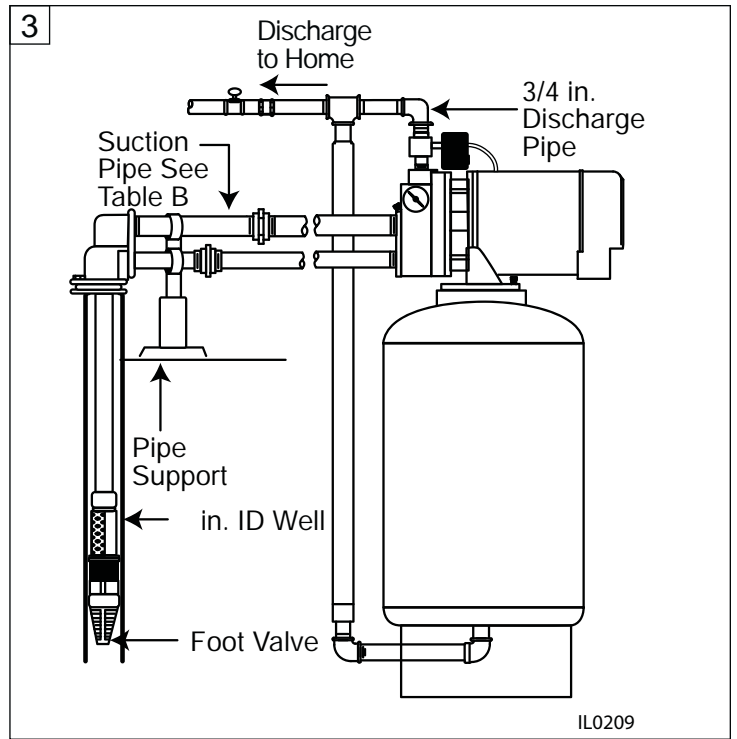

4. CPJ Convertible 3/4 - 1-1/2 HP (Fig. 4)

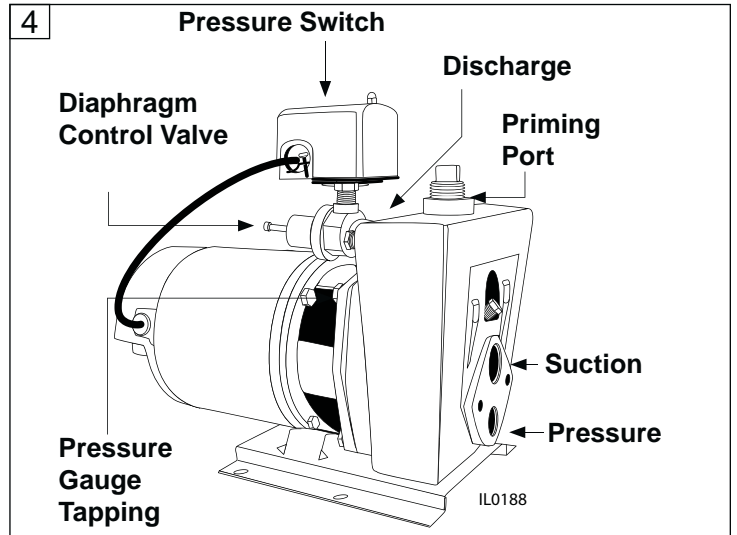

5. CPJ Convertible 1/2 HP (Fig. 5)

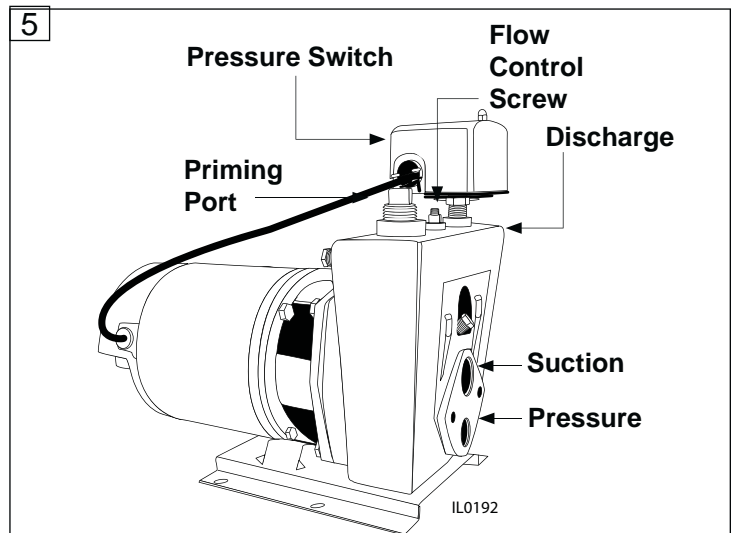

## GENERAL PUMP INFORMATION

### 6. CPJ Shallow Well 1/3 - 1/2 HP (Fig. 6)

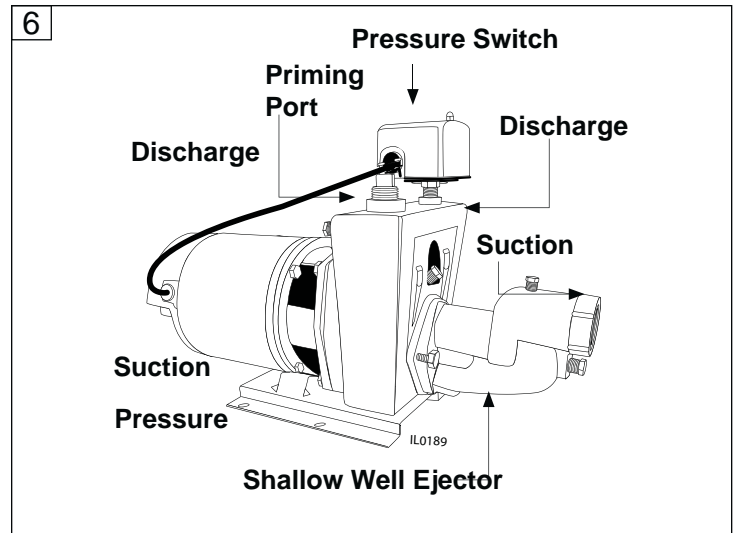

#### **Ventilation**

Ventilation and drainage must be provided to prevent damage to the motor from heat and moisture.

#### **Freezing**

The pump and all piping must be protected from freezing. If freezing weather is forecast, drain pump or remove completely from the system.

#### **Water Supply**

The water source must be able to supply enough water to satisfy the capacity of the pump and water needs.

#### **Suction Lift**

Suction lift is the vertical distance from the lowest level of the water to the pump intake. See performance charts on page 2 and 3 to determine how far your pump can lift water.

#### **Horizontal Distance**

The horizontal distance is the horizontal measurement between the pump suction and the water source. This distance may affect the ability of the pump to operate. If it is over 100 feet, call the manufacturer for assistance at 1-800-742-5044.

#### **Pipe And Fittings**

Use galvanized steel or NSF PW Schedule 40 PVC pipe and fittings. This material is designed for water pressure and will seal against air and water under pressure. Do Not Use: DWV fittings, as these are designed for drains without pressure and will not seal properly. (Fig. 1, 2 & 3)

**⚠ CAUTION:** The entire system must be air and water tight for efficient operation and to maintain prime.

#### **Wire Size:**

The wire size is determined by the distance from the power source to the pump motor, and the horsepower rating of the motor. See the wire chart for proper wire size.

### WIRE SIZE CHART

### CHART 2

Recommended Copper Wire and Fuse Sizes					
	HP Rating of Single Phase Motors				
Distance from Motor to Meter	1/3	1/2	3/4	1	1-1/2
0-50'					
115V	14 GA	12 GA	12 GA	10 GA	10 GA
230V	14 GA	14 GA	14 GA	14 GA	12 GA
50-100'					
115V	14 GA	12 GA	12 GA	10 GA	8 GA
230V	14 GA	14 GA	14 GA	14 GA	12 GA
100-150'					
115V	14 GA	12 GA	10 GA	10 GA	6 GA
230V	14 GA	14 GA	14 GA	12 GA	12 GA
150-200'					
115V	12 GA	12 GA	10 GA	8 GA	*
230V	14 GA	14 GA	12 GA	12 GA	10 GA
200-300'					
115V	12 GA	10 GA	8 GA	6 GA	*
230V	14 GA	14 GA	12 GA	10 GA	10 GA
Fuse Size	Amps	Amps	Amps	Amps	Amps
115V	15	20	20	30	30
230V	15	15	15	15	20

\*Not economical to run in 115V. Use 230V.

# PREPARATION

Before beginning installation of product, make sure all parts are present. If any part is missing or damaged, do not attempt to assemble the product. Contact customer service for replacement parts.

Estimated Installation Time: 2 hours.

## Tools required

- |                      |                   |
|----------------------|-------------------|
| Pipe wrenches (2)    | Wire cutters      |
| Wire strippers       | Adjustable wrench |
| Needle-nose pliers   | Pipe tape         |
| Phillips screwdriver | Pipe dope         |

**NOTE:** For a successful installation, take time to study your application for the correct pipe size and appropriate fittings. The illustrations in these instructions will assist you with required and optional fittings. Sch. 40 PVC plastic pipe and fittings were used in these instructions.

Item	Description
1	1-1/4 in. union
2	1-1/4 in. adapter
3	1-1/4 in. elbow
4	3/4 in. union
5	1 in. adapter
6	1 in. x 3/4 in. reducer bushing
7	3/4 in. adapter
8	1 in. elbow
9	1-1/4 in. check valve
10	3/4 in. tee (plastic)
11	3/4 in. tee (steel)
12	3/4 in. x 3 in. nipple (steel)
13	3/4 in. plug (steel)
14	Foot valve
	Electric cord strain relief
	134349 Flow control package

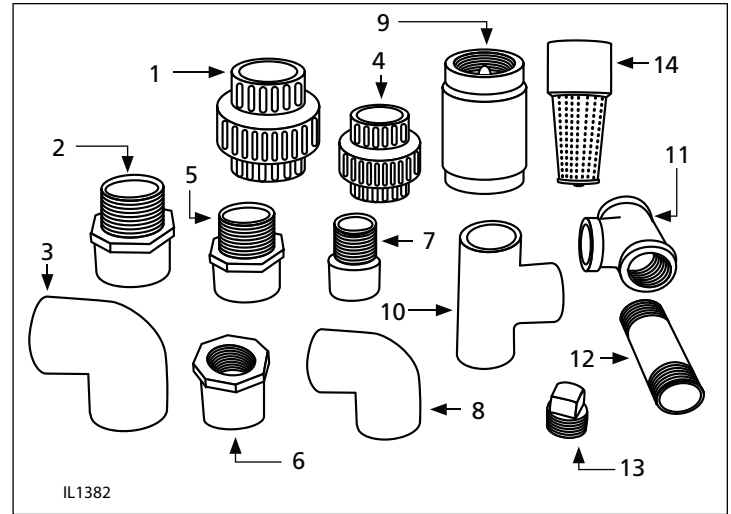

OPTIONAL PARTS FOR ASSEMBLY		CHART 4
(not included) (Fig 2)		
Item	Description	
1	Ball Valve (plastic)	
2	3/4 in. x 1/4 in. bushing (steel)	
3	Pressure Gauge	
4	Pump stand for tank	
5	Well adapter for single pipe packer installations (straight and right angle shown)	

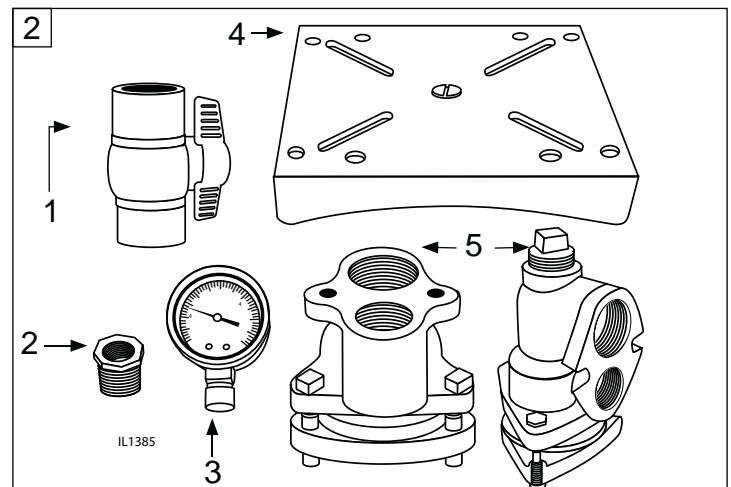

# INSTALLING PIPING IN WELL

## Shallow Well Application

- Where Suction Lift Is Less Than 25 Feet

On single pipe installations (Fig. 1) attach foot valve to the end of the suction pipe and set in the well, making certain the valve is below the water level. The foot valve should be at least five (5) feet from the bottom of the well to prevent sand from being drawn into the system.

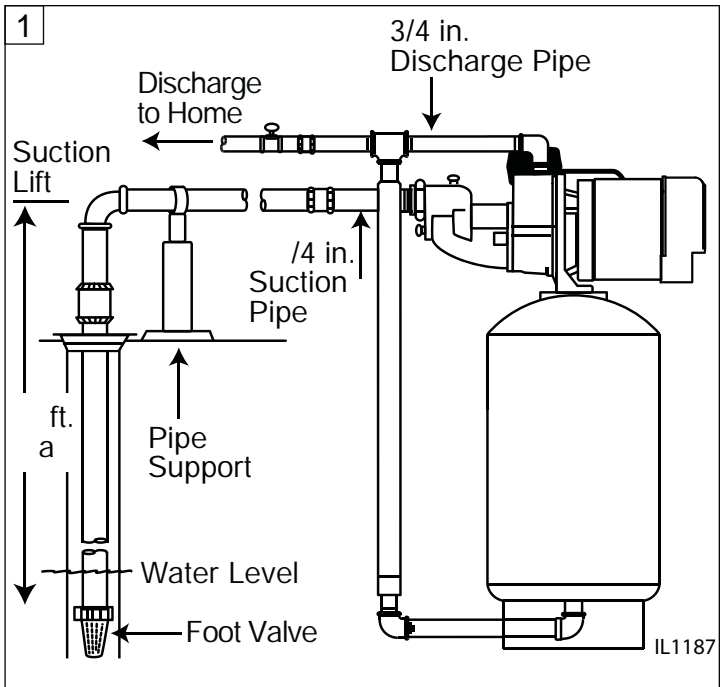

When connecting a drive point (Fig. 2) a check valve must be used in the suction line in place of a foot valve. For easy priming connect the check valve as close to the well as possible.

All piping from the well to the pump should slope slightly upward with no sagging. Support suction pipe between water source and pump. Unions in the suction line near the pump and well will aid in servicing. Be sure to leave enough room so that wrenches can be used easily.

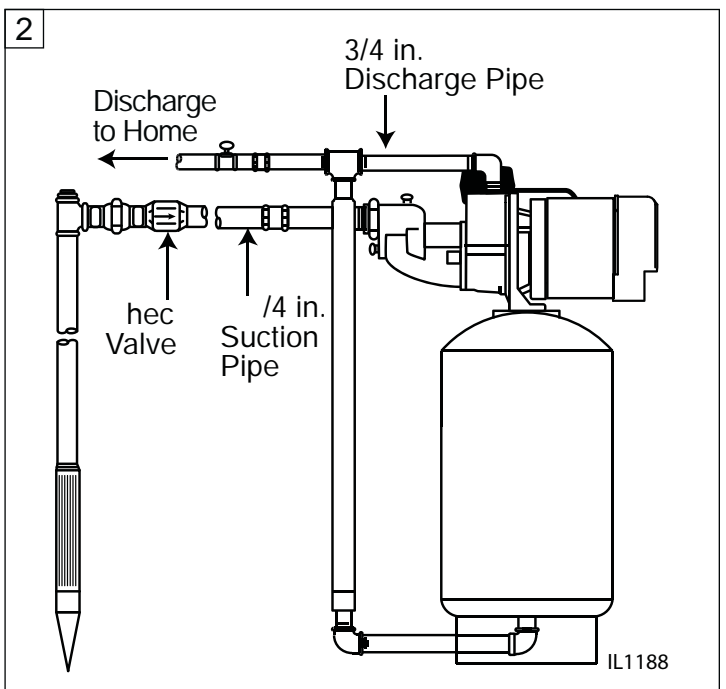

## RECOMMENDED SUCTION PIPE SIZES FOR SHALLOW WELL PUMP

## CHART 5

Motor HP	Vertical Piping Size	Length of Offset from Well			
		0-20'	20-100'	100-200'	200-400'
1/3	1"	1"	1-1/4"	1-1/2"	2"
1/2	1"	1"	1-1/2"	1-1/2"	2"
3/4	1-1/4"	1-1/4"	1-1/2"	2"	2"
1	1-1/4"	1-1/4"	1-1/2"	2"	2"
1-1/2	1-1/4"	1-1/4"	1-1/2"	2"	2"

# INSTALLING PIPING IN WELL

## Deep Well (Double Pipe System)

Where water level is greater than 25 feet and inside diameter of well is four (4) inches or larger (Fig. 1).

1. Attach the foot valve to the ejector using a galvanized steel or plastic nipple. Add enough 1 in. pressure pipe and 1-1/4 in suction pipe to submerge ejector 10 to 15' below pumping water level, making certain foot valve is at least five (5) feet from bottom of well. If pressure pipe and suction pipe of the same diameter are used, be sure to identify them clearly so that they will be connected to the proper tappings of the pump.

If a known well leak exists, replace nipple with 21 feet of 1" tail pipe between the ejector and the foot valve. This will provide a continuous source of water for the pumping system.

2. Check pipe and foot valve for leaks by filling pipes with water. A continuous loss of water indicates a leak in the piping, foot valve or unions, and must be corrected.
3. If no leaks are found, proceed to **WELL TO PUMP CONNECTION (SUCTION PIPE)**. For long offset distances, see Table B for proper pipe size.
4. All piping from the well to the pump should slope slightly upward with no sagging. Support suction pipe between water source and pump. Unions in the suction line near the pump and well will aid in servicing. Be sure to leave enough room so that wrenches can be used easily.

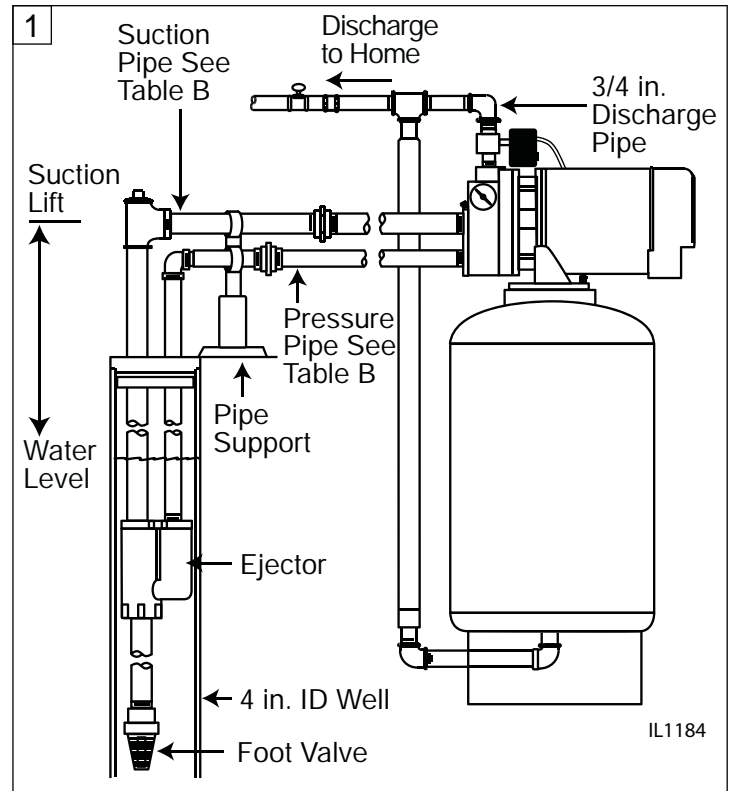

**PIPE SIZES REQUIRED FOR OFFSET PIPING FOR DEEP WELL EJECTOR INSTALLATION TABLE B**

Distance Well to Pump	1/3 HP		1/2 HP		3/4 HP		1 & 1-1/2 HP	
	Suc.	Press.	Suc.	Press.	Suc.	Press.	Suc.	Press.
0-25'	1-1/4"	1"	1-1/4"	1"	1-1/4"	1"	1-1/4"	1"
25-50'	1-1/4"	1"	1-1/4"	1-1/4"	1-1/2"	1-1/4"	1-1/2"	1-1/4"
50-75'	1-1/4"	1-1/4"	1-1/4"	1-1/4"	1-1/2"	1-1/2"	1-1/2"	1-1/2"
75-100'	1-1/2"	1-1/4"	1-1/2"	1-1/4"	1-1/2"	1-1/2"	2"	1-1/2"
100-150'	1-1/2"	1-1/4"	1-1/2"	1-1/2"	2"	1-1/2"	2"	2"



## INSTALLING PIPING IN WELL

### Deep Well (Single Pipe System)

Application - Where pumping water level is greater than 25 feet and inside diameter of well is 2, 2-1/2 or 3 inches. (Fig 1)

On single pipe deep well installations, clean, sound well casing must be used to give a tight seal.

NOTE: This application requires a well adapter for the top of the well.

NOTE: Pre-soak packer leathers for approximately two hours before installation.

1. Attach foot valve directly to bottom of ejector assembly. Ejector must be submerged 10 to 15 feet below pumping water level and the foot valve must be at least five (5) feet from bottom of well.
2. Attach foot valve and packer ejector to suction pipe (pre-soak packer leathers for approximately two (2) hours). Push the assembly down the well. Some force may be required to push the ejector down the casing.
3. As each section is lowered, check for leaks by pouring water into the suction pipe.
4. Attach well adapter to suction pipe, lower over casing top and tighten adapter flange.
5. If no leaks are found, proceed to **WELL TO PUMP CONNECTION (SUCTION PIPE)** using piping of the same diameter as the suction pipe (1-1/4") and pressure pipe (1") tapings of the pump. For long offset distances, see Table B for the proper pipe size.
6. Unions in suction and discharge piping near pump and well will aid in servicing. Be sure to leave enough surrounding room so that wrenches can be used easily.

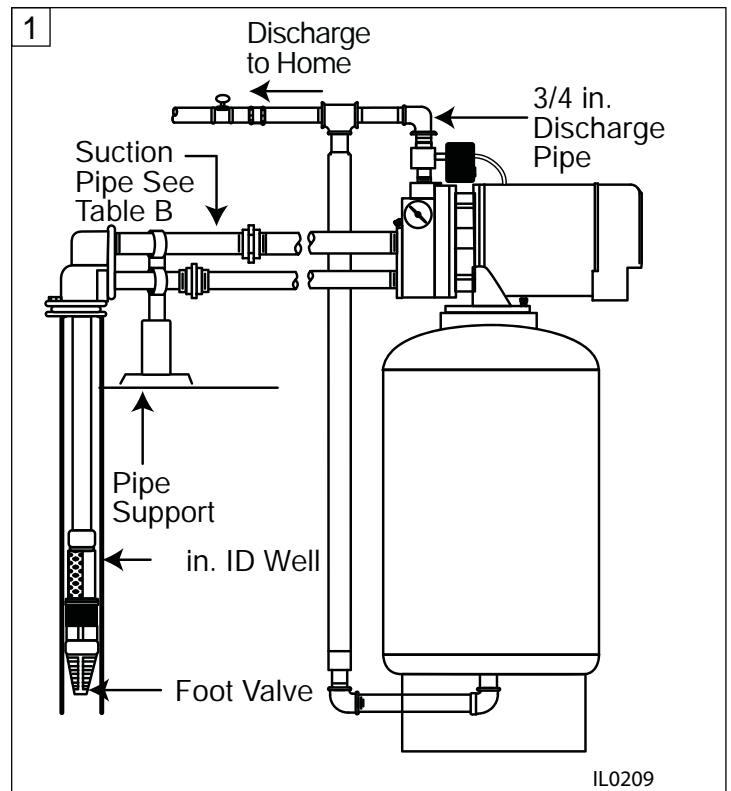

## WELL TO PUMP CONNECTION (SUCTION PIPE)

1. Attach ejector to face of pump with two (2) bolts and gasket provided. Venturi tube on the ejector inserts into the top tapping of the face of the pump (Fig. 1).

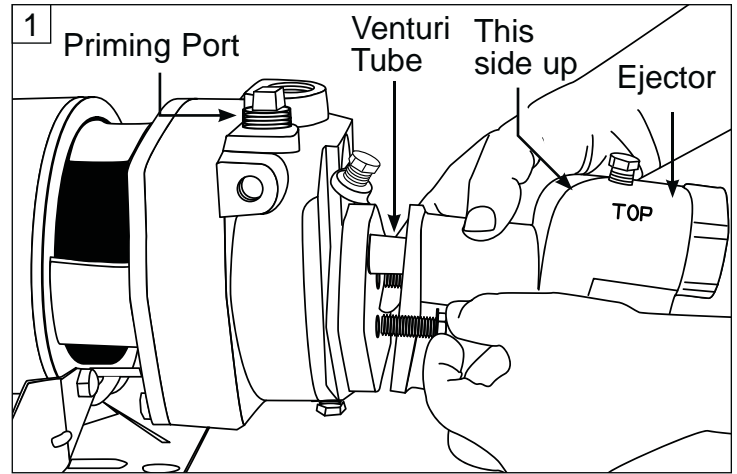

2. Make the connection to your well. Wrap all threaded fittings with pipe tape 5 times or apply a pipe paste (pipe dope) to ensure an air tight connection. (Fig. 2)

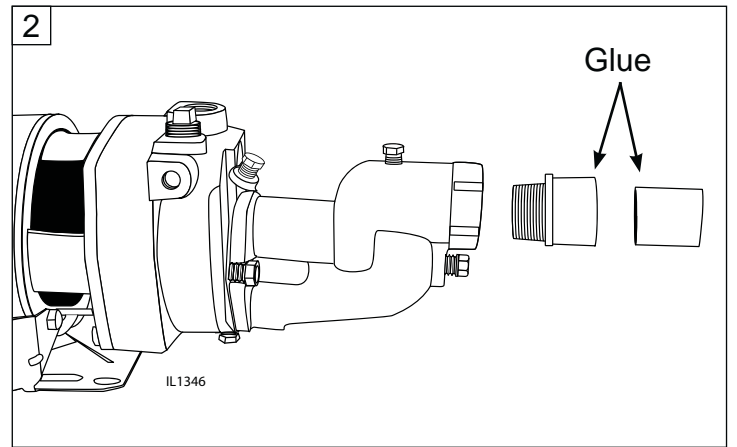

3. The use of a union (optional) will assist with easy connection and disconnect. (Fig. 3)

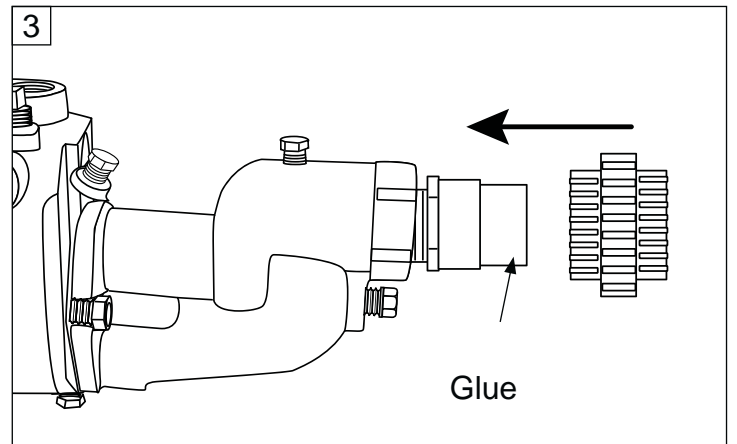

4a. NOTE: For drilled (cased) wells, a foot valve is required in the well at the end of the pipe to maintain prime. (Fig 4a)

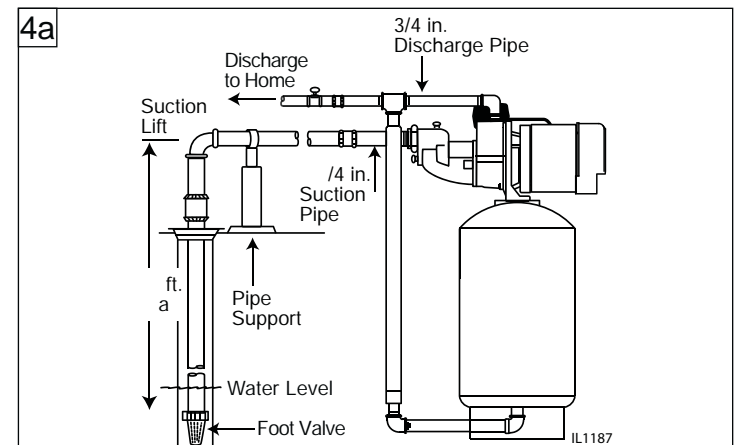

## WELL TO PUMP CONNECTION (SUCTION PIPE)

- 4b. For driven wells, a check valve is required at the top of the well to maintain prime. Flow arrow must point toward pump. (Fig. 4b)

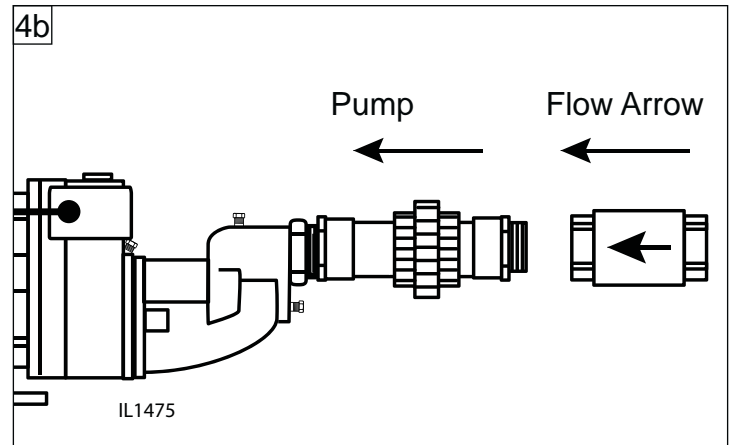

5. Finish the connection to your well with additional pipe and fittings as needed. (Fig. 5)

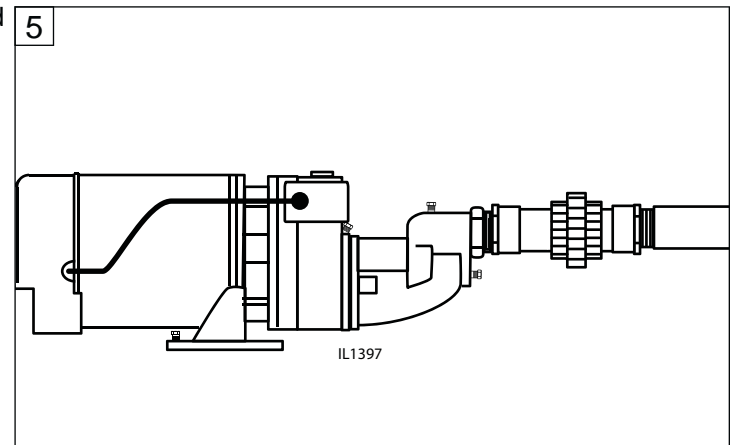

### Deep Well Application Only:

1. Make the connection to your well. Wrap all threaded fittings with pipe tape 5 times or apply a pipe paste (pipe dope) to ensure an air tight connection. (Fig. 1)

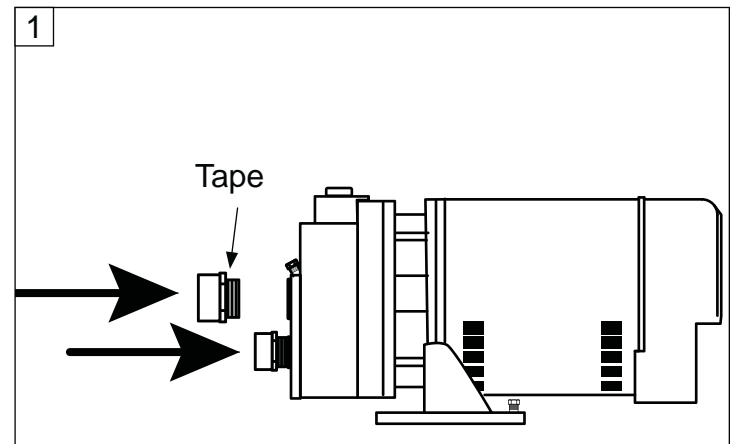

2. Finish the connection to your well with additional pipe and fittings as needed. (Fig. 2)

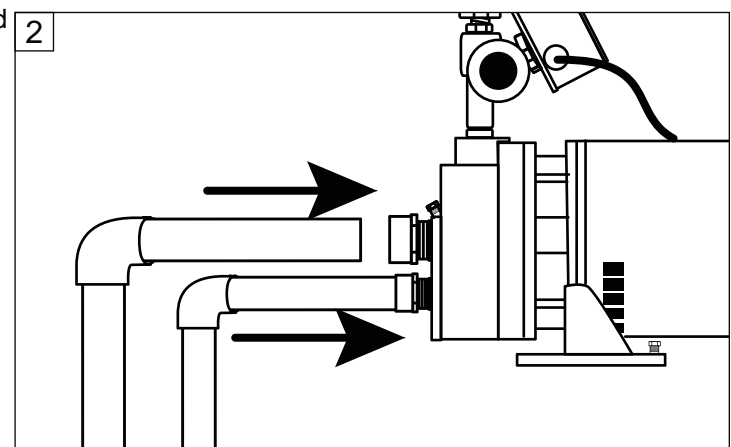

## PUMP TO PRESSURE TANK CONNECTION (DISCHARGE PIPE)

### **Shallow Well Application Only:**

1. Begin the connection to the pressure tank. Using a 3/4 in. x 3 in. galvanized nipple, wrap the threads 5 times with pipe tape and apply pipe paste (pipe dope) and install in top of pump. (Fig. 1)

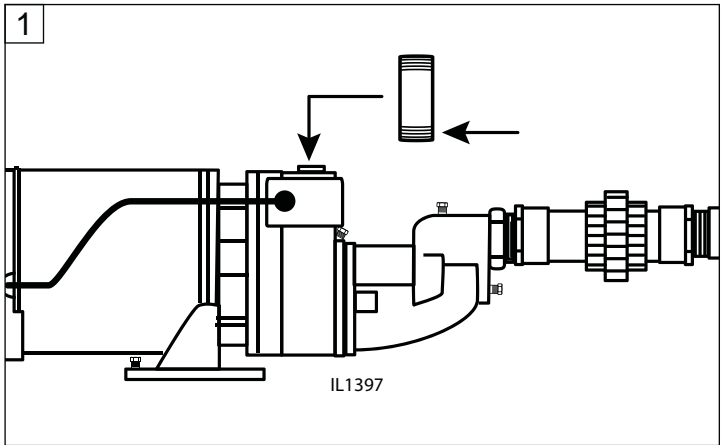

2. Install a 3/4 x 3/4 x 3/4 in. galvanized tee fitting. (Fig. 2)

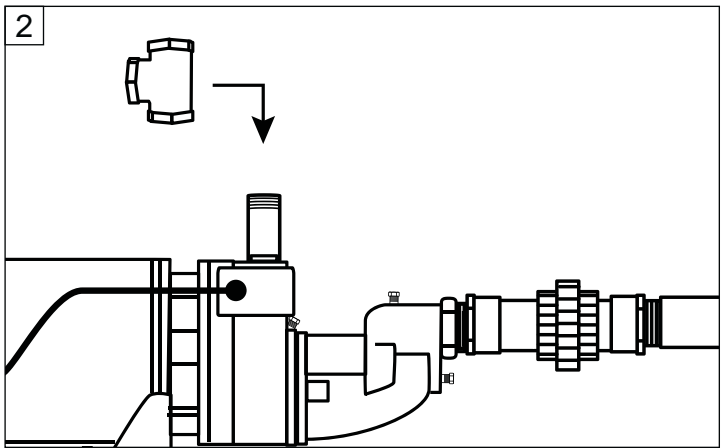

3. Install a 3/4 in. MPT x 1/4 in. FPT galvanized bushing and pressure gauge (optional), or a pipe plug. Do not tighten, as you will prime your pump later at this location. (Fig. 3)

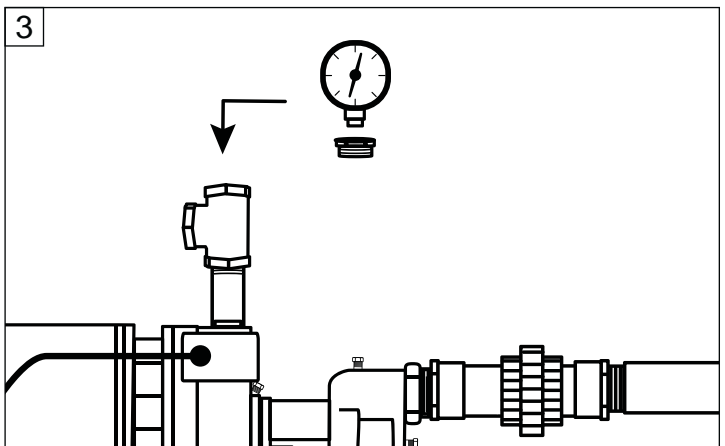

4. Continue with fittings and pipe to the pressure tank. A 3/4 in. union (optional) for easy connection and disconnection. (Fig. 4)

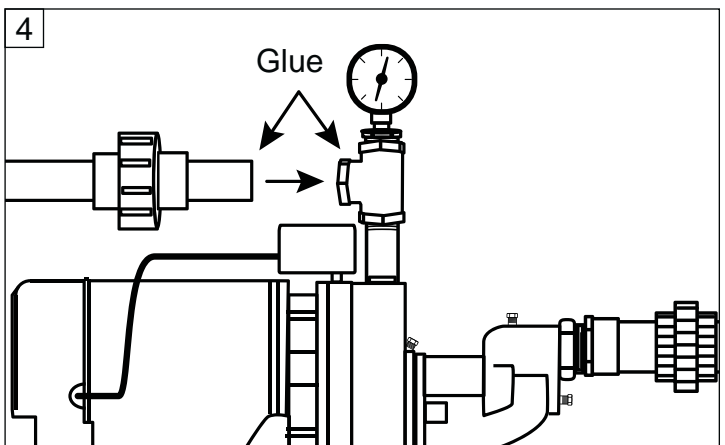

## PUMP TO PRESSURE TANK CONNECTION (DISCHARGE PIPE)

### Deep Well Application Only:

1. To begin the connection to the pressure tank, loosely assemble flow control body to pump head. Using Teflon tape, position the discharge outlet of the control body facing right as you look directly into the face of the pump

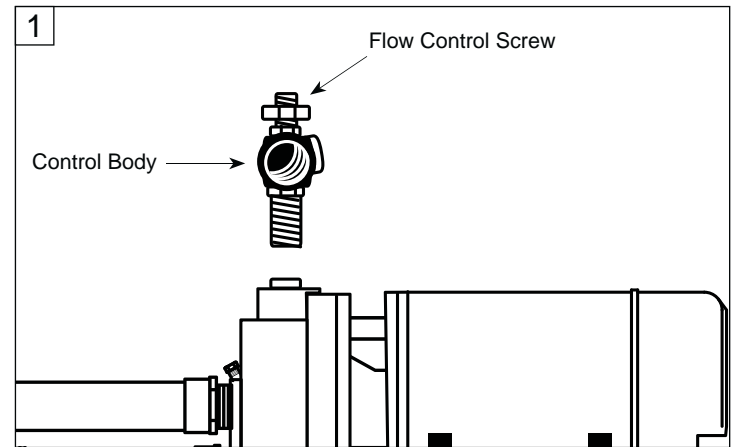

2. Assemble the pressure switch in the 1/4" tapping adjacent and to the right of the discharge outlet of the control valve (Fig. 2). Refer to Pump Electrical Connection section for pressure switch wiring.

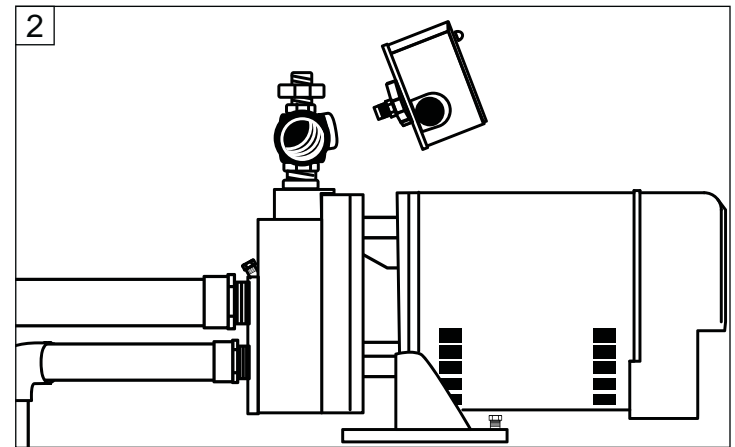

3. Tighten flow control body. (Fig. 3)

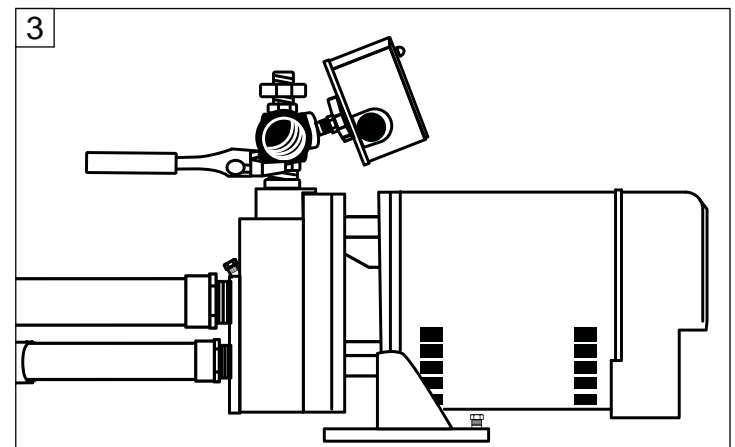

4. Install optional pressure gauge in 1/4" tapping on side of pump body. Face of gauge should be positioned so that dial can be read easily (Fig. 4).

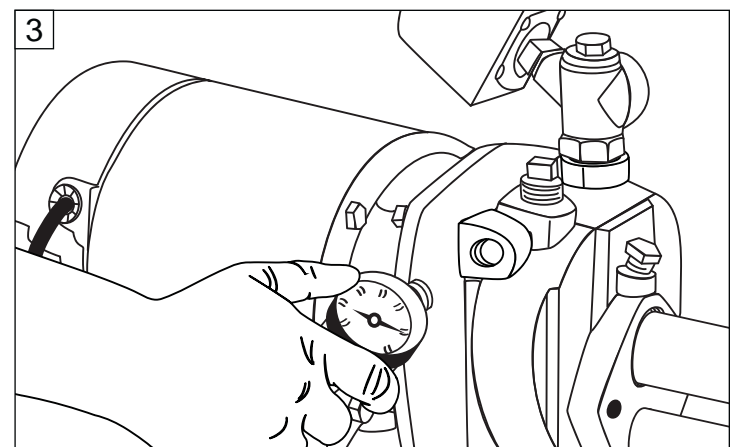

## **PUMP TO PRESSURE TANK CONNECTION (DISCHARGE PIPE)**

5. Continue with fittings and pipe to the pressure tank.  
A 3/4 in. union is optional but recommended for easy connection and disconnection. **(Fig. 5)**  
**CAUTION:** Install a pressure relief valve on any installation where the pump pressure can exceed the maximum working pressure of the tank.

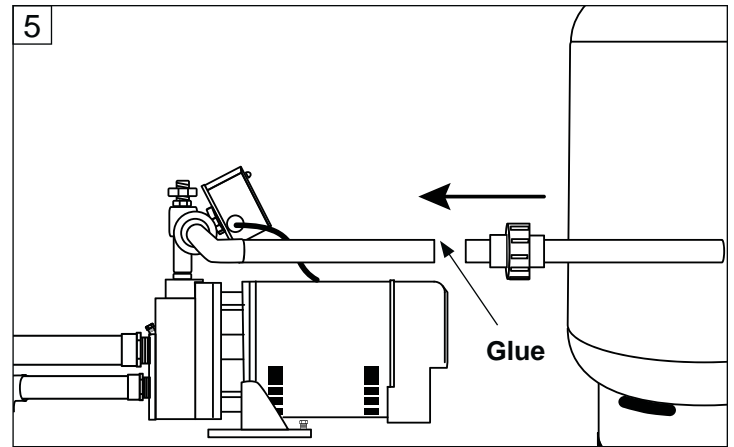

## **TANK TO HOUSE CONNECTION**

1. Most pressure tanks will have a 1 inch inlet elbow on the bottom. Connect to this elbow with a 1 in. MPT x 1 in. slip (glue) adapter and short piece of pipe. **(Fig 1)**

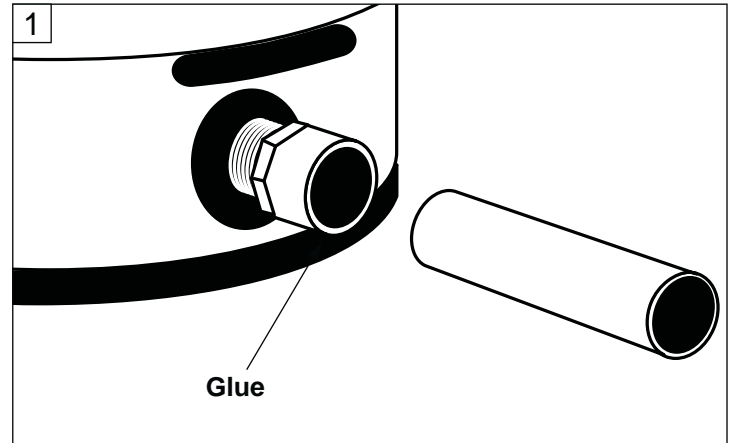

2. Install a 1 in. elbow. **(Fig. 2)**

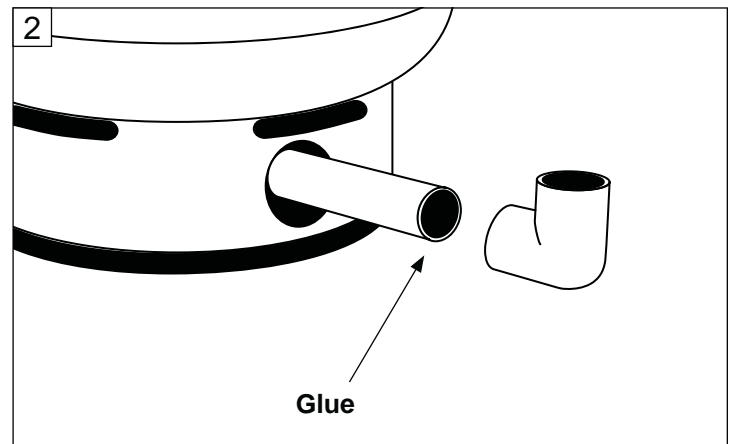

# TANK TO HOUSE CONNECTION

3. Attach a 1 in. slip (glue) x 3/4 in. FPT adapter and 3/4 in. MPT x 3/4 in. slip. (**Fig. 3**)

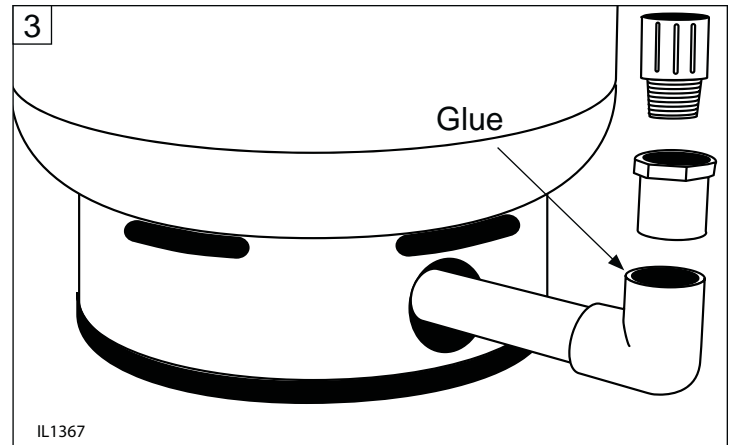

4. Install a 3/4 in. union (optional) and continue with pipe and 3/4 in. x 3/4 in. x 3/4 in. tee. (**Fig. 4**)

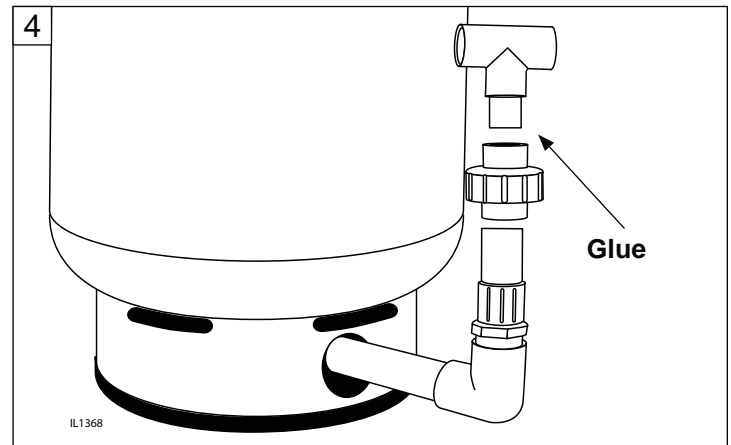

5. Make the connection to the house plumbing. From the tee, install pipe and shut off valve (optional). (**Fig 5**)

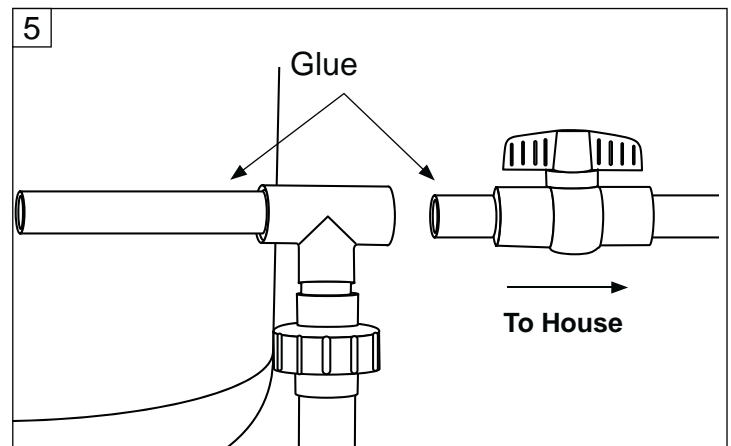

6. Completed installation with piping and tank is shown (**Fig. 6**)

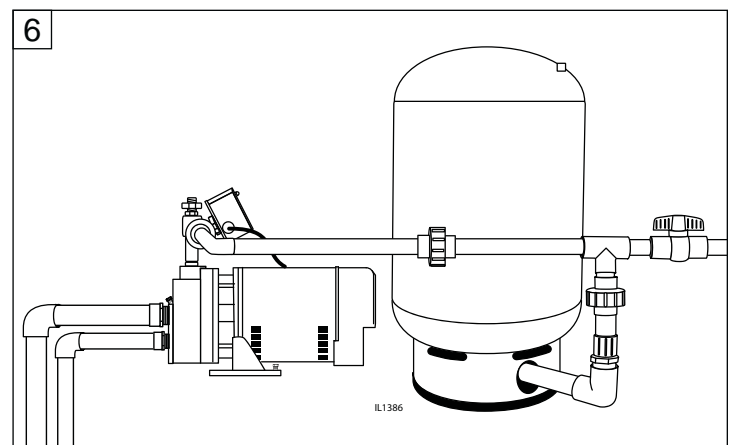

# PUMP ELECTRICAL CONNECTIONS

**CAUTION:** All wiring should be performed by a qualified electrician in accordance with the National Electric Code and local electric codes.

**CAUTION:** Connect the pump to a separate electrical circuit with a dedicated circuit breaker. Refer to the Wire Size Chart for proper fuse size.

**WARNING:** Under-size wiring can cause motor failure and even fire. Use proper wire size specified in the Wire size chart.

**WARNING:** Replace damaged or worn wiring cord immediately.

**WARNING:** Do not kink power cable and never allow the cable to come in contact with oil, grease, hot surfaces, or chemicals.

**CAUTION:** Protect the power cable from coming in contact with sharp objects.

**CAUTION:** Make certain that the power source matches the pump requirements. This pump has a dual voltage motor and can run on 115V or 230V. See page 20. 1/2 HP pumps are wired from the factory to run on 115V. 3/4 & 1 HP pumps are wired from the factory to run at 230V.

**WARNING:** The pump must be properly grounded using the proper wire cable with ground.

**WARNING:** Always disconnect pump from electricity before performing any work on the motor.

## Wiring The Pressure Switch

1. **CAUTION:** Make certain that the power source matches the pump requirements. This pump has a dual voltage motor and can be wired by the customer to run on 115V or 230V. (Fig. 1)

NOTE: To change pump voltage, see wiring diagram on this page or step-by-step instructions on page 18.

2. Screw the pressure switch into the 1/4 in. opening on the side of the flow control and remove the switch cover. (Fig. 2)

## WIRING DIAGRAM

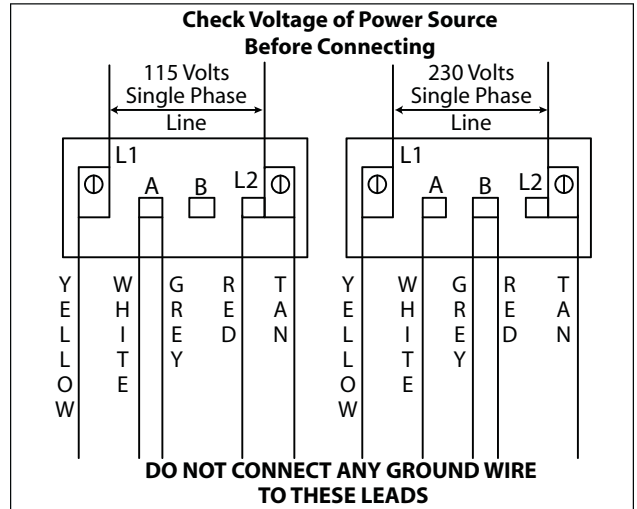

1	Motor:	<b>96L105</b>				
	HP:	1/2	PH	1	Hz	60
	Volts	115/230	S.F.	1.2	Amps	6.4/3.2
	S.F. Amps:	8.6/4.3	RPM	3450	Type	C
	Duty:	Cont.	Temp	65C	KVA Code	G
	Frame	56L	Ins Class	B		
	Factory prewired for 115V			Thermally protected automatic		
	Check voltage of power source			Use copper conductors only		
	<b>ELECTRICAL HAZARD</b>					
	Improper installation may result in fire, explosion, electrical short or injury. Replace all covers before operating. Ground motor in accordance with local and national electrical codes. Disconnect power source before touching internal parts. Motors equipped with automatic protection may restart without warning. See instruction manual for proper installation procedure. Se reporter au manuel d'instructions pour suivre la procédure adéquate d'installation. Consulte el instructivo para conocer el procedimiento de instalación correcto.					

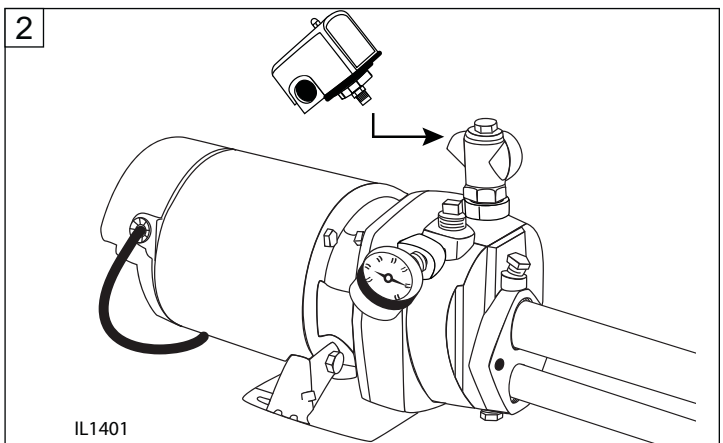



## PUMP ELECTRICAL CONNECTIONS

3. Insert an electrical wire strain relief into the opening in the side of the pressure switch closest to the motor. (Fig. 3)

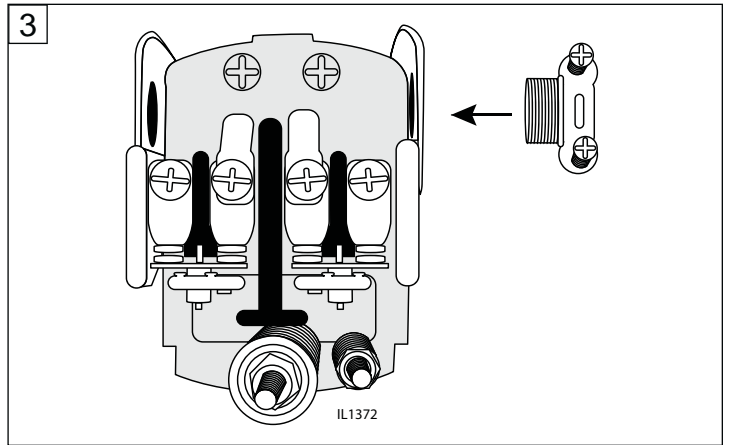

4. Thread the cable from the pump motor through the strain relief into the pressure switch cavity and tighten both screws on the strain relief. Do not crush wire. (Fig. 4)

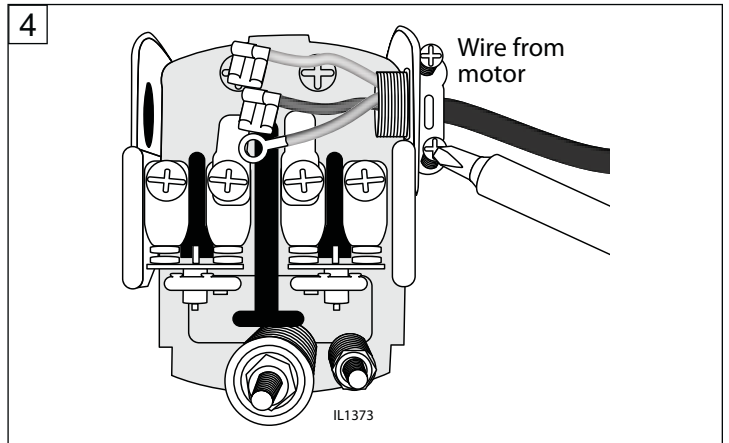

5. Connect the two motor wires of the motor cable to the two inside terminals on the pressure switch. (Fig. 5)

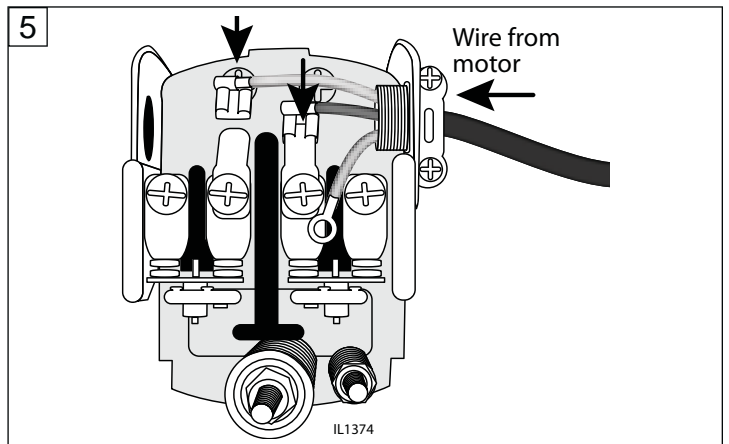

6. Connect the green ground wire from the motor cable to one of the green ground screws at the bottom of the pressure switch. (Fig. 6)

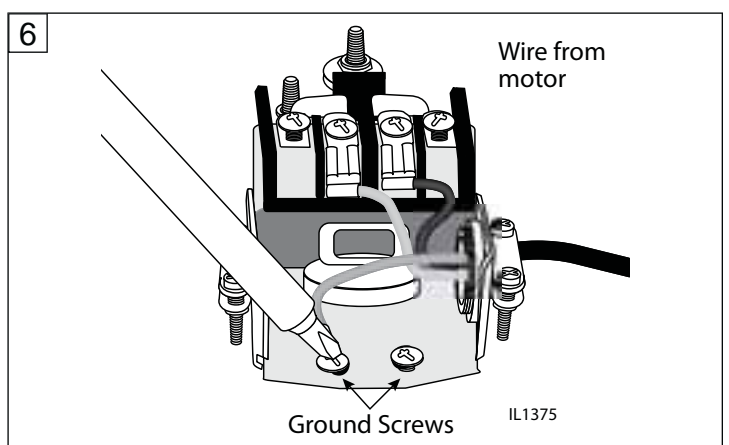

## PUMP ELECTRICAL CONNECTIONS

7. Insert an electrical wire strain relief into the opening in the opposite side of the pressure switch. (**Fig. 7**)

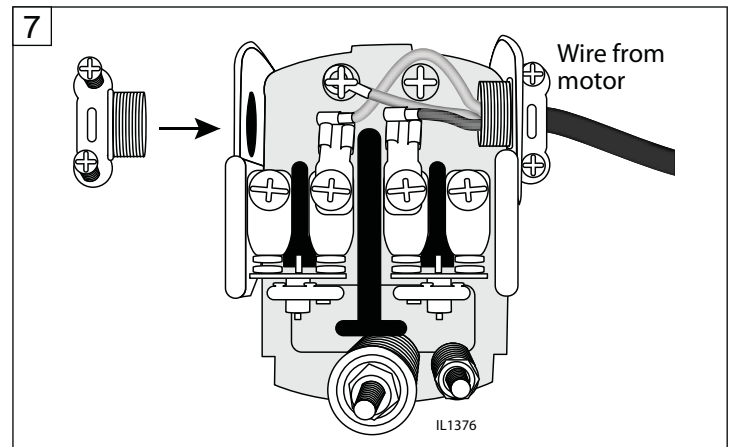

8. Thread the cable from the power supply through the strain relief and tighten both screws on the strain relief. Do not crush wire. (**Fig. 8**)

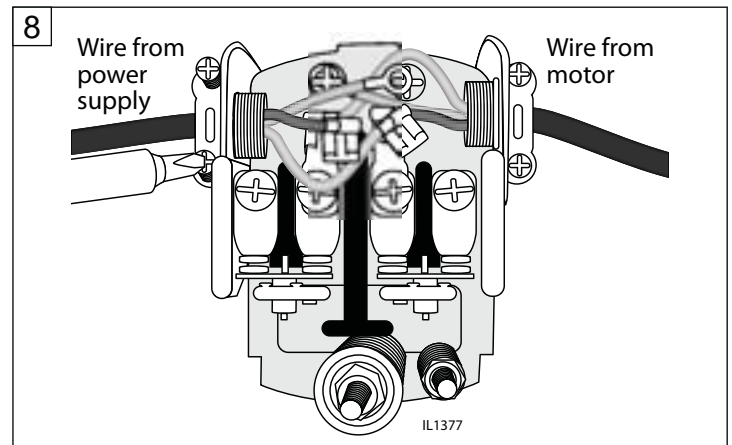

9. Connect the two wires from the power supply to the two outside terminals on the pressure switch. (**Fig. 9**)

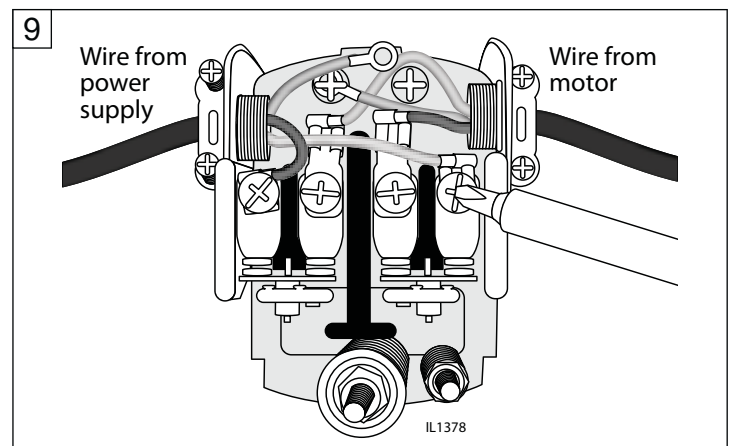

10. Connect the green ground wire from the power supply to the remaining green ground screw in the pressure switch and re-attach the pressure switch cover. (**Fig. 10**)

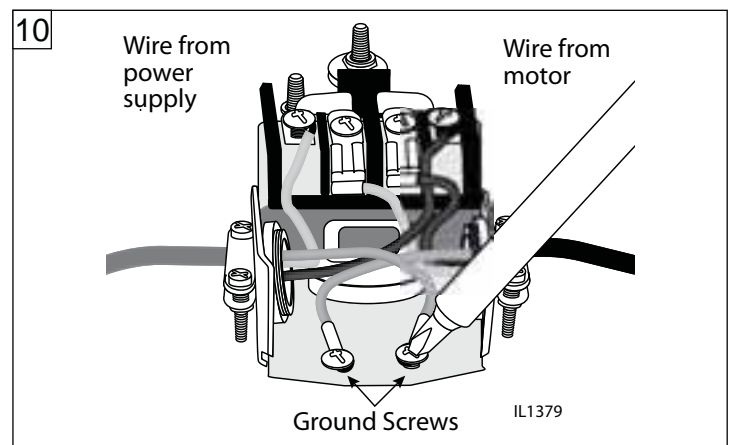

# PUMP ELECTRICAL CONNECTIONS

## To change from 115V to 230V

11. The motor of this pump is dual voltage and can run on either 115V or 230V. In general, 230V is more economical to run, and requires a smaller wire size. Most models are factory preset to run at 115V.

NOTE: See pump label to verify voltage prewired at the factory. (Fig. 11)

11	HP:	1/2	PH	1	Hz	60
	Volts	115/230	S.F.	1.2	Amps	6.4/3.2
	S.F. Amps:	8.6/4.3	RPM	3450	Type	C
	Duty:	Cont.	Temp	65C	KVA Code	G
	Frame	56L	Ins Class	B		
	Factory prewired for 115V				Thermally protected automatic	
	Check voltage of power source				Use copper conductors only	

**ELECTRICAL HAZARD**

Improper installation may result in fire, explosion, electrical short or injury. Replace all covers before operating. Ground motor in accordance with local and national electrical codes. Disconnect power source before touching internal parts. Motors equipped with automatic protection may restart without warning. See instruction manual for proper installation procedure. Se reporter au manuel d'instructions pour suivre la procédure adéquate d'installation. Consulte el instructivo para conocer el procedimiento de instalación correcto.

12. For 230V service, change the following wires on the terminal board:

- Using a pair of needle nose pliers, pull the gray wire with the female flag connector from the "A" terminal spade post. Place it to the right on the "B" terminal space post. (Fig. 12a)

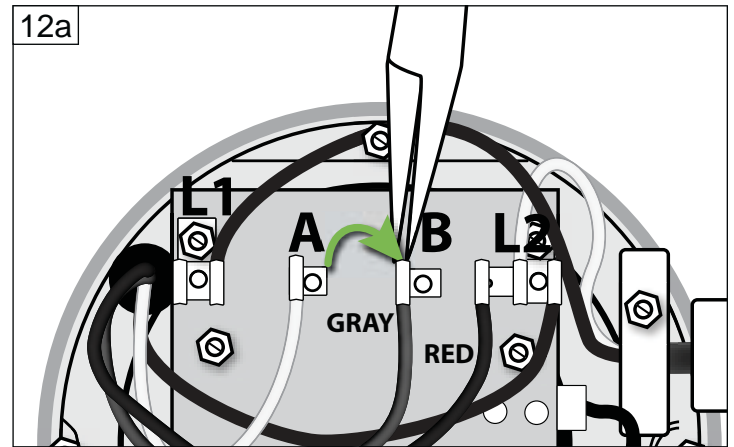

- Pull the red wire with the female flag connector from the "L2" terminal. Place it to the left on the "B" terminal space post. (Fig. 12b)

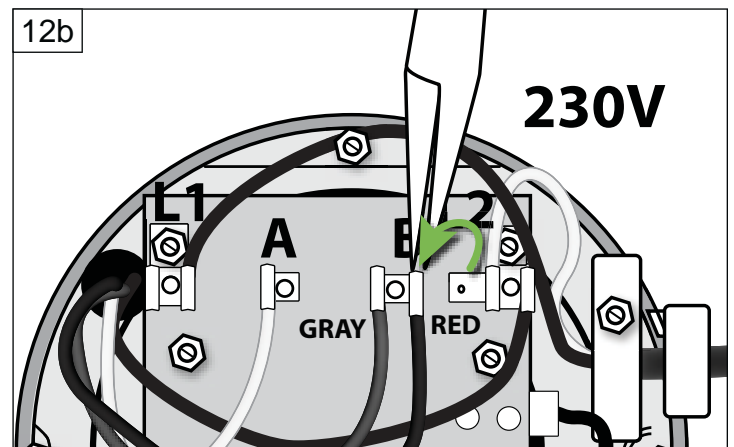

- Reinstall the rear motor cover. (Fig. 12)

NOTE: To change models from 230V to 115V, simply reverse instructions above.

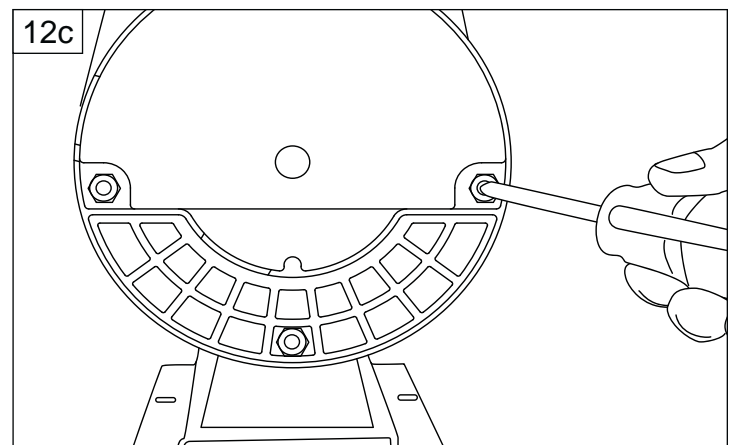

## PUMP PRIMING & STARTUP

### Shallow Well Application Only:

**⚠ CAUTION:** All pumps must be primed (filling the cavity with water) before they are first operated. This may take several gallons of water, as the suction line will be filled in addition to the pump cavity.

1. Remove the 1/2 in. priming plug with pressure gauge and air relief plug. (**Fig. 1**)

2. Slowly fill pump cavity until water comes out of air relief hole on top of the pump. (**Fig. 2**)

3. Replace air relief plug and continue adding water to pump cavity until water reaches the top of the priming plug. (**Fig. 3**)

4. Thread in priming plug and then open optional ball valve if installed by turning handle to line up with the pipe. (**Fig. 4**)

5. Turn on breaker to start pump

**⚠ IMPORTANT:** If the pump hums instead of pumping or turns off repeatedly, shut pump off immediately.

Check voltage. Make sure your incoming voltage matches the pump wiring voltage. See wiring guide in the instructions.

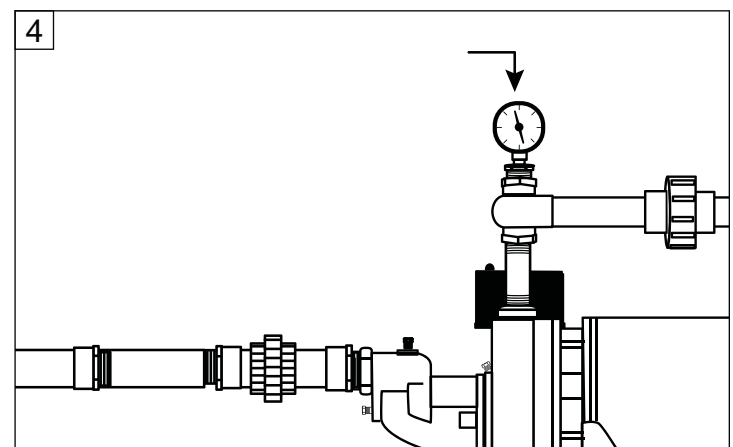
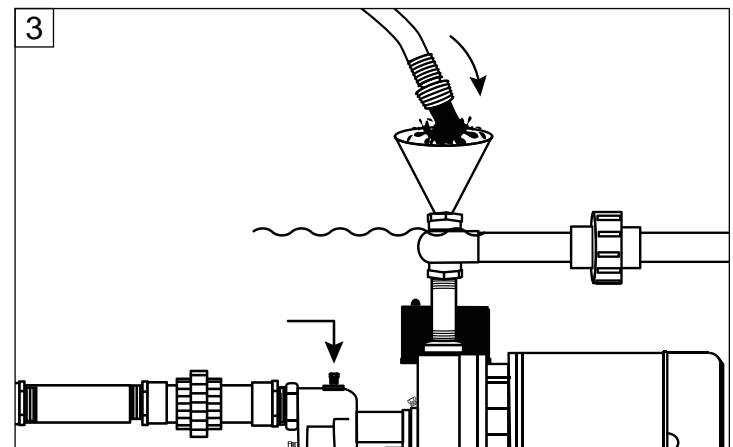
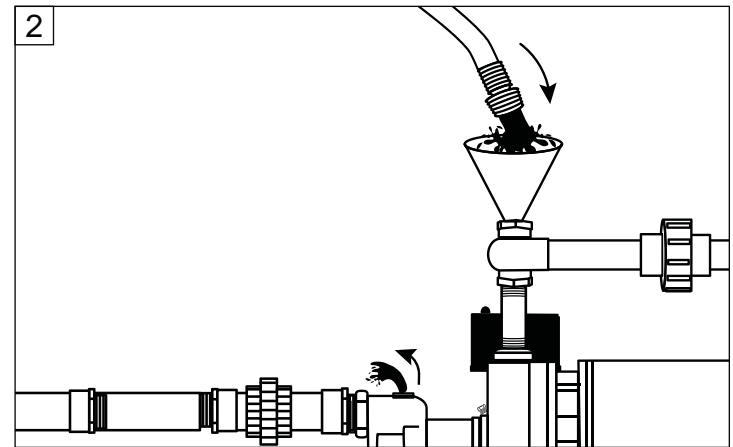
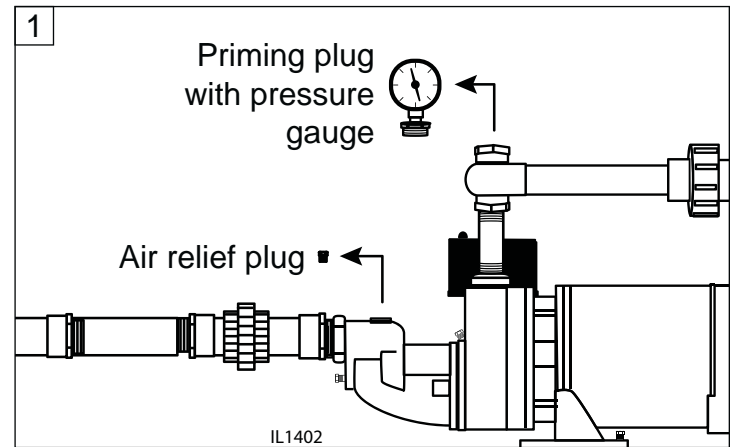

## PUMP PRIMING & STARTUP

### Deep Well Application Only:

**⚠ CAUTION:** All pumps must be primed (filling the cavity with water) before they are first operated. This may take several gallons of water, as the suction line will be filled in addition to the pump cavity.

1. Remove the 1/2" priming plug. (**Fig. 1**)

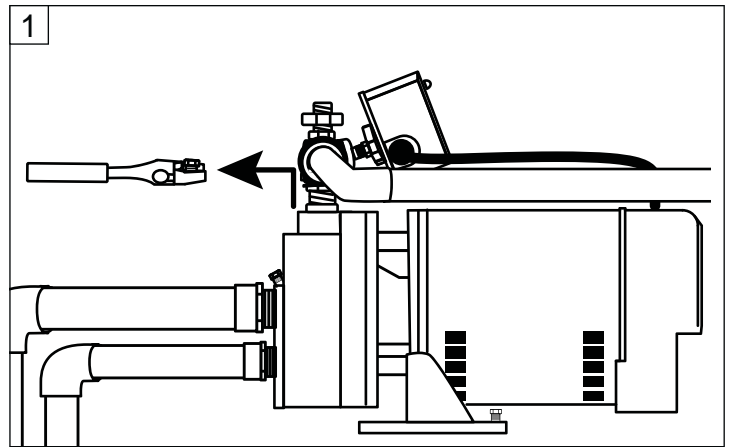

2. Fill pump cavity with water until full and replace priming plug. (**Fig. 2**)

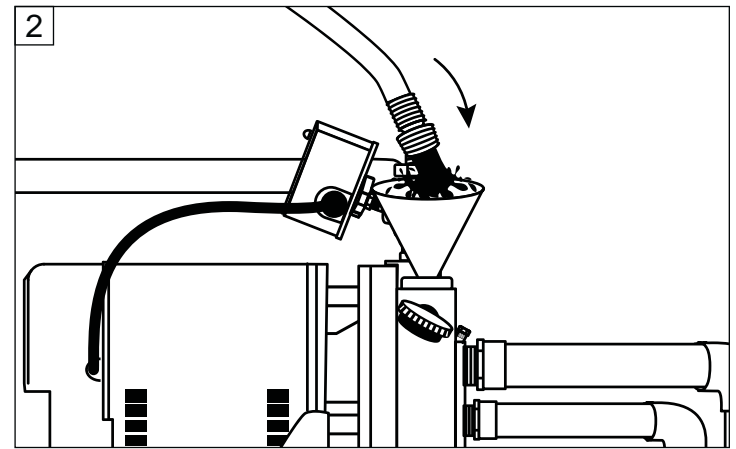

3. Tighten flow control screw completely by turning clockwise, then loosen two turns. Now start the pump. (**Fig. 3**)

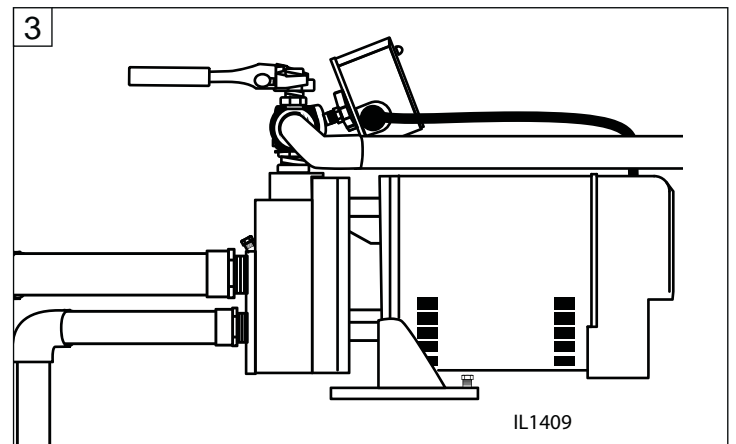

4. If pump is properly primed, pressure will quickly build and register on the gauge mounted directly on the pump body. If pressure does not build repeat priming operation. All air must be vented from the drive and suction pipes as well as the body before the pump will prime. The pump body may need to be filled several times in order to achieve the prime. (**Fig. 4**)

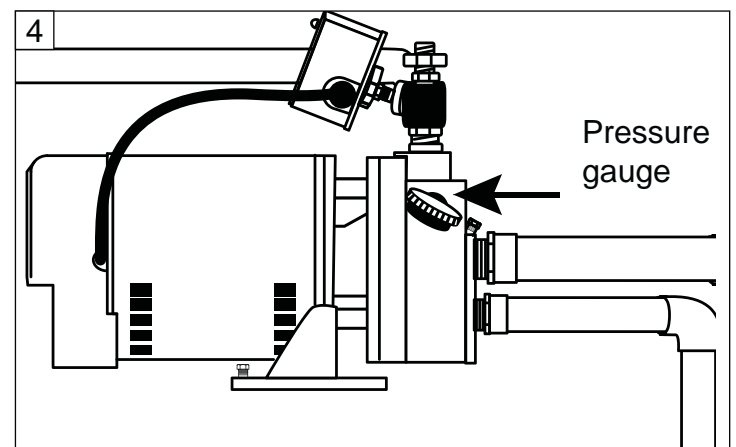

## PUMP PRIMING & STARTUP

5. With pump operating at high pressure, open two or more faucets and slowly unscrew the flow control screw until maximum flow is obtained. This steady pressure will be minimum operating pressure and should agree with the pressure shown below. The flow control screw diverts the proper amount of water to operate the ejector. (Fig. 5)

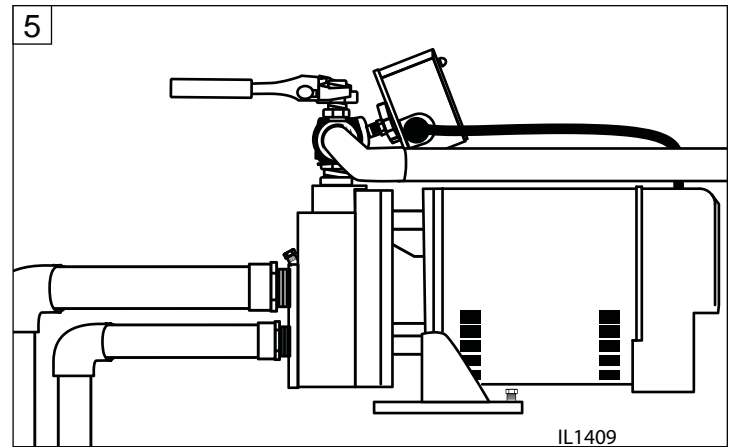

**AVERAGE OPERATING PRESSURE CHART 7**

HP	Pressure Setting
1/3	24 PSI
1/2	27 PSI
3/4	38 PSI
1	46 PSI
1-1/2	53 PSI

The correct control valve setting will depend on the type of well installation and pressure switch setting for the particular pump.

NOTE: Flow control is not required for shallow well applications.

- ⚠ IMPORTANT:** If the pump fails to prime within five minutes:  
Turn power off at the breaker box. Look for leaks or a milky color in the discharged water, which indicates an air leak. Re-prime if necessary, following steps 1 through 5 above. Reset breaker at the breaker box. All connections must be water and air tight in order for pump to operate.

## CARE AND MAINTENANCE

### MAINTENANCE

#### Lubrication

The pumps and motors require no lubrication. The ball bearings of the motor have been greased at the factory and under normal operating conditions should require no further greasing.

#### Freezing

1. Drain the entire system if there is danger of freezing. A drain plug is provided at the bottom of the pump case for this purpose. (Fig. 1)

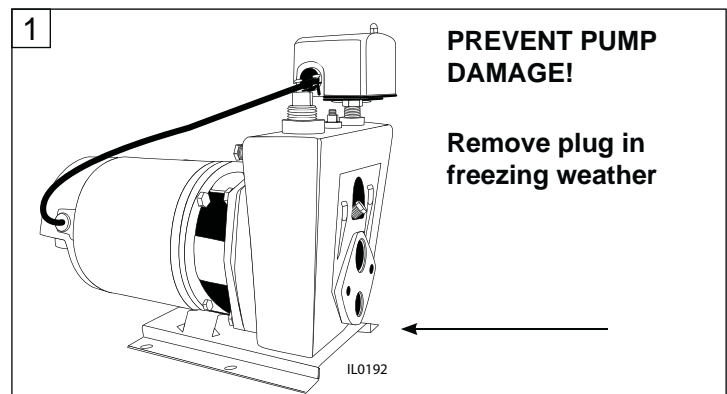

## CARE AND MAINTENANCE

---

### Rotary Seal Assembly Replacement

**CAUTION** *Make certain that the power supply is disconnected before attempting to service the unit! The rotary seal assembly must be handled carefully to avoid damaging the precision lapped faces of the sealing components.*

1. Disengage pump body from motor and mounting ring.
2. Remove diffuser and unthread impeller from the motor shaft. The motor shaft can be held by using a 9/16" open end wrench on the flats located in the middle of the mounting ring.
3. The rotary seal will come loose at this time. Use a screwdriver (or similar instrument) to pry the ceramic seal and rubber gasket from the recess of the mounting bracket.

**CAUTION** *Be careful not to damage the motor shaft or recess surface.*

4. Clean the recess and motor shaft thoroughly.
5. Install the new rotary seal assembly:
  - a. Insert the ceramic seal and the rubber gasket into the recess.

**NOTE:** To help facilitate installation, apply one drop of liquid soap solution to the outside diameter of the rubber gasket. Make certain that the ceramic seal is kept clean and free of dirt and/or oil.

Liquid Soap Solution: One drop of liquid soap combined with one teaspoon of water.

- b. Slip the remaining parts of the rotary seal assembly onto the motor shaft.

**NOTE:** Apply a light coating of liquid soap solution to the inside diameter of the rubber drive ring.

6. Replace the impeller and diffuser removed in Step 2.
7. Reassemble the pump body to the motor and mounting bracket.

### MOTOR REPLACEMENT

The motor can be replaced with any standard Nema 56J jet pump motor (of proper HP for each pump) by referring to the following instructions.

1. Follow steps as outlined under Rotary Seal Replacement and Pump Disassembly.
2. Remove cap screws that connect the motor to the mounting ring and pull motor away.
3. Replace motor with standard Nema 56J jet pump motor by positioning motor against the mounting frame and assembling with four (4) cap screws.

**Because damage to the shaft seal can occur in disassembly, a new seal will be necessary.**

4. Follow steps 4, 5, 6 & 7 of Rotary Seal Assembly to reassemble the remainder of the pump.

## TROUBLESHOOTING

<b>Problem</b>	<b>Possible Cause</b>	<b>Corrective Action</b>
Little or no discharge	1. Casing not initially filled with water	1. Fill pump casing
	2. Suction lift too high, or too long	2. Move pump closer to water source
	3. Hole or air leak in suction line	3. Repair or replace. Use pipe tape and pipe sealing compound
	4. Foot valve too small	4. Match foot valve to piping or install one size larger foot valve.
	5. Foot valve or suction line not submerged deep enough in water	5. Submerge lower in water
	6. Motor wired incorrectly	6. Check wiring diagram
	7. Casing gasket leaking	7. Replace
	8. Suction or discharge line valves closed	8. Open
Pump will not deliver water or develop pressure	1. No priming water in casing	1. Fill pump casing
	2. Leak in suction line	2. Repair or replace
	3. Discharge line is closed and priming air has nowhere to go	3. Open ball valve
	4. Suction line (or valve) is closed	4. Open
	5. Foot valve is leaking	5. Replace foot valve
	6. Suction screen clogged	6. Clean or replace
Loss of suction	1. Air leak in suction line	1. Repair or replace
	2. Suction lift too high	2. Lower suction lift, install foot valve and prime
	3. Insufficient inlet pressure or suction head	3. Increase inlet pressure by adding more water to tank or increasing back pressure
	4. Clogged foot valve or strainer	4. Unclog
Pump vibrates and/or makes excessive noise	1. Mounting plate or foundation not rigid enough	1. Reinforce
	2. Foreign material in pump	2. Disassemble pump and clean
	3. Impeller damaged	3. Replace
	4. Worn motor bearings	4. Replace
Pump will not start or run	1. Improperly wired	1. Check wiring diagram on motor
	2. Blown fuse or open circuit breaker	2. Replace fuse or close circuit breaker
	3. Loose or broken wiring	3. Tighten connections, replace broken wiring
	4. Stone or foreign object lodged in impeller	4. Disassemble pump and remove foreign object
	5. Motor shorted out	5. Replace
	6. Thermal overload has opened circuit	6. Allow unit to cool, restart after reason for overload has been determined



**CONVERTIBLE and SHALLOW WELL JET PUMP REPAIR PARTS**  
**"CPJ" and "CPJS" SERIES**  
**(For Pricing Refer To Repair Parts Price List)**

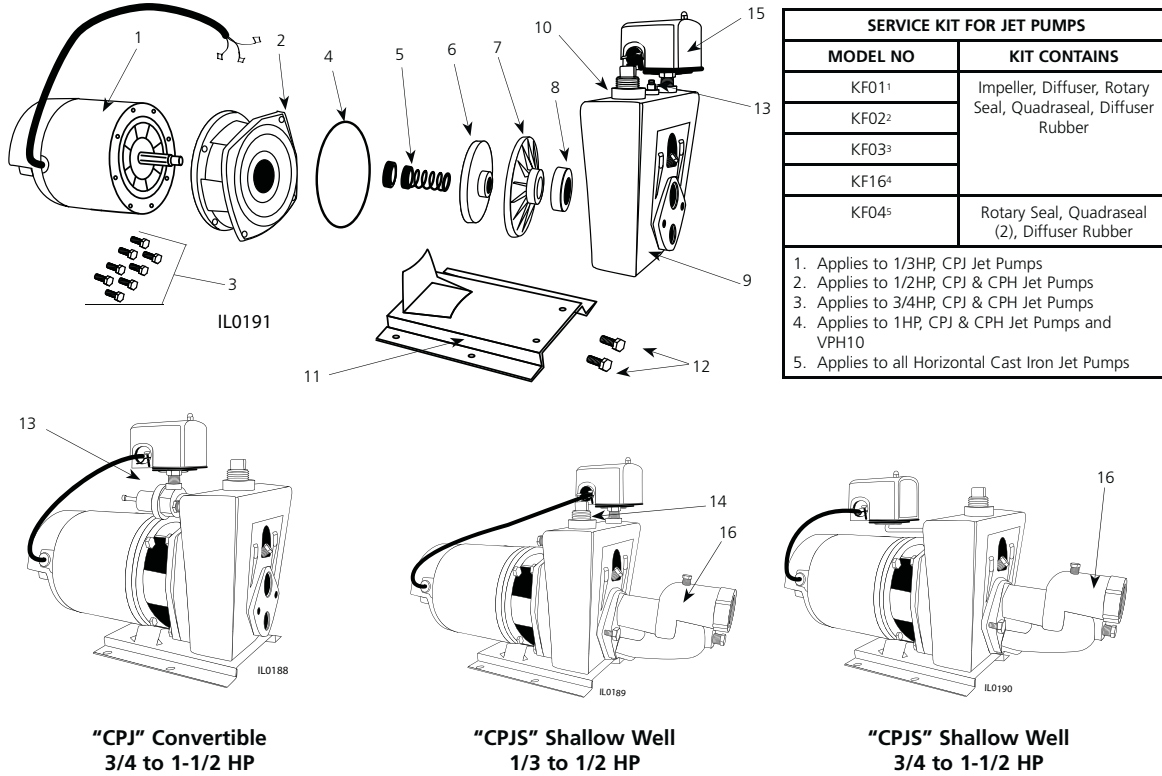

SERVICE KIT FOR JET PUMPS	
MODEL NO	KIT CONTAINS
KF01 <sup>1</sup>	Impeller, Diffuser, Rotary Seal, Quadraseal, Diffuser Rubber
KF02 <sup>2</sup>	
KF03 <sup>3</sup>	
KF16 <sup>4</sup>	
KF04 <sup>5</sup>	Rotary Seal, Quadraseal (2), Diffuser Rubber
1. Applies to 1/3HP, CPJ Jet Pumps 2. Applies to 1/2HP, CPJ & CPH Jet Pumps 3. Applies to 3/4HP, CPJ & CPH Jet Pumps 4. Applies to 1HP, CPJ & CPH Jet Pumps and VPH10 5. Applies to all Horizontal Cast Iron Jet Pumps	

ITEM	HORSEPOWER		1/3	1/2	3/4	1	1-1/2
	MODEL NO.: "CPJ" Convertible "CPJS" Shallow Well	PART NO.	CPJ03	CPJ05 CPJ05B	CPJ07 CPJ07B	CPJ10 CPJ10B	CPJ15
	DESCRIPTION		CPJ03S CPJ03SB	CPJ05S CPJ05SB	CPJ07S CPJ07SB	CPJ10S CPJ10SB	CPJ15S
1	Motor, Nema J (Thd) Motor Cover /Screws Screws, Cover Motor Lead Wire	021301R 021302	98J103 1 2 136135A	98J105 1 2 136135A	98J107 1 2 136135A	98J110 1 2 136135A	98J115 1 2 136136A
2	Mounting Ring	*	135314	135314	136137	136137	136137
3	Hex Hd. Cap Screws 3/8 x 3/4"		8	8	8	8	8
4	Ring, Square Cut		132583	132583	132429	132429	132429
5	Seal, Rotary w/Spring	131100	1	1	1	1	1
6	Impeller		139348††	139349††	134137	134138	132417
7	Diffuser		132424	132424	132425‡	132425‡	132464
8	Rubber, Diffuser	132428	1	1	1	1	1
9	Pump Body		132582	132582	132418	132418	132418
10	Plug, Priming	*	3/4" NPT	3/4" NPT	1" NPT	1" NPT	1" NPT
11	Base	132430A	1	1	1	1	1
12	Hex Hd. Cap Screws 3/8 x 1/2"	*	2	2	2	2	2
13	Control Valve "CPJ"		124330	124330	132446	132446	133383
14	Plug w/Gasket "CPJS"		128794	128794	-	-	-
15	Pressure Switch		132527	132527	132527	132527	132527
16	Shallow Well Ejector Package		SW03E-1626	SW05E-1630	SW07E-1432	SW10E-1334	SW15E-1238
†	Ejector Gasket Pkg. w/Bolts	132404	1	1	1	1	1
†	Ejector Gasket	130969	1	1	1	1	1

(\*) Standard Hardware Item  
 (†) Not Shown  
 (††) Impeller w/ 138138 Seal Ring  
 (‡) Diffuser w/ 134240 Insert