

D



JAY R. SMITH MFG. CO.
 DIVISION OF SMITH INDUSTRIES, INC.
 POST OFFICE BOX 3237
 MONTGOMERY, ALABAMA 36109-0237 (USA)
 TEL: 334-277-8520 FAX: 334-272-7396 www.jrsmith.com



LOCATION

SCUPPER DRAINS

FUNCTION: Used at junction of roof and parapet. Side outlet (90°) drains may be connected to outside downspout by using drain in conjunction with Fig. 1550 downspout adaptor. When connecting to an inside leader, the 45° outlet drains may be easily offset into the wall. The flush grate prevents obstruction to traffic. The angle grate prevents debris from blocking drainage.

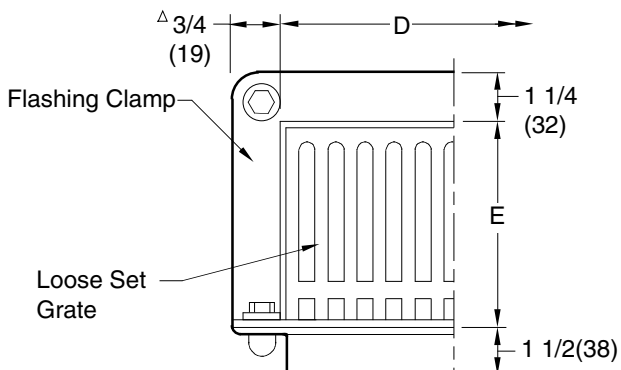
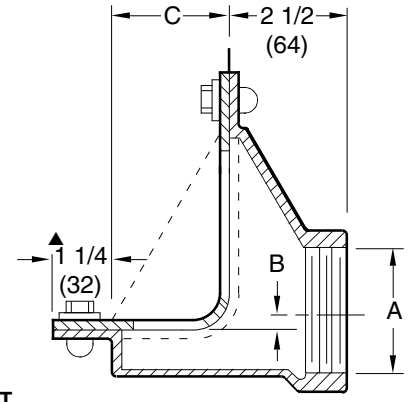

Fig. 1520 Shown



90° THREADED OUTLET
 Fig. 1510T ANGLE GRATE
 Fig. 1520T FLUSH GRATE

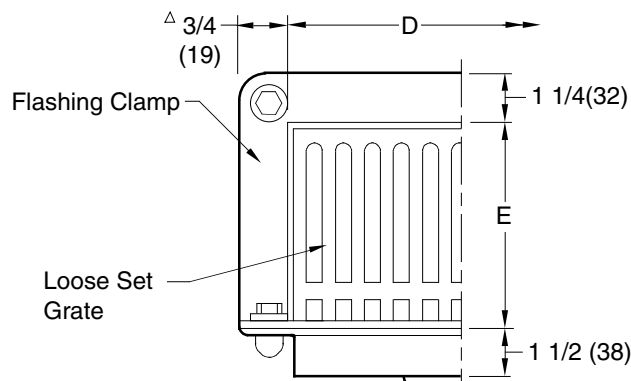
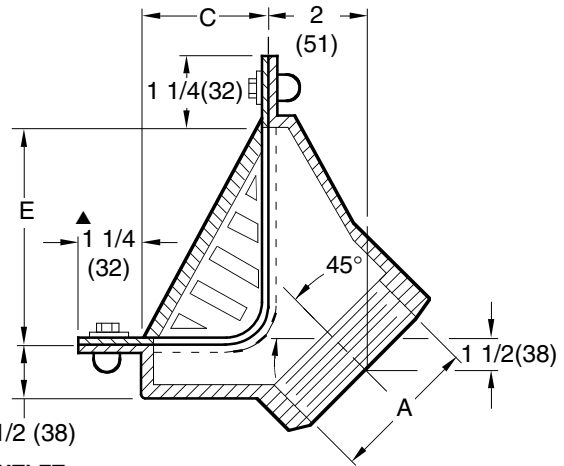

Fig. 1530 Shown



45° THREADED OUTLET
 Fig. 1530T ANGLE GRATE
 Fig. 1540T FLUSH GRATE

A SIZE	B	C	D	E	FREE AREA	
					ANGLE	FLUSH
02(50)	*				17.75	20
03(75)	1/4(6)	3 1/4 (83)	8 3/4 (220)	5 (125)	SQ IN (115)SQ CM	SQ IN (129) SQ CM
04(100)	1(25)					
05(125)	1 3/4(44)	4 1/4 (110)	10 1/2 (265)	6 1/2 (165)	35SQ IN (226)SQ CM	40 SQ IN (258) SQ CM
06(150)	1 3/4(44)	(110)	(265)	(165)		

* 02"(50) Size 1510/1520 "B" Dimension is 1/4"(6) Below Flange, Not Above as Shown.
 Δ For 05(125) & 06"(150) size add 1/2(13)".
 ▲ For 05(125) & 06"(150) size reduce by 3/16(5)".

REGULARLY FURNISHED:

Duco Cast Iron Body, Flashing Clamp and Loose Set Grate. Type of Outlet and Grate as indicated by Figure Number Selected.

VARIATIONS:

- Downspout Adaptor (Specify Fig. 1550)
- Secured Grate -SG
- Secured Grate with Vandal Proof Screws -U

OPTIONAL MATERIALS:

- Galvanized Cast Iron -G
- Nickel Bronze Face -NB
- Polished Bronze Face -PB
- Rough Bronze Face -RB
- Stainless Steel (Specify Fig. 9785)

NOTE: Dimensions shown in parentheses are in millimeters.

D	6-16-99	Revised Millimeters	CMD	BS	WEIGHT POUNDS	VOLUME CUBIC FEET	FIGURE NUMBER
C	7-1-96	Added Millimeters	CMD	BS			
B	6-4-93	Submittal Update	EMB	CR	1510, 1520, 1530, 1540		
A	6-18-86	Added Variation	PL	CR			
REV.	DATE	DESCRIPTION	BY	CKD.BY			

DRAWING NUMBER S1510

SIZE A

SCALE: NONE

DATE: 1-14-85

APPROVED BY: SB

CHECKED BY: SB

DRAWN BY: PL

1510, 1520, 1530, 1540

FIGURE NUMBER

DIMENSIONS ARE SUBJECT TO MANUFACTURERS TOLERANCE AND CHANGE WITHOUT NOTICE WE CAN ASSUME NO RESPONSIBILITY FOR USE OF SUPERSEDED OR VOID DATA