

AMERICAN Flow Control Submittal Information

4" - 12" SERIES 2500-1 RESILIENT WEDGE TAPPING VALVE , NRS

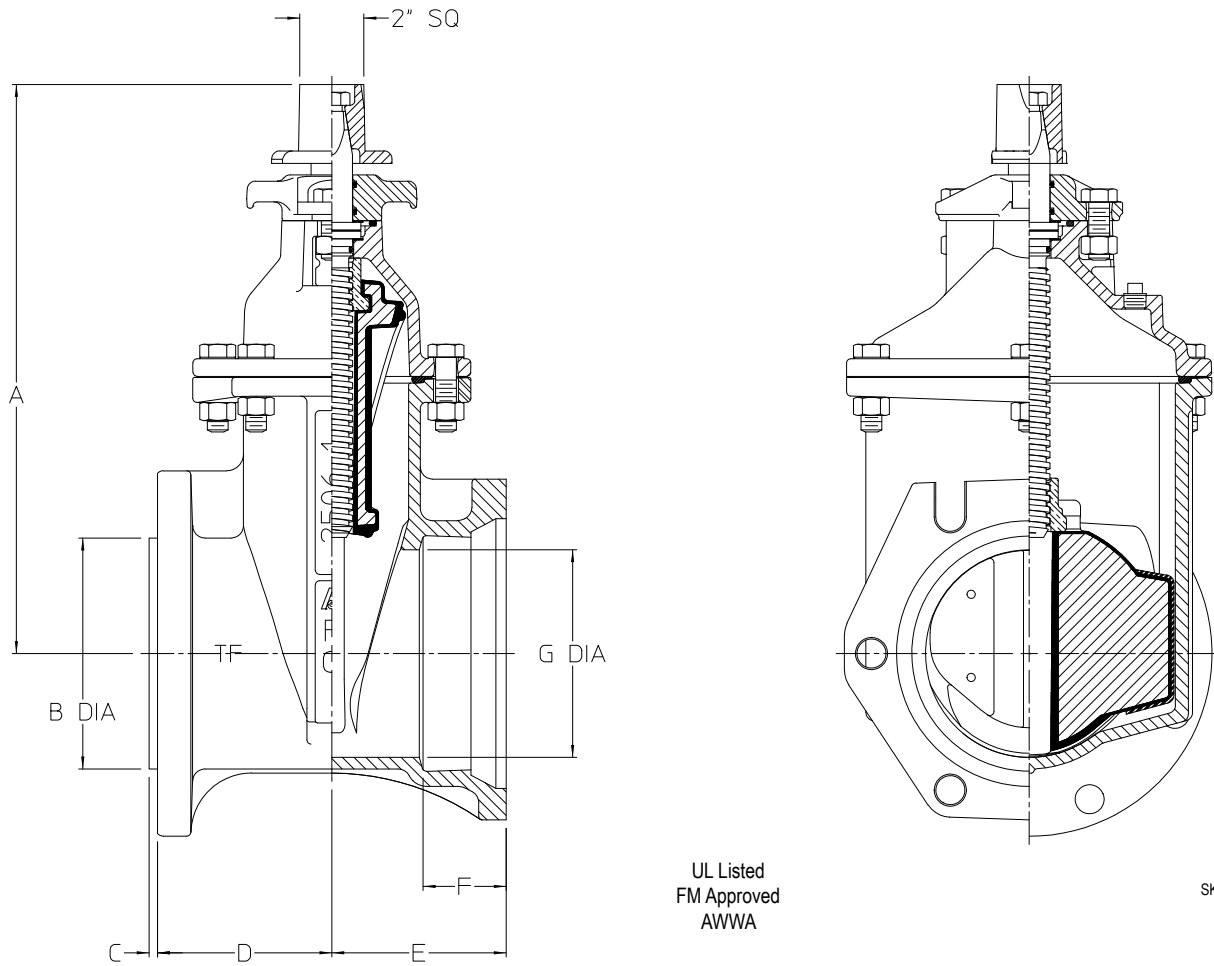

UL Listed
FM Approved
AWWA

SK20040504

DIMENSION	VALVE SIZE				
	4"	6"	8"	10"	12"
A	13.91	17.12	20.47	24.06	27.59
B +.000/-.031	4.984	6.984	8.984	10.984	12.984
C ± .016	.188	.250	.250	.250	.250
D (Flange End)	4.50	5.25	5.75	6.50	7.00
E (TM End)	5.00	5.25	6.62	7.12	7.38
F	2.50	2.50	2.50	2.50	2.50
G Waterway Dia.	4.25	6.25	8.25	10.25	12.25
No. of Turns to Open	14	20	26	32	38
Max Cutter Dia.	4.00	6.00	8.00	10.00	12.00



AMERICAN
FLOW CONTROL

THE RIGHT WAY

AMERICAN Flow Control
P.O. Box 2727
Birmingham, Al. 35202-2727
Phone: 1-800-326-8051
Fax: 1-800-610-3569
E-mail: afcsales@american-usa.com

Waterous Company
125 Hardman Avenue South
South St. Paul, Mn. 55075-1191
Phone: 1-888-266-3686
Fax: 1-800-601-2809
E-mail: afcsales@american-usa.com

WWW.AMERICAN-USA.COM

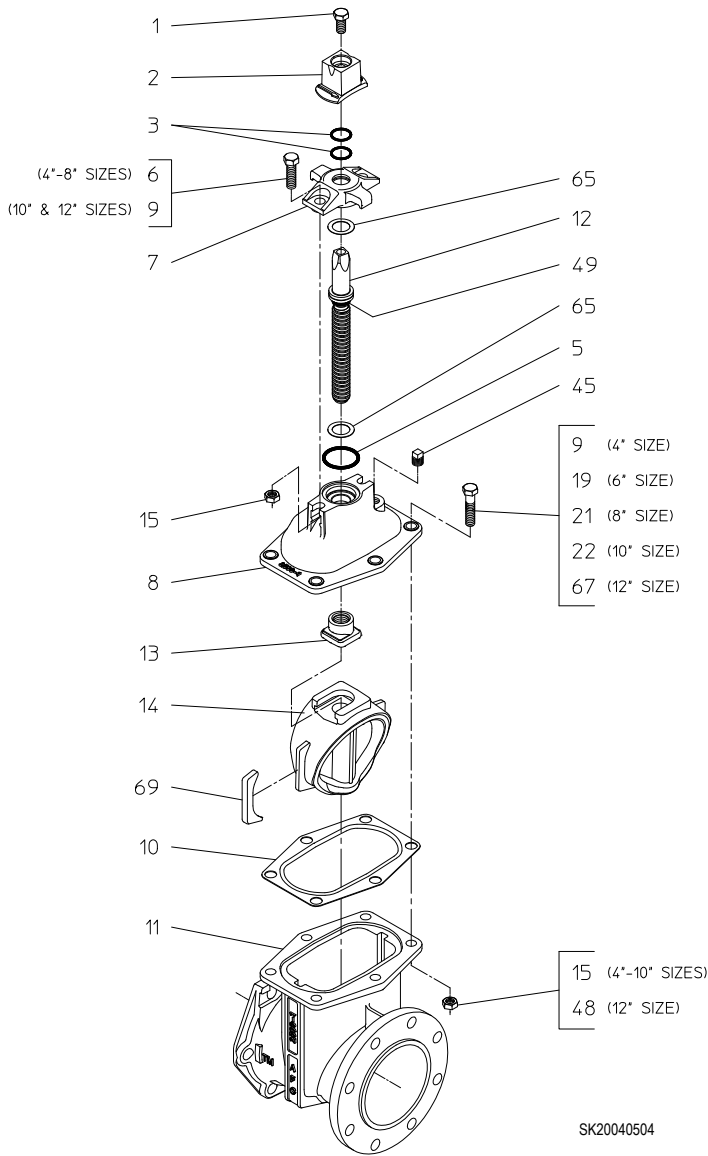

SK20040504

Construction shown is typical of the 6-inch size and is illustrative only. Construction of other sizes vary slightly. See elsewhere on this submittal for specific details.

NOTES:

1. Available in configurations that are UL Listed and FM Approved with 250 psig rated working pressure.
2. Meets requirements of ANSI/AWWA C515 with 250 psig rated working pressure.
3. Fusion-bonded epoxy-coated in accordance with ANSI/AWWA C550.
4. Certified to ANSI/NSF Standard 61.
5. Mechanical joint ends are in accordance with ANSI/AWWA C153/A21.53 and MSS SP-113.
6. Bolt pattern of flanged ends are in accordance with ANSI/AWWA C110/A21.10.
7. Raised pilot dimensions of flanged ends on tapping valves are in accordance with MSS SP-60.
8. Tapping valves are supplied with flanged-end hardware, including bolts, nuts, washers, ring-type gasket and flange protection kit. The flanged-end bolting is furnished in the same material as specified for the valve body bolting.

REF NO.	DESCRIPTION	MATERIAL
1	Hex Head Bolt, 5/8-11 x 1"	304 Stainless Steel
2	Operating Nut, 2" Square	Ductile Iron, ASTM A536
3	O-ring	Rubber
5	Stuffing Box Gasket	Rubber O-ring
6	Hex Head Bolt, 5/8-11 x 1-3/4"	304 Stainless Steel
7	Stuffing Box	Ductile Iron, ASTM A536
8	Bonnet	Ductile Iron, ASTM A536
9	Hex Head Bolt, 5/8-11 x 2"	304 Stainless Steel
10	Bonnet Gasket	Rubber
11	Body	Ductile Iron, ASTM A536
12	Stem	Manganese Bronze, ASTM B763, UNS C86700
13	Wedge Nut	Manganese Bronze, ASTM B763, UNS C86700
14	Resilient Wedge	EPDM Rubber Encapsulated Ductile Iron ASTM A536
15	Hex Nut, 5/8-11	304 Stainless Steel
19	Hex Head Bolt, 5/8-11 x 2-1/4"	304 Stainless Steel
21	Hex Head Bolt, 5/8-11 x 2-1/2"	304 Stainless Steel
22	Hex Head Bolt, 5/8-11 x 2-3/4"	304 Stainless Steel
45	Square Head Pipe Plug, 3/8 NPT	304 Stainless Steel
48	Hex Nut, 3/4-10	304 Stainless Steel
49	O-ring	Rubber
65	Thrust Washer	304 Stainless Steel
67	Hex Head Bolt, 3/4-10 x 3"	304 Stainless Steel
69	Wedge Cover	Acetal Polymer

OPTIONAL MATERIALS ARE AS FOLLOWS

BOLTS and NUTS: 316 Stainless Steel
 STEM: Cast NDZ-S Bronze, ASTM B763, UNS C99500
 STEM: Stainless Steel
 WEDGE NUT: Silicon Bronze, ASTM B584, UNS C87600

Open Direction: Left (C.C.W.) Right (C.W.)



AMERICAN
 FLOW CONTROL

THE RIGHT WAY

AMERICAN Flow Control
 P.O. Box 2727
 Birmingham, Al. 35202-2727
 Phone: 1-800-326-8051
 Fax: 1-800-610-3569
 E-mail: afcsales@american-usa.com

Waterous Company
 125 Hardman Avenue South
 South St. Paul, Mn. 55075-1191
 Phone: 1-888-266-3686
 Fax: 1-800-601-2809
 E-mail: afcsales@american-usa.com

WWW.AMERICAN-USA.COM