



YARWAY STEAM TRAPS

SERIES 711/721

Thermodynamic steam traps that provide consistent performance in less than perfect conditions.



711



721

FEATURES

- Repairable
- Easy to check cyclic operation
- Fail open design
- Self-draining (vertical mount)
- Energy efficient subcooled discharge
- Hardened stainless steel valve body and seat
- Single moving part
- Freeze proof
- Withstand superheat
- Unaffected by water hammer

GENERAL APPLICATION

The series 711/721 unibody plus disk trap is designed for light load applications such as steam tracing, drip and turbine drain. These traps are fully renewable in-line, energy efficient and easy to check.

TECHNICAL DATA

Technology:	Thermodynamic
Size:	3/8", 1/2", 3/4", 1" (DN 10, 15, 20, 25)
Maximum Temperature	
Rating:	750°F (400°C)
Operating Pressure:	Type 711/721 - 4 to 450 psig (0.3 to 31 bar) Type 711HP/721HP - 150 to 650 psig (10.3 to 45 bar)
Back pressure:	Up to 80% of inlet pressure, psia/bar
Capacity:	Up to 3500 lb/hr (1587.5 kg/hr)
Connections:	Threaded, Socket weld
Materials:	Low carbon (0.15% max.) chrome moly body and stainless steel trim

Applicable codes and standards

Pressure rating per ANSI/FCI-69-1.
Performance testing per ANSI/ASME PTC-39.1.
End connections per ANSI B1.20.1 for threaded ends, per ANSI B16.11 for socket-welding ends.

YARWAY STEAM TRAPS

SERIES 711/721

SERIES 711/721 DISK TRAP (THERMODYNAMIC)

The 711 is a simple straightway body. The 721 is a straightway body and has an integral wye strainer and blowoff valve. Both bodies accept the same renewal capsules without removing the bodies from the line. The standard capsule performs best when applied in service up to 450 psig / 31 bar. The HP capsule has been designed for 150 to 650 psig / 10.3 to 44.8 bar service to handle low load superheat service conditions.

HOW TO SPECIFY AND ORDER

Typical specification - trap shall be inline repairable thermodynamic disk trap. Specify end connections to be threaded or socket-welded. Trap shall have replaceable capsule. When specifying series 721, add "Trap shall have an integral strainer with stainless steel screen and integral blow-off valve."

HOW TO SIZE

1. Determine maximum temperature and pressure of application and verify with trap.
2. Determine operating conditions - Temperature, Inlet Pressure, Outlet Pressure, and Condensate Load (including factor of safety).
3. Determine the condensate load at the operating differential pressure is below what trap can handle.
4. Verify trap can handle back pressures including back pressure from installation.

CONDENSATE CAPACITY NEAR STEAM TEMPERATURE (for steam trap sizing)

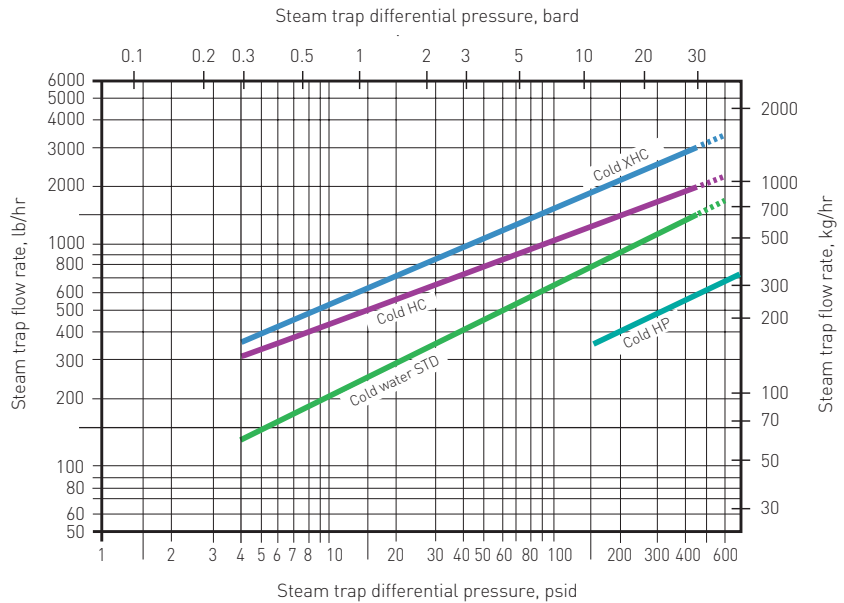
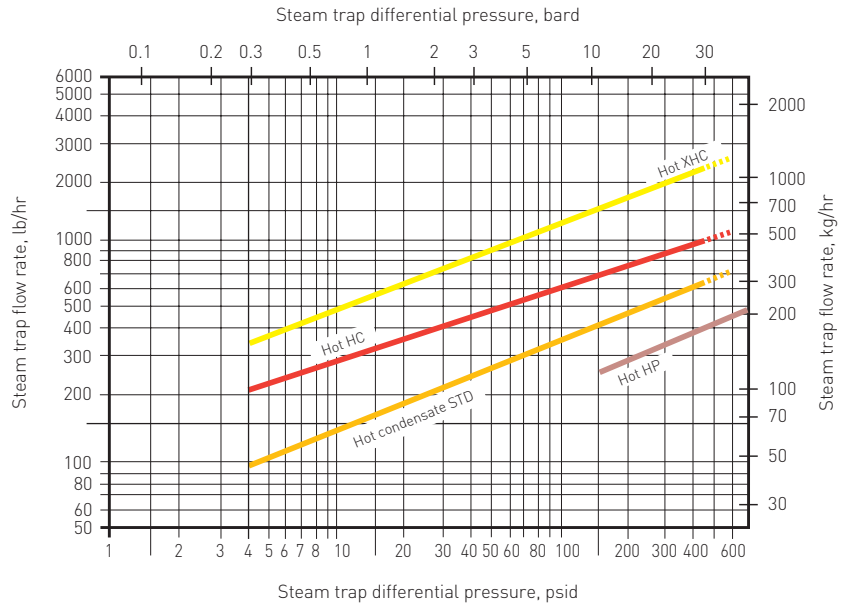

YARWAY STEAM TRAPS

SERIES 711/721

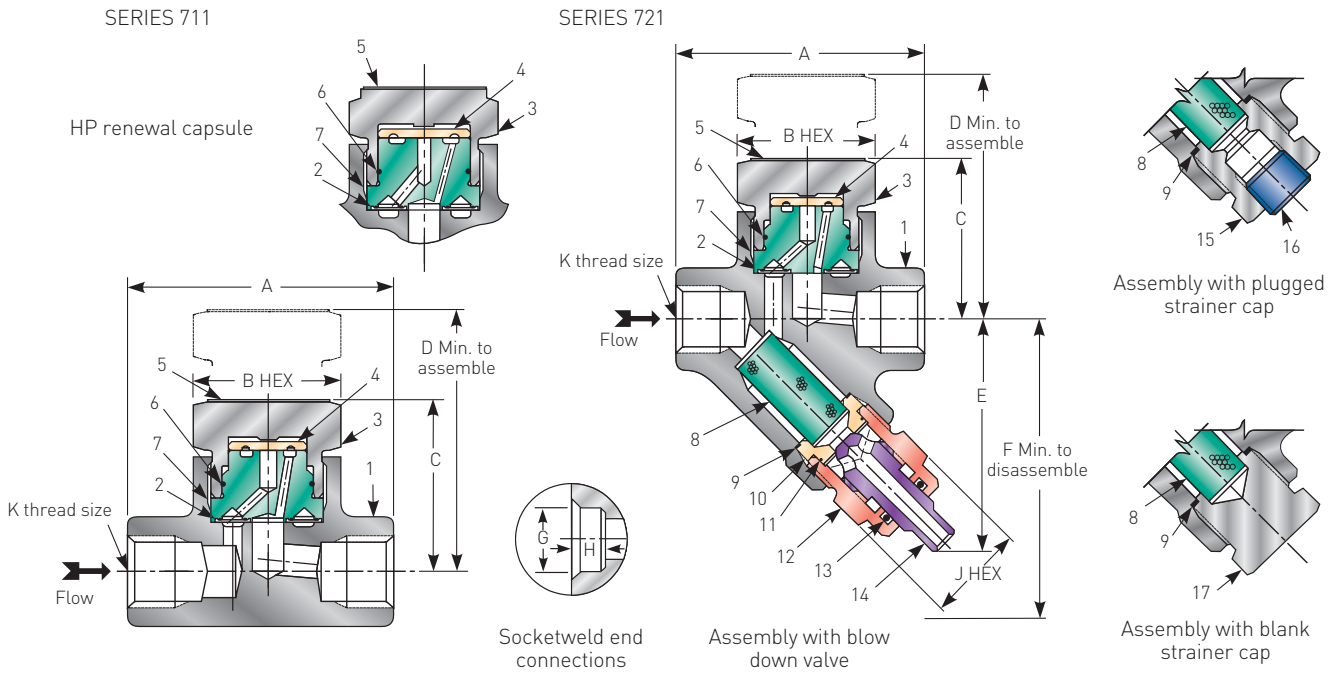

PARTS AND MATERIALS

Item	Part	Material
1	Body	Chrome moly
2 ^[1]	Seat gasket	Clad non-asbestos
3 ^[1]	Bonnet	Stainless steel
4 ^[1]	Disk	Stainless steel
5 ^[1]	Nameplate	Stainless steel
6 ^[1]	Retaining ring	Stainless steel
7 ^[1]	Seat	Stainless steel
8	Screen	Stainless steel
9 ^[2]	Cap gasket	Monel®
10 ^[2]	Blowdown seat	Stainless steel
11 ^[2]	Retaining ring	Stainless steel
12 ^[2]	Blowdown body	Stainless steel
13 ^[2]	O-ring	Silicone
14 ^[2]	Blowdown valve	Stainless steel
15 ^[3]	Strainer cap	Stainless steel
16 ^[3]	Plug 3/8 NPT	Carbon steel
17 ^[3]	Blank strainer cap	Stainless steel

NOTES

1. Part of factory assembled renewal capsule.
2. Factory assembled blowdown valve renewal kit.
3. Optional strainer caps.

DIMENSIONS AND WEIGHTS

Trap size in. (DN)	Nominal dimensions, in. (mm)										Weight lb. (kg)	
	A	B	C	D	E	F	G	H	J	K	Series 711	Series 721
3/8 [10]	3 5/32 [80]	1 1/2 [38]	1 15/16 [49]	2 11/16 [68]	2 7/8 [73]	3 15/16 [100]	0.695 [17.6]	3/8 [9.5]	1 1/16 [27]	3/8 NPT	1 1/2 [0.7]	2 1/4 [1.1]
1/2 [15]	3 5/32 [80]	1 1/2 [38]	1 15/16 [49]	2 11/16 [68]	2 7/8 [73]	3 15/16 [100]	0.860 [21.8]	3/8 [9.5]	1 1/16 [27]	1/2 NPT	1 1/2 [0.7]	2 1/4 [1.1]
3/4 [20]	3 35/64 [90]	1 1/2 [38]	1 15/16 [49]	2 11/16 [68]	3 1/4 [83]	4 5/16 [110]	1.070 [27.2]	1/2 [12.7]	1 3/16 [30]	3/4 NPT	2 [0.9]	2 3/4 [1.3]
1 [25]	3 15/16 [100]	1 1/2 [38]	1 15/16 [49]	2 11/16 [68]	3 3/8 [86]	4 7/16 [113]	1.335 [33.9]	1/2 [12.7]	1 3/16 [30]	1 NPT	2 1/4 [1.1]	3 1/2 [1.6]

VCTDS-15417 © 2020 Emerson Electric Co. All rights reserved 11/20. Yarway is a mark owned by one of the companies in the Emerson Automation Solutions business unit of Emerson Electric Co. The Emerson logo is a trademark and service mark of Emerson Electric Co. All other marks are the property of their prospective owners.

The contents of this publication are presented for informational purposes only, and while every effort has been made to ensure their accuracy, they are not to be construed as warranties or guarantees, express or implied, regarding the products or services described herein or their use or applicability. All sales are governed by our terms and conditions, which are available upon request. We reserve the right to modify or improve the designs or specifications of such products at any time without notice.

Emerson Electric Co. does not assume responsibility for the selection, use or maintenance of any product. Responsibility for proper selection, use and maintenance of any Emerson Electric Co. product remains solely with the purchaser.

Emerson.com