

MSS SP-80 GATE VALVES

UNION BONNET, THREADED ENDS
 1/4" - 3" (6 - 70mm) CLASSES 200 & 300
 BRONZE RISING STEM

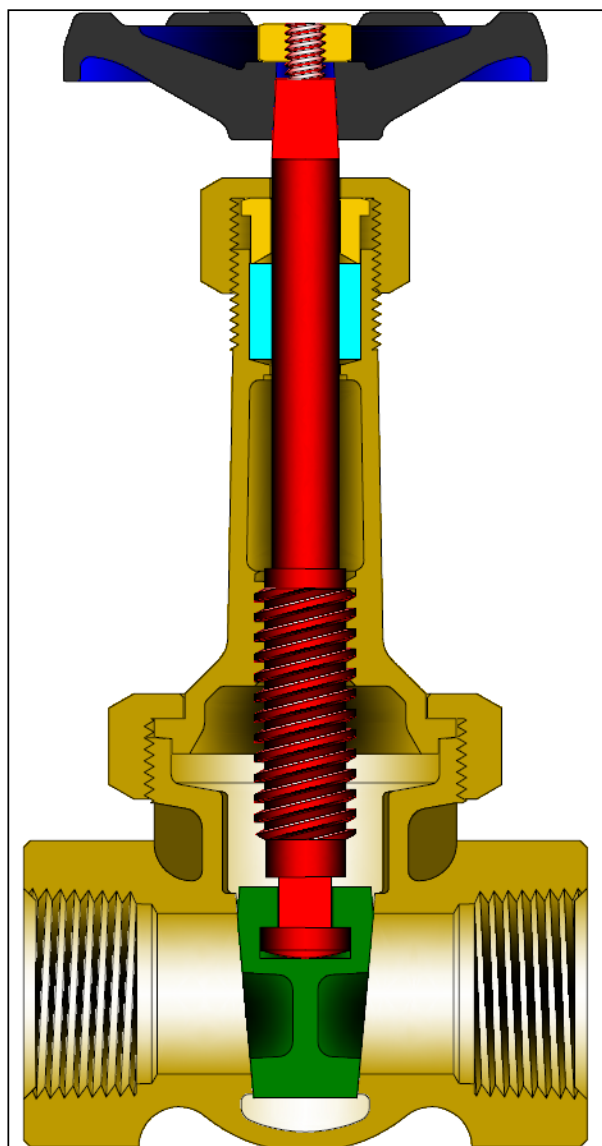

Class	Fig. No.
200	375
300	377

STANDARD MATERIALS

PART	MATERIALS
Body	B61
Bonnet	B61
Bonnet Ring	B61
Wedge	B61
Stem	B371 C69400
Packing Nut	B62 or B16
Gland	B16
Packing	Graphite
Hand Wheel	A47 Gr. 32510
Hand Wheel Nut	Brass
Wheel Plate	Aluminum

Design Specifications

Item	Applicable Specification
Pressure - temperature ratings	MSS SP-80
General valve design	MSS SP-80
Thread design	ASME B1.20.1
Materials	ASTM

DESIGN FEATURES:

- Renewable solid wedges.
- Integral seats.
- High-Tensile bronze alloy stem.
- Stems are rotating / rising design.
- Each valve is shell and seat pressure tested per industry standard MSS SP-80.

GATE VALVE DIMENSIONS (CLASSES 200 & 300)

SIZE	FIG 375							FIG 377						
	A	C	D	E	WT	lb kg	CV	A	C	D	E	WT	lb kg	CV
¼	1.81	4.3	0.25	2.1	0.8		3.2	1.94	4.9	0.25	3.0	1.3		3.2
6	46	108	6	54	0.4			49	124	6	76	0.6		
3/8	2.06	4.3	0.38	2.1	0.9		7.1	2.13	4.9	0.38	3.0	1.3		7.1
10	52	108	10	54	0.4			54	124	10	76	0.6		
½	2.44	4.9	0.50	2.5	1.2		12.6	2.44	5.9	0.50	3.3	1.8		12.6
13	62	124	13	64	0.7			62	149	13	83	0.8		
¾	2.56	6.1	0.75	2.8	2.0		30	2.69	7.2	0.75	3.6	3.0		30
20	65	156	19	70	0.9			68	183	19	92	1.3		
1	2.94	7.4	1.00	3.0	2.7		55	3.00	8.3	1.00	4.1	4.9		55
25	75	187	25	76	1.2			76	210	25	105	2.2		
1¼	3.13	8.6	1.25	3.3	4.7		90	3.38	9.5	1.25	4.6	6.9		90
32	79	219	32	83	2.1			86	241	32	117	3.1		
1½	3.50	9.6	1.50	3.6	5.5		130	3.75	10.8	1.50	5.1	8.9		130
40	89	244	38	92	2.5			95	273	38	130	4.0		
2	4.00	11.7	2.00	4.1	9.1		240	4.38	13.1	2.00	5.7	17		240
50	102	297	51	103	4.1			111	333	51	144	7.7		

